

| F.A.P. RTE. | SECTION | COUNTY | TOTAL SHEETS | SHEET NO. |
|--|---------|---------------------------|--------------|-----------|
| * | ** | BROWN | 10 | 9 |
| STA. | | TO STA. | | |
| FED. ROAD DIST. NO. | | ILLINOIS FED. AID PROJECT | | |
| • LA GRANGE WETLAND BANK • D-6 WETLAND MITIGATION NO. 2 | | | | |

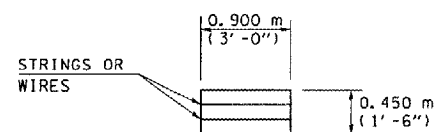

HAY OR STRAW BALE
(TYPICAL ELEVATION)

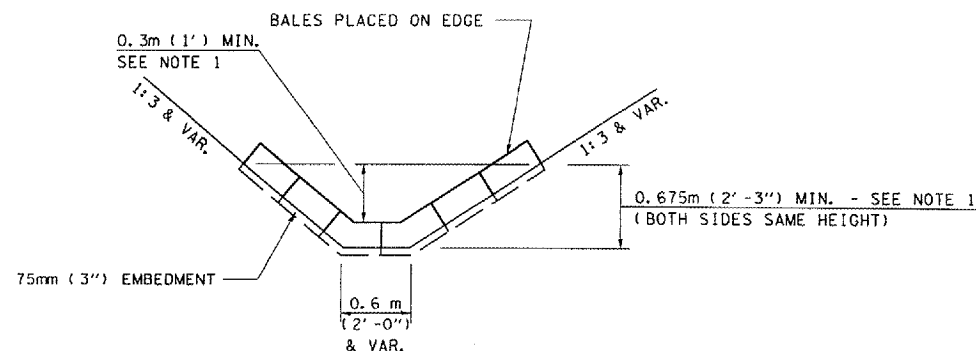

HAY OR STRAW BALE TEMPORARY DITCH CHECK
(TYPICAL & SEE GENERAL NOTES FOR SUBSTITUTION TO FLUSH RIPRAP DITCH CHECK)

LEGEND FOR STORM WATER POLLUTION PREVENTION PLAN

| ITEM | SYMBOL |
|---|------------|
| AGGREGATE (EROSION CONTROL) (STONE DUMPED RIPRAP DITCH CHECKS: Height = 0.6m (2')) | |
| TEMPORARY DITCH CHECKS (HAY OR STRAW BALE DITCH CHECKS OR APPROVED SUBSTITUTION) | |
| INLET PIPE PROTECTION (I&PP) (HAY OR STRAW BALE DITCH CHECKS OR APPROVED SUBSTITUTION) | |
| EROSION CONTROL FENCE | |
| EARTH EXCAVATION FOR EROSION CONTROL (SEDIMENT BASINS) | |
| PRESERVE EXISTING TREES, WOODLANDS, AND UNDERSTORY (OUTSIDE CONSTRUCTION LIMITS) | |
| ITEM PLACED AT BEGINNING OF CONSTRUCTION (Requirement) | * [ITEM] * |
| ITEM PLACED AS DIRECTED BY ENGINEER (When required by situation) | [ITEM] |
| DIRECTION OF OVERLAND FLOW | |

GENERAL NOTES:
 All items shall be constructed as shown on this sheet, on Standard 280001, and as directed by the Engineer.
 The symbology on the STORM WATER POLLUTION PREVENTION PLAN sheets does not represent the size or quantity of bales, for number of bales refer to details and notes shown on this sheet and/or as directed by the Engineer.

THE CONTRACTOR SHALL INSTALL DITCH CHECKS AS DIRECTED BY THE ENGINEER. IF THE ENGINEER ELECTS TO UTILIZE FLUSH RIPRAP DITCH CHECKS IN LIEU OF TEMPORARY DITCH CHECKS AS SHOWN ON THE FOLLOWING PLAN SHEETS, THE SPACING SHOULD BE DOUBLED.

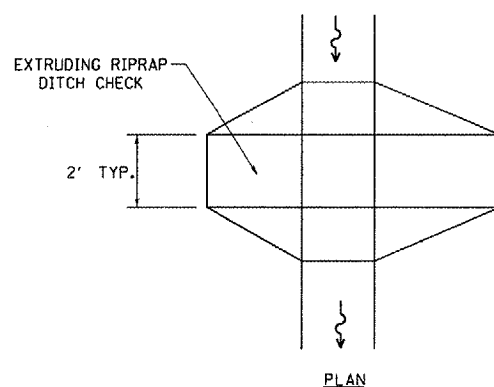

PLAN

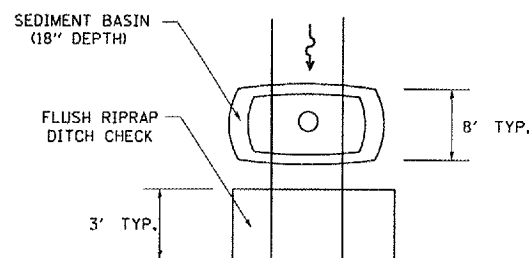

PLAN

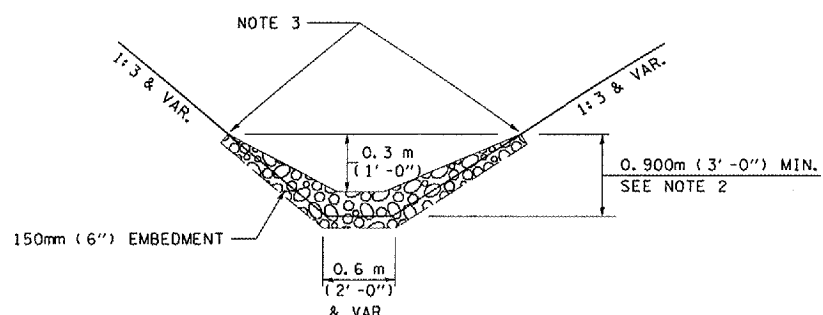

OPTION 1
(EXTRUDING DITCH CHECK)
RECOMMENDED FOR AREAS W/ RIPRAP DITCH LINING

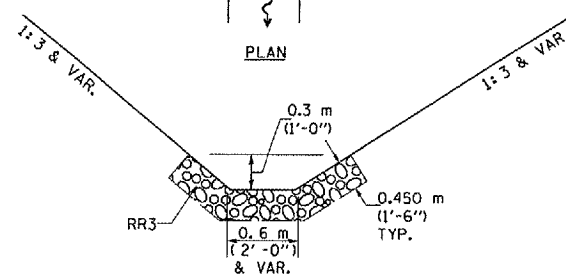

OPTION 2
(FLUSH DITCH CHECK)
RECOMMENDED FOR AREAS W/O RIPRAP DITCH LINING

STONE DUMPED RIPRAP DITCH CHECK
(TYPICAL & OPTIONS 1 & 2 AS DIRECTED BY THE ENGINEER)

NOTE 1: BALES SHALL EXTEND FAR ENOUGH UP THE SLOPES TO ALLOW 0.3m (1') OVERTOPPING TO AVOID ERODING AROUND THE EDGES OF THE BALES.

NOTE 2: RIPRAP SHALL EXTEND FAR ENOUGH UP THE SLOPES TO ALLOW 0.3m (1') OVERTOPPING TO AVOID ERODING AROUND THE EDGES OF THE RIPRAP.

NOTE 3: ENDS SHALL BE TIED INTO SLOPES.

| REVISIONS | |
|------------|---------|
| NAME | DATE |
| CAD Symbol | AUG99 |
| JCN | MAR2004 |
| | |
| | |
| | |
| | |
| | |
| | |
| | |

ILLINOIS DEPARTMENT OF TRANSPORTATION
STORM WATER POLLUTION PREVENTION PLAN

SCALE: VERT. HORIZ.
 DATE: APRIL 5, 1999
 DRAWN BY CADD
 CHECKED BY JCN

SWPPLAN