

STATE OF ILLINOIS
DEPARTMENT OF TRANSPORTATION

INDEX OF SHEETS

1. General Plan and Elevation
2. Stage Construction Details
3. Temporary Concrete Barrier
4. Superstructure Removal
5. Concrete Deck Beam Repairs
6. Deck Plan and Cross Section
7. Superstructure Details
8. Deck Joints
9. Pedestrian Railing
10. Framing Plan
11. Box Beam Details
12. Abutment Removal and Repair
13. Abutments
14. Bar Splicer Assembly Details

ROUTE NO.	SECTION	COUNTY	SHEETS	SHEET NO. 1
FAP 305	*	Cook	72 59	14 SHEETS
FED. ROAD DIST. NO. 7	ILLINOIS	FED. AID PROJECT-		

Contract No. 62853 *2004-108 BR
GENERAL NOTES

1. Reinforcement bars shall conform to the requirements of AASHTO M-31 or M-322 Grade 60.
2. Plan dimensions and details relative to existing structure have been taken from existing plans and are subject to nominal construction variations. It shall be the Contractor's responsibility to verify such dimensions and details in the field and make necessary approved adjustments prior to construction or ordering of materials. Such variations shall not be cause for additional compensation for a change in the scope of the work, however, the Contractor will be paid for the quantity actually furnished at the unit price bid for the work.
3. Any reinforcement bars that are damaged during concrete removal shall be replaced with an approved bar splice or anchorage system. Cost included with "Concrete Removal".
4. Protective Coat shall be applied to the entire top surface of the bridge deck including sidewalk and the tops and inside vertical faces of the sidewalk parapets and as directed by the Engineer.
5. The Contractor must follow the guidelines of Article 107.09 while performing removal operations.
6. Expansion guards which are not cast in the precast unit shall be fabricated and erected according to Article 503.10(c) of the Standard Specifications and are included in quantity of structural steel.
7. The top surface of the beams shall be finished according to Article 504.06 of the Standard Specification except that the surface shall not be roughened by brooming. The finished surface shall be free of depressions or high spots with sharp corners, and the top edge of keys shall be rounded or chamfered a minimum of 1/4".

TOTAL BILL OF MATERIAL

ITEM	UNIT	QUANTITY
Bituminous Concrete Surface Removal Complete	Sq Yd	367
Concrete Removal	Cu Yd	11.0
Preformed Joint Seal 1 3/4"	Foot	70
Preformed Joint Seal 2 1/2"	Foot	70
Concrete Superstructure	Cu Yd	72.1
Bridge Deck Grooving	Sq Yd	433
Protective Coat	Sq Yd	573
Formed Concrete Repair (Depth Equal to or Less Than 5")	Sq Ft	500
Reinforcement Bars, Epoxy Coated	Pound	12,520
Pedestrian Railing	Foot	135
Epoxy Crack Sealing	Foot	110
Concrete Wearing Surface	Sq Yd	433
Keyway Repair	Foot	14
Bar Splicers	Each	148
Furnishing and Erecting Structural Steel	Pound	2,150
Bearing Pad Adjustment	Each	32
Removal of Existing Precast Prestressed Concrete Deck Beams	Sq Ft	1,210
Precast Prestressed Concrete Deck Beams (33" Depth)	Sq Ft	1,210
Formed Concrete Repair (Depth Greater Than 5")	Sq. Ft.	150

Benchmark: Chiseled Square in N.E. corner of the North Abutment of the Wolf Rd. Bridge over Palatine Rd. Station 950+34 offset 36'-5" right, Elevation = 649.60
Existing Structure: Structure No. 016-0680 built as Wolf Road, over Palatine Road, Section 110-1415 in 1963 by the Cook County Highway Department. The length of the structure is 66'-2" center to center of bearings. The superstructure consists of 33"x36" PPC Deck Beams supporting a bituminous concrete wearing surface. The existing deck is 70'-0" out to out of deck.

Scope of Work:

1. Remove bituminous concrete wearing surface and waterproofing membrane system.
2. Remove and replace six Deck Beams, Sidewalks and Concrete pedestrian rail.
3. Repair the remaining concrete Deck Beams.
4. Reconstruct the expansion joints and place new concrete wearing surface - variable depth.
5. Repair the existing abutments.
6. Resurface the existing approach slabs.
(See Roadway Plans)

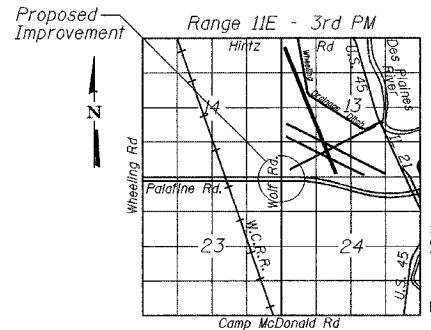

LOCATION SKETCH

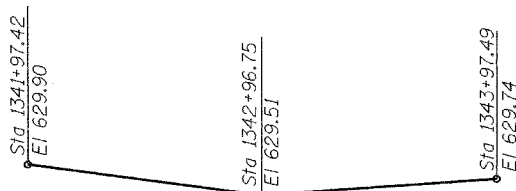

PROFILE GRADE PALATINE RD

(PGL Along North Median Edge of Pavement)

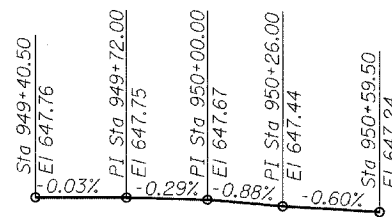

PROFILE GRADE WOLF RD

(Along Centerline Roadway)

DESIGN SPECIFICATIONS

2002 AASHTO

DESIGN STRESSES

FIELD UNITS

$f_y = 60,000$ psi (Reinf.)
 $f'_c = 3,500$ psi

PRECAST PRESTRESSED UNITS

$f'_c = 5,000$ psi
 $f'_{ci} = 4,000$ psi
 $f'_s = 270,000$ psi (1/2" ϕ Low Relaxation Strands)
 $f'_{si} = 201,960$ psi (1/2" ϕ Low Relaxation Strands)

DESIGNED	BPS
CHECKED	KFA
DRAWN	BPS
CHECKED	GSP

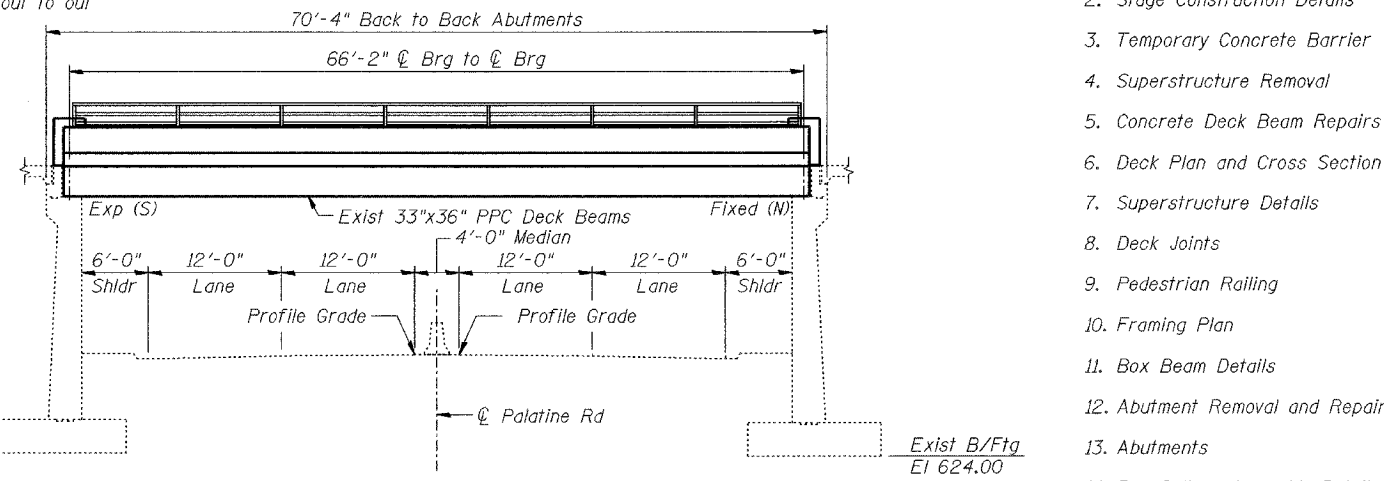

ELEVATION (Looking West)

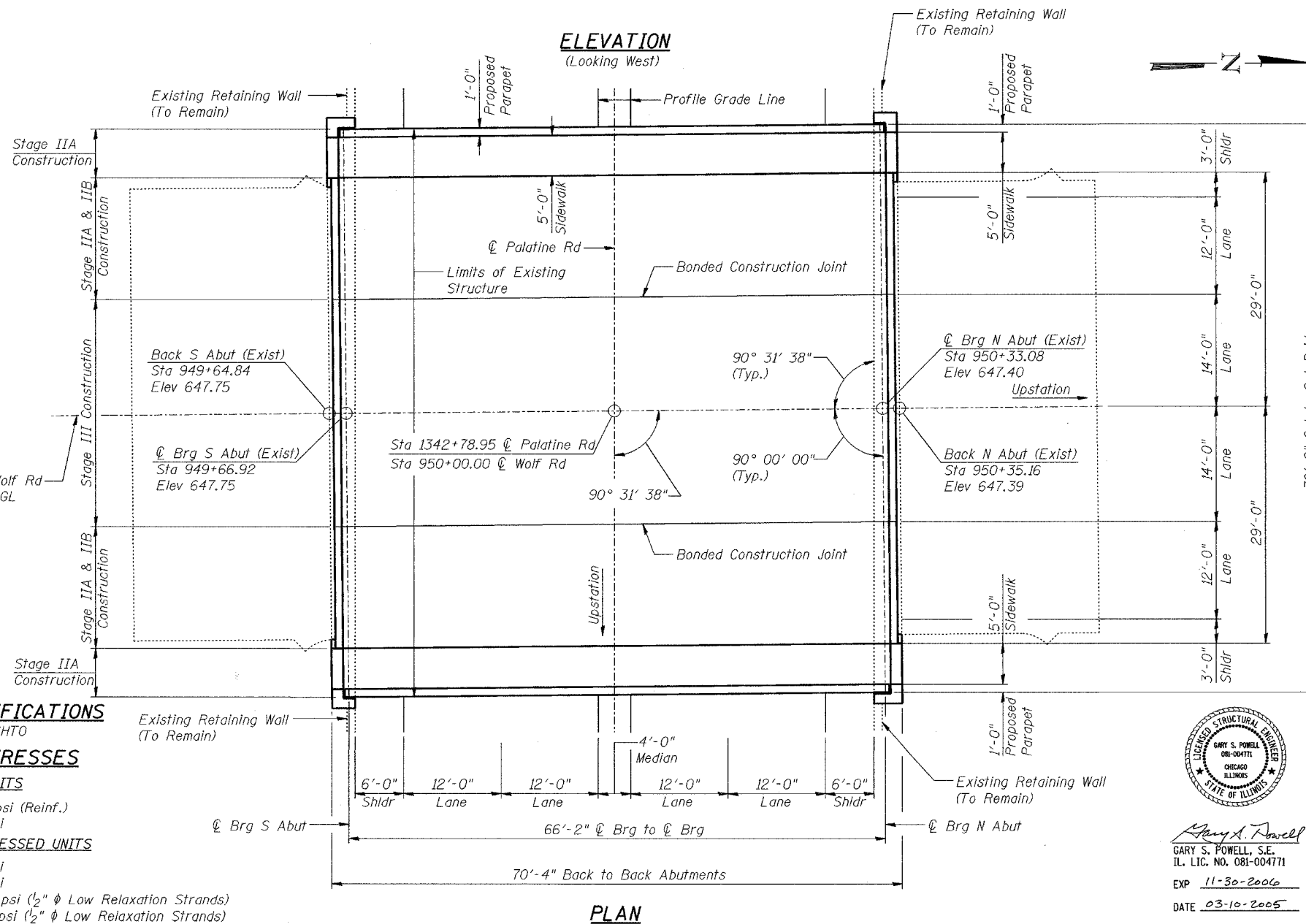

PLAN



GARY S. POWELL, S.E.
IL. LIC. NO. 081-004771
EXP 11-30-2006
DATE 03-10-2005

GENERAL PLAN AND ELEVATION
WOLF RD. OVER PALATINE RD.
F.A.P. RTE. 305 SECT. 2004-108 BR
COOK COUNTY
STATION 950+00.00
STRUCTURE NO. 016-0680