



HANSON PROFESSIONAL SERVICES INC.

815 Commerce Drive, Suite 200
Oak Brook, Illinois 60523
Telephone: 630.990.3800
Fax: 630.990.3801



3580 North McAree Road
Waukegan, Illinois 60087
Phone: 847.244.0055
Fax: 847.244.3813

REPAIR SELECTED PAVEMENT AREAS, REHABILITATE HANGAR TAXILANES AND SERVICE ROAD, AND CONSTRUCT NEW HANGAR PAVEMENTS

A.I.P. PROJ.: 3-17-0105-B30
IL. PROJ.: UGN-3449

LEGEND

- ① EXISTING BITUMINOUS PAVEMENT
- ② EXISTING BITUMINOUS AGGREGATE BASE COURSE
- ③ BITUMINOUS PAVEMENT REMOVAL - 4" (NOMINAL), ITEM AR401900
- ④ BITUMINOUS PAVEMENT MILLING, ITEM AR401650
- ⑤ PROPOSED SUBGRADE PREPARATION:
CUT AREAS - REMOVE TOPSOIL, ADDITIONAL CUT AS NECESSARY TO FINISHED SUBGRADE ELEVATION. ADDITIONAL UNDERCUT IN AREAS AS DETERMINED BY ROLL TEST.
FILL AREAS - REMOVE TOPSOIL, ADDITIONAL UNDERCUT IN AREAS AS DETERMINED BY ROLL TEST.
- ⑥ PROPOSED BITUMINOUS SURFACE - 2", ITEM AR401610
- ⑦ PROPOSED BITUMINOUS BASE COURSE - 2", ITEM AR201610
- ⑧ PROPOSED BITUMINOUS BASE COURSE - 1.5", ITEM AR201620
- ⑨ PROPOSED BITUMINOUS BASE COURSE, LEVELING, 2" (NOMINAL), ITEM AR201620
- ⑩ PROPOSED BITUMINOUS PRIME COAT, ITEM AR602510
- ⑪ PROPOSED BITUMINOUS TACK COAT, ITEM AR603510
- ⑫ PROPOSED CRACK CONTROL MATERIAL (ROADWAY), ITEM ARB00996
- ⑬ PROPOSED CRUSHED AGGREGATE BASE COURSE - 10", ITEM AR209610
- ⑭ PROPOSED CRUSHED AGGREGATE BASE COURSE, THICKNESS VARIES, ITEM AR209510
- ⑮ POROUS BACKFILL NO. 2, ITEM AR705412
- ⑯ PROPOSED 4" PERFORATED UNDERDRAIN, ITEM AR705504
- ⑰ PROPOSED SODDING, ITEM AR904510
- ⑱ PROPOSED 4" TOPSOIL, ITEMS AR905510 AND AR905520
- ⑲ PROPOSED STORM SEWER, SEE PLAN AND SCHEDULE
- ⑳ EXISTING AGGREGATE BASE COURSE TO BE REMOVED, PAID UNDER ITEM AR152410
- ㉑ PROPOSED CRUSHED AGGREGATE DRAINAGE LAYER-4", ITEM ARB00961
- ㉒ PROPOSED SEPARATION FABRIC, ITEM AR156513

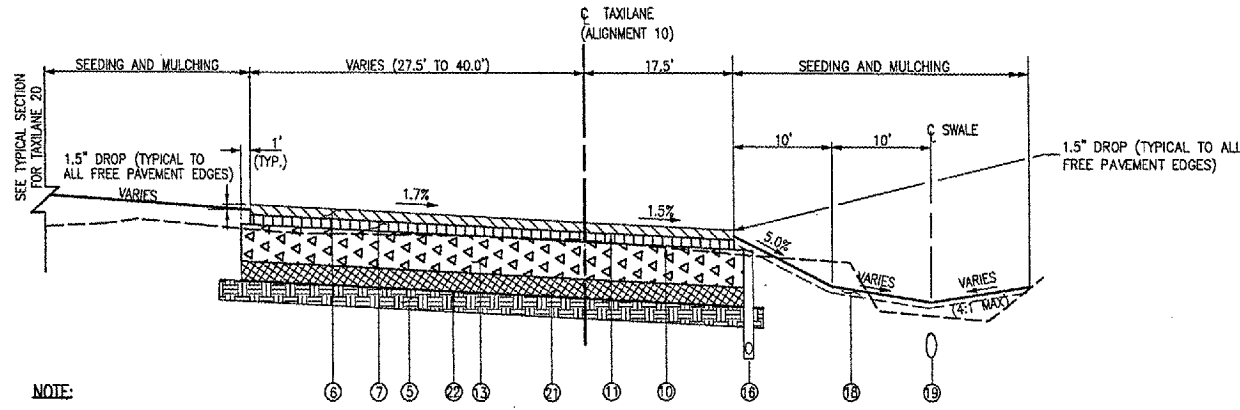

NOTE:

VEGETATION MUST BE REMOVED AT ALL PROPOSED PAVEMENT AREAS, COST INCIDENTAL TO ITEM AR152410.

TYPICAL SECTION - TAXILANE 10
(SECTION SHOWN LOOKING SOUTHEAST)

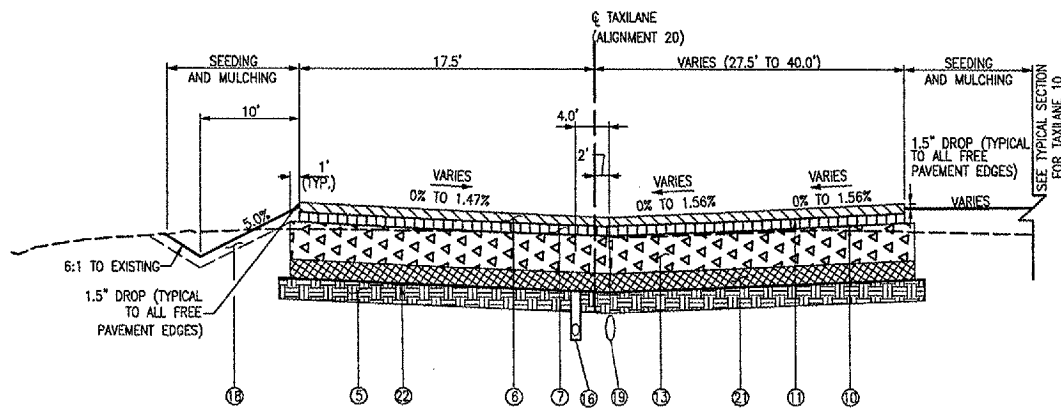

TYPICAL SECTION - TAXILANE 20
(SECTION SHOWN LOOKING SOUTHEAST)

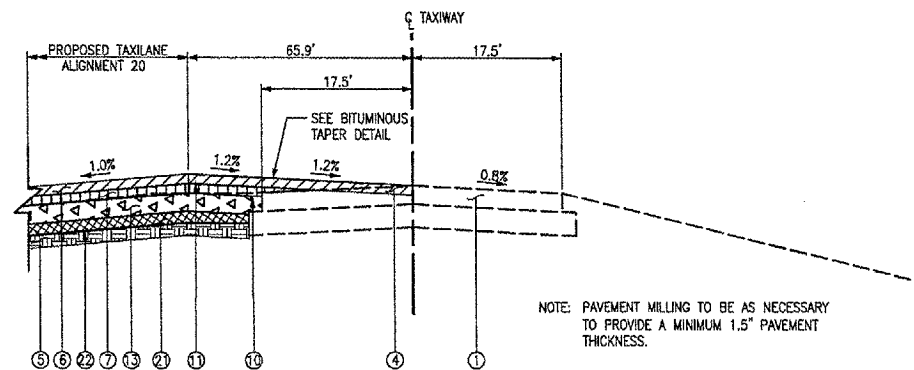

SECTION - SOUTHEAST ACCESS TAXIWAY AT TAXILANE 20
(SECTION SHOWN LOOKING EAST)

NOTE: PAVEMENT MILLING TO BE AS NECESSARY TO PROVIDE A MINIMUM 1.5" PAVEMENT THICKNESS.

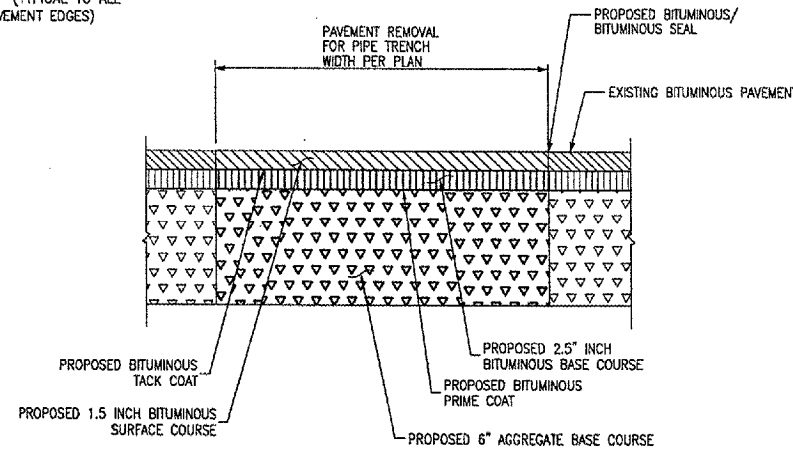

NOTES

- 1. REMOVED BITUMINOUS PAVEMENT AND AGGREGATE BASE TO BE DISPOSED OF AT AN OFFSITE LOCATION, COST INCIDENTAL TO REMOVE AND REPLACE BITUMINOUS PAVEMENT.
- 2. ALL ITEMS ASSOCIATED WITH THE BITUMINOUS PAVEMENT REMOVAL AND REPLACEMENT TO BE INCLUDED IN ITEM AR401916 EXCEPT FOR BITUMINOUS PAVEMENT SAWING WHICH IS TO BE PAID AS ITEM AR401665 AND BITUMINOUS/BITUMINOUS SEAL PAID AS ITEM AR401660.

BITUMINOUS PAVEMENT REMOVAL AND REPLACEMENT - TYPE B

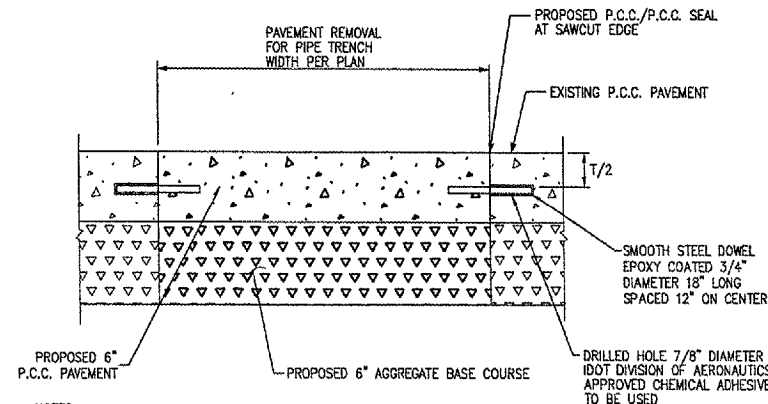

NOTES

- 1. REMOVED P.C.C. PAVEMENT AND AGGREGATE BASE TO BE DISPOSED OF AT AN OFFSITE LOCATION, COST INCIDENTAL TO REMOVE AND REPLACE BITUMINOUS PAVEMENT.
- 2. ALL ITEMS ASSOCIATED WITH THE P.C.C. PAVEMENT REMOVAL AND REPLACEMENT TO BE INCLUDED IN ITEM AR501910 EXCEPT FOR P.C.C. PAVEMENT SAWING WHICH IS TO BE PAID AS ITEM AR501665.
- 3. P.C.C. PAVEMENT JOINTS TO MATCH EXISTING.

P.C.C. PAVEMENT PATCH DETAIL

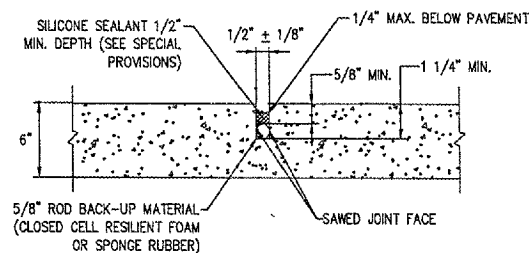

NOTE:

P.C.C. JOINT SEALING FOR PAVEMENT PATCH IS INCIDENTAL TO ITEM AR501910.

P.C.C./P.C.C. SEAL

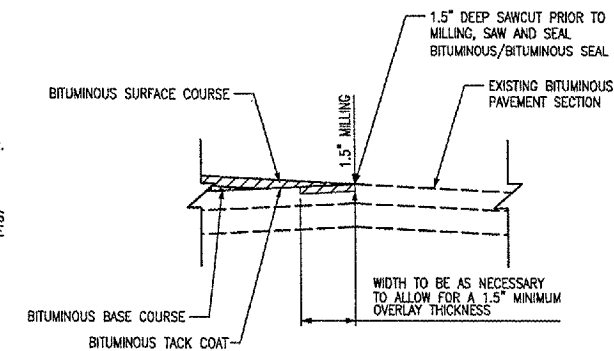

BITUMINOUS TAPER DETAIL

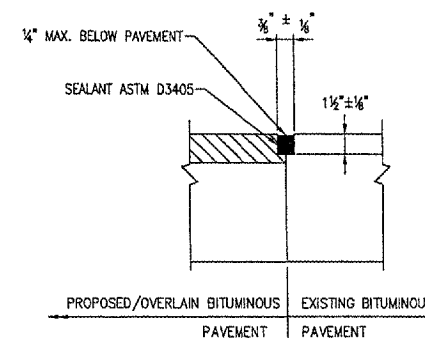

PROPOSED BITUMINOUS/BITUMINOUS SEAL

NOTE: BITUMINOUS JOINT SEALING TO BE PAID UNDER ITEM AR401660.

No.	Drawing Issue Description	Date	By

Date: MAY 06, 2005
Sheet Title: TYPICAL SECTIONS NEW HANGAR PAVEMENTS

TYPICAL SECTIONS NEW HANGAR PAVEMENTS

831-04TXD	Project Number
AAP	02/28/05
Layout By	Date
AAP	02/28/05
Designed By	Date
TMM	04/07/05
Reviewed By	Date
AAP	
Drawn By	