

F.A.P. RTE	SECTION	COUNTY	TOTAL SHEETS	SHEET NO.
869	(103)I	SALINE	64	30
STA.	TO STA.			
FED. ROAD DIST. NO.	ILLINOIS	FED. AID PROJECT		
CONTRACT NO. 98896				

DETAILS OF PIPE UNDERDRAINS

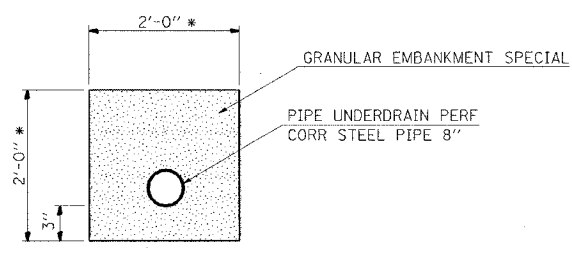
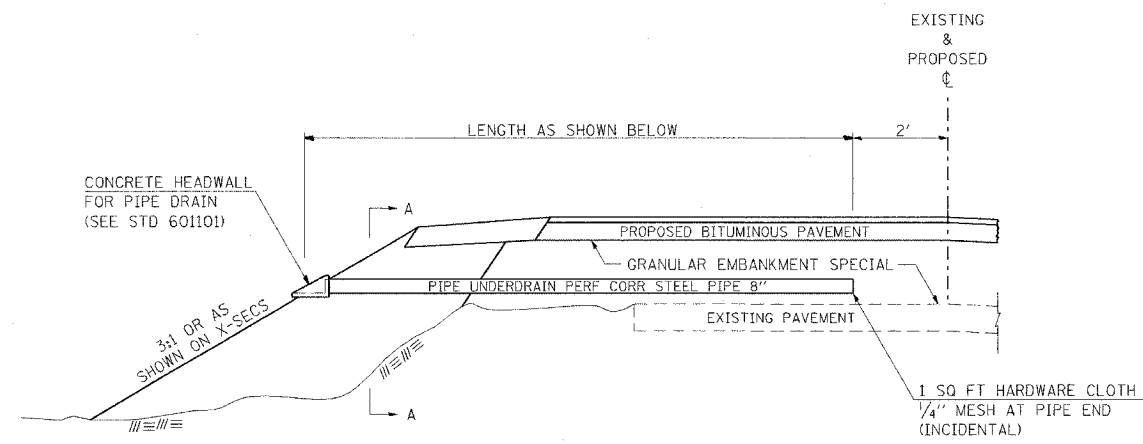

*OR AS DIRECTED BY THE ENGINEER
SECTION A-A

LOCATIONS TO BE USED

STATION	LENGTH FEET		CONCRETE HEADWALL EACH
	LT.	RT.	
1026+50	28	28	2
1035+50	25	27	2
1037+00	29	30	2
1040+00	30	30	2
1043+00	30	30	2
1045+00	24	23	2
1052+50	19	20	2
1059+82	20		1
1060+00		22	1
TOTAL	415		16

REVISIONS
 DRAWN 12-28-90
 REVISED 11-25-91
 REVISED 12-8-92
 REVISED 12-18-01
 STD. 9-73

DETAIL: GRANULAR EMBANKMENT, SPECIAL AT PROPOSED CROSSROAD CULVERTS

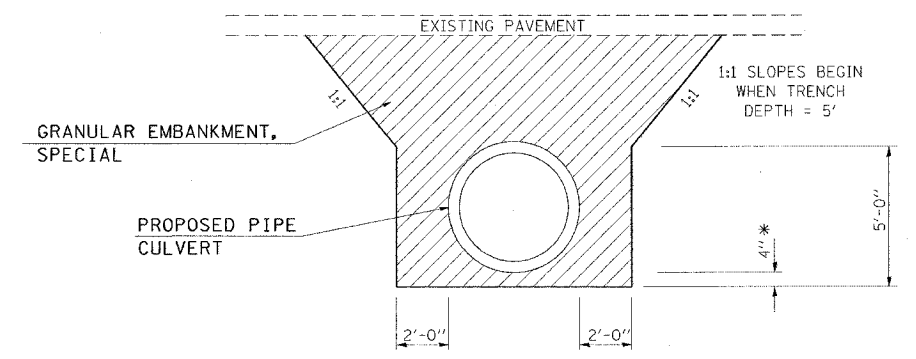

* THE ℓ OF THE EXISTING 4' X 4' BOX CULVERT TO BE REMOVED AT STA. 1045+10.3 IS LOWER THAN THE ℓ OF THE PROPOSED PIPE CULVERT TO BE PLACED AT THIS STATION. THEREFORE, ADDITIONAL BEDDING MATERIAL WILL BE REQUIRED. THE MATERIAL USED FOR ADDITIONAL BEDDING SHALL BE GRANULAR EMBANKMENT, SPECIAL. THE ADDITIONAL GRANULAR EMBANKMENT, SPECIAL USED FOR THE BEDDING MATERIAL WILL NOT BE PAID FOR SEPARATELY, BUT SHALL BE INCLUDED IN THE COST OF BOX CULVERT REMOVAL.

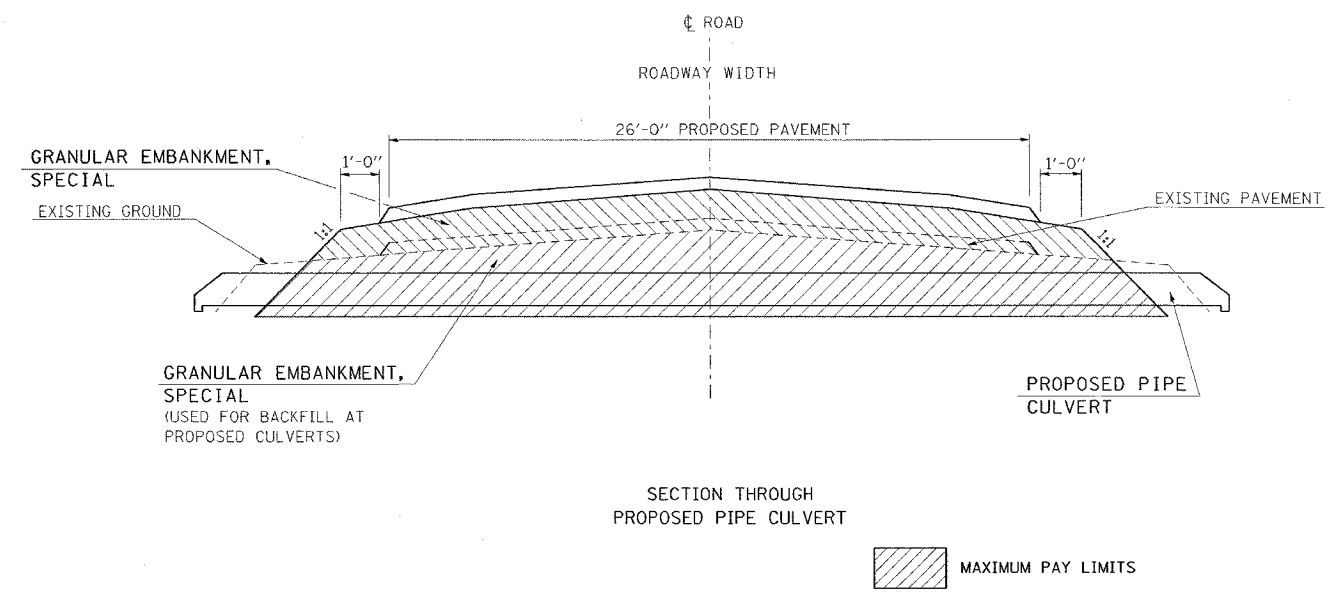

FEBRUARY 14, 2005 MORING
 D903502/D903502P3.DGN