

**If you plan to submit a bid directly to the Department of Transportation**

**PREQUALIFICATION**

Any contractor who desires to become pre-qualified to bid on work advertised by IDOT must submit the properly completed pre-qualification forms to the Bureau of Construction no later than 4:30 p.m. prevailing time twenty-one days prior to the letting of interest. This pre-qualification requirement applies to first time contractors, contractors renewing expired ratings, contractors maintaining continuous pre-qualification or contractors requesting revised ratings. To be eligible to bid, existing pre-qualification ratings must be effective through the date of letting.

**REQUESTS FOR AUTHORIZATION TO BID**

Contractors downloading and/or ordering CD-ROM's and are wanting to bid on items included in a particular letting must submit the properly completed "Request for Authorization to Bid/or Not For Bid Status" (BDE 124INT) and the ORIGINAL, signed and notarized, "Affidavit of Availability" (BC 57) to the proper office no later than 4:30 p.m. prevailing time, three (3) days prior to the letting date.

**WHO CAN BID ?**

Bids will be accepted from only those companies that request and receive written **Authorization to Bid** from IDOT's Central Bureau of Construction.

**WHAT CONSTITUTES WRITTEN AUTHORIZATION TO BID?** When a prospective prime bidder submits a "Request for Authorization to Bid/or Not For Bid Status"(BDE 124INT) he/she must indicate at that time which items are being requested For Bidding purposes. Only those items requested For Bidding will be analyzed. After the request has been analyzed, the bidder will be issued a **Proposal Denial and/or Authorization Form**, approved by the Central Bureau of Construction, that indicates which items have been approved For Bidding. If **Authorization to Bid** cannot be approved, the **Proposal Denial and/or Authorization Form** will indicate the reason for denial.

**ABOUT AUTHORIZATION TO BID:** Firms that have not received an authorization form within a reasonable time of complete and correct original document submittal should contact the department as to status. This is critical in the week before the letting. These documents must be received three days before the letting date. Firms unsure as to authorization status should call the Prequalification Section of the Bureau of Construction at the number listed at the end of these instructions.

**ADDENDA AND REVISIONS:** It is the contractor's responsibility to determine which, if any, addenda or revisions pertain to any project they may be bidding. Failure to incorporate all relevant addenda or revisions may cause the bid to be declared unacceptable.

Each addendum will be placed with the contract number. Addenda and revisions will also be placed on the Addendum/Revision Checklist and each subscription service subscriber will be notified by e-mail of each addendum and revision issued.

The Internet is the Department's primary way of doing business. The subscription server e-mails are an added courtesy the Department provides. It is suggested that bidder check IDOT's website <http://www.dot.il.gov/desenv/delett.html> before submitting final bid information.

**IDOT is not responsible for any e-mail related failures.**

Addenda Questions may be directed to the Contracts Office at (217)782-7806 or [D&Econtracts@dot.il.gov](mailto:D&Econtracts@dot.il.gov)

Technical Questions about downloading these files may be directed to Tim Garman (217)524-1642 or [garmantr@dot.il.gov](mailto:garmantr@dot.il.gov).

**WHAT MUST BE INCLUDED WHEN BIDS ARE SUBMITTED?:** Bidders need not return the entire proposal when bids are submitted. That portion of the proposal that must be returned includes the following:

1. All documents from the Proposal Cover Sheet through the Proposal Bid Bond
2. Other special documentation and/or information that may be required by the contract special provisions

All proposal documents, including Proposal Guaranty Checks or Proposal Bid Bonds, should be stapled together to prevent loss when bids are processed by IDOT personnel.

**ABOUT SUBMITTING BIDS:** It is recommended that bidders deliver bids in person to insure they arrive at the proper location prior to the time specified for the receipt of bids. Any bid received at the place of letting after the time specified will not be accepted.

**WHO SHOULD BE CALLED IF ASSISTANCE IS NEEDED?**

<b>Questions Regarding</b>	<b>Call</b>
Prequalification and/or Authorization to Bid	(217)782-3413
Preparation and submittal of bids	(217)782-7806
Mailing of plans and proposals	(217)782-7806
Electronic plans and proposals	(217)524-1642

**ADDENDUMS AND REVISIONS TO THE PROPOSAL FORMS**

Planholders should verify that they have received and incorporated the addendum and/or revision prior to submitting their bid. Failure by the bidder to include an addendum could result in a bid being rejected as irregular.

# 196

RETURN WITH BID

Proposal Submitted By
Name
Address
City

## Letting June 17, 2005

**BIDDERS NEED NOT RETURN THE ENTIRE PROPOSAL**  
(See instructions inside front cover)

### NOTICE TO PROSPECTIVE BIDDERS

This proposal can be used for bidding purposes by only those companies that request and receive written AUTHORIZATION TO BID from IDOT's Central Bureau of Construction.

(SEE INSTRUCTIONS ON THE INSIDE OF COVER)

# Notice To Bidders, Specifications, Proposal, Contract and Contract Bond



**Illinois Department  
of Transportation**

Springfield, Illinois 62764

**Contract No. 97251  
MADISON County  
Section 02-00180-01-PV (Granite City)  
Route FAU 9089 (20th Street)  
Project M-5011(178)  
District 8 Construction Funds**

PLEASE MARK THE APPROPRIATE BOX BELOW:

- A Bid Bond is included.
- A Cashier's Check or a Certified Check is included

Prepared by

F

Checked by

(Printed by authority of the State of Illinois)

---

---

## INSTRUCTIONS

**ABOUT IDOT PROPOSALS:** All proposals issued by IDOT are potential bidding proposals. Each proposal contains all Certifications and Affidavits, a Proposal Signature Sheet and a Proposal Bid Bond required for Prime Contractors to submit a bid after written **Authorization to Bid** has been issued by IDOT's Central Bureau of Construction.

**WHO CAN BID?:** Bids will be accepted from only those companies that request and receive written **Authorization to Bid** from IDOT's Central Bureau of Construction. To request authorization, a potential bidder must complete and submit Part B of the Request for Authorization to Bid/or Not For Bid Status form (BDE 124 INT) and submit an original Affidavit of Availability (BC 57).

**WHAT CONSTITUTES WRITTEN AUTHORIZATION TO BID?:** When a prospective prime bidder submits a "Request for Proposal Forms and Plans" he/she must indicate at that time which items are being requested For Bidding purposes. Only those items requested For Bidding will be analyzed. After the request has been analyzed, the bidder will be issued a **Proposal Denial and/or Authorization Form**, approved by the Central Bureau of Construction, that indicates which items have been approved For Bidding. If **Authorization to Bid** cannot be approved, the **Proposal Denial and/or Authorization Form** will indicate the reason for denial. If a contractor has requested to bid but has not received a **Proposal Denial and/or Authorization Form**, they should contact the Central Bureau of Construction in advance of the letting date.

**WHAT MUST BE INCLUDED WHEN BIDS ARE SUBMITTED?:** Bidders need not return the entire proposal when bids are submitted. That portion of the proposal that must be returned includes the following:

1. All documents from the Proposal Cover Sheet through the Proposal Bid Bond
2. Other special documentation and/or information that may be required by the contract special provisions

All proposal documents, including Proposal Guaranty Checks or Proposal Bid Bonds, should be stapled together to prevent loss when bids are processed by IDOT personnel.

**ABOUT SUBMITTING BIDS:** It is recommended that bidders deliver bids in person to insure they arrive at the proper location prior to the time specified for the receipt of bids. Any bid received at the place of letting after the time specified will not be accepted.

### WHO SHOULD BE CALLED IF ASSISTANCE IS NEEDED?

Questions Regarding	Call
Prequalification and/or Authorization to Bid	217/782-3413
Preparation and submittal of bids	217/782-7806
Mailing of CD-ROMS	217/782-7806

RETURN WITH BID



PROPOSAL

TO THE DEPARTMENT OF TRANSPORTATION

1. Proposal of \_\_\_\_\_  
\_\_\_\_\_

for the improvement identified and advertised for bids in the Invitation for Bids as:

**Contract No. 97251  
MADISON County  
Section 02-00180-01-PV (Granite City)  
Project M-5011(178)  
Route FAU 9089 (20th Street)  
District 8 Construction Funds**

**Improvement consists of 0.08 miles of pavement removal, PCC pavement 10", curb and gutter, sidewalks, traffic signal upgrades and storm sewers along 20th Street from the intersection of Madison Avenue and 20th Street to the intersection of Iowa Street and 20th Street in Granite City.**

2. The undersigned bidder will furnish all labor, material and equipment to complete the above described project in a good and workmanlike manner as provided in the contract documents provided by the Department of Transportation. This proposal will become part of the contract and the terms and conditions contained in the contract documents shall govern performance and payments.

**RETURN WITH BID**

3. **ASSURANCE OF EXAMINATION AND INSPECTION/WAIVER.** The undersigned further declares that he/she has carefully examined the proposal, plans, specifications, form of contract and contract bond, and special provisions, and that he/she has inspected in detail the site of the proposed work, and that he/she has familiarized themselves with all of the local conditions affecting the contract and the detailed requirements of construction, and understands that in making this proposal he/she waives all right to plead any misunderstanding regarding the same.
  
4. **EXECUTION OF CONTRACT AND CONTRACT BOND.** The undersigned further agrees to execute a contract for this work and present the same to the department within fifteen (15) days after the contract has been mailed to him/her. The undersigned further agrees that he/she and his/her surety will execute and present within fifteen (15) days after the contract has been mailed to him/her contract bond satisfactory to and in the form prescribed by the Department of Transportation, in the penal sum of the full amount of the contract, guaranteeing the faithful performance of the work in accordance with the terms of the contract.
  
5. **PROPOSAL GUARANTY.** Accompanying this proposal is either a bid bond on the department form, executed by a corporate surety company satisfactory to the department, or a proposal guaranty check consisting of a bank cashier's check or a properly certified check for not less than 5 per cent of the amount bid or for the amount specified in the following schedule:

<u>Amount of Bid</u>		<u>Proposal Guaranty</u>	<u>Amount of Bid</u>		<u>Proposal Guaranty</u>	
Up to	\$5,000 .....	\$150	\$2,000,000	to	\$3,000,000 .....	\$100,000
\$5,000	to \$10,000 .....	\$300	\$3,000,000	to	\$5,000,000 .....	\$150,000
\$10,000	to \$50,000 .....	\$1,000	\$5,000,000	to	\$7,500,000 .....	\$250,000
\$50,000	to \$100,000 .....	\$3,000	\$7,500,000	to	\$10,000,000 .....	\$400,000
\$100,000	to \$150,000 .....	\$5,000	\$10,000,000	to	\$15,000,000 .....	\$500,000
\$150,000	to \$250,000 .....	\$7,500	\$15,000,000	to	\$20,000,000 .....	\$600,000
\$250,000	to \$500,000 .....	\$12,500	\$20,000,000	to	\$25,000,000 .....	\$700,000
\$500,000	to \$1,000,000 .....	\$25,000	\$25,000,000	to	\$30,000,000 .....	\$800,000
\$1,000,000	to \$1,500,000 .....	\$50,000	\$30,000,000	to	\$35,000,000 .....	\$900,000
\$1,500,000	to \$2,000,000 .....	\$75,000	over		\$35,000,000 .....	\$1,000,000

Bank cashier's checks or properly certified checks accompanying proposals shall be made payable to the Treasurer, State of Illinois, when the state is awarding authority; the county treasurer, when a county is the awarding authority; or the city, village, or town treasurer, when a city, village, or town is the awarding authority.

If a combination bid is submitted, the proposal guaranties which accompany the individual proposals making up the combination will be considered as also covering the combination bid.

The amount of the proposal guaranty check is \_\_\_\_\_ \$( \_\_\_\_\_ ). If this proposal is accepted and the undersigned shall fail to execute a contract bond as required herein, it is hereby agreed that the amount of the proposal guaranty shall become the property of the State of Illinois, and shall be considered as payment of damages due to delay and other causes suffered by the State because of the failure to execute said contract and contract bond; otherwise, the bid bond shall become void or the proposal guaranty check shall be returned to the undersigned.

**Attach Cashier's Check or Certified Check Here**

In the event that one proposal guaranty check is intended to cover two or more proposals, the amount must be equal to the sum of the proposal guaranties which would be required for each individual proposal. If the guaranty check is placed in another proposal, state below where it may be found.

The proposal guaranty check will be found in the proposal for:

Item \_\_\_\_\_

Section No. \_\_\_\_\_

County \_\_\_\_\_

**Mark the proposal cover sheet as to the type of proposal guaranty submitted.**

BD 354 (Rev. 11/2001)

**RETURN WITH BID**

6. **COMBINATION BIDS.** The undersigned further agrees that if awarded the contract for the sections contained in the following combination, he/she will perform the work in accordance with the requirements of each individual proposal comprising the combination bid specified in the schedule below, and that the combination bid shall be prorated against each section in proportion to the bid submitted for the same. If an error is found to exist in the gross sum bid for one or more of the individual sections included in a combination, the combination bid shall be corrected as provided in the specifications.

**When a combination bid is submitted, the schedule below must be completed in each proposal comprising the combination.**

**If alternate bids are submitted for one or more of the sections comprising the combination, a combination bid must be submitted for each alternate.**

**Schedule of Combination Bids**

Combination No.	Sections Included in Combination	Combination Bid	
		Dollars	Cents

7. **SCHEDULE OF PRICES.** The undersigned bidder submits herewith, in accordance with the rules and instructions, a schedule of prices for the items of work for which bids are sought. The unit prices bid are in U.S. dollars and cents, and all extensions and summations have been made. The bidder understands that the quantities appearing in the bid schedule are approximate and are provided for the purpose of obtaining a gross sum for the comparison of bids. If there is an error in the extension of the unit prices, the unit prices shall govern. Payment to the contractor awarded the contract will be made only for actual quantities of work performed and accepted or materials furnished according to the contract. The scheduled quantities of work to be done and materials to be furnished may be increased, decreased or omitted as provided elsewhere in the contract.
8. **CERTIFICATE OF AUTHORITY.** The undersigned bidder, if a business organized under the laws of another State, assures the Department that it will furnish a copy of its certificate of authority to do business in the State of Illinois with the return of the executed contract and bond. Failure to furnish the certificate within the time provided for execution of an awarded contract may be cause for cancellation of the award and forfeiture of the proposal guaranty to the State.

COUNTY NAME	CODE	DIST	SECTION NUMBER	PROJECT NUMBER	ROUTE
MADISON	119	08	02-00180-01-PV (GRANITE CITY)	M-5011/178/000	FAU 9089

ITEM NUMBER	PAY ITEM DESCRIPTION	UNIT OF MEASURE	QUANTITY	UNIT PRICE		TOTAL PRICE	
				DOLLARS	CENTS	DOLLARS	CTS
XX004949	INCID BIT SUR SUPER	TON	38.000 X				
XX004951	CONCRETE STAIRS	L SUM	1.000 X				
XX104100	CONN EX MANHOLE	EACH	3.000 X				
X0301183	GEOMETRIC PROG LOUVER	EACH	2.000 X				
X0323336	LED SF RETRO RED BALL	EACH	6.000 X				
X0323337	LED SF RETRO GRN BALL	EACH	6.000 X				
X0323418	LED SF RETRO YEL BALL	EACH	6.000 X				
X0323420	LED SF RETRO GRN AROW	EACH	2.000 X				
X0323421	LED SF RETRO WALK SIG	EACH	1.000 X				
X0323422	LED SF RETRO DONT WLK	EACH	1.000 X				
X8801310	SH P LED 1F 3S MAM	EACH	6.000 X				
X8801350	SH P LED 1F 4S MAM	EACH	2.000 X				
X8801415	SH P LED 2F 3S BM	EACH	2.000 X				
X8810395	PED SH P LED 1F BM	EACH	3.000 X				
X8810495	PED SH P LED 2F BM	EACH	2.000 X				



FAU 9089  
 02-00180-01-PV (GRANITE CITY)  
 MADISON

ILLINOIS DEPARTMENT OF TRANSPORTATION  
 SCHEDULE OF PRICES  
 CONTRACT NUMBER - 97251

ECMS002 DTGECM03 ECMR003 PAGE 2  
 RUN DATE - 05/17/05  
 RUN TIME - 183235

ITEM NUMBER	PAY ITEM DESCRIPTION	UNIT OF MEASURE	QUANTITY	UNIT PRICE		TOTAL PRICE	
				DOLLARS	CENTS	DOLLARS	CTS
X8880010	ADA PED PUSH-BUTTON	EACH	8.000 X	=			
Z0000990	AGG FOR TEMP ACCESS	TON	250.000 X	=			
20200100	EARTH EXCAVATION	CU YD	601.000 X	=			
20800150	TRENCH BACKFILL	CU YD	301.000 X	=			
28000500	INLET & PIPE PROTECT	EACH	13.000 X	=			
30200650	PROCESS MOD SOIL 12	SQ YD	2,995.000 X	=			
30201500	LIME	TON	74.000 X	=			
31100300	SUB GRAN MAT A 4	SQ YD	2,995.000 X	=			
35101400	AGG BASE CSE B	TON	117.000 X	=			
40300100	BIT MATLS PR CT	GALLON	32.000 X	=			
40600990	TEMPORARY RAMP	SQ YD	524.000 X	=			
42000500	PCC PVT 10	SQ YD	2,769.000 X	=			
42001200	PAVEMENT FABRIC	SQ YD	2,769.000 X	=			
42001300	PROTECTIVE COAT	SQ YD	3,487.000 X	=			
42300400	PCC DRIVEWAY PAVT 8	SQ YD	81.000 X	=			

FAU 9089  
 02-00180-01-PV (GRANITE CITY)  
 MADISON

ILLINOIS DEPARTMENT OF TRANSPORTATION  
 SCHEDULE OF PRICES  
 CONTRACT NUMBER - 97251

ECMS002 DTGECM03 ECMR003 PAGE 3  
 RUN DATE - 05/17/05  
 RUN TIME - 183235

ITEM NUMBER	PAY ITEM DESCRIPTION	UNIT OF MEASURE	QUANTITY	UNIT PRICE		TOTAL PRICE	
				DOLLARS	CENTS	DOLLARS	CTS
42400100	PC CONC SIDEWALK 4	SQ FT	4,106.000 X	=		=	
44000100	PAVEMENT REM	SQ YD	3,078.000 X	=		=	
44000200	DRIVE PAVEMENT REM	SQ YD	126.000 X	=		=	
44000300	CURB REM	FOOT	839.000 X	=		=	
44000600	SIDEWALK REM	SQ FT	2,900.000 X	=		=	
44003100	MEDIAN REMOVAL	SQ FT	1,028.000 X	=		=	
550B0070	STORM SEW CL B 1 15	FOOT	218.000 X	=		=	
550B0090	STORM SEW CL B 1 18	FOOT	63.000 X	=		=	
550B0110	STORM SEW CL B 1 21	FOOT	75.000 X	=		=	
550B0340	STORM SEW CL B 2 12	FOOT	79.000 X	=		=	
550B0360	STORM SEW CL B 2 15	FOOT	34.000 X	=		=	
550B0380	STORM SEW CL B 2 18	FOOT	44.000 X	=		=	
550B0400	STORM SEW CL B 2 21	FOOT	63.000 X	=		=	
550B0410	STORM SEW CL B 2 24	FOOT	75.000 X	=		=	
55100300	STORM SEWER REM 8	FOOT	30.000 X	=		=	

FAU 9089  
 02-00180-01-PV (GRANITE CITY)  
 MADISON

ILLINOIS DEPARTMENT OF TRANSPORTATION  
 SCHEDULE OF PRICES  
 CONTRACT NUMBER - 97251

ECMS002 DTGECM03 ECMR003 PAGE 4  
 RUN DATE - 05/17/05  
 RUN TIME - 183235

ITEM NUMBER	PAY ITEM DESCRIPTION	UNIT OF MEASURE	QUANTITY	UNIT PRICE		TOTAL PRICE	
				DOLLARS	CENTS	DOLLARS	CTS
55100500	STORM SEWER REM 12	FOOT	33.000 X				
60219300	MAN TA 4 DIA T11F&G	EACH	2.000 X				
60240310	INLETS TB T11F&G	EACH	11.000 X				
60255800	MAN ADJ NEW T1F CL	EACH	4.000 X				
60500060	REMOV INLETS	EACH	2.000 X				
60500305	FILL INLETS	EACH	5.000 X				
60600605	CONC CURB TB	FOOT	96.000 X				
60603800	COMB CC&G TB6.12	FOOT	594.000 X				
60605900	COMB CC&G TB9.12	FOOT	290.000 X				
70101700	TRAF CONT & PROT	L SUM	1.000 X				
70300100	SHORT-TERM PAVT MKING	FOOT	1,650.000 X				
70300210	TEMP PVT MK LTR & SYM	SQ FT	270.000 X				
70300220	TEMP PVT MK LINE 4	FOOT	3,258.000 X				
70300240	TEMP PVT MK LINE 6	FOOT	580.000 X				
70300260	TEMP PVT MK LINE 12	FOOT	162.000 X				

FAU 9089  
 02-00180-01-PV (GRANITE CITY)  
 MADISON

ILLINOIS DEPARTMENT OF TRANSPORTATION  
 SCHEDULE OF PRICES  
 CONTRACT NUMBER - 97251

ECMS002 DTGECM03 ECMR003 PAGE 5  
 RUN DATE - 05/17/05  
 RUN TIME - 183235

ITEM NUMBER	PAY ITEM DESCRIPTION	UNIT OF MEASURE	QUANTITY	UNIT PRICE		TOTAL PRICE	
				DOLLARS	CENTS	DOLLARS	CTS
70301000	WORK ZONE PAVT MK REM	SQ FT	543.000 X	=			
72000100	SIGN PANEL T1	SQ FT	19.000 X	=			
78000200	THPL PVT MK LINE 4	FOOT	1,542.000 X	=			
78002100	PREF PL PM TA LTR-SYM	SQ FT	270.000 X	=			
78005110	EPOXY PVT MK LINE 4	FOOT	1,824.000 X	=			
78005130	EPOXY PVT MK LINE 6	FOOT	580.000 X	=			
78005150	EPOXY PVT MK LINE 12	FOOT	162.000 X	=			
80500100	SERV INSTALL TY A	EACH	1.000 X	=			
81012300	CON T 1 PVC	FOOT	76.000 X	=			
81012700	CON T 2 1/2 PVC	FOOT	10.000 X	=			
81400400	CONC HANDHOLE	EACH	1.000 X	=			
81500200	TR & BKFIL F ELECT WK	FOOT	86.000 X	=			
87301215	ELCBL C SIGNAL 14 2C	FOOT	895.000 X	=			
87301225	ELCBL C SIGNAL 14 3C	FOOT	966.000 X	=			
87301245	ELCBL C SIGNAL 14 5C	FOOT	1,629.000 X	=			

FAU 9089  
 02-00180-01-PV (GRANITE CITY)  
 MADISON

ILLINOIS DEPARTMENT OF TRANSPORTATION  
 SCHEDULE OF PRICES  
 CONTRACT NUMBER - 97251

ECMS002 DTGECM03 ECMR003 PAGE 6  
 RUN DATE - 05/17/05  
 RUN TIME - 183235

ITEM NUMBER	PAY ITEM DESCRIPTION	UNIT OF MEASURE	QUANTITY	UNIT PRICE		TOTAL PRICE	
				DOLLARS	CENTS	DOLLARS	CTS
87301255	ELCBL C SIGNAL 14 7C	FOOT	560.000 X				
87301305	ELCBL C LEAD 14 1PR	FOOT	1,020.000 X				
87301815	ELCBL C SERV 6 3C	FOOT	22.000 X				
87502680	TS POST A 14	EACH	1.000 X				
87700190	S MAA & P 30	EACH	1.000 X				
87700240	S MAA & P 40	EACH	1.000 X				
87800415	CONC FDN TY E 36D	FOOT	24.000 X				
87900100	DRILL EX FOUNDATION	EACH	1.000 X				
87900200	DRILL EX HANDHOLE	EACH	9.000 X				
88200400	TS BACKPLATE F PLAST	EACH	8.000 X				
88500100	INDUCTIVE LOOP DETECT	EACH	10.000 X				
88600100	DET LOOP T1	FOOT	1,819.000 X				
89502200	MOD EX CONTR	EACH	1.000 X				
89502300	REM ELCBL FR CON	FOOT	1,480.000 X				
89502375	REMOV EX TS EQUIP	EACH	1.000 X				

FAU 9089  
 02-00180-01-PV (GRANITE CITY)  
 MADISON

ILLINOIS DEPARTMENT OF TRANSPORTATION  
 SCHEDULE OF PRICES  
 CONTRACT NUMBER - 97251

ECMS002 DTGECM03 ECMR003 PAGE 7  
 RUN DATE - 05/17/05  
 RUN TIME - 183235

ITEM NUMBER	PAY ITEM DESCRIPTION	UNIT OF MEASURE	QUANTITY	UNIT PRICE		TOTAL PRICE	
				DOLLARS	CENTS	DOLLARS	CTS
89502385	REMOV EX CONC FDN	EACH	2.000 X				

TOTAL \$

NOTE:

1. EACH PAY ITEM SHOULD HAVE A UNIT PRICE AND A TOTAL PRICE.
2. THE UNIT PRICE SHALL GOVERN IF NO TOTAL PRICE IS SHOWN OR IF THERE IS A DISCREPANCY BETWEEN THE PRODUCT OF THE UNIT PRICE MULTIPLIED BY THE QUANTITY.
3. IF A UNIT PRICE IS OMITTED, THE TOTAL PRICE WILL BE DIVIDED BY THE QUANTITY IN ORDER TO ESTABLISH A UNIT PRICE.
4. A BID MAY BE DECLARED UNACCEPTABLE IF NEITHER A UNIT PRICE NOR A TOTAL PRICE IS SHOWN.

## RETURN WITH BID

### STATE REQUIRED ETHICAL STANDARDS GOVERNING CONTRACT PROCUREMENT: ASSURANCES, CERTIFICATIONS AND DISCLOSURES

#### I. GENERAL

A. Article 50 of the Illinois Procurement Code establishes the duty of all State chief procurement officers, State purchasing officers, and their designees to maximize the value of the expenditure of public moneys in procuring goods, services, and contracts for the State of Illinois and to act in a manner that maintains the integrity and public trust of State government. In discharging this duty, they are charged by law to use all available information, reasonable efforts, and reasonable actions to protect, safeguard, and maintain the procurement process of the State of Illinois.

B. In order to comply with the provisions of Article 50 and to carry out the duty established therein, all bidders are to adhere to ethical standards established for the procurement process, and to make such assurances, disclosures and certifications required by law. By execution of the Proposal Signature Sheet, the bidder indicates that each of the mandated assurances has been read and understood, that each certification is made and understood, and that each disclosure requirement has been understood and completed.

C. In addition to all other remedies provided by law, failure to comply with any assurance, failure to make any disclosure or the making of a false certification shall be grounds for termination of the contract and the suspension or debarment of the bidder.

#### II. ASSURANCES

A. The assurances hereinafter made by the bidder are each a material representation of fact upon which reliance is placed should the Department enter into the contract with the bidder. The Department may terminate the contract if it is later determined that the bidder rendered a false or erroneous assurance, and the surety providing the performance bond shall be responsible for the completion of the contract.

##### B. Felons

1. The Illinois Procurement Code provides:

Section 50-10. Felons. Unless otherwise provided, no person or business convicted of a felony shall do business with the State of Illinois or any state agency from the date of conviction until 5 years after the date of completion of the sentence for that felony, unless no person held responsible by a prosecutorial office for the facts upon which the conviction was based continues to have any involvement with the business.

2. The bidder assures the Department that the award and execution of the contract would not cause a violation of Section 50-10.

##### C. Conflicts of Interest

1. The Illinois Procurement Code provides in pertinent part:

Section 50-13. Conflicts of Interest.

(a) Prohibition. It is unlawful for any person holding an elective office in this State, holding a seat in the General Assembly, or appointed to or employed in any of the offices or agencies of state government and who receives compensation for such employment in excess of 60% of the salary of the Governor of the State of Illinois, or who is an officer or employee of the Capital Development Board or the Illinois Toll Highway Authority, or who is the spouse or minor child of any such person to have or acquire any contract, or any direct pecuniary interest in any contract therein, whether for stationery, printing, paper, or any services, materials, or supplies, that will be wholly or partially satisfied by the payment of funds appropriated by the General Assembly of the State of Illinois or in any contract of the Capital Development Board or the Illinois Toll Highway authority.

(b) Interests. It is unlawful for any firm, partnership, association or corporation, in which any person listed in subsection (a) is entitled to receive (i) more than 7 1/2% of the total distributable income or (ii) an amount in excess of the salary of the Governor, to have or acquire any such contract or direct pecuniary interest therein.

(c) Combined interests. It is unlawful for any firm, partnership, association, or corporation, in which any person listed in subsection (a) together with his or her spouse or minor children is entitled to receive (i) more than 15%, in the aggregate, of the total distributable income or (ii) an amount in excess of 2 times the salary of the Governor, to have or acquire any such contract or direct pecuniary interest therein.

(d) Securities. Nothing in this Section invalidates the provisions of any bond or other security previously offered or to be offered for sale or sold by or for the State of Illinois.

(e) Prior interests. This Section does not affect the validity of any contract made between the State and an officer or employee of the State or member of the General Assembly, his or her spouse, minor child or any combination of those persons if that contract was in existence before his or her election or employment as an officer, member, or employee. The contract is voidable, however, if it cannot be completed within 365 days after the officer, member, or employee takes office or is employed.

The current salary of the Governor is \$150,700.00. Sixty percent of the salary is \$90,420.00.

## RETURN WITH BID

2. The bidder assures the Department that the award and execution of the contract would not cause a violation of Section 50-13, or that an effective exemption has been issued by the Board of Ethics to any individual subject to the Section 50-13 prohibitions pursuant to the provisions of Section 50-20 of the Code and Executive Order Number 3 (1998). Information concerning the exemption process is available from the Department upon request.

### **D. Negotiations**

1. The Illinois Procurement Code provides in pertinent part:

Section 50-15. Negotiations.

(a) It is unlawful for any person employed in or on a continual contractual relationship with any of the offices or agencies of State government to participate in contract negotiations on behalf of that office or agency with any firm, partnership, association, or corporation with whom that person has a contract for future employment or is negotiating concerning possible future employment.

2. The bidder assures the Department that the award and execution of the contract would not cause a violation of Section 50-15, and that the bidder has no knowledge of any facts relevant to the kinds of acts prohibited therein.

### **E. Inducements**

1. The Illinois Procurement Code provides:

Section 50-25. Inducement. Any person who offers or pays any money or other valuable thing to any person to induce him or her not to bid for a State contract or as recompense for not having bid on a State contract is guilty of a Class 4 felony. Any person who accepts any money or other valuable thing for not bidding for a State contract or who withholds a bid in consideration of the promise for the payment of money or other valuable thing is guilty of a Class 4 felony.

2. The bidder assures the Department that the award and execution of the contract would not cause a violation of Section 50-25, and that the bidder has no knowledge of any facts relevant to the kinds of acts prohibited therein.

### **F. Revolving Door Prohibition**

1. The Illinois Procurement Code provides:

Section 50-30. Revolving door prohibition. Chief procurement officers, associate procurement officers, State purchasing officers, their designees whose principal duties are directly related to State procurement, and executive officers confirmed by the Senate are expressly prohibited for a period of 2 years after terminating an affected position from engaging in any procurement activity relating to the State agency most recently employing them in an affected position for a period of at least 6 months. The prohibition includes, but is not limited to: lobbying the procurement process; specifying; bidding; proposing bid, proposal, or contract documents; on their own behalf or on behalf of any firm, partnership, association, or corporation. This Section applies only to persons who terminate an affected position on or after January 15, 1999.

2. The bidder assures the Department that the award and execution of the contract would not cause a violation of Section 50-30, and that the bidder has no knowledge of any facts relevant to the kinds of acts prohibited therein.

### **G. Reporting Anticompetitive Practices**

1. The Illinois Procurement Code provides:

Section 50-40. Reporting anticompetitive practices. When, for any reason, any vendor, bidder, contractor, chief procurement officer, State purchasing officer, designee, elected official, or State employee suspects collusion or other anticompetitive practice among any bidders, offerors, contractors, proposers, or employees of the State, a notice of the relevant facts shall be transmitted to the Attorney General and the chief procurement officer.

2. The bidder assures the Department that it has not failed to report any relevant facts concerning the practices addressed in Section 50-40 which may involve the contract for which the bid is submitted.

### **H. Confidentiality**

1. The Illinois Procurement Code provides:

Section 50-45. Confidentiality. Any chief procurement officer, State purchasing officer, designee, or executive officer who willfully uses or allows the use of specifications, competitive bid documents, proprietary competitive information, proposals, contracts, or selection information to compromise the fairness or integrity of the procurement, bidding, or contract process shall be subject to immediate dismissal, regardless of the Personnel code, any contract, or any collective bargaining agreement, and may in addition be subject to criminal prosecution.

2. The bidder assures the Department that it has no knowledge of any fact relevant to the practices addressed in Section 50-45 which may involve the contract for which the bid is submitted.



## RETURN WITH BID

### **I. Insider Information**

1. The Illinois Procurement Act provides:

Section 50-50. Insider information. It is unlawful for any current or former elected or appointed State official or State employee to knowingly use confidential information available only by virtue of that office or employment for actual or anticipated gain for themselves or another person.

2. The bidder assures the Department that it has no knowledge of any facts relevant to the practices addressed in Section 50-50 which may involve the contract for which the bid is submitted.

### **III. CERTIFICATIONS**

**A.** The certifications hereinafter made by the bidder are each a material representation of fact upon which reliance is placed should the Department enter into the contract with the bidder. The Department may terminate the contract if it is later determined that the bidder rendered a false or erroneous certification, and the surety providing the performance bond shall be responsible for completion of the contract.

### **B. Bribery**

1. The Illinois Procurement Code provides:

Section 50-5. Bribery.

(a) Prohibition. No person or business shall be awarded a contract or subcontract under this Code who:

(1) has been convicted under the laws of Illinois or any other state of bribery or attempting to bribe an officer or employee of the State of Illinois or any other state in that officer's or employee's official capacity; or

(2) has made an admission of guilt of that conduct that is a matter of record but has not been prosecuted for that conduct.

(b) Businesses. No business shall be barred from contracting with any unit of State or local government as a result of a conviction under this Section of any employee or agent of the business if the employee or agent is no longer employed by the business and:

(1) the business has been finally adjudicated not guilty; or

(2) the business demonstrates to the governmental entity with which it seeks to contract, and that entity finds that the commission of the offense was not authorized, requested, commanded, or performed by a director, officer, or high managerial agent on behalf of the business as provided in paragraph (2) of subsection (a) of Section 5-4 of the Criminal Code of 1961.

(c) Conduct on behalf of business. For purposes of this Section, when an official, agent, or employee of a business committed the bribery or attempted bribery on behalf of the business and in accordance with the direction or authorization of a responsible official of the business, the business shall be chargeable with the conduct.

(d) Certification. Every bid submitted to and contract executed by the State shall contain a certification by the contractor that the contractor is not barred from being awarded a contract or subcontract under this Section. A contractor who makes a false statement, material to the certification, commits a Class 3 felony.

2. The bidder certifies that it is not barred from being awarded a contract under Section 50.5.

### **C. Educational Loan**

1. Section 3 of the Educational Loan Default Act provides:

§ 3. No State agency shall contract with an individual for goods or services if that individual is in default, as defined in Section 2 of this Act, on an educational loan. Any contract used by any State agency shall include a statement certifying that the individual is not in default on an educational loan as provided in this Section.

2. The bidder, if an individual as opposed to a corporation, partnership or other form of business organization, certifies that the bidder is not in default on an educational loan as provided in Section 3 of the Act.

### **D. Bid-Rigging/Bid Rotating**

1. Section 33E-11 of the Criminal Code of 1961 provides:

§ 33E-11. (a) Every bid submitted to and public contract executed pursuant to such bid by the State or a unit of local government shall contain a certification by the prime contractor that the prime contractor is not barred from contracting with any unit of State or local government as a result of a violation of either Section 33E-3 or 33E-4 of this Article. The State and units of local government shall provide the appropriate forms for such certification.

## RETURN WITH BID

(b) A contractor who makes a false statement, material to the certification, commits a Class 3 felony.

A violation of Section 33E-3 would be represented by a conviction of the crime of bid-rigging which, in addition to Class 3 felony sentencing, provides that any person convicted of this offense or any similar offense of any state or the United States which contains the same elements as this offense shall be barred for 5 years from the date of conviction from contracting with any unit of State or local government. No corporation shall be barred from contracting with any unit of State or local government as a result of a conviction under this Section of any employee or agent of such corporation if the employee so convicted is no longer employed by the corporation and: (1) it has been finally adjudicated not guilty or (2) if it demonstrates to the governmental entity with which it seeks to contract and that entity finds that the commission of the offense was neither authorized, requested, commanded, nor performed by a director, officer or a high managerial agent in behalf of the corporation.

A violation of Section 33E-4 would be represented by a conviction of the crime of bid-rotating which, in addition to Class 2 felony sentencing, provides that any person convicted of this offense or any similar offense of any state or the United States which contains the same elements as this offense shall be permanently barred from contracting with any unit of State or local government. No corporation shall be barred from contracting with any unit of State or local government as a result of a conviction under this Section of any employee or agent of such corporation if the employee so convicted is no longer employed by the corporation and: (1) it has been finally adjudicated not guilty or (2) if it demonstrates to the governmental entity with which it seeks to contract and that entity finds that the commission of the offense was neither authorized, requested, commanded, nor performed by a director, officer or a high managerial agent in behalf of the corporation.

2. The bidder certifies that it is not barred from contracting with the Department by reason of a violation of either Section 33E-3 or Section 33E-4.

### **E. International Anti-Boycott**

1. Section 5 of the International Anti-Boycott Certification Act provides:

§ 5. State contracts. Every contract entered into by the State of Illinois for the manufacture, furnishing, or purchasing of supplies, material, or equipment or for the furnishing of work, labor, or services, in an amount exceeding the threshold for small purchases according to the purchasing laws of this State or \$10,000.00, whichever is less, shall contain certification, as a material condition of the contract, by which the contractor agrees that neither the contractor nor any substantially-owned affiliated company is participating or shall participate in an international boycott in violation of the provisions of the U.S. Export Administration Act of 1979 or the regulations of the U.S. Department of Commerce promulgated under that Act.

2. The bidder makes the certification set forth in Section 5 of the Act.

### **F. Drug Free Workplace**

1. The Illinois "Drug Free Workplace Act" applies to this contract and it is necessary to comply with the provisions of the "Act" if the contractor is a corporation, partnership, or other entity (including a sole proprietorship) which has 25 or more employees.

2. The bidder certifies that if awarded a contract in excess of \$5,000 it will provide a drug free workplace by:

(a) Publishing a statement notifying employees that the unlawful manufacture, distribution, dispensation, possession or use of a controlled substance, including cannabis, is prohibited in the contractor's workplace; specifying the actions that will be taken against employees for violations of such prohibition; and notifying the employee that, as a condition of employment on such contract, the employee shall abide by the terms of the statement, and notify the employer of any criminal drug statute conviction for a violation occurring in the workplace no later than five (5) days after such conviction.

(b) Establishing a drug free awareness program to inform employees about the dangers of drug abuse in the workplace; the contractor's policy of maintaining a drug free workplace; any available drug counseling, rehabilitation, and employee assistance programs; and the penalties that may be imposed upon employees for drug violations.

(c) Providing a copy of the statement required by subparagraph (1) to each employee engaged in the performance of the contract and to post the statement in a prominent place in the workplace.

(d) Notifying the Department within ten (10) days after receiving notice from an employee or otherwise receiving actual notice of the conviction of an employee for a violation of any criminal drug statute occurring in the workplace.

(e) Imposing or requiring, within 30 days after receiving notice from an employee of a conviction or actual notice of such a conviction, an appropriate personnel action, up to and including termination, or the satisfactory participation in a drug abuse assistance or rehabilitation program approved by a federal, state or local health, law enforcement or other appropriate agency.

(f) Assisting employees in selecting a course of action in the event drug counseling, treatment, and rehabilitation is required and indicating that a trained referral team is in place.

(g) Making a good faith effort to continue to maintain a drug free workplace through implementation of the actions and efforts stated in this certification.

**G. Debt Delinquency**

1. The Illinois Procurement Code provides:

Section 50-11 and 50-12. Debt Delinquency.

The contractor or bidder certifies that it, or any affiliate, is not barred from being awarded a contract under 30 ILCS 500. Section 50-11 prohibits a person from entering into a contract with a State agency if it knows or should know that it, or any affiliate, is delinquent in the payment of any debt to the State as defined by the Debt Collection Board. Section 50-12 prohibits a person from entering into a contract with a State agency if it, or any affiliate, has failed to collect and remit Illinois Use Tax on all sales of tangible personal property into the State of Illinois in accordance with the provisions of the Illinois Use Tax Act. The contractor further acknowledges that the contracting State agency may declare the contract void if this certification is false or if the contractor, or any affiliate, is determined to be delinquent in the payment of any debt to the State during the term of the contract.

**H. Sarbanes-Oxley Act of 2002**

1. The Illinois Procurement Code provides:

Section 50-60(c).

The contractor certifies in accordance with 30 ILCS 500/50-10.5 that no officer, director, partner or other managerial agent of the contracting business has been convicted of a felony under the Sarbanes-Oxley Act of 2002 or a Class 3 or Class 2 felony under the Illinois Securities Law of 1953 for a period of five years prior to the date of the bid or contract. The contractor acknowledges that the contracting agency shall declare the contract void if this certification is false.

**I. ADDENDA**

The contractor or bidder certifies that all relevant addenda have been incorporated in to this contract. Failure to do so may cause the bid to be declared unacceptable.

**J. Section 42 of the Environmental Protection Act**

The contractor certifies in accordance with 30 ILCS 500/50-12 that the bidder or contractor is not barred from being awarded a contract under this Section which prohibits the bidding on or entering into contracts with the State of Illinois or a State agency by a person or business found by a court or the Pollution Control Board to have committed a willful or knowing violation of Section 42 of the Environmental Protection Act for a period of five years from the date of the order. The contractor acknowledges that the contracting agency may declare the contract void if this certification is false.

**K. Apprenticeship and Training Certification (Does not apply to federal aid projects)**

In accordance with the provisions of Section 30-22 (6) of the Illinois Procurement Code, the bidder certifies that it is a participant, either as an individual or as part of a group program, in the approved apprenticeship and training programs applicable to each type of work or craft that the bidder will perform with its own forces. The bidder further certifies for work that will be performed by subcontract that each of its subcontractors submitted for approval either (a) is, at the time of such bid, participating in an approved, applicable apprenticeship and training program; or (b) will, prior to commencement of performance of work pursuant to this contract, begin participation in an approved apprenticeship and training program applicable to the work of the subcontract. The Department, at any time before or after award, may require the production of a copy of each applicable Certificate of Registration issued by the United States Department of Labor evidencing such participation by the contractor and any or all of its subcontractors. Applicable apprenticeship and training programs are those that have been approved and registered with the United States Department of Labor. The bidder shall list in the space below, the official name of the program sponsor holding the Certificate of Registration for all of the types of work or crafts in which the bidder is a participant and that will be performed with the bidder's forces. Types of work or craft work that will be subcontracted shall be included and listed as subcontract work. The list shall also indicate any type of work or craft job category that does not have an applicable apprenticeship or training program. **The bidder is responsible for making a complete report and shall make certain that each type of work or craft job category that will be utilized on the project as reported on the Construction Employee Workforce Projection (Form BC-1256) and returned with the bid is accounted for and listed.**

**NA - FEDERAL**

---

---

---

The requirements of this certification and disclosure are a material part of the contract, and the contractor shall require this certification provision to be included in all approved subcontracts. In order to fulfill this requirement, it shall not be necessary that an applicable program sponsor be currently taking or that it will take applications for apprenticeship, training or employment during the performance of the work of this contract.

## TO BE RETURNED WITH BID

### IV. DISCLOSURES

A. The disclosures hereinafter made by the bidder are each a material representation of fact upon which reliance is placed should the Department enter into the contract with the bidder. The Department may terminate the contract if it is later determined that the bidder rendered a false or erroneous disclosure, and the surety providing the performance bond shall be responsible for completion of the contract.

### B. Financial Interests and Conflicts of Interest

1. Section 50-35 of the Illinois Procurement Code provides that all bids of more than \$10,000 shall be accompanied by disclosure of the financial interests of the bidder. This disclosed information for the successful bidder, will be maintained as public information subject to release by request pursuant to the Freedom of Information Act.

The financial interests to be disclosed shall include ownership or distributive income share that is in excess of 5%, or an amount greater than 60% of the annual salary of the Governor, of the bidding entity or its parent entity, whichever is less, unless the contractor or bidder is a publicly traded entity subject to Federal 10K reporting, in which case it may submit its 10K disclosure in place of the prescribed disclosure. If a bidder is a privately held entity that is exempt from Federal 10K reporting, but has more than 400 shareholders, it may submit the information that Federal 10K companies are required to report, and list the names of any person or entity holding any ownership share that is in excess of 5%. The disclosure shall include the names, addresses, and dollar or proportionate share of ownership of each person making the disclosure, their instrument of ownership or beneficial relationship, and notice of any potential conflict of interest resulting from the current ownership or beneficial interest of each person making the disclosure having any of the relationships identified in Section 50-35 and on the disclosure form.

In addition, all disclosures shall indicate any other current or pending contracts, proposals, leases, or other ongoing procurement relationships the bidding entity has with any other unit of state government and shall clearly identify the unit and the contract, proposal, lease, or other relationship.

2. Disclosure Forms. Disclosure Form A is attached for use concerning the individuals meeting the above ownership or distributive share requirements. Subject individuals should be covered each by one form. In addition, a second form (Disclosure Form B) provides for the disclosure of current or pending procurement relationships with other (non-IDOT) state agencies. **The forms must be included with each bid or incorporated by reference.**

### C. Disclosure Form Instructions

#### Form A: For bidders that have previously submitted the information requested in Form A

The Department has retained the Form A disclosures submitted by all bidders responding to these requirements for the April 24, 1998 or any subsequent letting conducted by the Department. The bidder has the option of submitting the information again or the bidder may sign the following certification statement indicating that the information previously submitted by the bidder is, as of the date of signature, current and accurate. The Certification must be signed and dated by a person who is authorized to execute contracts for the bidding company. Before signing this certification, the bidder should carefully review its prior submissions to ensure the Certification is correct. If the Bidder signs the Certification, the Bidder should proceed to Form B instructions.

### CERTIFICATION STATEMENT

**I have determined that the Form A disclosure information previously submitted is current and accurate, and all forms are hereby incorporated by reference in this bid. Any necessary additional forms or amendments to previously submitted forms are attached to this bid.**

\_\_\_\_\_  
(Bidding Company)

\_\_\_\_\_  
Name of Authorized Representative (type or print)

\_\_\_\_\_  
Title of Authorized Representative (type or print)

\_\_\_\_\_  
Signature of Authorized Representative

\_\_\_\_\_  
Date

**Form A: For bidders who have NOT previously submitted the information requested in Form A**

If the bidder is a publicly traded entity subject to Federal 10K reporting, the 10K Report may be submitted to meet the requirements of Form A. If a bidder is a privately held entity that is exempt from Federal 10K reporting, but has more than 400 shareholders, it may submit the information that Federal 10K companies are required to report, and list the names of any person or entity holding any ownership share that is in excess of 5%. If a bidder is not subject to Federal 10K reporting, the bidder must determine if any individuals are required by law to complete a financial disclosure form. To do this, the bidder should answer each of the following questions. A "YES" answer indicates Form A must be completed. If the answer to each of the following questions is "NO", then the NOT APPLICABLE STATEMENT on the second page of Form A must be signed and dated by a person that is authorized to execute contracts for the bidding company. Note: These questions are for assistance only and are not required to be completed.

1. Does anyone in your organization have a direct or beneficial ownership share of greater than 5% of the bidding entity or parent entity? YES \_\_\_ NO \_\_\_
2. Does anyone in your organization have a direct or beneficial ownership share of less than 5%, but which has a value greater than \$90,420.00? YES \_\_\_ NO \_\_\_
3. Does anyone in your organization receive more than \$90,420.00 of the bidding entity's or parent entity's distributive income? (Note: Distributive income is, for these purposes, any type of distribution of profits. An annual salary is not distributive income.) YES \_\_\_ NO \_\_\_
4. Does anyone in your organization receive greater than 5% of the bidding entity's or parent entity's total distributive income, but which is less than \$90,420.00? YES \_\_\_ NO \_\_\_  
(Note: Only one set of forms needs to be completed per person per bid even if a specific individual would require a yes answer to more than one question.)

A "YES" answer to any of these questions requires the completion of Form A. The bidder must determine each individual in the bidding entity or the bidding entity's parent company that would cause the questions to be answered "Yes". Each form must be signed and dated by a person that is authorized to execute contracts for your organization. **Photocopied or stamped signatures are not acceptable.** The person signing can be, but does not have to be, the person for which the form is being completed. The bidder is responsible for the accuracy of any information provided.

If the answer to each of the above questions is "NO", then the NOT APPLICABLE STATEMENT on page 2 of Form A must be signed and dated by a person that is authorized to execute contracts for your company.

**Form B: Identifying Other Contracts & Procurement Related Information** Disclosure Form B must be completed for each bid submitted by the bidding entity. It must be signed by an individual who is authorized to execute contracts for the bidding entity. *Note: Signing the NOT APPLICABLE STATEMENT on Form A does not allow the bidder to ignore Form B. Form B must be completed, signed and dated or the bidder may be considered nonresponsive and the bid will not be accepted.*

The Bidder shall identify, by checking Yes or No on Form B, whether it has any pending contracts (including leases), bids, proposals, or other ongoing procurement relationship with any other (non-IDOT) State of Illinois agency. If "No" is checked, the bidder only needs to complete the signature box on the bottom of Form B. If "Yes" is checked, the bidder must do one of the following:

Option I: If the bidder did not submit an Affidavit of Availability to obtain authorization to bid, the bidder must list all non-IDOT State of Illinois agency pending contracts, leases, bids, proposals, and other ongoing procurement relationships. These items may be listed on Form B or on an attached sheet(s). Do not include IDOT contracts. Contracts with cities, counties, villages, etc. are not considered State of Illinois agency contracts and are not to be included. Contracts with other State of Illinois agencies such as the Department of Natural Resources or the Capital Development Board must be included. Bidders who submit Affidavits of Availability are suggested to use Option II.

Option II: If the bidder is required and has submitted an Affidavit of Availability in order to obtain authorization to bid, the bidder may write or type "See Affidavit of Availability" which indicates that the Affidavit of Availability is incorporated by reference and includes all non-IDOT State of Illinois agency pending contracts, leases, bids, proposals, and other ongoing procurement relationships. For any contracts that are not covered by the Affidavit of Availability, the bidder must identify them on Form B or on an attached sheet(s). These might be such things as leases.

**D. Bidders Submitting More Than One Bid**

Bidders submitting multiple bids may submit one set of forms consisting of all required Form A disclosures and one Form B for use with all bids. Please indicate in the space provided below the bid item that contains the original disclosure forms and the bid items which incorporate the forms by reference.

- The bid submitted for letting item \_\_\_\_\_ contains the Form A disclosures or Certification Statement and the Form B disclosures. The following letting items incorporate the said forms by reference:

---



---

RETURN WITH BID/OFFER

**ILLINOIS DEPARTMENT  
OF TRANSPORTATION**

**Form A  
Financial Information &  
Potential Conflicts of Interest  
Disclosure**

Contractor Name		
Legal Address		
City, State, Zip		
Telephone Number	Email Address	Fax Number (if available)

Disclosure of the information contained in this Form is required by the Section 50-35 of the Illinois Procurement Code (30 ILCS 500). Vendors desiring to enter into a contract with the State of Illinois must disclose the financial information and potential conflict of interest information as specified in this Disclosure Form. This information shall become part of the publicly available contract file. This Form A must be completed for bids in excess of \$10,000, and for all open-ended contracts. **A publicly traded company may submit a 10K disclosure (or equivalent if applicable) in satisfaction of the requirements set forth in Form A. See Disclosure Form Instructions.**

**DISCLOSURE OF FINANCIAL INFORMATION**

**1. Disclosure of Financial Information.** The individual named below has an interest in the BIDDER (or its parent) in terms of ownership or distributive income share in excess of 5%, or an interest which has a value of more than \$90,420.00 (60% of the Governor's salary as of 7/1/01). **(Make copies of this form as necessary and attach a separate Disclosure Form A for each individual meeting these requirements)**

**FOR INDIVIDUAL (type or print information)**

**NAME:** \_\_\_\_\_

**ADDRESS** \_\_\_\_\_

**Type of ownership/distributable income share:**

stock \_\_\_\_\_ sole proprietorship \_\_\_\_\_ Partnership \_\_\_\_\_ other: (explain on separate sheet):  
% or \$ value of ownership/distributable income share: \_\_\_\_\_

**2. Disclosure of Potential Conflicts of Interest.** Check "Yes" or "No" to indicate which, if any, of the following potential conflict of interest relationships apply. If the answer to any question is "Yes", please attach additional pages and describe.

(a) State employment, currently or in the previous 3 years, including contractual employment of services.

Yes \_\_\_ No \_\_\_

If your answer is yes, please answer each of the following questions.

- Are you currently an officer or employee of either the Capitol Development Board or the Illinois Toll Highway Authority? Yes \_\_\_ No \_\_\_
- Are you currently appointed to or employed by any agency of the State of Illinois? If you are currently appointed to or employed by any agency of the State of Illinois, and your annual salary exceeds \$90,420.00, (60% of the Governor's salary as of 7/1/01) provide the name the State agency for which you are employed and your annual salary. \_\_\_\_\_

## RETURN WITH BID/OFFER

3. If you are currently appointed to or employed by any agency of the State of Illinois, and your annual salary exceeds \$90,420.00, (60% of the Governor's salary as of 7/1/01) are you entitled to receive (i) more than 7 1/2% of the total distributable income of your firm, partnership, association or corporation, or (ii) an amount in excess of the salary of the Governor? Yes \_\_\_ No \_\_\_
4. If you are currently appointed to or employed by any agency of the State of Illinois, and your annual salary exceeds \$90,420.00, (60% of the Governor's salary as of 7/1/01) are you and your spouse or minor children entitled to receive (i) more than 15% in aggregate of the total distributable income of your firm, partnership, association or corporation, or (ii) an amount in excess of 2 times the salary of the Governor? Yes \_\_\_ No \_\_\_

---

(b) State employment of spouse, father, mother, son, or daughter, including contractual employment for services in the previous 2 years.

Yes \_\_\_ No \_\_\_

If your answer is yes, please answer each of the following questions.

1. Is your spouse or any minor children currently an officer or employee of the Capitol Development Board or the Illinois Toll Highway Authority? Yes \_\_\_ No \_\_\_
2. Is your spouse or any minor children currently appointed to or employed by any agency of the State of Illinois? If your spouse or minor children is/are currently appointed to or employed by any agency of the State of Illinois, and his/her annual salary exceeds \$90,420.00, (60% of the Governor's salary as of 7/1/01) provide the name of the spouse and/or minor children, the name of the State agency for which he/she is employed and his/her annual salary. \_\_\_\_\_
- 
3. If your spouse or any minor children is/are currently appointed to or employed by any agency of the State of Illinois, and his/her annual salary exceeds \$90,420.00, (60% of the salary of the Governor as of 7/1/01) are you entitled to receive (i) more than 7 1/2% of the total distributable income of your firm, partnership, association or corporation, or (ii) an amount in excess of the salary of the Governor? Yes \_\_\_ No \_\_\_
4. If your spouse or any minor children are currently appointed to or employed by any agency of the State of Illinois, and his/her annual salary exceeds \$90,420.00, (60% of the Governor's salary as of 7/1/01) are you and your spouse or any minor children entitled to receive (i) more than 15% in the aggregate of the total distributable income from your firm, partnership, association or corporation, or (ii) an amount in excess of 2 times the salary of the Governor? Yes \_\_\_ No \_\_\_

---

(c) Elective status; the holding of elective office of the State of Illinois, the government of the United States, any unit of local government authorized by the Constitution of the State of Illinois or the statutes of the State of Illinois currently or in the previous 3 years. Yes \_\_\_ No \_\_\_

---

(d) Relationship to anyone holding elective office currently or in the previous 2 years; spouse, father, mother, son, or daughter. Yes \_\_\_ No \_\_\_

---

(e) Appointive office; the holding of any appointive government office of the State of Illinois, the United State of America, or any unit of local government authorized by the Constitution of the State of Illinois or the statutes of the State of Illinois, which office entitles the holder to compensation in excess of the expenses incurred in the discharge of that office currently or in the previous 3 years. Yes \_\_\_ No \_\_\_

---

(f) Relationship to anyone holding appointive office currently or in the previous 2 years; spouse, father, mother, son, or daughter. Yes \_\_\_ No \_\_\_

---

(g) Employment, currently or in the previous 3 years, as or by any registered lobbyist of the State government. Yes \_\_\_ No \_\_\_

---

**RETURN WITH BID/OFFER**

(h) Relationship to anyone who is or was a registered lobbyist in the previous 2 years; spouse, father, mother, son, or daughter. Yes \_\_\_ No \_\_\_

(i) Compensated employment, currently or in the previous 3 years, by any registered election or reelection committee registered with the Secretary of State or any county clerk of the State of Illinois, or any political action committee registered with either the Secretary of State or the Federal Board of Elections. Yes \_\_\_ No \_\_\_

(j) Relationship to anyone; spouse, father, mother, son, or daughter; who was a compensated employee in the last 2 years by any registered election or re-election committee registered with the Secretary of State or any county clerk of the State of Illinois, or any political action committee registered with either the Secretary of State or the Federal Board of Elections. Yes \_\_\_ No \_\_\_

**APPLICABLE STATEMENT**

**This Disclosure Form A is submitted on behalf of the INDIVIDUAL named on previous page.**

Completed by: \_\_\_\_\_  
Name of Authorized Representative (type or print)

Completed by: \_\_\_\_\_  
Title of Authorized Representative (type or print)

Completed by: \_\_\_\_\_ Date \_\_\_\_\_  
Signature of Individual or Authorized Representative

**NOT APPLICABLE STATEMENT**

**I have determined that no individuals associated with this organization meet the criteria that would require the completion of this Form A.**

**This Disclosure Form A is submitted on behalf of the CONTRACTOR listed on the previous page.**

\_\_\_\_\_  
Name of Authorized Representative (type or print)

\_\_\_\_\_  
Title of Authorized Representative (type or print)

\_\_\_\_\_  
Signature of Authorized Representative Date \_\_\_\_\_



RETURN WITH BID/OFFER

**ILLINOIS DEPARTMENT  
OF TRANSPORTATION**

**Form B  
Other Contracts &  
Procurement Related Information  
Disclosure**

Contractor Name		
Legal Address		
City, State, Zip		
Telephone Number	Email Address	Fax Number (if available)

Disclosure of the information contained in this Form is required by the Section 50-35 of the Illinois Procurement Act (30 ILCS 500). This information shall become part of the publicly available contract file. This Form B must be completed for bids in excess of \$10,000, and for all open-ended contracts.

**DISCLOSURE OF OTHER CONTRACTS AND PROCUREMENT RELATED INFORMATION**

**1. Identifying Other Contracts & Procurement Related Information.** The BIDDER shall identify whether it has any pending contracts (including leases), bids, proposals, or other ongoing procurement relationship with any other State of Illinois agency: Yes \_\_\_ No \_\_\_

If "No" is checked, the bidder only needs to complete the signature box on the bottom of this page.

**2. If "Yes" is checked.** Identify each such relationship by showing State of Illinois agency name and other descriptive information such as bid or project number (attach additional pages as necessary). SEE DISCLOSURE FORM INSTRUCTIONS:

**THE FOLLOWING STATEMENT MUST BE SIGNED**

_____	
Name of Authorized Representative (type or print)	
_____	
Title of Authorized Representative (type or print)	
_____	_____
Signature of Authorized Representative	Date

## **RETURN WITH BID**

### **SPECIAL NOTICE TO CONTRACTORS**

The following requirements of the Illinois Department of Human Rights' Rules and Regulations are applicable to bidders on all construction contracts advertised by the Illinois Department of Transportation:

#### **CONSTRUCTION EMPLOYEE UTILIZATION PROJECTION**

- (a) All bidders on construction contracts shall complete and submit, along with and as part of their bids, a Bidder's Employee Utilization Form (Form BC-1256) setting forth a projection and breakdown of the total workforce intended to be hired and/or allocated to such contract work by the bidder including a projection of minority and female employee utilization in all job classifications on the contract project.
- (b) The Department of Transportation shall review the Employee Utilization Form, and workforce projections contained therein, of the contract awardee to determine if such projections reflect an underutilization of minority persons and/or women in any job classification in accordance with the Equal Employment Opportunity Clause and Section 7.2 of the Illinois Department of Human Rights' Rules and Regulations for Public Contracts adopted as amended on September 17, 1980. If it is determined that the contract awardee's projections reflect an underutilization of minority persons and/or women in any job classification, it shall be advised in writing of the manner in which it is underutilizing and such awardee shall be considered to be in breach of the contract unless, prior to commencement of work on the contract project, it submits revised satisfactory projections or an acceptable written affirmative action plan to correct such underutilization including a specific timetable geared to the completion stages of the contract.
- (c) The Department of Transportation shall provide to the Department of Human Rights a copy of the contract awardee's Employee Utilization Form, a copy of any required written affirmative action plan, and any written correspondence related thereto. The Department of Human Rights may review and revise any action taken by the Department of Transportation with respect to these requirements.



**RETURN WITH BID**

**Contract No. 97251  
MADISON County  
Section 02-00180-01-PV (Granite City)  
Project M-5011(178)  
Route FAU 9089 (20th Street)  
District 8 Construction Funds**

**PART II. WORKFORCE PROJECTION - continued**

- B. Included in "Total Employees" under Table A is the total number of **new hires** that would be employed in the event the undersigned bidder is awarded this contract.

The undersigned bidder projects that: (number) \_\_\_\_\_ new hires would be recruited from the area in which the contract project is located; and/or (number) \_\_\_\_\_ new hires would be recruited from the area in which the bidder's principal office or base of operation is located.

- C. Included in "Total Employees" under Table A is a projection of numbers of persons to be employed directly by the undersigned bidder as well as a projection of numbers of persons to be employed by subcontractors.

The undersigned bidder estimates that (number) \_\_\_\_\_ persons will be directly employed by the prime contractor and that (number) \_\_\_\_\_ persons will be employed by subcontractors.

**PART III. AFFIRMATIVE ACTION PLAN**

- A. The undersigned bidder understands and agrees that in the event the foregoing minority and female employee utilization projection included under **PART II** is determined to be an underutilization of minority persons or women in any job category, and in the event that the undersigned bidder is awarded this contract, he/she will, prior to commencement of work, develop and submit a written Affirmative Action Plan including a specific timetable (geared to the completion stages of the contract) whereby deficiencies in minority and/or female employee utilization are corrected. Such Affirmative Action Plan will be subject to approval by the contracting agency and the **Department of Human Rights**.
- B. The undersigned bidder understands and agrees that the minority and female employee utilization projection submitted herein, and the goals and timetable included under an Affirmative Action Plan if required, are deemed to be part of the contract specifications.

Company \_\_\_\_\_ Telephone Number \_\_\_\_\_

Address \_\_\_\_\_

**NOTICE REGARDING SIGNATURE**

The Bidder's signature on the Proposal Signature Sheet will constitute the signing of this form. The following signature block needs to be completed only if revisions are required.

Signature: \_\_\_\_\_ Title: \_\_\_\_\_ Date: \_\_\_\_\_

Instructions: All tables must include subcontractor personnel in addition to prime contractor personnel.

Table A - Include both the number of employees that would be hired to perform the contract work and the total number currently employed (Table B) that will be allocated to contract work, and include all apprentices and on-the-job trainees. The "Total Employees" column should include all employees including all minorities, apprentices and on-the-job trainees to be employed on the contract work.

Table B - Include all employees currently employed that will be allocated to the contract work including any apprentices and on-the-job trainees currently employed.

Table C - Indicate the racial breakdown of the total apprentices and on-the-job trainees shown in Table A.

**RETURN WITH BID**

**ADDITIONAL FEDERAL REQUIREMENTS**

In addition to the Required Contract Provisions for Federal-Aid Construction Contracts (FHWA 1273), all bidders make the following certifications.

- A. By the execution of this proposal, the signing bidder certifies that the bidding entity has not, either directly or indirectly, entered into any agreement, participated in any collusion, or otherwise taken any action, in restraint of free competitive bidding in connection with the submitted bid. This statement made by the undersigned bidder is true and correct under penalty of perjury under the laws of the United States.
- B. CERTIFICATION, EQUAL EMPLOYMENT OPPORTUNITY:
1. Have you participated in any previous contracts or subcontracts subject to the equal opportunity clause. YES \_\_\_\_\_ NO \_\_\_\_\_
  2. If answer to #1 is yes, have you filed with the Joint Reporting Committee, the Director of OFCC, any Federal agency, or the former President's Committee on Equal Employment Opportunity, all reports due under the applicable filing requirements of those organizations? YES \_\_\_\_\_ NO \_\_\_\_\_

**RETURN WITH BID**

**Contract No. 97251  
MADISON County  
Section 02-00180-01-PV (Granite City)  
Project M-5011(178)  
Route FAU 9089 (20th Street)  
District 8 Construction Funds**

PROPOSAL SIGNATURE SHEET

The undersigned bidder hereby makes and submits this bid on the subject Proposal, thereby assuring the Department that all requirements of the Invitation for Bids and rules of the Department have been met, that there is no misunderstanding of the requirements of paragraph 3 of this Proposal, and that the contract will be executed in accordance with the rules of the Department if an award is made on this bid.

(IF AN INDIVIDUAL) Firm Name \_\_\_\_\_  
Signature of Owner \_\_\_\_\_  
Business Address \_\_\_\_\_  
\_\_\_\_\_

(IF A CO-PARTNERSHIP) Firm Name \_\_\_\_\_  
By \_\_\_\_\_  
Business Address \_\_\_\_\_  
Name and Address of All Members of the Firm: \_\_\_\_\_  
\_\_\_\_\_

(IF A CORPORATION) Corporate Name \_\_\_\_\_  
By \_\_\_\_\_  
Signature of Authorized Representative \_\_\_\_\_  
Typed or printed name and title of Authorized Representative \_\_\_\_\_

(IF A JOINT VENTURE, USE THIS SECTION FOR THE MANAGING PARTY AND THE SECOND PARTY SHOULD SIGN BELOW) Attest \_\_\_\_\_  
Signature \_\_\_\_\_  
Business Address \_\_\_\_\_

(IF A JOINT VENTURE) Corporate Name \_\_\_\_\_  
By \_\_\_\_\_  
Signature of Authorized Representative \_\_\_\_\_  
Typed or printed name and title of Authorized Representative \_\_\_\_\_

Attest \_\_\_\_\_  
Signature \_\_\_\_\_  
Business Address \_\_\_\_\_

If more than two parties are in the joint venture, please attach an additional signature sheet.

RETURN WITH BID



Division of Highways
Proposal Bid Bond
(Effective November 1, 1992)

Item No.
Letting Date

KNOW ALL MEN BY THESE PRESENTS, That We

as PRINCIPAL, and

held jointly, severally and firmly bound unto the STATE OF ILLINOIS in the penal sum of 5 percent of the total bid price, or for the amount specified in Article 102.09 of the "Standard Specifications for Road and Bridge Construction" in effect on the date of invitation for bids, whichever is the lesser sum, well and truly to be paid unto said STATE OF ILLINOIS, for the payment of which we bind ourselves, our heirs, executors, administrators, successors and assigns.

THE CONDITION OF THE FOREGOING OBLIGATION IS SUCH, That Whereas, the PRINCIPAL has submitted a bid proposal to the STATE OF ILLINOIS, acting through the Department of Transportation, for the improvement designated by the Transportation Bulletin Item Number and Letting Date indicated above.

NOW, THEREFORE, if the Department shall accept the bid proposal of the PRINCIPAL; and if the PRINCIPAL shall, within the time and as specified in the bidding and contract documents, submit a DBE Utilization Plan that is accepted and approved by the Department; and if, after award by the Department, the PRINCIPAL shall enter into a contract in accordance with the terms of the bidding and contract documents including evidence of the required insurance coverages and providing such bond as specified with good and sufficient surety for the faithful performance of such contract and for the prompt payment of labor and material furnished in the prosecution thereof; or if, in the event of the failure of the PRINCIPAL to make the required DBE submission or to enter into such contract and to give the specified bond, the PRINCIPAL pays to the Department the difference not to exceed the penalty hereof between the amount specified in the bid proposal and such larger amount for which the Department may contract with another party to perform the work covered by said bid proposal, then this obligation shall be null and void, otherwise, it shall remain in full force and effect.

IN THE EVENT the Department determines the PRINCIPAL has failed to comply with any requirement as set forth in the preceding paragraph, then Surety shall pay the penal sum to the Department within fifteen (15) days of written demand therefor. If Surety does not make full payment within such period of time, the Department may bring an action to collect the amount owed. Surety is liable to the Department for all its expenses, including attorney's fees, incurred in any litigation in which it prevails either in whole or in part.

In TESTIMONY WHEREOF, the said PRINCIPAL and the said SURETY have caused this instrument to be signed by their respective officers this day of A.D.,

PRINCIPAL SURETY
(Company Name)
By: (Signature & Title) By: (Signature of Attorney-in-Fact)

Notary Certification for Principal and Surety

STATE OF ILLINOIS,
COUNTY OF

I, a Notary Public in and for said County, do hereby certify that and

(Insert names of individuals signing on behalf of PRINCIPAL & SURETY)

who are each personally known to me to be the same persons whose names are subscribed to the foregoing instrument on behalf of PRINCIPAL and SURETY, appeared before me this day in person and acknowledged respectively, that they signed and delivered said instrument as their free and voluntary act for the uses and purposes therein set forth.

Given under my hand and notarial seal this day of, A.D.

My commission expires Notary Public

In lieu of completing the above section of the Proposal Bid Form, the Principal may file an Electronic Bid Bond. By signing below the Principal is ensuring the identified electronic bid bond has been executed and the Principal and Surety are firmly bound unto the State of Illinois under the conditions of the bid bond as shown above.

Electronic Bid Bond ID# Company/Bidder Name Signature and Title

# PROPOSAL ENVELOPE



## PROPOSALS

for construction work advertised for bids by the  
Illinois Department of Transportation

Item No.	Item No.	Item No.

Submitted By:

Name:
Address:
Phone No.

Bidders should use an IDOT proposal envelope or affix this form to the front of a 10" x 13" envelope for the submittal of bids. If proposals are mailed, they should be enclosed in a second or outer envelope addressed to:

Engineer of Design and Environment - Room 326  
Illinois Department of Transportation  
2300 South Dirksen Parkway  
Springfield, Illinois 62764

### **NOTICE**

**Individual bids, including Bid Bond and/or supplemental information if required, should be securely stapled.**



# CONTRACTOR OFFICE COPY OF CONTRACT SPECIFICATIONS

## NOTICE

None of the following material needs to be returned with the bid package unless the special provisions require documentation and/or other information to be submitted.

**Contract No. 97251  
MADISON County  
Section 02-00180-01-PV (Granite City)  
Project M-5011(178)  
Route FAU 9089 (20th Street)  
District 8 Construction Funds**



**Illinois Department of Transportation**



## NOTICE TO BIDDERS

- 1. TIME AND PLACE OF OPENING BIDS.** Sealed proposals for the improvement described herein will be received by the Department of Transportation at the Harry R. Hanley Building, 2300 South Dirksen Parkway, in Springfield, Illinois until 10:00 o'clock a.m., June 17, 2005. All bids will be gathered, sorted, publicly opened and read in the auditorium at the Department of Transportation's Harry R. Hanley Building shortly after the 10:00 a.m. cut off time.
- 2. DESCRIPTION OF WORK.** The proposed improvement is identified and advertised for bids in the Invitation for Bids as:

**Contract No. 97251  
MADISON County  
Section 02-00180-01-PV (Granite City)  
Project M-5011(178)  
Route FAU 9089 (20th Street)  
District 8 Construction Funds**

**Improvement consists of 0.08 miles of pavement removal, PCC pavement 10", curb and gutter, sidewalks, traffic signal upgrades and storm sewers along 20th Street from the intersection of Madison Avenue and 20th Street to the intersection of Iowa Street and 20th Street in Granite City.**

- 3. INSTRUCTIONS TO BIDDERS.** (a) This Notice, the invitation for bids, proposal and letter of award shall, together with all other documents in accordance with Article 101.09 of the Standard Specifications for Road and Bridge Construction, become part of the contract. Bidders are cautioned to read and examine carefully all documents, to make all required inspections, and to inquire or seek explanation of the same prior to submission of a bid.  
  
(b) State law, and, if the work is to be paid wholly or in part with Federal-aid funds, Federal law requires the bidder to make various certifications as a part of the proposal and contract. By execution and submission of the proposal, the bidder makes the certification contained therein. A false or fraudulent certification shall, in addition to all other remedies provided by law, be a breach of contract and may result in termination of the contract.
- 4. AWARD CRITERIA AND REJECTION OF BIDS.** This contract will be awarded to the lowest responsive and responsible bidder considering conformity with the terms and conditions established by the Department in the rules, Invitation for Bids and contract documents. The issuance of plans and proposal forms for bidding based upon a prequalification rating shall not be the sole determinant of responsibility. The Department reserves the right to determine responsibility at the time of award, to reject any or all proposals, to readvertise the proposed improvement, and to waive technicalities.

By Order of the  
Illinois Department of Transportation

Timothy W. Martin, Secretary

BD 351 (Rev. 01/2003)

INDEX  
FOR  
SUPPLEMENTAL SPECIFICATIONS  
AND RECURRING SPECIAL PROVISIONS  
Adopted March 1, 2005

This index contains a listing of SUPPLEMENTAL SPECIFICATIONS and frequently used RECURRING SPECIAL PROVISIONS and LOCAL ROADS AND STREETS RECURRING SPECIAL PROVISIONS.

ERRATA Standard Specifications for Road and Bridge Construction (Adopted 1-1-02) (Revised 3-1-05)

SUPPLEMENTAL SPECIFICATIONS

<u>Std. Spec. Sec.</u>	<u>Page No.</u>
101 Definition of Terms .....	1
105 Control of Work .....	2
205 Embankment .....	3
251 Mulch .....	4
281 Riprap .....	5
282 Filter Fabric for Use With Riprap .....	8
285 Concrete Revetment Mats .....	10
311 Granular Subbase .....	14
351 Aggregate Base Course .....	15
440 Removal of Existing Pavement and Appurtenances .....	16
442 Pavement Patching .....	17
449 Removal and Replacement of Preformed Elastomeric Compression Joint Seal .....	18
481 Aggregate Shoulders .....	19
501 Removal of Existing Structures .....	20
503 Concrete Structures .....	21
505 Steel Structures .....	22
506 Cleaning and Painting Metal Structures .....	25
508 Reinforcement Bars .....	26
512 Piling .....	27
540 Box Culverts .....	28
589 Elastic Joint Sealer .....	30
602 Catch Basin, Manhole, Inlet, Drainage Structures and Valve Vault Construction, Adjustment and Reconstruction .....	31
603 Adjusting Frames and Grates of Drainage and Utility Structures .....	32
610 Shoulder Inlets with Curb .....	33
665 Woven Wire Fence .....	34
669 Removal and Disposal of Regulated Substances .....	35
671 Mobilization .....	36
702 Work Zone Traffic Control Devices .....	37
1003 Fine Aggregates .....	38
1004 Coarse Aggregate .....	39
1005 Stone, Concrete Blocks and Broken Concrete for Erosion Protection, Sediment Control and Rockfill .....	42
1006 Metals .....	46
1007 Timber and Preservative Treatment .....	49
1012 Hydrated Lime .....	50
1020 Portland Cement Concrete .....	51
1021 Concrete Admixtures .....	58
1022 Concrete Curing Materials .....	59
1024 Nonshrink Grout .....	61
1041 Brick .....	63
1043 Precast Reinforced Concrete Manhole Sections and Adjusting Rings .....	64
1056 Preformed Flexible Gaskets and Mastic Joint Sealer for Sewer and Culvert Pipe .....	66
1059 Elastic Joint Sealers .....	67
1060 Waterproofing Materials .....	68
1069 Pole and Tower .....	69
1070 Foundation and Breakaway Devices .....	70
1077 Post and Foundation .....	72
1080 Fabric Materials .....	73
1081 Materials For Planting .....	76
1083 Elastomeric Bearings .....	77
1094 Overhead Sign Structures .....	78
1103 Portland Cement Concrete Equipment .....	79

**RECURRING SPECIAL PROVISIONS**

The following RECURRING SPECIAL PROVISIONS and RECURRING LOCAL ROADS AND STREETS SPECIAL PROVISIONS indicated by an "X" are applicable to this contract and are included by reference:

<u>CHECK SHEET #</u>	<u>PAGE NO.</u>
1 X State Required Contract Provisions All Federal-aid Construction Contracts (Eff. 2-1-69) (Rev. 10-1-83)...	80
2 X Subletting of Contracts (Federal-aid Contracts) (Eff. 1-1-88) (Rev. 5-1-93) .....	82
3 X EEO (Eff. 7-21-78) (Rev. 11-18-80) .....	83
4 Specific Equal Employment Opportunity Responsibilities NonFederal-aid Contracts (Eff. 3-20-69) (Rev. 1-1-94) .....	94
5 Required Provisions - State Contracts (Eff. 4-1-65) (Rev. 4-1-93).....	100
6 Reserved.....	105
7 Asphalt Quantities and Cost Reviews (Eff. 7-1-88).....	106
8 National Pollutant Discharge Elimination System Permit (Eff. 7-1-94) (Rev. 1-1-03) .....	107
9 Haul Road Stream Crossings, Other Temporary Stream Crossings and In-Stream Work Pads (Eff. 1-2-92) (Rev. 1-1-98) .....	108
10 Construction Layout Stakes Except for Bridges (Eff. 1-1-99) (Rev. 1-1-02).....	109
11 Construction Layout Stakes (Eff. 5-1-93) (Rev. 1-1-02).....	112
12 Use of Geotextile Fabric for Railroad Crossing (Eff. 1-1-95) (Rev. 1-1-97).....	115
13 Asphaltic Emulsion Slurry Seal and Fibrated Asphaltic Emulsion Slurry Seal (Eff. 8-1-89) (Rev. 2-1-97)...	117
14 Bituminous Surface Treatments Half-Smart (Eff. 7-1-93) (Rev. 1-1-97) .....	123
15 X Quality Control/Quality Assurance of Bituminous Concrete Mixtures (Eff. 1-1-00) (Rev. 3-1-05) .....	129
16 Subsealing of Concrete Pavements (Eff. 11-1-84) (Rev. 2-1-95) .....	148
17 Bituminous Surface Removal (Cold Milling) (Eff. 11-1-87) (Rev. 10-15-97).....	152
18 Resurfacing of Milled Surfaces (Eff. 10-1-95) .....	154
19 PCC Partial Depth Bituminous Patching (Eff. 1-1-98).....	155
20 Patching with Bituminous Overlay Removal (Eff. 10-1-95) (Rev. 7-1-99) .....	157
21 Reserved.....	159
22 Protective Shield System (Eff. 4-1-95) (Rev. 1-1-03).....	160
23 Polymer Concrete (Eff. 8-1-95) (Rev. 3-1-05) .....	162
24 Controlled Low-Strength Material (CLSM) (Eff. 1-1-90) (Rev. 3-1-05) .....	164
25 Pipe Underdrains (Eff. 9-9-87) (Rev. 1-1-98).....	169
26 Guardrail and Barrier Wall Delineation (Eff. 12-15-93) (Rev. 1-1-97).....	170
27 Bicycle Racks (Eff. 4-1-94) (Rev. 1-1-97) .....	175
28 Reserved.....	177
29 Reserved.....	178
30 Reserved.....	179
31 Night Time Inspection of Roadway Lighting (Eff. 5-1-96).....	180
32 Reserved.....	181
33 English Substitution of Metric Bolts (Eff. 7-1-96).....	182
34 English Substitution of Metric Reinforcement Bars (Eff. 4-1-96) (Rev. 1-1-03) .....	183
35 Polymer Modified Emulsified Asphalt (Eff. 5-15-89) (Rev. 1-1-04) .....	185
36 Corrosion Inhibitor (Eff. 3-1-80) (Rev. 7-1-99) .....	187
37 Quality Control of Concrete Mixtures at the Plant-Single A (Eff. 8-1-00) (Rev. 1-1-04) .....	188
38 Quality Control of Concrete Mixtures at the Plant-Double A (Eff. 8-1-00) (Rev. 1-1-04).....	194
39 Quality Control/Quality Assurance of Concrete Mixtures (Eff. 4-1-92) (Rev. 3-1-05).....	202
40 Traffic Barrier Terminal Type 1, Special (Eff. 8-1-94) (Rev. 1-1-03) .....	215
41 Reserved.....	216
42 X Segregation Control of Bituminous Concrete (Eff. 7-15-97).....	217
43 Reserved.....	220

**LOCAL ROADS AND STREETS RECURRING SPECIAL PROVISIONS**

	<u>PAGE NO.</u>
LRS 1 <input type="checkbox"/> Cooperation With Utilities (Eff. 1-1-99) (Rev. 1-1-02) .....	222
LRS 2 <input type="checkbox"/> Furnished Excavation (Eff. 1-1-99) (Rev. 1-1-02) .....	224
LRS 3 <input checked="" type="checkbox"/> Construction Zone Traffic Control (Eff. 1-1-99) .....	225
LRS 4 <input checked="" type="checkbox"/> Flaggers in Work Zones (Eff. 1-1-99) .....	226
LRS 5 <input type="checkbox"/> Reserved .....	227
LRS 6 <input type="checkbox"/> Bidding Requirements and Conditions for Contract Proposals (Eff. 1-1-02) .....	228
LRS 7 <input type="checkbox"/> Bidding Requirements and Conditions for Material Proposals (Eff. 1-1-03) .....	234
LRS 8 <input type="checkbox"/> Failure to Complete the Work on Time (Eff. 1-1-99) .....	240
LRS 9 <input type="checkbox"/> Bituminous Surface Treatments (Eff. 1-1-99) .....	241
LRS 10 <input type="checkbox"/> Reflective Sheeting Type C (Eff. 1-1-99) (Rev. 1-1-02) .....	242
LRS 11 <input type="checkbox"/> Employment Practices (Eff. 1-1-99) .....	243
LRS 12 <input type="checkbox"/> Wages of Employees on Public Works (Eff. 1-1-99) .....	245
LRS 13 <input type="checkbox"/> Selection of Labor (Eff. 1-1-99) .....	246

## INDEX TO SPECIAL PROVISIONS

<u>SHEET(S)</u>	<u>SPECIAL PROVISIONS</u>
1	LOCATION OF PROJECT
1	DESCRIPTION OF PROJECT
1	TRAFFIC CONTROL PLAN
2	TRAFFIC CONTROL AND PROTECTION
3	SIGN REMOVAL AND REPLACEMENT
4	BARRICADES OR DRUMS
4	ACCESS TO ENTRANCES
4	AGGREGATE FOR TEMPORARY ACCESS
5	DISPOSAL OF SURPLUS MATERIAL
5	JOINT UTILITY LOCATING INFORMATION FOR EXCAVATORS (J.U.L.I.E.)
5	COOPERATION WITH UTILITIES
6	CONSTRUCTION EASEMENTS AND EXCESS RIGHT-OF-WAY
6	CONNECTING TO EXISTING MANHOLE
7	INCIDENTAL BITUMINOUS SURFACING, SUPERPAVE
7	TRAFFIC SIGNAL TURN-ON AND FINAL INSPECTION
7	VEHICLE DETECTOR LOOP INSTALLATION
8	LIGHT EMITTING DIODE (LED) SIGNAL FACE RETROFIT (BALL INDICATIONS)
16	LIGHT EMITTING DIODE (LED) SIGNAL FACE RETROFIT (ARROW INDICATIONS)
25	LIGHT EMITTING DIODE (LED) SIGNAL HEAD
27	REMOVING EXISTING TRAFFIC SIGNAL EQUIPMENT
27	REMOVE EXISTING CONCRETE FOUNDATIONS
28	ADA PEDESTRIAN PUSH-BUTTON
28	GEOMETRICALLY PROGRAMMED LOUVER
28	MODIFY EXISTING CONTROLLER
29	INTERSECTION TRAFFIC CONTROL DURING CONSTRUCTION
29	CONCRETE STAIRS REMOVAL
30	CONCRETE STAIRS
30	PROTECTION OF EXISTING RETAINING WALL
30	EMERGENCY SERVICES COORDINATION

30	SEEDING CLASS 2
31	STATUS OF UTILITIES TO BE ADJUSTED

INDEX LOCAL ROADS AND STREETS SPECIAL PROVISIONS

<u>LR#</u>	<u>TITLE</u>	<u>PAGE</u>
SD 16	"Slab Movement Detection Device" (Eff. 11-1-84).....	
SD 17	"Required Cold Milled Surface Texture" (Eff. 11-1-87).....	
107-1	"Nationwide Permit No. 14" (Eff. 2-1-04) (Rev. 3-1-05). Developed by the Bureau of Local Roads and Streets..... to outline the necessary requirements to comply with No. 14 permits.	
107-2	"Railroad Protective Liability Insurance for Local Lettings" (Eff. 3-1-05). Developed by the Bureau of Local Roads & Streets to require insurance policies to be submitted to the letting agency rather than the department.	
108	"Combination Bids (Eff. 1-1-94)(Rev. 3-1-05). Developed by the Bureau of Local Roads & Streets to allow ..... the revision of working days and calendar days. Revised to incorporate applicable portions of deleted Sections 102 & 103	
109	"Contract Claims" (Eff. 1-1-02) (Rev. 5-1-02). Developed by the Bureau of Local Roads..... and Streets to assist local agencies in handling contract claims.	
212	"Shaping Roadway" (Eff. 8-1-69) (Rev. 1-1-02).....	
302	<b>Rescinded</b> .....	
355-1	"Asphalt Stabilized Base Course, Road Mix or Traveling Plant Mix" (Eff. 10-1-73)(Rev. 1-1-02).....	
355-2	"Asphalt Stabilized Base Course, Plant Mix" (Eff. 2-20-63)(Rev. 1-1-02) .....	
355-3	"Bituminous Aggregate Mixture Base Course" (6-27-66)(Rev. 1-1-02). Developed by the..... Bureau of Materials and Physical Research and the Bureau of Local Roads and Streets to construct a stabilized base course with paving grade asphalt.	
400	"Penetrating Emulsified Prime" (Eff. 4-1-84)(Rev. 1-1-02).....	
402	"Salt Stabilized Surface Course" (Eff. 2-20-63)(Rev. 1-1-02).....	
403-1	"Penetrating Emulsified Asphalt" (Eff. 1-1-94)(Rev. 1-1-02). Developed for bituminous..... surface treatments on roads that require flexibility and penetration due to low traffic volume.	
403-2	Bituminous Hot Mix Sand Seal Coat" (Eff. 8-1-69)(Rev. 1-1-02).....	
420	"PCC Pavement (Special)" (Eff. 5-12-64)(Rev. 1-1-02). Developed by the Bureau of Local Roads & Streets ..... to allow local agencies to construct quality PCC pavements for low volume roads.	
430	"Paving Brick and Concrete Paver Pavements and Sidewalks" (Eff 1-1-04) Developed by the Bureau ..... of Local Roads & Streets and the Bureau of Materials & Physical Research to provide statewide requirements for paving brick and concrete paver pavements and sidewalks.	
442	"Bituminous Patching Mixtures for Maintenance Use" (Eff 1-1-04). Developed by the Bureau of Local Roads ..... & Streets to reference approved bituminous patching mixtures.	
451	"Crack Filling Bituminous Pavement with Fiber-Asphalt" (Eff. 10-1-91)(Rev. 1-1-02).....	
503-1	"Furnishing Class SI Concrete" (Eff. 10-1-73)(Rev. 1-1-02).....	
503-2	"Furnishing Class SI Concrete (Short Load)" (Eff. 1-1-89) (Rev. 1-1-02). Developed by the Bureau of Local ..... Roads and Streets to allow a load charge to be added when short loads are expected during the contract.	
542	"Pipe Culverts, Type (Furnished)" (Eff. 9-1-64) (Rev. 1-1-02).....	
663	"Calcium Chloride Applied" (Eff. 6-1-58) (Rev. 1-1-02).....	
671	<b>Rescinded</b> .....	
701	"Flagger Certification" (Eff. 1-1-93) (Rev. 1-1-02).....	
702	X "Construction and Maintenance Signs" (Eff 1-1-04) Developed by the Bureau of Local Roads & Streets to ..... require florescent orange sheeting and a minimum sign size of 48" X 48" on construction and maintenance signs.	35
1004	"Coarse Aggregate for Bituminous Surface Treatment" (Eff. 1-1-02). Developed by the Bureau of Materials & ..... Physical Research, the Bureau of Local Roads & Streets, and Local Agencies to provide a coarser mix when aggregate producers have adjusted the CA-16 gradation according to the Aggregate Gradation Control System (AGCS) to a finer mix for Hot-Mix Asphalt.	
1013	"Rock Salt (Sodium Chloride)" (Eff. 8-1-69) (Rev. 1-1-02).....	

BDE SPECIAL PROVISIONS  
For The June 17, 2005 Letting

The following special provisions indicated by an "x" are applicable to this contract and will be included by the Project Development and Implementation Section of the BD&E. An \* indicates a new or revised special provision for the letting.

<u>File Name</u>	<u>Pg.#</u>		<u>Special Provision Title</u>	<u>Effective</u>	<u>Revised</u>
80099			Accessible Pedestrian Signals (APS)	April 1, 2003	
80141			Additional Award Criteria	June 1, 2004	
80108			Asbestos Bearing Pad Removal	Nov. 1, 2003	
72541			Asbestos Waterproofing Membrane and Asbestos Bituminous Concrete Surface Removal	June 1, 1989	June 30, 1994
80128			Authority of Railroad Engineer	July 1, 2004	
80065			Bituminous Base Course/Widening Superpave	April 1, 2002	April 1, 2004
80050	36	X	Bituminous Concrete Surface Course	April 1, 2001	April 1, 2003
80142	37	X	Bituminous Equipment, Spreading and Finishing Machine	Jan. 1, 2005	
80066			Bridge Deck Construction	April 1, 2002	April 1, 2004
50261			Building Removal-Case I (Non-Friable and Friable Asbestos)	Sept. 1, 1990	Aug. 1, 2001
50481			Building Removal-Case II (Non-Friable Asbestos)	Sept. 1, 1990	Aug. 1, 2001
50491			Building Removal-Case III (Friable Asbestos)	Sept. 1, 1990	Aug. 1, 2001
50531			Building Removal-Case IV (No Asbestos)	Sept. 1, 1990	Aug. 1, 2001
<del>80118</del>			<del>Butt Joints</del>	<del>April 1, 2004</del>	<del>April 1, 2005</del>
80031			Calcium Chloride Accelerator for Portland Cement Concrete Patching	Jan. 1, 2001	
80077			Chair Supports	Nov. 1, 2002	Nov. 2, 2002
80051	38	X	Coarse Aggregate for Trench Backfill, Backfill and Bedding	April 1, 2001	Nov. 1, 2003
80094	45	X	Concrete Admixtures	Jan. 1, 2003	July 1, 2004
80112			Concrete Barrier	Jan. 1, 2004	April 2, 2004
80102			Corrugated Metal Pipe Culverts	Aug. 1, 2003	July 1, 2004
80113	50	X	Curb Ramps for Sidewalk	Jan. 1, 2004	
80114	53	X	Curing and Protection of Concrete Construction	Jan. 1, 2004	
80029	61	X	Disadvantaged Business Enterprise Participation	Sept. 1, 2000	June 1, 2004
<del>80144</del>			<del>Elastomeric Bearings</del>	<del>April 1, 2005</del>	
31578			Epoxy Coating on Reinforcement	April 1, 1997	Jan. 1, 2003
80041	69	X	Epoxy Pavement Marking	Jan. 1, 2001	Aug. 1, 2003
80055			Erosion and Sediment Control Deficiency Deduction	Aug. 1, 2001	Nov. 1, 2001
80103	71	X	Expansion Joints	Aug. 1, 2003	
<del>80101</del>	72	X	<del>Flagger Vests</del>	<del>April 1, 2003</del>	<del>April 1, 2005</del>
80079	73	X	Freeze-Thaw Rating	Nov. 1, 2002	
80072			Furnished Excavation	Aug. 1, 2002	Nov. 1, 2004
80054	74	X	Hand Vibrator	Nov. 1, 2003	
80109			Impact Attenuators	Nov. 1, 2003	
80110			Impact Attenuators, Temporary	Nov. 1, 2003	April 1, 2004
80104	75	X	Inlet Filters	Aug. 1, 2003	
80080			Insertion Lining of Pipe Culverts	Nov. 1, 2002	Aug. 1, 2003
80067	77	X	Light Emitting Diode (LED) Signal Head	April 1, 2002	Aug. 1, 2003
80081	79	X	Lime Gradation Requirements	Nov. 1, 2002	
<del>80133</del>			<del>Lime Stabilized Soil Mixture</del>	<del>Nov. 1, 2004</del>	<del>April 1, 2005</del>
80045			Material Transfer Device	June 15, 1999	March 1, 2001
80137			Minimum Lane Width with Lane Closure	Jan. 1, 2005	
80138			Mulching Seeded Areas	Jan. 1, 2005	
80082			Multilane Pavement Patching	Nov. 1, 2002	
80129			Notched Wedge Longitudinal Joint	July 1, 2004	
80069			Organic Zinc-Rich Paint System	Nov. 1, 2001	Aug. 1, 2003
80116	80	X	Partial Payments	Sept. 1, 2003	
80013			Pavement and Shoulder Resurfacing	Feb. 1, 2000	July 1, 2004
53600	81	X	Pavement Thickness Determination for Payment	April 1, 1999	Jan. 1, 2004
80022	86	X	Payment to Subcontractors	June 1, 2000	Sept. 1, 2003
80130	87	X	Personal Protective Equipment	July 1, 2004	
80134			Plastic Blockouts for Guardrail	Nov. 1, 2004	
80073			Polymer Modified Emulsified Asphalt	Nov. 1, 2002	
80119			Polyurea Pavement Marking	April 1, 2004	
80124			Portable Changeable Message Signs	Nov. 1, 1993	April 2, 2004
80139	88	X	Portland Cement	Jan. 1, 2005	



<u>File Name</u>	<u>Pg.#</u>		<u>Special Provision Title</u>	<u>Effective</u>	<u>Revised</u>
80083	89	X	Portland Cement Concrete	Nov. 1, 2002	
80036			Portland Cement Concrete Patching	Jan. 1, 2001	Jan. 1, 2004
419	90	X	Precast Concrete Products	July 1, 1999	Nov. 1, 2004
80120			Precast, Prestressed Concrete Members	April 1, 2004	
80084	91	X	Preformed Recycled Rubber Joint Filler	Nov. 1, 2002	
80015			Public Convenience and Safety	Jan. 1, 2000	
<del>80121</del>			<del>PVC Pipeliner</del>	<del>April 1, 2004</del>	<del>April 1, 2005</del>
80122			Railroad, Full-Actuated Controller	April 1, 2004	
34261			Railroad Protective Liability Insurance	Dec. 1, 1986	May 1, 1988
80105			Raised Reflective Pavement Markers (Bridge)	Aug. 1, 2003	
80011	92	X	RAP for Use in Bituminous Concrete Mixtures	Jan. 1, 2000	April 1, 2002
80032			Remove and Re-Erect Steel Plate Beam Guardrail and Traffic Barrier Terminals	Jan. 1, 2001	Jan. 1, 2005
80085			Sealing Abandoned Water Wells	Nov. 1, 2002	
80131			Seeding and Sodding	July 1, 2004	Nov. 1, 2004
80132	96	X	Self-Consolidating Concrete for Precast Products	July 1, 2004	
80096			Shoulder Rumble Strips	Jan. 1, 2003	
80140			Shoulder Stabilization at Guardrail	Jan. 1, 2005	
<del>80135</del>	<del>93</del>	<del>X</del>	<del>Soil Modification</del>	<del>Nov. 1, 2004</del>	<del>April 1, 2005</del>
80070			Stabilized Subbase and Bituminous Shoulders Superpave	April 1, 2002	July 1, 2004
80127			Steel Cost Adjustment	April 2, 2004	July 1, 2004
80086	104	X	Subgrade Preparation	Nov. 1, 2002	
80136			Superpave Bituminous Concrete Mixture IL-4.75	Nov. 1, 2004	
80010			Superpave Bituminous Concrete Mixtures	Jan. 1, 2000	April 1, 2004
80039			Superpave Bituminous Concrete Mixtures (Low ESAL)	Jan. 1, 2001	April 1, 2004
80075			Surface Testing of Pavements	April 1, 2002	July 1, 2004
<del>80145</del>			<del>Suspension of Slipformed Parapets</del>	<del>June 11, 2004</del>	
80092			Temporary Concrete Barrier	Oct. 1, 2002	Nov. 1, 2003
80087			Temporary Erosion Control	Nov. 1, 2002	
80008			Temporary Module Glare Screen System	Jan. 1, 2000	
80106			Temporary Portable Bridge Traffic Signals	Aug. 1, 2003	
80098			Traffic Barrier Terminals	Jan. 1, 2003	
57291	105	X	Traffic Control Deficiency Deduction	April 1, 1992	Jan. 1, 2005
20338			Training Special Provisions	Oct. 15, 1975	
80107	106	X	Transient Voltage Surge Suppression	Aug. 1, 2003	
80123	108	X	Truck Bed Release Agent	April 1, 2004	
80048	109	X	Weight Control Deficiency Deduction	April 1, 2001	Aug. 1, 2002
80090			Work Zone Public Information Signs	Sept. 1, 2002	Jan. 1, 2005
80125			Work Zone Speed Limit Signs	April 2, 2004	April 15, 2004
<del>80126</del>			<del>Work Zone Traffic Control</del>	<del>April 2, 2004</del>	<del>Jan. 2, 2005</del>
80097	111	X	Work Zone Traffic Control Devices	Jan. 1, 2003	Nov. 1, 2004
80071	113	X	Working Days	Jan. 1, 2002	

The following special provisions have been **deleted** from use:

- 80111 Additional Bidder Responsibility This special provision has been replaced by the BDE Special Provision, "Additional Award Criteria".
- 43761 Driving Guardrail Posts This special provision has been made obsolete by revising Standard 630201 and issuing the BDE Special Provision, "Shoulder Stabilization at Guardrail".
- 80091 Underdrain Operations This special provision is no longer required and has been deleted.

The following special provisions are in the 2005 Supplemental Specifications and Recurring Special Provisions:

<u>File Name</u>	<u>Special Provision Title</u>	<u>New Location</u>	<u>Effective</u>	<u>Revised</u>
80052	Adjusting Frames and Grates	Sections 602, 603, and 1043	Aug. 1, 2001	Nov. 1, 2001
80093	Articulated Block Revetment Mat	Sections 285 and 1005	Jan. 1, 2003	
80078	Controlled Aggregate Mixing System	Sections 311, 351, and 481	Nov. 1, 2002	
80100	Epoxy Coatings for Steel Reinforcement	Section 1006	April 1, 2003	
80095	Precast Block Revetment Mat	Sections 285 and 1005	Jan. 1, 2003	
80074	Shoulder Inlets with Curb	Section 610	Aug. 1, 2002	
80117	Stone for Erosion Protection, Sediment Control, and Rockfill	Sections 281 and 1005	Jan. 1, 2004	
80088	Traffic Structures	Sections 1069 and 1077	Nov. 1, 2002	

The following special provisions require additional information from the designer. The additional information needs to be included in a separate document attached to this check sheet. The Project Development and Implementation section will then include the information in the applicable special provision. The Special Provisions are:

- Building Removal-Case I
- Building Removal-Case II
- Building Removal-Case III
- Building Removal-Case IV
- DBE Participation
- Material Transfer Device
- Railroad Protective Liability Insurance
- Training Special Provisions
- Working Days

## STATE OF ILLINOIS SPECIAL PROVISIONS

)\*\*(  
7

The following Special Provisions supplement the "Standard Specifications for Road and Bridge Construction", Adopted January 1, 2002, the latest edition of the "Manual on Uniform Traffic Control Devices for Streets and Highways", and the "Manual of Test Procedures for Materials", in effect on the date of the invitation for bids; and the Supplemental Specifications and Recurring Special Provisions indicated on the Check Sheet included herein which apply to and govern the construction of Section 02-00180-01-PV in the City of Granite City, Madison County, and in case of conflict with any part or parts of said specifications, the said Special Provisions shall take precedence and shall govern.

### **LOCATION OF PROJECT**

This project is located along 20<sup>th</sup> Street from the intersection of Madison Avenue and 20<sup>th</sup> Street to the intersection of Iowa Street and 20<sup>th</sup> Street.

### **DESCRIPTION OF PROJECT**

This project consists of removal and reconstruction of the roadway surface along 20<sup>th</sup> Street.

Items of work include:

Pavement Removal, Median Removal, Curb Removal, Sidewalk Removal, Driveway Pavement Removal, Portland Cement Concrete Pavement, Driveway Pavement, Sidewalk, Combination Curb and Gutter B-6.12, Storm Sewer, traffic signal upgrades and all necessary and collateral work to complete the contract.

### **TRAFFIC CONTROL PLAN**

Traffic control shall be in accordance with the applicable sections of the Standard Specifications for Road and Bridge Construction, the applicable guidelines contained in the "Illinois Manual on Uniform Traffic Control Devices for Streets and Highways", these special provisions, and any special details and Highway Standards contained herein and in the plans.

At the preconstruction meeting, the Contractor shall furnish the name of the individual in his direct employ who is to be responsible for the actual installation and maintenance of the traffic control for this project. If the actual installation and maintenance are to be accomplished by a subcontractor, consent shall be requested of the Engineer at the time of the preconstruction meeting in accordance with Article 108.01 of the Standard Specifications for Road and Bridge Construction. This shall not relieve the Contractor of the foregoing requirement for a responsible individual in his direct employ. The Department will Contractor provide the name of its representative who will be responsible for the administration of the Traffic Control Plan.

Special attention is called to Article 107.09 and 107.14 of the Standard Specifications for Road and Bridge Construction and the following Highway Standards: 701301, 701311, 701501, 701606, 701701, 701801, 702001, and BLR 22.

In addition, the following special provision(s) will also govern traffic control for this project:

Traffic Control and Protection

Barricades or Drums.

Traffic shall be maintained through and around the work zone associated with the construction of the traffic signals in accordance with the Special Provisions for Traffic Control and Protection included herein.

### **TRAFFIC CONTROL AND PROTECTION**

This work shall conform to the applicable portions of Section 700 of the Standard Specifications and the Traffic Control Plans. This item of work shall include the furnishing, installing, maintaining, relocating, and removing of all traffic control devices used for the purpose of regulating, warning or directing the traffic during the construction of this project.

All traffic control devices used on this project shall conform to the Plans, Special Provisions, Traffic Control Standards, Standard Specifications for Traffic Control Items, and the Illinois Manual on Uniform Traffic Control Devices for Streets and Highways. No modification of these requirements will be allowed without prior written approval of the Engineer.

Traffic control devices shall include all temporary traffic control and regulatory signs including temporary stop signs as described herein, and their supports, temporary pavement markings, barricades with sand bags, plastic drums, channelizing devices, warning lights, arrowboards if necessary, flaggers, or any other device used for the purpose of regulating, warning, or guiding traffic through the construction zone and guiding traffic on the detour route.

The Contractor shall be responsible for the proper location, installation, and arrangement of all traffic control devices as shown on the plans, or as directed by the Engineer. Special attention shall be given to advance warning signs during construction operations in order to keep lane assignment consistent with barricade placement and stage construction at all times. The Contractor shall cover or remove all traffic control devices that are inconsistent with lane assignment patterns during the transition from one construction stage to another.

The Contractor shall contact the Engineer at least 72 hours in advance of beginning work, to allow for coordination between the Traffic Control Plan and the various items of work required.

When traveling in lanes open to public traffic, the Contractor's vehicles shall always move with and not against the flow of traffic. These vehicles shall enter or leave work areas in a manner that will not be hazardous to or interfere with traffic and shall not park or stop except within designated work areas. Personal vehicles shall not park within the right-of-way except in specific areas designated for parking.

Any drop off from pavement open to traffic which is greater than three inches, but less than six inches, within eight feet of the pavement edge shall be protected by Type I or Type II barricades equipped with mono-directional steady burn lights at 100-foot center-to-center

spacing. If the drop off within eight feet of the pavement edge exceeds six inches, the barricades mentioned above shall be placed at 50-foot center-to-center spacing. Other potential hazards located within the project limits shall be protected by Type I or Type II barricades with steady burning or flashing lights. Barricades that must be placed in excavated areas shall have leg extensions installed such that the top of the barricade is in compliance with the height requirements of Standard 702001. Vertical panels or other delineating devices may be substituted for Type I or Type II barricades with the approval of the Engineer.

The Contractor shall erect and maintain the traffic control and detour route as shown on the traffic control plan sheet. The Contractor will be required to maintain access for the residents living in the project boundaries as specified in the special provisions.

The Contractor will be required to give the residents and the Resident Engineer 72 hours notice of closure of private entrances.

During the period in which the private entrances are closed the Contractor should direct the residents to park along the side streets in the adjoining subdivision.

Traffic Control Highway Standards 701301, 701311, 701501, 701606, 701701, 701801, *BLR 22* and 702001 will not be paid for separately but shall be considered incidental to TRAFFIC CONTROL AND PROTECTION.

Revisions in the staging of construction, requested by the Contractor, may require traffic control to be installed in accordance with standards and/or designs other than those included in the plans. Revisions or modifications to the traffic control shown in the contract shall be submitted by the Contractor for approval by the Engineer.

This work will be paid for at the contract unit price per lump sum for TRAFFIC CONTROL AND PROTECTION, which price will be payment in full for furnishing, installing, maintaining, relocating and removing all traffic control devices as noted herein and shown on the plans, and no additional compensation or remuneration will be allowed.

### **SIGN REMOVAL AND REPLACEMENT**

This item of work shall consist of furnishing all labor, material and equipment necessary to remove the existing traffic signs (i.e. stop signs, speed signs, etc.), stockpile these signs at a location designated by the Engineer and replace these signs in accordance with the Illinois Manual on Uniform Traffic Control Items.

The Contractor shall be responsible for the damage or destruction of property of any character resulting from neglect, misconduct or omission in his/her manner or method of execution or non-execution of the work, or caused by defective work or the use of unsatisfactory materials, and such responsibility shall not be released until the work shall have been completed and accepted and the requirements of the specifications complied with.

If sign materials are damaged or destroyed due to circumstances beyond the control of the Contractor, these materials will be paid for in accordance with Article 109.04 of the Standard Specifications for Road and Bridge Construction. The Engineer's judgment shall be final in determining if damaged or destroyed sign materials are due to circumstances beyond the Contractor's control.

This item of work shall be included in the contract lump sum price bid for TRAFFIC CONTROL AND PROTECTION, and no additional compensation will be allowed for this item of work.

### **BARRICADES OR DRUMS**

Prior to commencing construction, sufficient barricades or drums conforming to Standard 702001 and the following requirements shall be on the job site ready for use in the construction of this project.

Type I or Type II barricades or drums used in channelizing traffic and protection of hazards shall be equipped with one Type C steady burning light meeting the requirements of Article 1084.01 of the Standard Specifications.

Type I or Type II barricades used in channelization shall be stabilized in a manner allowed by Article 702.03.

This item shall be considered included in the contract lump sum price for TRAFFIC CONTROL AND PROTECTION, and no additional compensation or remuneration will be allowed.

### **ACCESS TO ENTRANCES**

As described in the Special Provision for TRAFFIC CONTROL AND PROTECTION, the contractor shall provide and maintain access to all existing entrances and side roads adjacent to 20<sup>th</sup> Street during construction of this section in accordance with the Special Provisions and Article 107.09 of the Standard Specifications. The furnishing, placing, maintaining, and removal of such aggregate for temporary access will be paid for at the contract unit price per ton for AGGREGATE FOR TEMPORARY ACCESS and no additional compensation will be allowed. An estimated quantity for this item of work is included in the plans.

For the majority of the construction, access may be provided by way of the existing and proposed roadway surface. However, from time to time during the course of construction, the contractor will be required to provide aggregate for temporary access to commercial entrances.

It is understood that the contractor shall be solely responsible for providing reasonable access for all entrances during the construction of this section in accordance with the Special Provisions and with Article 107.09 of the Standard Specifications.

### **AGGREGATE FOR TEMPORARY ACCESS**

This item of work is included in the contract for the purpose of providing surfacing for temporary access through the construction zone and to entrances during construction. This item shall only be used on those occasions when the contractor is directed by the engineer. Said surfacing may not be required at all or on multiple occasions.

~~The material for aggregate for temporary access shall conform to the requirements for CA-6.~~ Aggregate for temporary access may be placed by tailgating and blading. Compaction shall be

provided to the satisfaction of the Engineer. Included with this item of work shall be any interim maintenance that may be required and as directed by the Engineer. At such time as the aggregate is no longer needed, the contractor shall suitably remove and dispose of the material beyond the limits of construction.

All labor, materials, and equipment necessary to install, maintain, remove, and suitably dispose of the temporary aggregate surface shall be paid for at the contract unit price per ton for AGGREGATE FOR TEMPORARY ACCESS based upon weight tickets furnished by the supplier.

### **DISPOSAL OF SURPLUS MATERIALS**

All surplus materials resulting from the removal of culverts, inlets, trees, sidewalks, street surfacing, etc., which cannot be used for embankment and which are deemed by the Engineer to have no salvageable value to the City of Granite City shall be removed from the site by the Contractor and disposed of in accordance with the requirements of all regulatory agencies. Surplus material that is suitable for embankment shall be segregated and stockpiled for use in earth fill between the back of the curb and the right-of-way as shown on the cross-sections. Surplus material, which is deemed by the Engineer to have salvageable value to the City of Granite City; shall be stockpiled on the right-of-way by the Contractor for pick-up and reuse by the Granite City Street Department. The cost of this work shall be included in the cost of the individual removal pay items, at no additional payment will be allowed.

### **JOINT UTILITY LOCATING INFORMATION FOR EXCAVATORS (J.U.L.I.E.)**

This work shall be done in accordance with Article 107.31 of the Standard Specifications except as herein modified.

Because a minimum of 48 (forty-eight) hours advance notice is required for notification to utilities, the Contractor will be required to give the Resident Engineer 96 (ninety-six) hours notice, in writing, for a specific area prior to beginning any excavation.

Locations of proposed storm sewers, sign posts, guardrail, sign, light, or signal foundations, etc. shall be staked and then notice provided as above.

If any of the location markers placed by a utility company in conformance with this procedure are destroyed by Contractor operations, the Contractor shall immediately notify the utility owner and bear the costs of remarking the facilities at his own cost and expense. Compliance with this special provision shall be considered included in the contract and no additional compensation will be allowed for any costs incurred.

### **COOPERATION WITH UTILITIES**

The following companies have utility facilities within the limits of this project:

City of Granite City  
Illinois American Water Company  
Charter Communications

Ameren IP  
SBC  
Air Products Manufacturing Corp.  
United States Steel Corporation

In addition to the requirements of Article 105.07 of the Standard Specifications, the Contractor shall coordinate his operations with the proposed utility adjustments to minimize delays in construction of the project.

The Contractor's attention is directed to the Status of utilities contained elsewhere herein and the estimated completion dates for the various relocations and adjustments.

The Contractor shall coordinate his activities to allow for any inconvenience or delay caused by the adjustment of utilities during construction.

Compliance with this special provision shall be in accordance with Article 105.07 of the Standard Specifications, and no additional compensation or remuneration will be allowed for any delays, inconvenience or damage sustained by the Contractor due to any interference from utility appurtenances or the operation of moving them, or on account of any special construction methods required in prosecuting the proposed work due to the existence of said appurtenances either in their present or relocated positions.

#### **CONSTRUCTION EASEMENTS AND EXCESS RIGHT-OF-WAY**

Temporary construction easements which provide for work that is to be done on private or commercial property are depicted on the plans, and shall not be used for any purpose other than that which is necessary to adjust the property to that required by the contract plans.

The Contractor shall not use the easement or excess right-of-way areas for storage of materials or equipment.

Compliance with this Special Provision shall be considered included in the cost of the contract and no additional compensation will be allowed for any costs incurred.

#### **CONNECTING TO EXISTING MANHOLE**

This item of work shall consist of furnishing all labor, equipment and materials necessary to connect proposed storm sewer to existing manholes at locations as shown in the plans. This work shall be done in accordance with Section 602 of the Standard Specifications.

The Contractor shall take special care when making the opening for the proposed storm sewer so as not to damage the existing structure. The voids remaining in the opening through which the pipe enters the structure walls shall be completely and firmly rammed full of material consisting of non-shrink grout.

This work will be paid for at the contract unit price per each for **CONNECTION TO EXISTING MANHOLE**, and no other compensation will be allowed for any costs incurred.



## **INCIDENTAL BITUMINOUS SURFACING, SUPERPAVE**

This work shall include bituminous side roads pavements, existing bituminous driveway pavements, and miscellaneous paving removed to accommodate the new construction as directed by the Engineer. The bituminous surfacing shall meet the requirements of Sections 301, 406, and 408 of the Standard Specifications. The limits of removal and replacement shall be determined by the Engineer in the field. Saw cutting for the removal of these areas shall be included in the cost of pavement removal specified.

This item of work shall be paid for at the contract unit price per ton for INCIDENTAL BITUMINOUS SURFACING, SUPERPAVE, and no additional compensation shall be allowed for complying with the requirements of this special provision.

## **TRAFFIC SIGNAL TURN-ON AND FINAL INSPECTION**

Revised: January 1, 2002

The Contractor may request a turn-on and final inspection of complete traffic signal work at each separate location.

For a new traffic signal installation (at a location where traffic signals did not previously exist) the Contractor must advise the Department a minimum of 10 calendar days prior to the proposed turn-on date to allow for an appropriate press release to be issued. The turn-on date of new controllers at locations where traffic signals are being modified or replaced shall be in accordance with the shut down period allowed as specified elsewhere in these provisions.

The Department or responsible local agency will begin paying energy consumption charges on the turn-on date. Facility charges will be paid under the contract up to 30 days prior to the turn-on date. However, the Contractor is responsible for payment of any energy consumption charges prior to turn-on. Facility charges prior to turn-on are to be submitted for payment under Article 109.05 of the Standard Specifications along with the utility company connection charges in accordance with Section 805. Waiting for electric service to be connected by the utility company will not be a cause to suspend working day charges. However, working days will not be charged while waiting for turn-on if all other contract work is complete including electric service connection.

Subsequent to turn-on a final inspection must be requested a minimum of 7 calendar days prior to the proposed inspection date. The Department or responsible local agency will assume maintenance responsibility; including knockdowns at the time that all deficiencies noted during the final inspection are corrected to the satisfaction of the Engineer. Acceptance of the controller will not be made until the requirements of Section 802 are met.

## **VEHICLE DETECTOR LOOP INSTALLATION**

Revised: January 1, 2002

Add the following to the provisions for detector loop installation:

Replace the third paragraph of Article 886.04 (a) with the following:

The loop wire shall be held tightly in the bottom of the sawed slot by means of a plastic foam type material. The "backer rod" shall completely cover the wire and provide a barrier between

the wire and the sealant. The loop wires not embedded in the pavement shall be evenly twisted approximately 16 turns per meter (5 turns per foot). The depth of the sawed slot shall be as required to provide a minimum of one-inch clearance between the surface of the pavement and the top of the backer rod. When loops are placed in the binder or base course of bituminous pavement and will be covered by an additional surface course, the clearance may be reduced to one-half inch.

## **LIGHT EMITTING DIODE (LED) SIGNAL FACE RETROFIT (BALL INDICATIONS)**

### **1.0 PURPOSE**

This specification provides the minimum performance requirements for 12 in LED traffic signal modules. This specification refers to definitions and practices described in "Vehicle Traffic Control Signal Heads" published in the *Equipment and Materials Standards of the Institute of Transportation Engineers*, referred to in this document as "VTCSH". The multiple LED light source should be the latest technology available on the market. The LEDs utilized shall be AlInGaP technology for red, amber and yellow indications, or InGaN for green indications.

### **2.0 PHYSICAL AND MECHANICAL REQUIREMENTS**

#### **2.1 General**

LED traffic signal modules (the module) designed as retrofit replacements for existing signal lamps shall not require special tools for installation. Retrofit replacement LED modules shall fit into existing traffic signal housings built to the VTCSH Standard without modification to the housing.

Installation of a retrofit replacement LED signal module into an existing signal housing shall only require the removal of the following existing components: i.e., lens, lamp module and gaskets. It shall be weather tight and fit securely in the housing; and shall connect directly to existing electrical wiring.

The installation of the signal module shall not require the removal of the incandescent lamp reflector or socket assembly.

#### **2.2 LED Signal Module**

2.2.1 The retrofit LED module shall be capable of replacing the optical unit.

2.2.2 Tinting (Optional) -The lens shall be tinted or shall use transparent film or materials with similar characteristics.

2.2.3 The LED module lens shall be a replaceable part without the need to replace the complete LED module.

#### **2.3 Environmental Requirements**

2.3.1 The LED module shall be rated for use in the ambient operating temperature range of -40°C (-40°F) to +74°C (+165°F).

2.3.2 The LED module shall be protected against dust and moisture intrusion as per NEMA Standard 250-1991 requirements, for Type 4 enclosures to protect all internal LED, electronic, and electrical components.

2.3.3 The LED signal module lens shall be UV stabilized.

2.3.4 The lens shall be smooth on the outside and be specifically designed with a sloped face to reduce sun reflections (Sun Phantom).

2.3.5 The LED module must be supplied with an installed gasket.

## 2.4 Construction

2.4.1 The LED module shall be a single, self-contained device, not requiring on-site assembly for installation into an existing traffic signal housing. The power supply must fit and mount inside the LED module.

2.4.2 The assembly and manufacturing process for the LED assembly shall be designed to assure all internal LED and electronic components are adequately supported to withstand mechanical shock and vibration from high winds and other sources.

2.4.3 In order to prevent water seepage between back cover and electrical wire, or between copper and insulation of the wires, the electrical connection between wires and power supply unit shall be done using over-molded lug connectors. Electrical wires shall not be permitted to penetrate LED housing.

## 2.5 Materials

2.5.1 Materials used for the lens and LED module construction shall conform to ASTM specifications where applicable.

2.5.2 Enclosures containing the power supply and electronic components of the LED module shall be made of UL94VO flame retardant materials. The lens of the LED module is excluded from this requirement.

## 2.6 Module Identification

2.6.1 Each LED module shall be identified on the backside with the manufacturer's name and serial number.

2.6.2 The following operating characteristics shall be identified: nominal operating voltage, power consumption, and Volt-Ampere.

2.6.3 LED modules shall have a prominent and permanent vertical indexing indicator, i.e., UP ARROW or the word UP or TOP, for correct indexing and orientation inside a signal housing.

## 3.0 PHOTOMETRIC REQUIREMENTS

### 3.1 Luminous Intensity & Distribution

3.1.1 The maintained minimum luminous intensity values for LED modules throughout the warranty period, under the operating conditions defined in Sections 2.3.1, 4.2.1 and 5.4.2, and at the end of the warranty period, shall not be less than the values shown in Table 1.

3.1.2 When operating within the temperature range specified in Section 2.3.1 during the warranty period, the maximum luminous intensity for the 8-inch or 12-inch signals shall not exceed 800 candelas for the Red, 1,600 candelas for the Green, and 1,600 candelas for the Yellow.

3.1.3 The optical assembly shall diffuse the light output and provide uniform illumination across the entire surface of circular lenses. Individual LED's shall not be visible to the observer of indications displayed by traffic signal modules, providing an incandescent type appearance. To ensure even illumination and reliability, 12" LED full ball modules shall consist of a minimum of 100 InGaN (green) or AlInGaP (red and amber) LEDs and 8" LED full balls shall consist of a minimum of 30 InGaN or AlInGaP LEDs.

### 3.2 Chromaticity

The measured chromaticity coordinates of LED modules shall be between 500 nm and 650 nm, conforming to the chromaticity requirements of Section 8.04 and Figure 1 of the VTCSH standard.

Table 1. Maintained Minimum Luminous Intensity for LED Signal Modules Candlepower Values (candelas (cd))

Vertical Angle Down	Horiz. Angle Left & Right	12-inch Signal		
		Red	Yellow	Green
2.5°	2.5°	339	678	678
	7.5°	251	501	501
	12.5°	141	283	283
	17.5°	77	154	154
7.5°	2.5°	226	452	452
	7.5°	202	404	404
	12.5°	145	291	291
	17.5°	89	178	178
	22.5°	38	77	77
	27.5°	16	32	32
12.5°	2.5°	50	101	101
	7.5°	48	97	97
	12.5°	44	89	89
	17.5°	34	69	69
	22.5°	22	44	44
	27.5°	16	32	32
17.5°	2.5°	22	44	44
	7.5°	22	44	44
	12.5°	22	44	44

	17.5°	22	44	44
	22.5°	20	41	41
	27.5°	16	32	32

## 4.0 ELECTRICAL

### 4.1 General

All wiring and terminal blocks shall meet the requirements of Section 13.02 of the VTCSH Standard. Two secured, color coded, 914 mm (36 in) long 600 V, 20 AWG minimum, jacketed wires, conforming to the National Electrical Code, rated for service at +105°C, are to be provided for electrical connection.

### 4.2 Voltage Range

4.2.1 LED modules shall operate from a 60 + 3 cycle ac line power over a voltage range from 80 Vac rms to 135Vac rms. The current draw shall be sufficient to ensure compatibility and proper triggering and operation of load current switches and conflict monitors in the signal controller that the procuring traffic authority customer has in use.

4.2.2 Nominal operating voltage for all measurements shall be 120 + 3 Volts rms.

4.2.3 Fluctuations in line voltage over the range of 80Vac to 135Vac shall not affect luminous intensity by more than + 10 percent.

4.2.4 The LED circuitry shall prevent flickering at less than 100 Hz over the voltage range specified in Section 4.2.1.

#### 4.2.5 Low Voltage Turn Off

There shall be no illumination from the module when the applied voltage is less than 35 volts AC. To test for this condition the unit must first be fully illuminated at the nominal operating voltage. The applied voltage is then reduced to the point that there is no illumination. This point must be greater than 35 volts AC. The same requirement should apply in rising voltage from 0 to 35 with no visible illumination.

#### 4.2.6 Turn-On and Turn-Off Time:

The modules shall reach 90% of their full illumination (turn-on) within 100 msec (+ or - 10%) after the application of the nominal operating voltage. The LED modules shall not be illuminated (turn-off) within 100 msec (+ or - 10%) after the removal of the nominal operating voltage.

### 4.3 Transient Voltage Protection

4.3.1 The LED module on-board circuitry shall include voltage surge protection to withstand high-repetition noise transients and low-repetition, high-energy transients as stated in Section 2.1.6, NEMA Standard TS-2, 1992.

### 4.4 LED Drive Circuitry

4.4.1 The individual LED light sources shall be wired so that the catastrophic failure of one LED, will result in the loss of no more than 5 percent of total light output.

4.4.2 The power supply must be current regulated.

#### 4.5 Electronic Noise

The LED module and the associated on-board circuitry must meet Federal Communications Commission (FCC) Title 47, SubPart B, Section 15 regulations concerning the emission of electronic noise.

#### 4.6 Power Factor (PF) and AC Harmonics

4.6.1 LED modules shall provide a power factor of 0.90 or greater when operated at nominal operating voltage, and 25°C (77°F).

4.6.2 Total harmonic distortion induced into an ac power line by an LED signal module, operated at nominal operating voltage, at 25°C (77°F) shall not exceed 20 percent.

#### 4.7 Wattage

Proposed LED modules shall be less than or equal to the base wattage shown below at 25 degrees C.

Type	Wattage
12" Red Ball	10 or less
12" Yellow Ball	22 or less
12" Green Ball	12 or less

### 5.0 QUALITY ASSURANCE

#### 5.1 General

##### 5.1.1 Quality Management System

The LED signal manufacturer's quality management system shall be ISO 9002 registered.

##### 5.1.2 Quality Assurance Program

LED modules shall be manufactured in accordance with a vendor quality assurance (QA) program. The QA program shall include two types of quality assurance: (1) design quality assurance, and (2) production quality assurance. The production quality assurance shall include statistically controlled routine tests to ensure minimum performance levels of LED modules built to meet this specification.

##### 5.1.3 Record Keeping

QA process and test result documentation shall be kept on file for a minimum period of seven years.

#### 5.1.4 Conformance

LED module designs not satisfying design qualification testing and the production quality assurance testing performance requirements in Sections 5.3 and 5.4 shall not be labeled, advertised, or sold as conforming to this specification.

#### 5.2 Manufacturers' Serial Numbers

Each LED module shall be identified by a manufacturer's serial number for warranty purposes.

#### 5.3 Production Quality Assurance (QA) Testing

All new LED modules shall undergo the following Production Quality Assurance testing prior to shipment. Failure of any LED module to meet requirements of these QA tests shall be cause for rejection. QA test results shall be maintained per the requirement of Section 5.1.2.

##### 5.3.1 Module Burn-in

All LED modules or the electronic circuitry sub-assemblies, including all LEDs, shall be energized for a minimum of 24 hours, at 100 percent on-time duty cycle, in an ambient temperature of 60°C (+140°F).

##### 5.3.2 Maintained Minimum Luminous Intensity

All LED modules shall be tested for maintained minimum luminous intensity after burn-in. A single point measurement with a correlation to the intensity requirements of Table 1 in Section 3.0 may be used. The LED module shall be operated at nominal operating voltage and at an ambient temperature of 25°C (77°F).

##### 5.3.3. Power Factor

All LED modules shall be tested for power factor after burn-in per the requirements of Section 4.6.1. A commercially available power factor meter may be used to perform this measurement.

##### 5.3.4 Current

All LED modules shall be measured for current flow in Amperes after burn-in. The measured current values shall be compared against current values resulting from design qualification measurements in Section 5.4.4.1. Measured current values in excess of 120 percent of the design qualification current values shall be cause for rejection.

##### 5.3.5 Visual Inspection

All LED modules shall be visually inspected for any exterior physical damage or assembly anomalies.

#### 5.4 Design Qualification Testing

Design qualification testing shall be performed on new LED module designs, and when a major design change has been implemented on an existing design. The minimum sample quantity of LED modules shall be as stated for each test. Failure to meet requirements of any of these tests shall be cause for rejection.

Testing shall be performed once every 5 years or when the module design or LED technology has been changed. Test data shall be retained by the testing laboratory and the LED module manufacturer for a minimum period of 5 years.

#### 5.4.1 Burn-in

LED modules shall be energized for a minimum of 24 hours, at 100 percent on-time duty cycle, in an ambient temperature of +60°C (+140°F) before performing any design qualification testing.

#### 5.4.2 Maintained Minimum Luminous Intensity

5.4.2.1 After burn-in, a random sample of six LED modules shall be tested for maintained minimum luminous intensity at each of the 44 points indicated in Table 1, Section 3.0. These measurements shall be recorded at an ambient temperature of 25°C after the signal has been operated for 60 min.

5.4.2.2 After burn-in, a random sample of six LED modules shall be tested for maintained minimum luminous intensity. Signals to be tested shall be mounted in a temperature testing chamber so that the lensed portion of the signal is outside the chamber and all portions behind the lens are within the chamber at a temperature of 74°C (165°F). The air temperature in front of the lens of the signal lens shall be maintained at a minimum of 49°C (120°F) during all tests.

Red and green LED modules shall be tested for luminous output at 74°C, allowing the modules to achieve thermal equilibrium for 60 minutes, while the modules are energized at nominal operating voltage, at a 100% duty cycle, a single luminous intensity measurement shall be recorded.

Yellow LED modules shall be tested for luminous output at 25°C, allowing the modules to achieve thermal equilibrium for 60 minutes, while the modules are energized at nominal operating voltage, at a 8.3% (or 1/12) duty cycle or (5 sec On/55 sec Off).

A single point correlation measurement, accounting for measurement variables, shall be made at 25°C (77°F). For Red and green a measurement shall be made at 74°C (165°F) (lens at 49°C (120°F)). The 74°C measurement factored to the 25°C measurement shall be able to be correlated to the requirements of Table 1, Section 3.0. LED modules not meeting this correlation shall be cause for rejection.

#### 5.4.3 Chromaticity

A sample of two LED modules shall be measured for chromaticity per the requirements of Section 3.4.2. A spectroradiometer shall be used for this measurement. The ambient temperature for this measurement shall be +25°C (+77°F).

#### 5.4.4 Electrical

##### 5.4.4.1 Current.

A sample of six LED modules shall be measured for current flow in Amperes. The measured current values shall be used for quality comparison of Production Quality Assurance current measurements on production modules.

##### 5.4.4.2 Power Factor (PF).

A sample of six LED modules shall be measured for power factor per the requirements of Section 4.6.1. A commercially available power factor meter may be used to perform this measurement.



5.4.4.3 Total Harmonic Distortion (THD). A sample of six LED modules shall be measured for total harmonic distortion per the requirements of Section 4.6.2. A commercially available total harmonic distortion meter may be used to perform this measurement.

5.4.4.4 Electronic Noise. A sample of one LED modules shall be tested per the requirements of Section 4.6, with reference to Class A emission limits referenced in Federal Communications Commission (FCC) Title 47, SubPart B, Section 15.

5.4.4.5 Controller Assembly Compatibility. Due to the low load current draw and high off-state impedance of LED modules, the following design qualification tests shall be performed to ensure the module design is compatible and operates properly with load current switches and conflict monitors in NEMA and Type 170 traffic signal control units.

5.4.4.5.1 Load Switch Compatibility. A sample of six LED modules shall be tested for compatibility and proper operation with load current switches. Each LED module shall be connected to a variable AC voltage supply. The AC line current into the LED module shall be monitored for sufficient current draw to ensure proper load switch operation while the voltage is varied from 80 V rms to 135 V rms. Failure of the current draw to ensure proper load current switch operation shall be cause for rejection.

5.4.4.5.2 Signal Conflict Monitor Compatibility. A sample of six LED modules shall be tested for compatibility and proper operation with signal conflict monitors. Each LED module shall be operated from a 135 V ac voltage supply. A 19.5 k $\Omega$  resistor shall be wired in series in the hot line between the LED module monitor and the ac power supply. A single-pole-single-throw switch shall be wired in parallel across the 19.5 k $\Omega$  resistor. A 220 k $\Omega$  shunt resistor shall be wired between the hot line connection and the neutral line connection and the neutral line connection on the LED module. Conflict monitor compatibility shall be tested by measuring the voltage decay across the 200 k $\Omega$  shunt resistor as follows: The single-pole-single-throw switch shall be closed, shorting out the 19.5 k $\Omega$  resistor, allowing the AC power supply to illuminate the LED module. Next, the switch shall be opened and the voltage across the 220 k $\Omega$  shunt resistor shall be measured for a decay to a value equal to or less than 10V rms within a time period equal to or less than 100 milliseconds. This test shall be repeated a sufficient number of times to ensure testing occurs at the peak of the AC line voltage cycle.

5.4.4.6 Nondestruct Transient Immunity. A sample of six LED modules shall be tested for transient immunity using the procedure described in Section 2.1.8, NEMA Standard TS 2-1992.

#### 5.4.5 Environmental

5.4.5.1 Temperature Cycling. Temperature cycling shall be performed on a sample of three LED modules per MIL-STD-883, Test method 1010. The temperature range shall be per Section 2.3. A minimum of 20 cycles shall be performed with a 30-minute transfer time between temperature extremes and a 30-minute dwell time at each temperature. LED modules under test shall be non-operating. Failure of a LED module to function properly or any evidence of cracking of the LED module lens or housing after temperature cycling shall be cause for rejection.

5.4.5.2 Moisture Resistance. Moisture resistance testing shall be performed on a sample of three LED modules per NEMA Standard 250-1991 requirements for Type 4 enclosures.

#### 5.4.5.3 Mechanical Vibration

Mechanical vibration testing shall be performed on a sample of three LED modules per MIL-STD-883, Test Method 2007, using three 4-minute cycles along each x, y, and z axis, at a force of 2.5 Gs, with a frequency sweep from 2 Hz to 120 Hz. The loosening of the lens, of any internal components, or other physical damage shall be cause for rejection.

### 6.0 WARRANTY

#### 6.1 Warranty

6.1.1 LED modules shall be replaced or repaired if an LED module fails to function as intended due to workmanship or material defects within the first 60 months from the date of delivery.

6.1.2 LED modules which exhibit luminous intensities less than the minimum values specified in Table 1 Section 3.0 within the first 60 months of the date of delivery shall be replaced or repaired.

This item will be paid for at the contract unit price each for LIGHT EMITTING DIODE (LED) SIGNAL FACE RETROFIT (BALL INDICATIONS) and no other compensation will be allowed for any costs incurred.

### **LIGHT EMITTING DIODE (LED) SIGNAL FACE RETROFIT (ARROW INDICATIONS)**

#### 1.0 PURPOSE

The purpose of this specification is to provide the minimum performance requirements for 12 in LED vehicle arrow traffic signal modules. This specification refers to definitions and practices described in "Vehicle Traffic Control Signal Heads" published in the *Equipment and Materials Standards of the Institute of Transportation Engineers*, referred to in this document as "VTCSH".

### 2.0 PHYSICAL AND MECHANICAL REQUIREMENTS

#### 2.1 General

LED vehicle arrow traffic signal modules (The Arrow) designed as retrofit replacements for existing signal lamps shall not require special tools for installation. Retrofit replacement LED arrow shall fit into existing traffic signal housings built to the VTCSH Standard without modification to the housing.

Installation of a retrofit replacement LED arrow into an existing signal housing shall only require the removal of the existing optical unit components, i.e., lens, lamp module and gaskets. It shall be weather tight, fit securely in the housing and shall connect directly to existing electrical wiring.

The installation of the signal module shall not require the removal of the incandescent lamp reflector or socket assembly.

## 2.2 LED Vehical Arrow Traffic Signal Module (The Arrow)

2.2.1 The retrofit LED arrow shall be capable of replacing the optical unit.

2.2.2 Tinting (Optional) -The lens shall be tinted or shall use transparent film or materials with similar characteristics.

2.2.3 The LED arrow lens shall be a replaceable part without the need to replace the complete LED arrow.

2.2.4 The configuration of the arrow icon is illustrated in Figure 1.

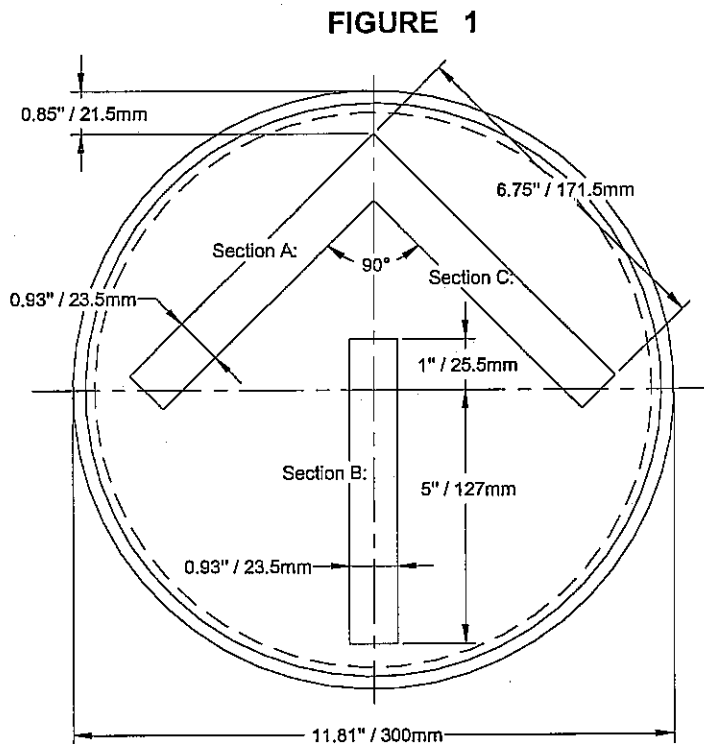

## 2.3 Environmental Requirements

2.3.1 The LED arrow shall be rated for use in the ambient operating temperature range, of  $-40^{\circ}\text{C}$  ( $-40^{\circ}\text{F}$ ) to  $+74^{\circ}\text{C}$  ( $+165^{\circ}\text{F}$ ).

2.3.2 The LED arrow shall be protected against dust and moisture intrusion per NEMA Standard 250-1991 requirements, for Type 4 enclosures to protect all internal LED, electronic, and electrical components.

2.3.3 The LED arrow lens shall be UV stabilized.

## 2.4 Construction

**2.4.1** The LED arrow shall be a single, self-contained device, not requiring on-site assembly for installation into an existing traffic signal housing. The power supply must be designed to fit and mount inside the LED arrow.

**2.4.2** The assembly and manufacturing process for the LED arrow assembly shall be designed to assure all internal LED and electronic components are adequately supported to withstand mechanical shock and vibration from high winds and other sources.

**2.4.3** In order to prevent water seepage between back cover and electrical wire, or between copper and insulation of the wires, the electrical connection between wires and power supply unit shall be done using over-molded lug connectors. Electrical wires shall not be permitted to penetrate LED housing.

## **2.5 Materials**

**2.5.1** Materials used for the module construction shall conform to ASTM specifications for the materials where applicable.

**2.5.2** Enclosures containing the power supply and electronic components of the arrow shall be made of UL94VO flame retardant materials. The lens of the arrow is excluded from this requirement.

## **2.6 Module Identification**

**2.6.1** Each LED arrow shall be identified on the backside with the manufacturer's name and serial number.

**2.6.2** The following operating characteristics shall be identified: nominal operating voltage, power consumption, and Volt-Ampere.

**2.6.3** Arrows shall have a prominent and permanent vertical indexing indicator, i.e., UP ARROW or the word UP or TOP, for correct indexing and orientation inside a signal housing.

## **3.0 PHOTOMETRIC REQUIREMENTS**

### **3.1 Luminous Intensity & Distribution**

**3.1.1** The maintained minimum luminous intensity values for LED arrows throughout the warranty period, under the operating conditions defined in Sections 2.3.1, 4.2.1 and 5.4.2, and at the end of the warranty period, shall not be less than the values shown in Table 1.

**3.1.2** The uniformity of the icon illumination shall meet a ratio of not more than 1 to 5 between the minimum and maximum illuminance measurements (in Cd/m<sup>2</sup>). A spot size of 12mm shall be used with at least three measurements taken in each of the three sections (A, B & C) shown in figure 1.

3.1.3 The optical lens should reflect a light distribution look similar to that of an incandescent lamp. Individual LEDs shall not be visible.

### 3.2 Chromaticity

The measured chromaticity coordinates of LED arrows shall be between 500 nm and 650 nm, conforming to the chromaticity requirements of Section 8.04 and Figure 1 of the VTCSH standard.

**Table 1. Maintained Minimum Luminous Intensity for the LED Vehicle Arrow  
Candlepower Values (candelas (cd))**

Vertical Down	Horiz. +/-	12-inch Signal		
		Red	Yellow	Green
2.5°	2.5°	60	150	90
	7.5°	44	110	66
	12.5°	25	62	38
	17.5°	14	35	21
7.5°	2.5°	40	100	60
	7.5°	36	90	54
	12.5°	26	65	39
	17.5°	16	40	24
	22.5°	7	17	11
12.5°	27.5°	3	7	4
	2.5°	9	23	14
	7.5°	9	22	14
	12.5°	8	20	12
	17.5°	6	15	9
	22.5°	4	10	6
17.5°	27.5°	3	7	4
	2.5°	4	10	6
	7.5°	4	10	6
	12.5°	4	10	6
	17.5°	4	9	6
	22.5°	4	8	5
	27.5°	3	7	4

## 4.0 ELECTRICAL

### 4.1 General

All wiring and terminal blocks shall meet the requirements of Section 13.02 of the VTCSH standard. Two secured, color coded, 914 mm (36 in) long 600 V, 20 AWG minimum, jacketed wires, conforming to the National Electrical Code, rated for service at +105°C, are to be provided for electrical connection.

### 4.2 Voltage Range

4.2.1 LED arrows shall operate from a 60 ± 3 cycle ac line power over a voltage range from 80 Vac-rms to 135 Vac-rms. The current draw shall be sufficient to ensure compatibility and proper triggering and operation of

load current switches and conflict monitors in signal controller units the procuring traffic authority customer has in use.

**4.2.2** Nominal operating voltage for all measurements shall be  $120 \pm 3$  volts rms.

**4.2.3** Fluctuations in line voltage over the range of 80Vac to 135Vac shall not affect luminous intensity by more than  $\pm 10$  percent.

**4.2.4** The LED circuitry shall prevent flicker at less than 100 Hz over the voltage range specified in Section 4.2.1.

**4.2.5 Low Voltage Turn Off**

There shall be no illumination from the arrow when the applied voltage is less than 45 volts AC. To test for this condition the unit must first be fully illuminated at the nominal operating voltage. The applied voltage is then reduced to the point that there is no illumination. This point must be greater than 45 volts AC. The same requirement should apply in rising voltage from 0 to 45 with no visible illumination.

**4.2.6 Turn-On and Turn-Off Time:**

The modules shall reach 90% of their full illumination (turn-on) within 75 msec after the application of the nominal operating voltage. The arrows shall not be illuminated (turn-off) within 75 msec after the removal of the nominal operating voltage.

**4.3 Transient Voltage Protection**

**4.3.1** The arrow on-board circuitry shall include voltage surge protection to withstand high-repetition noise transients and low-repetition, high-energy transients as stated in Section 2.1.6, NEMA Standard TS-2, 1992.

**4.4 LED Drive Circuitry**

**4.4.1** The individual LED light sources shall be wired so that the catastrophic failure of one LED will result in the loss of the light from only that one LED.

**4.5 Electronic Noise**

The LED arrow and associated on-board circuitry must meet Federal Communications Commission (FCC) Title 47, SubPart B, Section 15 regulations concerning the emission of electronic noise.

**4.6 Power Factor (PF) and AC Harmonics**

**4.6.1** LED arrows shall provide a power factor of 0.90 or greater when operated at nominal operating voltage, and 25°C (77°F).

4.6.2 Total harmonic distortion induced into an ac power line by an LED arrow, at 25°C (77°F) shall not exceed 20 percent.

#### 4.7 Wattage

Proposed LED arrow modules shall be less than or equal to the base wattage shown below at 25 degrees C.

Type	Wattage
12" Red Arrow	5 or less
12" Yellow Arrow	10 or less
12" Green Arrow	5 or less

### 5.0 QUALITY ASSURANCE

#### 5.1 General

##### 5.1.1 Quality Management System

The LED signal manufacturer's quality management system shall be ISO 9001 registered.

##### 5.1.2 Quality Assurance Program

LED arrows shall be manufactured in accordance with a vendor quality assurance (QA) program. The QA program shall include two types of quality assurance: (1) design quality assurance, and (2) production quality assurance. The production quality assurance shall include statistically controlled routine tests to ensure minimum performance levels of LED arrows built to meet this specification.

##### 5.1.3 Record Keeping

QA process and test results documentation shall be kept on file for a minimum period of seven years.

##### 5.1.4 Conformance

LED arrows designs not satisfying design qualification testing and the production quality assurance testing performance requirements in Sections 5.3 and 5.4 shall not be labeled, advertised, or sold as conforming to this specification.

#### 5.2 Manufacturers Serial Numbers

Each LED arrow shall be identified by a manufacturer's serial number for warranty purposes.

#### 5.3 Production Quality Assurance (QA) Testing

All new LED arrows shall undergo the following Production Quality Assurance testing prior to shipment. Failure of any LED arrow to meet requirements of these QA tests shall be cause for rejection. QA test results shall be maintained per the requirement of Section 5.1.2.

#### **5.3.1 Production Luminous Intensity Test**

All arrows shall be tested for maintained minimum luminous intensity. A single point measurement with a correlation to the intensity requirements of Table 1 in Section 3.0 may be used.

#### **5.3.2 Power Factor**

All LED arrows shall be tested for power factor after burn-in per the requirements of Section 4.6.1. A commercially available power factor meter may be used to perform this measurement.

#### **5.3.3 Current**

All LED arrows shall be measured for the amount of current consumption. The measured current values shall be compared against current values resulting from design qualification measurements in Section 5.4.4.1. Measured current values in excess of 120 percent of the design qualification current values shall be cause for rejection.

#### **5.3.4 Visual Inspection**

All LED arrows shall be visually inspected for any exterior physical damage or assembly anomalies.

### **5.4 Design Qualification Testing**

Design qualification testing shall be performed on new LED signal module designs, and when a major design change has been implemented on an existing design. The minimum sample quantity of LED signal arrows shall be as stated for each test. Failure to meet requirements of any of these tests shall be cause for rejection.

Testing shall be performed once every 5 years or when the arrow design or LED technology has been changed. Test data shall be retained by the testing laboratory and the LED arrow manufacturer for a minimum period of 5 years.

#### **5.4.1 Burn-in**

LED arrows shall be energized for a minimum of 24 hours, at 100 percent on-time duty cycle, in an ambient temperature of +60°C (+140°F) before performing any design qualification testing. Any failure within an LED arrow after burn-in shall be cause for rejection.

#### **5.4.2 Maintained Minimum Luminous Intensity**

5.4.2.1 After burn-in, a random sample of six LED arrows shall be tested for maintained minimum luminous intensity at each of the 44 points indicated in Table 1, Section 3.0. These measurements shall be recorded at an ambient temperature of 25°C after the signal has been operated for 60 min.



5.4.2.2 After burn-in, a random sample of six LED arrows shall be tested for maintained minimum luminous intensity. Arrows to be tested shall be mounted in a temperature testing chamber so that the lensed portion of the arrow is outside the chamber and all portions behind the lens are within the chamber.

Red & Green Led Modules shall be tested for luminous output at 74°C, allowing the LED modules to achieve thermal equilibrium for 60 minutes, while the signal is energized at nominal operating voltage, at a 100% duty cycle. A single luminous intensity measurement shall be recorded.

A single point correlation measurement, accounting for measurement variables, shall be made at 25°C (77°F). For Red and green a measurement shall be made at 74°C (165°F) (lens at 49°C (120°F)). The 74°C measurement factored to the 25°C measurement shall be able to be correlated to the requirements of Table 1, Section 3.0. Arrows not meeting this correlation shall be cause for rejection.

#### **5.4.3 Chromaticity**

A sample of two LED arrows shall be measured for chromaticity per the requirements of Section 3.2. A spectroradiometer shall be used for this measurement. The ambient temperature for this measurement shall be +25°C (+77°F).

#### **5.4.4 Electrical**

**5.4.4.1 Current.** A sample of six LED arrows shall be measured for current flow in Amperes. The measured current values shall be used for quality comparison of Production Quality Assurance current measurements on production modules.

**5.4.4.2 Power Factor (PF).** A sample of six LED arrows shall be measured for power factor per the requirements of Section 4.6.1. A commercially available power factor meter may be used to perform this measurement.

**5.4.4.3 Total Harmonic Distortion (THD).** A sample of six LED arrows shall be measured for total harmonic distortion per the requirements of Section 4.6.2. A commercially available total harmonic distortion meter may be used to perform this measurement.

**5.4.4.4 Electronic Noise.** Sample of one LED arrow shall be tested per the requirements of Section 4.6, with reference to Class A emission limits referenced in Federal Communications Commission (FCC) Title 47, SubPart B, Section 15.

**5.4.4.5 Low Voltage Turn Off:** After burn-in a sample of six LED arrows shall be measured to meet the low voltage turn-off requirement of section 4.2.5.

**5.4.4.6 Turn-On and Turn-Off Times:** A sample of six LED arrows shall be measured to meet the turn-on and turn-off requirements of section 4.2.6.

**5.4.4.7 Controller Assembly Compatibility.** Due to the low load current draw and high off-state impedance of LED arrow, the following design qualification tests shall be performed to ensure the LED arrow design is compatible and operates properly with load current switches and conflict monitors in NEMA and Type 170 traffic signal control units.

**5.4.4.7.1 Load Switch Compatibility.** A sample of six LED arrows shall be tested for compatibility and proper operation with load current switches. Each LED arrow shall be connected to a variable ac voltage supply. The ac line current into the LED arrow shall be monitored for sufficient current draw to ensure proper load switch operation while the voltage is varied from 80 V rms to 135 V rms. Failure of the current draw to ensure proper load current switch operation shall be cause for rejection.

**5.4.4.7.2 Signal Conflict Monitor Compatibility.** A sample of six LED arrows shall be tested for compatibility and proper operation with signal conflict monitors. Each LED arrow shall be operated from a 135 V ac voltage supply. A 19.5 k $\Omega$  resistor shall be wired in series in the hot line between the LED monitor and the ac power supply. A single-pole-single-throw switch shall be wired in parallel across the 19.5 k $\Omega$  resistor. A 220 k $\Omega$  shunt resistor shall be wired between the hot line connection and the neutral line connection on the LED arrow. Conflict monitor compatibility shall be tested by measuring the voltage decay across the 200 k $\Omega$  shunt resistor as follows: The single-pole-single-throw switch shall be closed, shorting out the 19.5 k $\Omega$  resistor, allowing the ac power supply to illuminate the LED arrow. Next the switch shall be opened, and the voltage across the 220 k $\Omega$  shunt resistor shall be measured for a decay to a value equal to or less than 10V rms within a time period equal to or less than 100 milliseconds. This test shall be repeated a sufficient number of times to ensure testing occurs at the peak of the ac line voltage cycle.

A voltage decay across the 200 k $\Omega$  shunt resistor to a value greater than 10 V rms or a decay time to 10 V rms greater than 100 milliseconds shall be cause for rejection.

**5.4.4.8 Nondestruct Transient Immunity.** A sample of six LED arrows shall be tested for transient immunity using the procedure described in Section 2.1.8, NEMA Standard TS 2-1992.

## **5.4.5 Environment**

### **5.4.5.1 Mechanical vibration**

Mechanical vibration testing shall be performed on a sample of three LED arrows per MIL-STD-883, Test Method 2007, using three 4-minute cycles

along each x, y, and z axis, at a force of 2.5 Gs, with a frequency sweep from 2 Hz to 120 Hz. The loosening of the lens, of any internal components, or other physical damage shall be cause for rejection.

**5.4.6.2 Temperature Cycling.** Temperature cycling shall be performed on a sample of three LED arrows per MIL-STD-883, Test method 1010. The temperature range shall be per Section 2.3. A minimum of 20 cycles shall be performed with a 30-minute transfer time between temperature extremes and a 30-minute dwell time at each temperature. LED arrows test shall be non-operating. Failure of a LED arrow to function properly or any evidence of cracking of the LED arrow's lens or housing after temperature cycling shall be cause for rejection.

**5.4.6.3 Moisture Resistance.** Moisture resistance testing shall be performed on a sample of three LED arrows per NEMA Standard 250-1991 for Type 4 enclosures.

## 6.0 WARRANTY

**6.1** LED arrows shall be replaced or repaired if it fails to function as intended due to workmanship or material defects within the first 60 months from the date of delivery.

**6.2** LED arrows which exhibit luminous intensities less than the minimum values specified in Table 1 Section 3.0 within the first 60 months of the date of delivery shall be replaced or repaired.

This item will be paid for at the contract unit price each for LIGHT EMITTING DIODE (LED) SIGNAL FACE RETROFIT (ARROW INDICATIONS), and no other compensation will be allowed for any costs incurred.

### LIGHT EMITTING DIODE (LED) SIGNAL HEAD

Effective: April 1, 2002

Add the following paragraph to the end of Article 802.03 of the Standard Specifications:

"The warranty for light emitting diode (LED) modules, including the maintained minimum luminous intensities, shall cover a minimum of 60 months from the date of delivery."

Revise Article 880.01 of the Standard Specifications to read:

"880.01 Description. This work shall consist of furnishing and installing a conventional signal head, optically programmed signal head or light emitting diode (LED) signal head."

Revise Article 880.02(a) of the Standard Specifications to read:

"(a) Signal Heads.....1078.01"

Revise the first sentence of the first paragraph of Article 880.03 of the Standard Specifications to read:

"The signal head shall be installed on a post, bracket, span wire or mast arm as shown on the plans."

Revise the first paragraph of Article 880.04 of the Standard Specifications to read:

"880.04 Basis of Payment. This work will be paid for at the contract unit price each for SIGNAL HEAD, OPTICALLY PROGRAMMED SIGNAL HEAD, or SIGNAL HEAD, LED of the type specified and of the material type when specified."

Revise Article 1078.01 of the Standard Specifications to read:

"1078.01 Signal Head, Optically Programmed Signal Head and Light Emitting Diode (LED) Signal Head."

Add the following to Article 1078.01(c) of the Standard Specifications:

"(3) The LED signal section shall be according to the following:

**General Requirements.** The LED signal head shall meet the requirements of the Institute of Transportation Engineers (ITE) interim LED purchase specification, "Vehicle Traffic Control Signal Heads, Part 2: LED Vehicle Traffic Signal Modules", or applicable successor ITE specifications, except as modified herein. The LEDs utilized in the modules shall not be Aluminum Gallium Arsenide (AlGaAs) material technology.

**Physical and Mechanical Requirements.** The power supply for the LED module shall be integrated with the unit.

**Photometric Requirements.** The candlepower values for yellow 12-inch circular modules shall be equal to the corresponding values for green 12-inch circular modules as listed in Table 1 of Section 4 of the aforementioned ITE specification.

The illuminated portion of the arrow module shall be uniformly and completely dispersed with the LEDs.

**Electrical Requirements.** When applicable to the particular module type, the LED signal module shall be EPA Energy Star qualified. For yellow 12-inch circular and arrow modules, the wattage shall be as follows:

Module Type	Maximum Watts (W) At 74 °C (165 °F)	Nominal Watts (W) At 25 °C (77 °F)
12-inch Yellow Circular	25	22
12-inch Yellow Arrow	12	10

The LED module shall provide the failed state impedance as specified in ITE, VTCSH, Part 2.

**Warranty.** The LED modules shall be warranted according to Article 802.03. The maintained minimum intensities for 12-inch arrow modules throughout the warranty period under the operating temperature and voltage range, and at the end of the warranty period shall not be less than the following values:

Module Type	Maintained Minimum Intensities (cd/sq m)
Red Arrow	5,000
Yellow Arrow	11,000
Green Arrow	11,000

### **REMOVE EXISTING TRAFFIC SIGNAL EQUIPMENT**

The removal of existing traffic signal equipment shall be in accordance with Section 895.05 (a) of the Standard Specifications. This item shall be for the removal of the following traffic signal equipment at 20<sup>th</sup> and Madison Avenue:

#### **Northeast Corner**

- 1 Each Existing Service Installation from Wood Pole
- 1 Each 3-Face, 3-Section, Bracket Mounted Signal Head
- 1 Each 2-Face, Bracket Mounted Pedestrian Signal Head
- 1 Each Traffic Signal Post and Base

#### **Southeast Corner**

- 1 Each Pedestrian Signal Head (1 Face of a 2-Face Pedestrian Head)
- 2 Each 1-Face, 3-Section, Mast Arm Mounted Signal Heads

#### **Southwest Corner**

- 2 Each 1-Face Pedestrian Signal Head
- 1 Each 1-Face, 3-Section, Bracket Mounted Signal Head
- 1 Each 2-Face, 3-Section, Bracket Mounted Signal Head
- 2 Each Traffic Signal Post, and Base

#### **Northwest Corner**

- 1 Each 2-Face Pedestrian Signal Head
- 2 Each 1-Face, 3-Section, Mast Arm Mounted Signal Heads

The removed traffic signal equipment shall remain the property of the City of Granite City and shall be disposed of as directed by the Engineer.

Removal of existing traffic signal equipment will be paid for at the contract unit price each for REMOVE EXISTING TRAFFIC SIGNAL EQUIPMENT.

### **REMOVE EXISTING CONCRETE FOUNDATIONS**

The removal of existing concrete foundations shall be in accordance with Section 895.05 (c) of the Standard Specifications. This item shall be for the removal of TYPE A concrete traffic signal foundations at 20<sup>th</sup> and Madison Avenue:

Removal of existing concrete foundations will be paid for at the contract unit price each for REMOVE EXISTING CONCRETE FOUNDATION.

### **ADA PEDESTRIAN PUSH-BUTTON**

This work shall consist of furnishing and installing a pedestrian push-button in accordance with Sections 888 and 1074.02 of the Standard Specifications for Road and Bridge Construction and the following additions or exceptions.

Housing: The housing shall be made of a dense cross-linked polyethylene, which has been UV stabilized. The mounting screws and terminal screws shall be stainless steel.

Push-button: The push-button shall be made of the same material as the housing and meet ADA requirements for pedestrian crossing controls. The plunger shall be high visibility yellow. The switching action shall be achieved with a sealed permanent magnet and a sealed magnetic proximity switch, providing electrical isolation between the signal system and the pedestrian.

Basis of Payment: This work will be paid for at the contract unit price each for ADA PEDESTRIAN PUSH-BUTTON, which price shall be payment in full for furnishing and installing the pedestrian push-button to the satisfaction of the Engineer.

### **GEOMETRICALLY PROGRAMMED LOUVER**

This item shall consist of furnishing and installing a geometrically programmable louver for a 12-inch traffic signal head. The louver shall be constructed of a lightweight polycarbonate material compatible with polycarbonate traffic signal heads and visors.

The louver shall be both horizontally adjustable for sight distance control and vertically adjustable for lane control. The louver shall be adjustable for a 7 through 15-degree cut off angle.

This item shall be installed in the red section of the primary left turn signal indication.

This item will be paid for at the contract unit price each for GEOMETRICALLY PROGRAMMED LOUVER, which price shall include furnishing a geometrically programmable louver and installing and adjusting/programming the unit as directed by the Engineer in a traffic signal section as noted on the plans.

### **MODIFY EXISTING CONTROLLER**

This work shall consist of modifying an existing controller to operate as a full-traffic/pedestrian actuated controller using the same sequence of operation presently being run as pre-timed.

The existing controller is an Econolite Model ASC/2S-2100. The controller cabinet contains a wired loop detector rack. This work includes installing a loop detector power supply and the required number of loop detector amplifiers to provide full-traffic actuated operation as required by the sequence of operation table. Loop detectors are listed on the plans as separate pay items.

This work shall also include any modifications necessary to provide pedestrian phase actuation. The pedestrian "walk" indications shall be displayed only when an actuation is received from a pedestrian pushbutton.

This item will be paid for at the contract unit price each for MODIFY EXISTING CONTROLLER, which price shall include all necessary parts, labor and programming required to modify an existing controller to full-traffic/pedestrian actuated operation.

### **INTERSECTION TRAFFIC CONTROL DURING CONSTRUCTION**

The existing traffic signals at the intersection of 20<sup>th</sup> Street and Madison Avenue shall remain in operation as much as possible while this contract is in force. However, with the approval of the Engineer, the traffic signals may be turned off for a limited period to facilitate traffic signal reconstruction. The Contractor shall erect stop signs on all intersection approaches prior to turning the traffic signals off.

The Contractor shall plan work activities and provide the amount of workers and equipment necessary to facilitate returning the traffic signals to proper operation within the required time period. It will be the Contractor's responsibility to execute all work activities to include: removing traffic signal heads, posts and electric cable; installing new conduits, handholes, foundations, mast arm assemblies and poles, signal heads and electric cable so that the traffic signals can be returned to proper operation within 20 calendar days.

If the Contractor determines they cannot perform the required work within the guidelines established above, the Contractor may, at their own expense, install temporary span wire mounted traffic signal heads and electric cables to maintain the traffic signals in operation during construction.

This work shall be considered a requirement of this contract and no additional compensation shall be paid to the Contractor for maintaining all-way stop control for the limited shutdown period.

### **CONCRETE STAIRS REMOVAL**

This item of work shall consist of furnishing all labor, equipment and materials necessary to remove the existing concrete stairs located at Station 108+88.04, Rt. (20<sup>th</sup> Street). This work shall include the lawful removal and disposal of all of the related materials. This work shall also include the careful removal and stockpiling of the existing handrails that will be installed on the reconstructed concrete stairs at the same location.

This work shall be done in accordance with Section 500 of the Standard Specifications.

This work shall not be paid for separately but shall be included in the cost of CONCRETE STAIRS and no additional compensation or remuneration will be allowed.

## **CONCRETE STAIRS**

This item of work shall consist of furnishing all labor, equipment and materials necessary to construct concrete stairs located at Station 108+88.04, Rt. (20<sup>th</sup> Street) according to the details as shown in the plans. This work shall also include the installation of the salvaged handrails as outlined the special provision for CONCRETE STAIRS REMOVAL as included herein. The handrails shall be fastened to the proposed stairs with anchor bolts as approved by the Engineer.

This work shall be done in accordance with Section 503 of the Standard Specifications.

This work shall be paid at the contract unit price per Lump Sum for CONCRETE STAIRS and no additional compensation or remuneration will be allowed.

## **PROTECTION OF EXISTING RETAINING WALL**

The Contractor shall be aware when working in the area from Station 107+10.35, Rt. (20<sup>th</sup> Street) to Station 109+87.50, Rt. (20<sup>th</sup> Street), the existing block retaining wall shall be protected from damage. Any damage to the wall resulting from the Contractor's operations shall be repaired at his/her own expense to the satisfaction of the Engineer.

Compliance with this Special Provision shall be considered included in the cost of the contract and no additional compensation will be allowed for any costs incurred.

## **EMERGENCY SERVICES COORDINATION**

This contract work is within the corporate boundaries of the City of Granite City and includes work directly related to streets and roads. This work may compromise regular traffic flow.

Any time normal traffic flow is to be interrupted, however briefly, the Granite City Fire Department and Police Department must be advised. This is especially necessary when any street or road is completely impassable.

When the above scenario presents itself, contact the fire department at (618) 451-6231 and the police department at (618) 451-9760 to relay this information.

## **SEEDING CLASS 2**

This item shall consist of furnishing all labor and material to fertilize, seed and mulch all bare and disturbed areas in accordance with Sections 250 and 251 of the "Standard Specifications for Road and Bridge Construction".

This item shall be considered included in the contract and no additional compensation or remuneration will be allowed.



**STATUS OF UTILITIES TO BE ADJUSTED**

<u>Utility</u>	<u>Owner</u>	<u>Remarks</u>
Sanitary and Storm Sewers	City of Granite City 2000 Edison Avenue Granite City, IL 62040 (618) 452-6222	No Adjustment Anticipated (Inlets, Manholes, Sewers)
Water	Illinois-American Water Co. 100 North Water Works Drive P.O. Box 24020 Belleville, Illinois 62223 (618) 227-7450	To be Adjusted By July 1, 2005
Cable	Charter Communications 200 W. Division Street Maryville, IL 62062 (618) 345-8121	To be Adjusted By July 1, 2005
Gas Electric	Illinois Power Co. 2600 N. Center Street P.O. Box D Maryville, IL 62062 (800) 750-6890	To be Adjusted By July 1, 2005
Telephone	SBC 203 Goethe Collinsville, IL 62234 (618) 233-3191	To be Adjusted By July 1, 2005
Oxygen	Air Products Manufacturing Corp 2200 Monroe Avenue Granite City, IL 62040 (618) 452-5335	To Be Adjusted By July 1, 2005
Various	United States Steel Corporation 20 <sup>th</sup> and State Streets Granite City, IL 62040 (618) 451-3567	To Be Adjusted By July 1, 2005

**Required Contract Provisions  
All Contracts  
Monthly Labor Summary and Activity Reporting System**

Effective: 1-1-1995

Revised June 2001

**I. Monthly Labor Summary Report, Form SBE 148**

The prime contractor and each first and second tier sub-contractor, (hereinafter referred to as "subcontractor") shall submit a certified Monthly Labor Summary Report directly to the District Engineer.

This report is in lieu of submittal of the Monthly Workforce Analysis Report, Form SBE 956.

This report must be received in District Eight no later than the tenth day of the next month.

This Report shall be submitted by the prime contractor and each subcontractor, for each consecutive month, from the start, to the completion of their work on the contract.

The data source for this Report will be a summation of all personnel and hours worked on each subject contract for the month based on weekly payrolls for that month.

The Monthly Labor Summary Report is required to be submitted in one of the following formats:

- a.) For contractors having IDOT contracts valued in the aggregate at \$250,000 or less, the report may be typed or clearly handwritten using Form SBE 148 for submittal to the District Engineer for District Eight.
- b.) For contractors having IDOT contracts valued in the aggregate at more than \$250,000, the report must be submitted in a specific "Fixed Length Comma Delimited ASCII Text File Format". The subject file format is detailed on the next page. Submittal of this file may be by 3.5 inch disk, modem, or by e-mail.

**II. Monthly Contract Activity Report, Form SBE 248**

The prime contractor and each subcontractor shall submit a monthly report directly to the District Engineer, reflecting their contract activity on all Illinois Department of Transportation contracts they have in force in District Eight.

This report shall be submitted for each consecutive month, from the start, to the completion of all contracts in District Eight.

The report must be received in the District Office no later than the tenth day of the next month.

(1)

# Monthly Labor Summary and Activity Reporting System Codes and Formats

Indicated below for your reference are the Employee Codes and File Formats required for this system.

## I.) Monthly Labor Summary Report, Form SBE 148

The following employee codes are to be used to identify each individual on the Summary Report:

- |    |                      |                                    |                            |               |
|----|----------------------|------------------------------------|----------------------------|---------------|
| 1. | Gender:              | M - Male                           | F - Female                 |               |
| 2. | Ethnic Group:        | 1 - White                          | 2 - Black                  | 3 - Hispanic  |
|    |                      | 4 - American Indian/Alaskan Native | 5 - Asian/Pacific Islander |               |
| 3. | Work Classification: | OF - Official                      | SU - Supervisor            | FO - Foremen  |
|    |                      | CL - Clerical                      | EO - Operator              | ME - Mechanic |
|    |                      | TD - Truck Driver                  | PA - Painter               | OT - Other    |
|    |                      | EL - Electrician                   | TE - Technical             | LA - Laborer  |
|    |                      | CM - Cement Mason                  |                            |               |
| 4. | Employee Status:     | O - Owner Operator                 | J - Journeyman             | C - Company   |
|    |                      | A - Apprentice                     | T - Trainee                |               |

Specific "Fixed Length Comma Delimited ASCII File Format"

Order	Field Name	Type	Size
1	Contractor Number	A	4
2	Contractor Reference Number	A	6
3	Contract Number	A	5
4	Period (07/28/2000)	D	10
5	SSN (111-11-1111)	A	11
6	Name	A	40
7	Gender	A	1
8	Ethnic Group	A	1
9	Work Classification	A	1
10	Employee Status	A	1
11	Total Hours (0000060.00)	N	10

File Name Conventions: (Contractor Number + Report Month/Year).Txt  
i.e. 20001298.Txt

## II.) Monthly Contract Activity Report, Form SBE 248

The following activity codes are to be used to identify the contractors contract status each month on the Monthly Activity Report, Form SBE 248:

- A. Contract Status: 1 - Not Started 2 - Active 3 - No Work 4 - Suspended 5 - Complete

Failure to comply with this special provision may result in the withholding of payments to the contractor, and/or cancellation, termination, or suspension of the contract in whole or part.

Compliance with this Special Provision shall be considered incidental to the cost of the contract and no additional compensation will be allowed for any costs incurred.

All prime and subcontractors having contracts in the aggregate exceeding \$250,000 must provide a "Fixed Length Comma Delimited ASCII File" for approval prior to the start of construction.

This Special Provision must be included in each subcontract agreement.

monitor/molassp2

# REQUIRED CONTRACT PROVISIONS ALL CONTRACTS

## PAYROLLS and PROCEDURES

EFFECTIVE 2/5/1975, REVISED 11/7/1986, 1/14/1994, and June 2001

The prime contractor and each subcontractor shall submit a weekly certified original and one copy of their company's payroll directly to the District Engineer.

Payrolls must be received within seven days of the payroll ending period.

Payroll data shall be submitted on Payroll Form RE 48 or an approved facsimile.

Every person paid by a contractor or subcontractor in any manner for his or her labor in the construction, prosecution, completion, or repair of this public work is employed and receiving "wages", regardless of any contractual relationship alleged to exist between him or her and the real employer.

Payroll data shall include all persons employed on the job site.

The following employee codes are to be used to identify each individual on the payroll:

- |                         |                                    |                            |                    |
|-------------------------|------------------------------------|----------------------------|--------------------|
| A. Gender:              | M - Male                           | F - Female                 |                    |
| B. Ethnic Group:        | 1 - White                          | 2 - Black                  | 3 - Hispanic       |
|                         | 4 - American Indian/Alaskan Native | 5 - Asian/Pacific Islander |                    |
| C. Work Classification: | OF - Officials                     | SU - Supervisors           | FO - Foremen       |
|                         | CL - Clerical                      | EO - Operators             | ME - Mechanics     |
|                         | TD - Truck Drivers                 | PA - Painters              | CM - Cement Masons |
|                         | EL - Electricians                  | TE - Technical             | LA - Laborers      |
|                         | OT - Other                         |                            |                    |
| D. Employee Status:     | O - Owner Operator                 | J - Journeyman             | C - Company        |
|                         | A - Apprentice                     | T - Trainee                |                    |

Payroll data shall be submitted by the prime contractor and each subcontractor for each consecutive week, from the start to the completion of their work. When there has been no activity during a work week, a payroll is still required to be sent to the District Engineer, with the appropriate box ("No Work", "Suspended", "Completed") checked at the bottom of the Payroll Form RE 48. Do Not check any of these boxes when payroll data is being reported on the payroll.

The Department of Transportation is requesting disclosure of information necessary to accomplish the statutory purpose as outlined under 23CFR part 230 and 41CFR part 60.4 and the Illinois Human Rights Act. Disclosure of this information is REQUIRED. Failure to comply with this special provision may result in the withholding of payments to the contractor, and/or cancellation, termination, or suspension of the contract in whole or part.

Compliance with this Special Provision shall be considered incidental to the cost of the contract and no additional compensation will be allowed for any costs incurred.

This Special Provision must be included in each subcontract agreement.

State of Illinois  
Department of Transportation  
Bureau of Local Roads and Streets  
SPECIAL PROVISION  
FOR  
CONSTRUCTION AND MAINTENANCE SIGNS

Effective: January 1, 2004

All references to Sections or Articles in this specification shall be construed to mean a specific Section or Article of the Standard Specifications for Road and Bridge Construction, adopted by the Department of Transportation.

702.05 Signs. Add the following paragraph to subparagraph (a) in Article 702.05:

All warning signs shall have minimum dimensions of 1200 mm x 1200 mm (48" x 48") and have a black legend on a fluorescent orange reflectorized background, meeting, as a minimum, Type AP reflectivity requirements of Table 1091-2 in Article 1091.02.

## **BITUMINOUS CONCRETE SURFACE COURSE (BDE)**

Effective: April 1, 2001

Revised: April 1, 2003

Replace the fourth paragraph of Article 406.23(b) of the Standard Specifications with the following:

"Mixture for cracks, joints, flangeways, leveling binder (machine method), leveling binder (hand method) and binder course in excess of 103 percent of the quantity specified by the Engineer will not be measured for payment."

Surface course mixture in excess of 103 percent of adjusted plan quantity will not be measured for payment. The adjusted plan quantity for surface course mixtures will be calculated as follows:

Adjusted Plan Quantity = C x quantity shown on the plans or as specified by the Engineer.

where C =      metric:  $C = \frac{G_{mb} \times 24.99}{U}$               English:  $C = \frac{G_{mb} \times 46.8}{U}$

and where:

$G_{mb}$  = average bulk specific gravity from approved mix design.

U = Unit weight of surface course shown on the plans in kg/sq m/25 mm (lb/sq yd/in.), used to estimate plan quantity.

24.99 = metric constant.

46.8 = English constant.

If project circumstances warrant a new surface course mix design, the above equations shall be used to calculate the adjusted plan quantity for each mix design using its respective average bulk specific gravity."

80050

**BITUMINOUS EQUIPMENT, SPREADING AND FINISHING MACHINE (BDE)**

Effective: January 1, 2005

Revise the fourth paragraph of Article 1102.03 of the Standard Specifications to read:

“The paver shall be equipped with a receiving hopper having sufficient capacity for a uniform spreading operation. The hopper shall be equipped with a distribution system to uniformly place a non-segregated mixture in front of the screed. The distribution system shall have chain curtains, deflector plates, and /or other devices designed and built by the paver manufacturer to prevent segregation during distribution of the mixture from the hopper to the paver screed. The Contractor shall submit a written certification that the devices recommended by the paver manufacturer to prevent segregation have been installed and are operational. Prior to paving, the Contractor, in the presence of the Engineer, shall visually inspect paver parts specifically identified by the manufacturer for excessive wear and the need for replacement. The Contractor shall supply a completed check list to the Engineer noting the condition of the parts. Worn parts shall be replaced. The Engineer may require an additional inspection prior to placement of the surface course or at other times throughout the work.”

80142

**COARSE AGGREGATE FOR TRENCH BACKFILL, BACKFILL AND BEDDING (BDE)**

Effective: April 1, 2001  
Revised: November 1, 2003

Revise Article 208.02 of the Standard Specifications to read:

**"208.02 Materials.** Materials shall be according to the following Articles of Section 1000 – Materials:

- (a) Fine Aggregate (Note 1).....1003.04
- (b) Coarse Aggregate (Note 2) .....1004.06

Note 1. The fine aggregate shall be moist to the satisfaction of the Engineer.

Note 2. The coarse aggregate shall be wet to the satisfaction of the Engineer."

Revise the first sentence of the second paragraph of subparagraph (b) in Article 208.03 of the Standard Specifications to read:

"Any material meeting the requirements of Articles 1003.04 or 1004.06 which has been excavated from the trenches shall be used for backfilling the trenches."

Add the following to the end of Article 542.02 of the Standard Specifications:

- "(bb) Fine Aggregate (Note 1).....1003.04
- (cc) Coarse Aggregate (Note 2) .....1004.06

Note 1. The fine aggregate shall be moist to the satisfaction of the Engineer.

Note 2. The coarse aggregate shall be wet to the satisfaction of the Engineer."

Revise the first and second sentences of the second paragraph of subparagraph (a) of Article 542.04 of the Standard Specifications to read:

"The unstable and unsuitable material shall be removed to a depth determined by the Engineer and for a width of one diameter (or equivalent diameter) of the pipe on each side of the pipe culvert, and replaced with aggregate. Rock shall be removed to an elevation 300 mm (1 ft) lower than the bottom of the pipe or to a depth equal to 40 mm/m (1/2 in./ft) of ultimate fill height over the top of the pipe culvert, whichever is the greater depth, and for a width as specified in (b) below, and replaced with aggregate."



Revise the second paragraph of subparagraph (c) of Article 542.04 of the Standard Specifications to read:

"Well compacted aggregate, at least 100 mm (4 in.) in depth below the pipe culvert, shall be placed the entire width of the trench and for the length of the pipe culvert, except well compacted impervious material shall be used for the outer 1 m (3 ft) at each end of the pipe. When the trench has been widened by the removal and replacement of unstable or unsuitable material, the foundation material shall be placed for a width not less than the above specified widths on each side of the pipe. The aggregate and impervious material shall be approved by the Engineer and shall be compacted to the Engineer's satisfaction by mechanical means."

Revise subparagraph (e) of Article 542.04 of the Standard Specifications to read:

"(e) Backfilling. As soon as the condition of the pipe culvert will permit, the entire width of the trench shall be backfilled with aggregate to a height of at least the elevation of the center of the pipe. The aggregate shall be placed longitudinally along the pipe culvert, except at the outer 1 m (3 ft) at each end of the culvert which shall be backfilled with impervious material. The elevation of the backfill material on each side of the pipe shall be the same. The space under the pipe shall be completely filled. The aggregate and impervious material shall be placed in 200 mm (8 in.) layers, loose measurement. When using PVC, PE, or corrugated metal pipe, the aggregate shall be continued to a height of at least 300 mm (1 ft) above the top of the pipe and compacted to a minimum of 85 percent of standard lab density by mechanical means. When reinforced concrete pipes are used and the trench is within 600 mm (2 ft) of the pavement structure, the backfill shall be compacted to a minimum of 85 percent of standard lab density by mechanical means.

When using PVC, PE, or corrugated metal pipe a minimum of 300 mm (1 ft) of cover from the top of the pipe to the top of the subgrade will be required.

The installed pipe and its embedment shall not be disturbed when using movable trench boxes and shields, sheet pile, or other trench protection.

The remainder of the trench shall be backfilled with select material, from excavation or borrow, free from large or frozen lumps, clods or rock, meeting the approval of the Engineer. The material shall be placed in layers not exceeding 200 mm (8 in.) in depth, loose measurement and compacted to 95 percent of the standard laboratory density. Compaction shall be obtained by use of mechanical tampers or with approved vibratory compactors. Before compacting, each layer shall be wetted or dried to bring the moisture content within the limits of 80 to 110 percent of optimum moisture content determined according to AASHTO T 99 (Method C). All backfill material shall be deposited in the trench or excavation in such a manner as not to damage the culvert. The filling of the trench shall be carried on simultaneously on both sides of the pipe.

The Contractor may, at his/her expense, backfill the entire trench with aggregate in lieu of select material. The aggregate shall be compacted to the satisfaction of the Engineer by mechanical means.

The backfill material for all trenches and excavations made in the subgrade of the proposed improvement, and for all trenches outside of the subgrade where the inner edge of the trench is within 600 mm (2 ft) of the edge of the proposed pavement, curb, gutter, curb and gutter, stabilized shoulder, or sidewalk shall be according to Section 208. The trench backfill material shall be compacted to a minimum of 85 percent of standard lab density by mechanical means.

The Contractor may, at his/her expense, backfill the entire trench with controlled low strength material meeting the approval of the Engineer.

When the trench has been widened for the removal and replacement of unstable or unsuitable material, the backfilling with aggregate and impervious material, will be required for a width of at least the specified widths on each side of the pipe. The remaining width of each layer may be backfilled with select material. Each 200 mm (8 in.) layer for the entire trench width shall be completed before beginning the placement of the next layer."

Revise subparagraph (b) of Article 542.05 of the Standard Specifications to read:

"(b) Embankment. Embankment extending to an elevation of 300 mm (1 ft) over the top of the pipe shall be constructed according to Article 542.04(f), except the material up to the elevation of the center of the pipe and extending to a width of at least 450 mm (18 in.) on each side of the pipe, exclusive of the outer 1 m (3 ft) at each end of the pipe, shall consist of aggregate. At the outer 1 m (3 ft) at each end of the culvert, impervious material shall be used."

Add the following paragraph after the first paragraph of Article 542.10 of the Standard Specifications:

"Trench backfill will be measured for payment according to Article 208.03."

Add the following paragraph after the third paragraph of Article 542.11 of the Standard Specifications:

"Trench backfill will be paid for according to Article 208.04."

Add the following to of Article 550.02 of the Standard Specifications:

"(m) Fine Aggregate (Note 2).....	1003.04
(n) Coarse Aggregate (Note 3).....	1004.06

Note 2. The fine aggregate shall be moist to the satisfaction of the Engineer.

Note 3. The coarse aggregate shall be wet to the satisfaction of the Engineer."

Revise the first two sentences of the third paragraph of Article 550.04 of the Standard Specifications to read:

"Well compacted, aggregate bedding material at least 100 mm (4 in.) in depth below the pipe, shall be placed for the entire width of the trench and length of the pipe. The aggregate shall be compacted to the satisfaction of the Engineer by mechanical means."

Revise Article 550.07 of the Standard Specifications to read:

**"550.07 Backfilling.** As soon as the condition of the pipe will permit, the entire width of the trench shall be backfilled with aggregate to a height of at least the elevation of the center of the pipe. The aggregate shall be placed longitudinally along the pipe. The elevation of the backfill material on each side of the pipe shall be the same. The space under the pipe shall be completely filled. The aggregate backfill material shall be placed in 200 mm (8 in.) layers, loose measurement and compacted to the satisfaction of the Engineer by mechanical means. When using PVC pipe, the aggregate shall be continued to a height of at least 300 mm (12 in.) above the top of the pipe.

The installed pipe and its embedment shall not be disturbed when using movable trench boxes and shields, sheet pile, or other trench protection.

The remainder of the trench and excavation shall be backfilled to the natural line or finished surface as rapidly as the condition of the sewer will permit. The backfill material shall consist of suitable excavated material from the trench or of trench backfill as herein specified. All backfill material shall be deposited in the trench or excavation in such a manner as not to damage the sewer and shall be compacted to the satisfaction of the Engineer by mechanical means. The filling of the trench shall be carried on simultaneously on both sides of the pipe.

The backfill material for trenches and excavation made in the subgrade of the proposed improvement, and for all trenches outside of the subgrade where the inner edge of the trench is within 600 mm (2 ft) of the edge of the proposed pavement, curb, gutter, curb and gutter, stabilized shoulder or sidewalk shall be according to Section 208. The backfill material shall be compacted to 85 percent of standard lab density by mechanical means.

All backfill material up to a height of 300 mm (1 ft) above the pipe shall be deposited in uniform layers not exceeding 200 mm (8 in.) thick, loose measurement. The material in each layer shall be compacted to the satisfaction of the Engineer by mechanical means. The

backfilling above this height shall be done according to Method 1, 2 or 3 as described below, with the following exceptions.

When trench backfill or excavated material meeting the requirements of Section 208 is required above the first 300 mm (1 ft) of the pipe, the layers shall not exceed 200 mm (8 in.). Gradations CA6 or CA10 shall not be used with Method 2 or Method 3.

Method 1. The material shall be deposited in uniform layers not exceeding 300 mm (1 ft) thick, loose measurement, and each layer shall be compacted to the satisfaction of the Engineer by mechanical means.

Method 2. The material shall be deposited in uniform layers not exceeding 300 mm (1 ft) thick, loose measurement, and each layer shall be either inundated or deposited in water.

Method 3. The trench shall be backfilled with loose material, and settlement secured by introducing water through holes jetted into the backfill to a point approximately 600 mm (2 ft) above the top of the pipe. The holes shall be spaced as directed by the Engineer but shall be no farther than 2 m (6 ft) apart.

The water shall be injected at a pressure just sufficient to sink the holes at a moderate rate of speed. The pressure shall be such that the water will not cut cavities in the backfill material nor overflow the surface. If water does overflow the surface, it shall be drained into the jetted holes by means of shallow trenches.

Water shall be injected as long as it will be absorbed by the backfill material and until samples taken from test holes in the trench show a satisfactory moisture content. The Contractor shall bore the test holes not more than 15 m (50 ft) apart and at such other locations in the trench designated by the Engineer. As soon as the watersoaking has been completed, all holes shall be filled with soil and compacted by ramming with a tool approved by the Engineer.

Backfill material which has been watersoaked shall be allowed to settle and dry for at least 10 days before any surface course or pavement is constructed on it. The length of time may be altered, if deemed desirable, by the Engineer. Where the inner edge of the trench is within 600 mm (2 ft) of the edge of the proposed pavement, curb, gutter, curb and gutter, stabilized shoulder or sidewalk, the provisions of this paragraph shall also apply.

At the end of the settling and drying period, the crusted top of the backfill material shall be scarified and, if necessary, sufficient backfill material added, as specified in Method 1, to complete the backfilling operations.

The method used for backfilling and compacting the backfill material shall be the choice of the Contractor. If the method used does not produce results satisfactory to the Engineer, the Contractor will be required to alter or change the method being used so the resultant backfill will be satisfactory to the Engineer. Should the Contractor be required to alter or change the

method being used, no additional compensation will be allowed for altering or changing the method.

The Contractor may, at his/her expense, backfill the entire trench with controlled low strength material meeting the approval of the Engineer.

When sheeting and bracing have been used, sufficient bracing shall be left across the trench as the backfilling progresses to hold the sides firmly in place without caving or settlement. This bracing shall be removed as soon as practicable. Any depressions which may develop within the area involved in the construction operation due to settlement of the backfilling material shall be filled in a manner approved by the Engineer.

When the Contractor constructs the trench with sloped or benched sides according to Article 550.04, backfilling for the full width of the excavation shall be as specified, except no additional compensation will be allowed for trench backfill material required outside the vertical limits of the specified trench width.

Whenever excavation is made for installing sewer pipe across earth shoulders or private property, the topsoil disturbed by excavation operations shall be replaced as nearly as possible in its original position, and the whole area involved in the construction operations shall be left in a neat and presentable condition.

When using any PVC pipe, the pipe shall be backfilled with aggregate to 300 mm (1 ft) over the top of the pipe and compacted to a minimum of 85 percent of standard lab density by mechanical means.

When reinforced concrete pipes are used and the trench is within 600 mm (2 ft) of the pavement structure, the backfill shall be compacted to a minimum of 85 percent of standard lab density by mechanical means.

Deflection Testing for Storm Sewers. All PVC storm sewers will be tested for deflection not less than 30 days after the pipe is installed and the backfill compacted.

For PVC storm sewers with diameters 600 mm (24 in.) or smaller, a mandrel drag shall be used for deflection testing. For PVC storm sewers with diameters over 600 mm (24 in.), deflection measurements other than by a mandrel drag shall be used.

Where the mandrel is used, the mandrel shall be furnished by the Contractor and pulled by hand through the pipeline with a suitable rope or cable connected to each end. Winching or other means of forcing the deflection gauge through the pipeline will not be allowed.

The mandrel shall be of a shape similar to that of a true circle enabling the gauge to pass through a satisfactory pipeline with little or no resistance. The mandrel shall be of a design to prevent it from tipping from side to side and to prevent debris build-up from occurring between the channels of the adjacent fins or legs during operation. Each end of the core of the mandrel shall have fasteners to which the pulling cables can be attached. The mandrel shall have 9,

various sized fins or legs of appropriate dimension for various diameter pipes. Each fin or leg shall have a permanent marking that states its designated pipe size and percent of deflection allowable.

The outside diameter of the mandrel shall be 95 percent of the base inside diameter, where the base inside diameter is:

For all PVC pipe (as defined using ASTM D 3034 methodology):

If the pipe is found to have a deflection greater than specified, that pipe section shall be removed, replaced, and retested."

Revise subparagraph (c) of Article 1003.04 of the Standard Specifications to read:

"(c) Gradation. The fine aggregate gradation shall be as follows:

Backfill, bedding and trench backfill for pipe culverts and storm sewers .....	FA 1, FA 2, FA 6, or FA 21	
Porous granular embankment and backfill, french drains, and sand backfill for underdrains .....	FA 1, FA 2, or FA20 (Note 1)	

Note 1: For FA 1, FA 2, and FA 20 the percent passing the 75  $\mu$ m (No. 200) sieve shall be  $2 \pm 2$ ."

Revise the title of Article 1004.06 of the Standard Specifications to read:

**"Coarse Aggregate for Blotter, Embankment, Backfill, Trench Backfill, French Drains, and Bedding."**

Add the following to the end of subparagraph (c) of Article 1004.06 of the Standard Specifications:

"Backfill, bedding, and trench backfill for pipe culverts and storm sewers .....	CA 6, CA 10, and CA 18"
--	-------------------------

80051

## CONCRETE ADMIXTURES (BDE)

Effective: January 1, 2003

Revised: July 1, 2004

Revise Article 1020.05(b) of the Standard Specifications to read:

- "(b) Admixtures. Except as specified, the use of admixtures to increase the workability or to accelerate the hardening of the concrete will be permitted only when approved in writing by the Engineer. The Department will maintain an Approved List of Concrete Admixtures. When the Department permits the use of a calcium chloride accelerator, it shall be according to Article 442.02, Note 5.

When the atmosphere or concrete temperature is 18 °C (65 °F) or higher, a retarding admixture meeting the requirements of Article 1021.03 shall be used in the Class BD Concrete and portland cement concrete bridge deck overlays. The amount of retarding admixture to be used will be determined by the Engineer. The proportions of the ingredients of the concrete shall be the same as without the retarding admixture except that the amount of mixing water shall be reduced, as may be necessary, in order to maintain the consistency of the concrete as required. In addition, a high range water-reducing admixture shall be used in Class BD Concrete. The amount of high range water-reducing admixture will be determined by the Engineer. At the option of the Contractor, a water-reducing admixture may be used. Type I cement shall be used.

For Class PC and PS Concrete, a retarding admixture may be added to the concrete mixture when the concrete temperature is 18 °C (65 °F) or higher. Other admixtures may be used when approved by the Engineer, or if specified by the contract. If an accelerating admixture is permitted by the Engineer, it shall be the non-chloride type.

At the Contractor's option, admixtures in addition to an air-entraining admixture may be used for Class PP-1 concrete. The accelerator shall be the non-chloride type. If a water-reducing or retarding admixture is used, the cement factor may be reduced a maximum 18 kg/cu m (0.30 hundredweight/cu yd). If a high range water-reducing admixture is used, the cement factor may be reduced a maximum 36 kg/cu m (0.60 hundredweight/cu yd). Cement factor reductions shall not be cumulative when using multiple admixtures. An accelerator shall always be added prior to a high range water-reducing admixture, if both are used.

If Class C fly ash or ground granulated blast-furnace slag is used in Class PP-1 concrete, a water-reducing or high range water-reducing admixture shall be used. However, the cement factor shall not be reduced if a water-reducing, retarding, or high range water-reducing admixture is used. In addition, an accelerator shall not be used.

For Class PP-2 or PP-3 concrete, a non-chloride accelerator followed by a high range water-reducing admixture shall be used, in addition to the air-entraining admixture. For Class PP-3 concrete, the non-chloride accelerator shall be calcium nitrite.

For Class PP-2 or PP-3 concrete, the Contractor has the option to use a water-reducing admixture. A retarding admixture shall not be used unless approved by the Engineer. A water-reducing, retarding, or high range water-reducing admixture shall not be used to reduce the cement factor.

When the air temperature is less than 13 °C (55 °F) for Class PP-1 or PP-2 concrete, the non-chloride accelerator shall be calcium nitrite.

For Class PP-4 concrete, a high range water-reducing admixture shall be used in addition to the air-entraining admixture. The Contractor has the option to use a water-reducing admixture. An accelerator shall not be used. For stationary or truck mixed concrete, a retarding admixture shall be used to allow for haul time. The Contractor has the option to use a mobile portland cement concrete plant according to Article 1103.04, but a retarding admixture shall not be used unless approved by the Engineer. A water-reducing, retarding, or high range water-reducing admixture shall not be used to reduce the cement factor.

If the Department specifies a calcium chloride accelerator for Class PP-1 concrete, the maximum chloride dosage shall be 1.0 L (1.0 quart) of solution per 45 kg (100 lb) of cement. The dosage may be increased to a maximum 2.0 L (2.0 quarts) per 45 kg (100 lb) of cement if approved by the Engineer. If the Department specifies a calcium chloride accelerator for Class PP-2 concrete, the maximum chloride dosage shall be 1.3 L (1.3 quarts) of solution per 45 kg (100 lb) of cement. The dosage may be increased to a maximum 2.6 L (2.6 quarts) per 45 kg (100 lb) of cement if approved by the Engineer.

For Class PV, MS, SI, RR, SC and SH concrete, at the option of the Contractor, or when specified by the Engineer, a water-reducing admixture or a retarding admixture may be used. The amount of water-reducing admixture or retarding admixture permitted will be determined by the Engineer. The air-entraining admixture and other admixtures shall be added to the concrete separately, and shall be permitted to intermingle only after they have separately entered the concrete batch. The sequence, method and equipment for adding the admixtures shall be approved by the Engineer. The water-reducing admixture shall not delay the initial set of the concrete by more than one hour. Type I cement shall be used.

When a water-reducing admixture is added, a cement factor reduction of up to 18 kg/cu m (0.30 hundredweight/cu yd), from the concrete designed for a specific slump without the admixture, will be permitted for Class PV, MS, SI, RR, SC and SH concrete. When an approved high range water-reducing admixture is used, a cement factor reduction of up to 36 kg/cu m (0.60 hundredweight/cu yd), from a specific water cement/ratio without the admixture, will be permitted based on a 14 percent minimum water reduction. This is applicable to Class PV, MS, SI, RR, SC and SH concrete. A cement factor below 320 kg/cu m (5.35 hundredweight/cu yd) will not be permitted for Class PV, MS, SI, RR, SC and SH concrete. A cement factor reduction will not be



allowed for concrete placed underwater. Cement factor reductions shall not be cumulative when using multiple admixtures.

For use of admixtures to control concrete temperature, refer to Articles 1020.14(a) and 1020.14(b).

The maximum slumps given in Table 1 may be increased to 175 mm (7 in.) when a high range water-reducing admixture is used for all classes of concrete except Class PV and PP."

Revise Section 1021 of the Standard Specifications to read:

### **"SECTION 1021. CONCRETE ADMIXTURES**

**1021.01 General.** Admixtures shall be furnished in liquid form ready for use. The admixtures may be delivered in the manufacturer's original containers, bulk tank trucks or such containers or tanks as are acceptable to the Engineer. Delivery shall be accompanied by a ticket which clearly identifies the manufacturer and trade name of the material. Containers shall be readily identifiable to the satisfaction of the Engineer as to manufacturer and trade name of the material they contain.

Prior to inclusion of a product on the Department's Approved List of Concrete Admixtures, the manufacturer shall submit a report prepared by an independent laboratory accredited by the AASHTO Accreditation Program. The report shall show the results of physical tests conducted no more than five years prior to the time of submittal, according to applicable specifications.

Tests shall be conducted using materials and methods specified on a "test" concrete and a "reference" concrete, together with a certification that no changes have been made in the formulation of the material since the performance of the tests. Per the manufacturer's option, the cement content for all required tests shall either be according to applicable specifications or 335 kg/cu m (5.65 cwt/cu yd). Compressive strength test results for six months and one year will not be required.

In addition to the report, the manufacturer shall submit AASHTO T 197 water content and set time test results on the standard cement used by the Department. The test and reference concrete mixture shall contain a cement content of 335 kg/cu m (5.65 cwt/cu yd). The manufacturer may select their lab or an independent lab to perform this testing. The laboratory is not required to be accredited by the AASHTO Accreditation Program.

Prior to the approval of an admixture, the Engineer may conduct all or part of the applicable tests on a sample that is representative of the material to be furnished. The test and reference concrete mixtures tested by the Engineer will contain a cement content of 335 kg/cu m (5.65 cwt/cu yd). For freeze-thaw testing, the Department will perform the test according to Illinois Modified AASHTO T 161, Procedure B.

The manufacturer shall include in the submittal the following information according to ASTM C 494; the average and manufacturing range of specific gravity, the average and manufacturing range of solids in the solution, and the average and manufacturing range of pH. The submittal shall also include an infrared spectrophotometer trace no more than five years old.

When test results are more than seven years old, the manufacturer shall re-submit the infrared spectrophotometer trace and the report prepared by an independent laboratory accredited by the AASHTO Accreditation Program.

All admixtures, except chloride-based accelerators, shall contain no more than 0.3 percent chloride by mass (weight).

**1021.02 Air-Entraining Admixtures.** Air-entraining admixtures shall conform to the requirements of AASHTO M 154.

If the manufacturer certifies that the air-entraining admixture is an aqueous solution of Vinsol resin that has been neutralized with sodium hydroxide (caustic soda), testing for compliance with the requirements may be waived by the Engineer. In the certification, the manufacturer shall show complete information with respect to the formulation of the solution, including the number of parts of Vinsol resin to each part of sodium hydroxide. Before the approval of its use is granted, the Engineer will test the solution for its air-entraining quality in comparison with a solution prepared and kept for that purpose.

**1021.03 Retarding and Water-Reducing Admixtures.** The admixture shall comply with the following requirements:

- (a) The retarding admixture shall comply with the requirements of AASHTO M 194, Type B (retarding) or Type D (water-reducing and retarding).
- (b) The water-reducing admixture shall comply with the requirements of AASHTO M 194, Type A.
- (c) The high range water-reducing admixture shall comply with the requirements of AASHTO M 194, Type F (high range water-reducing) or Type G (high range water-reducing and retarding).

When a Type F or Type G high range water-reducing admixture is used, water-cement ratios shall be a minimum of 0.32.

Type F or Type G admixtures may be used, subject to the following restrictions:

For Class MS, SI, RR, SC and SH concrete, the water-cement ratio shall be a maximum of 0.44.

The Type F or Type G admixture shall be added at the jobsite unless otherwise directed by the Engineer. The initial slump shall be a minimum of 40 mm (1 1/2 in.)

prior to addition of the Type F or Type G admixture, except as approved by the Engineer.

When a Type F or Type G admixture is used, retempering with water or with a Type G admixture will not be allowed. An additional dosage of a Type F admixture, not to exceed 40 percent of the original dosage, may be used to retemper concrete once, provided set time is not unduly affected. A second retempering with a Type F admixture may be used for all classes of concrete except Class PP and SC, provided that the dosage does not exceed the dosage used for the first retempering, and provided that the set time is not unduly affected. No further retempering will be allowed.

Air tests shall be performed after the addition of the Type F or Type G admixture.

**1021.04 Set Accelerating Admixtures.** The admixture shall comply with the requirements of AASHTO M 194, Type C (accelerating) or Type E (water reducing and accelerating)"

80094

## **CURB RAMPS FOR SIDEWALK (BDE)**

Effective: January 1, 2004

Description. This work shall consist of constructing sidewalk curb ramps with detectable warnings in compliance with the Americans with Disabilities Act, Accessibility Guidelines (ADAAG). Work shall be according to Section 424 of the Standard Specifications except as modified herein.

The detectable warnings shall consist of an area of truncated domes that provide both visual and tactile cues to pedestrians who are about to enter into traffic. The warning area shall begin 150 mm (6 in.) from the back of the curb and continue 600 mm (2 ft) in the direction of pedestrian travel for the entire width of the walking surface.

The detectable warnings shall also present a contrast in color from the adjacent sidewalk. This shall be accomplished by constructing the warning area, plus the 150 mm (6 in.) area between the warning area and the back of curb, out of concrete that is integrally colored red. However if the sidewalk is brick or of some dark color, the contrast requirement shall be achieved with normal (grey), Class SI concrete.

Materials. Materials for the detectable warning area of the curb ramps shall meet the following requirements.

- a) **Integrally Colored Concrete.** Integrally colored concrete shall be according to Section 1020 of the Standard Specification for Class SI concrete except as follows.

- |                    |   |
|--------------------|---|
| Article 1020.04    | The allowable water/cement ratio range shall be 0.40 minimum to 0.44 maximum.   |
| Article 1020.04    | The allowable slump range shall be 75 mm (3 in.) minimum to 125 mm (5 in.) maximum.                                     |
| Article 1020.04    | The allowable coarse aggregate gradations shall be CA 11, CA 13, CA 14, and CA 16.                                      |
| Article 1020.05(b) | A calcium chloride accelerating admixture shall not be used.  |
| Article 1020.05(b) | The cement factor shall not be reduced if a water-reducing or high range water-reducing admixture is used.              |
| Article 1020.05(c) | Fly ash shall not be used.  |
| Article 1020.05(k) | Ground granulated blast-furnace slag shall not be used.   |
| Article 1020.11    | Pigment for integrally colored concrete shall be added to the concrete and mixed per the Manufacturer's recommendation. |

Article 1020.13 The curing method shall be Type I membrane curing.

Article 1020.13. The protection method shall be according to Article 1020.13(e)(1) and the protection period shall be 96 hours. No material, including the insulating material, shall be placed in direct contact with the concrete surface.

- (b) Pigment for Integrally Colored Concrete. The pigment shall meet the requirements of ASTM C 979, match color number 30166 of Federal Standard 595, and be on the Department's Approved List of Pigments for Integrally Colored Concrete.
- (c) Release Agent for Concrete Stamping Tools. The release agent shall be according to the stamping tool manufacturer's recommendations and the following: it shall be a clear liquid that will evaporate, it shall not harm the concrete, and it shall allow the application of Type I membrane curing.

Equipment. Equipment for the detectable warning area of the curb ramps shall meet the following requirements.

- (a) Concrete Stamps. Sufficient numbers and sizes of stamps shall be furnished to cover the various widths of the curb ramps. The stamps shall have an air opening at the top of each truncated dome recess; and shall be rigid enough to evenly distribute the force exerted during tamping.
- (b) Tamper. The tamper shall be according to the concrete stamp manufacturer's recommendations.

#### CONSTRUCTION REQUIREMENTS

Stamping. The concrete shall be placed and finished according to Article 424.06 except the area to be stamped shall not be brushed. When the bleed water has been absorbed, stamping shall begin. The entire width of the curb ramp shall be stamped at the same time. A single stamp or a combination of stamps may be used.

Prior to placing the stamp on the concrete, the stamp shall be coated with the release agent. When recommended by the manufacturer, the release agent shall also be applied to the concrete surface. Once the stamp has been placed on the ramp, it shall remain down until the stamping is complete.

The entire area of the stamp shall be tamped with a short, slow, repetitive action such that the concrete is caused to move up and into the dome recesses of the stamp. Tamping shall continue until mortar has come through the air openings in the stamp. Stepping or walking on the stamp will not be allowed. The base elevation of the domes shall be even with the adjacent sidewalk surface; the stamp shall not be forced down into the concrete.

When stamping is complete, the stamp shall be removed and the concrete cured.

Upon completion of curing, or after cold weather protection if required, the protruding mortar tip on the top of each dome shall be removed and the dome rubbed or ground smooth.

80113

## CURING AND PROTECTION OF CONCRETE CONSTRUCTION (BDE)

Effective: January 1, 2004

Revise the second and third sentences of the eleventh paragraph of Article 503.06 of the Standard Specifications to read:

"Forms on substructure units shall remain in place at least 24 hours. The method of form removal shall not result in damage to the concrete."

Delete the twentieth paragraph of Article 503.22 of the Standard Specifications.

Revise the "Unit Price Adjustments" table of Article 503.22 of the Standard Specifications to read:

"UNIT PRICE ADJUSTMENTS"	
Type of Construction	Percent Adjustment in Unit Price
For concrete in substructures, culverts (having a waterway opening of more than 1 sq m (10 sq ft)), pump houses, and retaining walls (except concrete pilings, footings and foundation seals):	
When protected by:	
Protection Method II	115%
Protection Method I	110%
For concrete in superstructures:	
When protected by:	
Protection Method II	123%
Protection Method I	115%
For concrete in footings:	
When protected by:	
Protection Method I, II or III	107%
For concrete in slope walls:	
When protected by:	
Protection Method I	107%

Delete the fourth paragraph of Article 504.05(a) of the Standard Specifications.

Revise the second and third sentences of the fifth paragraph of Article 504.05(a) of the Standard Specifications to read:

"All test specimens shall be cured with the units according to Article 1020.13."

Revise the first paragraph of Article 504.06(c)(6) of the Standard Specifications to read:

"Curing and Low Air Temperature Protection. The curing and protection for precast, prestressed concrete members shall be according to Article 1020.13 and this Article."

Revise the first sentence of the second paragraph of Article 504.06(c)(6) of the Standard Specifications to read:

“For curing, air vents shall be in place, and shall be so arranged that no water can enter the void tubes during the curing of the members.”

Revise the first sentence of the third paragraph of Article 504.06(c)(6) of the Standard Specifications to read:

“As soon as each member is finished, the concrete shall be covered with curing material according to Article 1020.13.”

Revise the eighth paragraph of Article 504.06(c)(6) of the Standard Specifications to read:

“The prestressing force shall not be transferred to any member before the concrete has attained the compressive strength of 28,000 kPa (4000 psi) or other higher compressive release strength specified on the plans, as determined from tests of 150 mm (6 in.) by 300 mm (12 in.) cylinders cured with the member according to Article 1020.13. Members shall not be shipped until 28-day strengths have been attained and members have a yard age of at least 4 days.”

Delete the third paragraph of Article 512.03(a) of the Standard Specifications.

Delete the last sentence of the second paragraph of Article 512.04(d) of the Standard Specifications.



Revise the "Index Table of Curing and Protection of Concrete Construction" table of Article 1020.13 of the Standard Specifications to read:

"INDEX TABLE OF CURING AND PROTECTION OF CONCRETE CONSTRUCTION"			
TYPE OF CONSTRUCTION	CURING METHODS	CURING PERIOD DAYS	LOW AIR TEMPERATURE PROTECTION METHODS
<b>Cast-in-Place Concrete:</b> <sup>11/</sup>			
Pavement			
Shoulder	1020.13(a)(1)(2)(3)(4)(5) <sup>3/5/</sup>	3	1020.13(c)
Base Course			
Base Course Widening	1020.13(a)(1)(2)(3)(4)(5) <sup>1/2/</sup>	3	1020.13(c)
Driveway			
Median			
Curb			
Gutter	1020.13(a)(1)(2)(3)(4)(5) <sup>4/5/</sup>	3	1020.13(c) <sup>16/</sup>
Curb and Gutter			
Sidewalk			
Slope Wall			
Paved Ditch			
Catch Basin			
Manhole	1020.13(a)(1)(2)(3)(4)(5) <sup>4/</sup>	3	1020.13(c)
Inlet			
Valve Vault			
Pavement Patching	1020.13(a)(1)(2)(3)(4)(5) <sup>2/</sup>	3 <sup>12/</sup>	1020.13(c)
Pavement Replacement	1020.13(a)(1)(2)(3)(4)(5) <sup>1/2/</sup>	3	442.06(h) and 1020.13(c)
Railroad Crossing	1020.13(a)(3)(5)	1	1020.13(c)
Piles	1020.13(a)(3)(5)	7	1020.13(e)(1)(2)(3)
Footings			
Foundation Seals	1020.13(a)(1)(2)(3)(4)(5) <sup>4/6/</sup>	7	1020.13(e)(1)(2)(3)
Substructure	1020.13(a)(1)(2)(3)(4)(5) <sup>17/</sup>	7	1020.13(e)(1)(2)(3)
Superstructure (except deck)	1020.13(a)(1)(2)(3)(5) <sup>8/</sup>	7	1020.13(e)(1)(2)
Deck	1020.13(a)(5)	7	1020.13(e)(1)(2) <sup>17/</sup>
Retaining Walls	1020.13(a)(1)(2)(3)(4)(5) <sup>17/</sup>	7	1020.13(e)(1)(2)
Pump Houses	1020.13(a)(1)(2)(3)(4)(5) <sup>1/</sup>	7	1020.13(e)(1)(2)
Culverts	1020.13(a)(1)(2)(3)(4)(5) <sup>4/6/</sup>	7	1020.13(e)(1)(2) <sup>18/</sup>
Other Incidental Concrete	1020.13(a)(1)(2)(3)(5)	3	1020.13(c)
<b>Precast Concrete:</b> <sup>11/</sup>			
Bridge Beams			
Piles			
Bridge Slabs	1020.13(a)(3)(5) <sup>9/10/</sup>	As required. <sup>13/</sup>	504.06(c)(6), 1020.13(e)(2) <sup>19/</sup>
Nelson Type Structural Member			
All Other Precast Items	1020.13(a)(3)(4)(5) <sup>2/9/10/</sup>	As required. <sup>14/</sup>	504.06(c)(6), 1020.13(e)(2) <sup>19/</sup>
<b>Precast, Prestressed Concrete:</b> <sup>11/</sup>			
All Items	1020.13(a)(3)(5) <sup>9/10/</sup>	Until strand tensioning is released. <sup>15/</sup>	504.06(c)(6), 1020.13(e)(2) <sup>19/</sup>

Notes-General:

- 1/ Type I, membrane curing only
- 2/ Type II, membrane curing only
- 3/ Type III, membrane curing only
- 4/ Type I, II and III membrane curing
- 5/ Membrane curing will not be permitted between November 1 and April 15.
- 6/ The use of water to inundate footings, foundation seals or the bottom slab of culverts is permissible when approved by the Engineer, provided the water temperature can be maintained at 7 °C ( 45 °F) or higher.
- 7/ Asphalt Emulsion for Waterproofing may be used in lieu of other curing methods when specified and permitted according to Article 503.18.
- 8/ On non-traffic surfaces which receive protective coat according to Article 503.19, a linseed oil emulsion curing compound may be used as a substitute for protective coat and other curing methods. The linseed emulsion curing compound will be permitted between April 16 and October 31 of the same year, provided it is applied with a mechanical sprayer according to Article 1101.09 (b), and meets the material requirements of Article 1022.07.
- 9/ Steam curing (heat and moisture) is acceptable and shall be accomplished by the method specified in Article 504.06(c)(6).
- 10/ A moist room according to AASHTO M 201 is acceptable for curing.
- 11/ If curing is required and interrupted because of form removal for cast-in-place concrete items, precast concrete products, or precast prestressed concrete products, the curing shall be resumed within two hours from the start of the form removal.
- 12/ Curing maintained only until opening strength is attained, with a maximum curing period of three days.
- 13/ The curing period shall end when the concrete has attained the mix design strength. The producer has the option to discontinue curing when the concrete has attained 80 percent of the mix design strength or after seven days. All strength test specimens shall remain with the units and shall be subjected to the same curing method and environmental condition as the units, until the time of testing.
- 14/ The producer shall determine the curing period or may elect to not cure the product. All strength test specimens shall remain with the units and shall be subjected to the same curing method and environmental condition as the units, until the time of testing.
- 15/ The producer has the option to continue curing after strand release.
- 16/ When structural steel or structural concrete is in place above slope wall, Article 1020.13(c) shall not apply. The protection method shall be according to Article 1020.13(e)(1).
- 17/ When Article 1020.13(e)(2) is used to protect the deck, the housing may enclose only the bottom and sides. The top surface shall be protected according to Article 1020.13(e)(1).
- 18/ For culverts having a waterway opening of 1 sq m (10 sq ft) or less, the culverts may be protected according to Article 1020.13(e)(3).
- 19/ The seven day protection period in the first paragraph of Article 1020.13(e)(2) shall not apply. The protection period shall end when curing is finished. For the third paragraph of Article 1020.13(e)(2), the decrease in temperature shall be according to Article 504.06(c)(6)."

Add the following to Article 1020.13(a) of the Standard Specifications:

"(5) Wetted Cotton Mat Method. After the surface of concrete has been textured or finished, it shall be covered immediately with dry cotton mats. The cotton mats shall be placed in a manner which will not mar the concrete surface. A texture resulting from the cotton mat material is acceptable. The cotton mats shall then be wetted immediately and thoroughly soaked with a gentle spray of water. For bridge decks, a foot bridge shall be used to place and wet the cotton mats.

The cotton mats shall be maintained in a wetted condition until the concrete has hardened sufficiently to place soaker hoses without marring the concrete surface. The soaker hoses shall be placed on top of the cotton mats at a maximum 1.2 m (4 ft) spacing. The cotton mats shall be kept wet with a continuous supply of water for the remainder of the curing period. Other continuous wetting systems may be used if approved by the Engineer.

After placement of the soaker hoses, the cotton mats shall be covered with white polyethylene sheeting or burlap-polyethylene blankets.

For construction items other than bridge decks, soaker hoses or a continuous wetting system will not be required if the alternative method keeps the cotton mats wet. Periodic wetting of the cotton mats is acceptable.

For areas inaccessible to the cotton mats on bridge decks, curing shall be according to Article 1020.13(a)(3)."

Revise the first paragraph of Article 1020.13(c) of the Standard Specifications to read:

"Protection of Portland Cement Concrete, Other Than Structures, From Low Air Temperatures. When the official National Weather Service forecast for the construction area predicts a low of 0 °C (32 °F), or lower, or if the actual temperature drops to 0 °C (32 °F), or lower, concrete less than 72 hours old shall be provided at least the following protection:"

Delete Article 1020.13(d) and Articles 1020.13(d)(1),(2),(3),(4) of the Standard Specifications.

Revise the first five paragraphs of Article 1020.13(e) of the Standard Specifications to read:

"Protection of Portland Cement Concrete Structures From Low Air Temperatures. When the official National Weather Service Forecast for the construction area predicts a low below 7 °C (45 °F), or if the actual temperature drops below 7 °C (45 °F), concrete less than 72 hours old shall be provided protection. Concrete shall also be provided protection when placed during the winter period of December 1 through March 15. Concrete shall not be placed until the materials, facilities and equipment for protection are approved by the Engineer.

When directed by the Engineer, the Contractor may be required to place concrete during the winter period. If winter construction is specified, the Contractor shall proceed with the construction, including concrete, excavation, pile driving, steel erection and all appurtenant work required for the complete construction of the item, except at times when weather conditions make such operations impracticable.

Regardless of the precautions taken, the Contractor shall be responsible for protection of the concrete placed and any concrete damaged by cold temperatures shall be removed and replaced by the Contractor at his/her own expense."

Add the following at the end of the third paragraph of Article 1020.13(e)(1) of the Standard Specifications:

"The Contractor shall provide means for checking the temperature of the surface of the concrete during the protection period."

Revise the second sentence of the first paragraph of Article 1020.13(e)(2) of the Standard Specifications to read:

"The Contractor shall provide means for checking the temperature of the surface of the concrete or air temperature within the housing during the protection period."

Delete the last sentence of the first paragraph of Article 1020.13(e)(3) of the Standard Specifications.

Add the following Article to Section 1022 of the Standard Specifications:

**"1022.06 Cotton Mats.** Cotton mats shall consist of a cotton fill material, minimum 400 g/sq m (11.8 oz/sq yd), covered with unsized cloth or burlap, minimum 200 g/sq m (5.9 oz/sq yd), and be tufted or stitched to maintain stability.

Cotton mats shall be in a condition satisfactory to the Engineer. Any tears or holes in the mats shall be repaired.

Add the following Article to Section 1022 of the Standard Specifications:

**"1022.07 Linseed Oil Emulsion Curing Compound.** Linseed oil emulsion curing compound shall be composed of a blend of boiled linseed oil and high viscosity, heavy bodied linseed oil emulsified in a water solution. The curing compound shall meet the requirements of a Type I, II, or III according to Article 1022.01, except the drying time requirement will be waived. The oil phase shall be 50 ± 4 percent by volume. The oil phase shall consist of 80 percent by mass (weight) boiled linseed oil and 20 percent by mass (weight ) Z-8 viscosity linseed oil. The water phase shall be 50 ± 4 percent by volume."

Revise Article 1020.14 of the Standard Specifications to read:

**"1020.14 Temperature Control for Placement.** Temperature control for concrete placement shall conform to the following requirements:

- (a) Temperature Control other than Structures. The temperature of concrete immediately before placing, shall be not less than 10 °C (50 °F) nor more than 32 °C (90 °F). Aggregates and/or water shall be heated or cooled as necessary to produce concrete within these temperature limits.

When the temperature of the plastic concrete reaches 30 °C (85 °F), an approved retarding admixture shall be used or the approved water reducing admixture in use shall have its dosage increased by 50 percent over the dosage recommended on the Department's Approved List of Concrete Admixtures for the temperature experienced. The amount of retarding admixture to be used will be determined by the Engineer. This requirement may be waived by the Engineer when fly ash compensated mixtures are used.

Plastic concrete temperatures up to 35 °C (96 °F), as placed, may be permitted provided job site conditions permit placement and finishing without excessive use of water on and/or overworking of the surface. The occurrence within 24 hours of unusual surface distress shall be cause to revert to a maximum 32 °C (90 °F) plastic concrete temperature.

Concrete shall not be placed when the air temperature is below 5 °C (40 °F) and falling or below 2 °C (35 °F), without permission of the Engineer. When placing of concrete is authorized during cold weather, the Engineer may require the water and/or the aggregates to be heated to not less than 20 °C (70 °F) nor more than 65 °C (150 °F). The aggregates may be heated by either steam or dry heat prior to being placed in the mixer. The apparatus used shall heat the mass uniformly and shall be so arranged as to preclude the possible occurrence of overheated areas which might damage the materials. No frozen aggregates shall be used in the concrete.

For pavement patching, refer to Article 442.06(e) for additional information on temperature control for placement.

- (b) Temperature Control for Structures. The temperature of concrete as placed in the forms shall be not less than 10 °C (50 °F) nor more than 32 °C (90 °F). Aggregates and/or water shall be heated or cooled as necessary to produce concrete within these temperature limits. When insulated forms are used, the temperature of the concrete mixture shall not exceed 25 °C (80 °F). If the Engineer determines that heat of hydration might cause excessive temperatures in the concrete, the concrete shall be placed at a temperature between 10 °C (50 °F) and 15 °C (60 °F), per the Engineer's instructions. When concrete is placed in contact with previously placed concrete, the temperature of the concrete may be increased as required to offset anticipated heat loss.

Concrete shall not be placed when the air temperature is below 7 °C (45 °F) and falling or below 4 °C (40 °F), without permission of the Engineer. When placing of concrete is

authorized during cold weather, the Engineer may require the water and/or the aggregates to be heated to not less than 20 °C (70 °F) nor more than 65 °C (150 °F). The aggregates may be heated by either steam or dry heat prior to being placed in the mixer. The apparatus used shall heat the mass uniformly and shall be so arranged as to preclude the possible occurrence of overheated areas which might damage the materials. No frozen aggregates shall be used in the concrete.

When the temperature of the plastic concrete reaches 30 °C (85 °F), an approved retarding admixture shall be used or the approved water reducing admixture in use shall have its dosage increased by 50 percent over the dosage recommended on the Department's Approved List of Concrete Admixtures for the temperature experienced. The amount of retarding admixture to be used will be determined by the Engineer. This requirement may be waived by the Engineer when fly ash compensated mixtures are used.

- (c) Temperature. The concrete temperature shall be determined according to ASTM C 1064."

80114

## **DISADVANTAGED BUSINESS ENTERPRISE PARTICIPATION (BDE)**

Effective: September 1, 2000

Revised: June 1, 2004

FEDERAL OBLIGATION. The Department of Transportation, as a recipient of federal financial assistance, is required to take all necessary and reasonable steps to ensure nondiscrimination in the award and administration of contracts. Consequently, the federal regulatory provisions of 49 CFR part 26 apply to this contract concerning the utilization of disadvantaged business enterprises. This Special Provision will also be used by the Department to satisfy the requirements of the Business Enterprise for Minorities, Females, and Persons with Disabilities Act, 30 ILCS 575. For the purposes of this Special Provision, a disadvantaged business enterprise (DBE) means a business certified by the Department in accordance with the requirements of 49 CFR part 26 and listed in the DBE Directory or most recent addendum.

CONTRACTOR ASSURANCE. The Contractor makes the following assurance and agrees to include the assurance in each subcontract that the Contractor signs with a subcontractor:

The contractor, subrecipient or subcontractor shall not discriminate on the basis of race, color, national origin, or sex in the performance of this contract. The contractor shall carry out applicable requirements of 49 CFR part 26 in the award and administration of federally-assisted contracts. Failure by the contractor to carry out these requirements is a material breach of this contract, which may result in the termination of this contract or such other remedy as the recipient deems appropriate.

OVERALL GOAL SET FOR THE DEPARTMENT. As a requirement of compliance with 49 CFR part 26, the Department has set an overall goal for DBE participation in its federally assisted contracts. That goal applies to all federal-aid funds the Department will expend in its federally assisted contracts for the subject reporting fiscal year. The Department is required to make a good faith effort to achieve the overall goal. The dollar amount paid to all approved DBE firms performing work called for in this contract is eligible to be credited toward fulfillment of the Department's overall goal.

CONTRACT GOAL TO BE ACHIEVED BY THE CONTRACTOR. This contract includes a specific DBE utilization goal established by the Department. The goal has been included because the Department has determined that the work of this contract has subcontracting opportunities that may be suitable for performance by DBE companies. This determination is based on an assessment of the type of work, the location of the work, and the availability of DBE companies to do a part of the work. The assessment indicates that, in the absence of unlawful discrimination, and in an arena of fair and open competition, DBE companies can be expected to perform 16 % of the work. This percentage is set as the DBE participation goal for this contract. Consequently, in addition to the other award criteria established for this contract, the Department will award this contract to a bidder who makes a good faith effort to meet this goal of DBE participation in the performance of the work. A bidder makes a good faith effort for award consideration if either of the following is done in accordance with the procedures set forth in this Special Provision:

- (a) The bidder documents that firmly committed DBE participation has been obtained to meet the goal; or
- (b) The bidder documents that a good faith effort has been made to meet the goal, even though the effort did not succeed in obtaining enough DBE participation to meet the goal.

DBE LOCATOR REFERENCES. Bidders may consult the DBE Directory as a reference source for DBE companies certified by the Department. In addition, the Department maintains a letting and item specific DBE locator information system whereby DBE companies can register their interest in providing quotes on particular bid items advertised for letting. Information concerning DBE companies willing to quote work for particular contracts may be obtained by contacting the Department's Bureau of Small Business Enterprises at telephone number (217)785-4611, or by visiting the Department's web site at [www.dot.state.il.us](http://www.dot.state.il.us).

BIDDING PROCEDURES. Compliance with the bidding procedures of this Special Provision is required prior to the award of the contract and the failure of the as-read low bidder to comply will render the bid nonresponsive.

- (a) In order to assure the timely award of the contract, the as-read low bidder must submit a Disadvantaged Business Utilization Plan on Department form SBE 2026 within seven (7) working days after the date of letting. To meet the seven (7) day requirement, the bidder may send the Plan by certified mail or delivery service within the seven (7) working day period. If a question arises concerning the mailing date of a Plan, the mailing date will be established by the U.S. Postal Service postmark on the original certified mail receipt from the U.S. Postal Service or the receipt issued by a delivery service. It is the responsibility of the as-read low bidder to ensure that the postmark or receipt date is affixed within the seven (7) working days if the bidder intends to rely upon mailing or delivery to satisfy the submission day requirement. The Plan is to be submitted to the Department of Transportation, Bureau of Small Business Enterprises, Contract Compliance Section, 2300 South Dirksen Parkway, Room 319, Springfield, Illinois 62764 (Telefax: (217)785-1524). It is the responsibility of the bidder to obtain confirmation of telefax delivery. The Department will not accept a Utilization Plan if it does not meet the seven (7) day submittal requirement, and the bid will be declared nonresponsive. In the event the bid is declared nonresponsive due to a failure to submit a Plan or failure to comply with the bidding procedures set forth herein, the Department may elect to cause the forfeiture of the penal sum of the bidder's proposal guaranty, and may deny authorization to bid the project if re-advertised for bids. The Department reserves the right to invite any other bidder to submit a Utilization Plan at any time for award consideration or to extend the time for award.
- (b) The Utilization Plan shall indicate that the bidder either has obtained sufficient DBE participation commitments to meet the contract goal or has not obtained enough DBE participation commitments in spite of a good faith effort to meet the goal. The Utilization Plan shall further provide the name, telephone number and telefax number of a



responsible official of the bidder designated for purposes of notification of plan approval or disapproval under the procedures of this Special Provision.

(c) The Utilization Plan shall include a DBE Participation Commitment Statement, Department form SBE 2025, for each DBE proposed for the performance of work to achieve the contract goal. The signatures on these forms must be original signatures. All elements of information indicated on the said form shall be provided, including but not limited to the following:

- (1) The name and address of each DBE to be used;
- (2) A description, including pay item numbers, of the commercially useful work to be done by each DBE;
- (3) The price to be paid to each DBE for the identified work specifically stating the quantity, unit price and total subcontract price for the work to be completed by the DBE. If partial pay items are to be performed by the DBE, indicate the portion of each item, a unit price where appropriate and the subcontract price amount;
- (4) A commitment statement signed by the bidder and each DBE evidencing availability and intent to perform commercially useful work on the project; and
- (5) If the bidder is a joint venture comprised of DBE firms and non-DBE firms, the plan must also include a clear identification of the portion of the work to be performed by the DBE partner(s).

(d) The contract will not be awarded until the Utilization Plan submitted by the bidder is approved. The Utilization Plan will be approved by the Department if the Plan commits sufficient commercially useful DBE work performance to meet the contract goal. The Utilization Plan will not be approved by the Department if the Plan does not commit sufficient DBE performance to meet the contract goal unless the bidder documents that it made a good faith effort to meet the goal. The good faith procedures of Section VIII of this special provision apply. If the Utilization Plan is not approved because it is deficient in a technical matter, unless waived by the Department, the bidder will be notified and will be allowed no less than a five (5) working day period in order to cure the deficiency.

CALCULATING DBE PARTICIPATION. The Utilization Plan values represent work anticipated to be performed and paid for upon satisfactory completion. The Department is only able to count toward the achievement of the overall goal and the contract goal the value of payments made for the work actually performed by DBE companies. In addition, a DBE must perform a commercially useful function on the contract to be counted. A commercially useful function is generally performed when the DBE is responsible for the work and is carrying out its responsibilities by actually performing, managing, and supervising the work involved. The Department and Contractor are governed by the provisions of 49 CFR part 26.55(c) on questions of commercially useful functions as it affects the work. Specific counting guidelines

are provided in 49 CFR part 26.55, the provisions of which govern over the summary contained herein.

- (a) DBE as the Contractor: 100% goal credit for that portion of the work performed by the DBE's own forces, including the cost of materials and supplies. Work that a DBE subcontracts to a non-DBE firm does not count toward the DBE goals.
- (b) DBE as a joint venture Contractor: 100% goal credit for that portion of the total dollar value of the contract equal to the distinct, clearly defined portion of the work performed by the DBE's own forces.
- (c) DBE as a subcontractor: 100% goal credit for the work of the subcontract performed by the DBE's own forces, including the cost of materials and supplies, excluding the purchase of materials and supplies or the lease of equipment by the DBE subcontractor from the prime contractor or its affiliates. Work that a DBE subcontractor in turn subcontracts to a non-DBE firm does not count toward the DBE goal.
- (d) DBE as a trucker: 100% goal credit for trucking participation provided the DBE is responsible for the management and supervision of the entire trucking operation for which it is responsible. At least one truck owned, operated, licensed and insured by the DBE must be used on the contract. Credit will be given for the full value of all such DBE trucks operated using DBE employed drivers. Goal credit will be limited to the value of the reasonable fee or commission received by the DBE if trucks are leased from a non-DBE company.
- (e) DBE as a material supplier:
  - (1) 60% goal credit for the cost of the materials or supplies purchased from a DBE regular dealer.
  - (2) 100% goal credit for the cost of materials or supplies obtained from a DBE manufacturer.
  - (3) 100% credit for the value of reasonable fees and commissions for the procurement of materials and supplies if not a regular dealer or manufacturer.

GOOD FAITH EFFORT PROCEDURES. If the bidder cannot obtain sufficient DBE commitments to meet the contract goal, the bidder must document in the Utilization Plan the good faith efforts made in the attempt to meet the goal. This means that the bidder must show that all necessary and reasonable steps were taken to achieve the contract goal. Necessary and reasonable steps are those which could reasonably be expected to obtain sufficient DBE participation. The Department will consider the quality, quantity and intensity of the kinds of efforts that the bidder has made. Mere *pro forma* efforts are not good faith efforts; rather, the bidder is expected to have taken those efforts that would be reasonably expected of a bidder actively and aggressively trying to obtain DBE participation sufficient to meet the contract goal.

- (a) The following is a list of types of action that the Department will consider as part of the evaluation of the bidder's good faith efforts to obtain participation. These listed factors are not intended to be a mandatory checklist and are not intended to be exhaustive. Other factors or efforts brought to the attention of the Department may be relevant in appropriate cases, and will be considered by the Department.
- (1) Soliciting through all reasonable and available means (e.g. attendance at pre-bid meetings, advertising and/or written notices) the interest of all certified DBE companies that have the capability to perform the work of the contract. The bidder must solicit this interest within sufficient time to allow the DBE companies to respond to the solicitation. The bidder must determine with certainty if the DBE companies are interested by taking appropriate steps to follow up initial solicitations.
  - (2) Selecting portions of the work to be performed by DBE companies in order to increase the likelihood that the DBE goals will be achieved. This includes, where appropriate, breaking out contract work items into economically feasible units to facilitate DBE participation, even when the prime contractor might otherwise prefer to perform these work items with its own forces.
  - (3) Providing interested DBE companies with adequate information about the plans, specifications, and requirements of the contract in a timely manner to assist them in responding to a solicitation.
  - (4) a. Negotiating in good faith with interested DBE companies. It is the bidder's responsibility to make a portion of the work available to DBE subcontractors and suppliers and to select those portions of the work or material needs consistent with the available DBE subcontractors and suppliers, so as to facilitate DBE participation. Evidence of such negotiation includes the names, addresses, and telephone numbers of DBE companies that were considered; a description of the information provided regarding the plans and specifications for the work selected for subcontracting; and evidence as to why additional agreements could not be reached for DBE companies to perform the work.  
  
b. A bidder using good business judgment would consider a number of factors in negotiating with subcontractors, including DBE subcontractors, and would take a firm's price and capabilities as well as contract goals into consideration. However, the fact that there may be some additional costs involved in finding and using DBE companies is not in itself sufficient reason for a bidder's failure to meet the contract DBE goal, as long as such costs are reasonable. Also, the ability or desire of a prime contractor to perform the work of a contract with its own organization does not relieve the bidder of the responsibility to make good faith efforts. Prime contractors are not, however, required to accept higher quotes from DBE companies if the price difference is excessive or unreasonable.
  - (5) Not rejecting DBE companies as being unqualified without sound reasons based on a thorough investigation of their capabilities. The contractor's standing within its

industry, membership in specific groups, organizations, or associations and political or social affiliations (for example union vs. non-union employee status) are not legitimate causes for the rejection or non-solicitation of bids in the contractor's efforts to meet the project goal.

- (6) Making efforts to assist interested DBE companies in obtaining bonding, lines of credit, or insurance as required by the recipient or contractor.
  - (7) Making efforts to assist interested DBE companies in obtaining necessary equipment, supplies, materials, or related assistance or services.
  - (8) Effectively using the services of available minority/women community organizations; minority/women contractors' groups; local, state, and Federal minority/women business assistance offices; and other organizations as allowed on a case-by-case basis to provide assistance in the recruitment and placement of DBE companies.
- (b) If the Department determines that the Contractor has made a good faith effort to secure the work commitment of DBE companies to meet the contract goal, the Department will award the contract provided that it is otherwise eligible for award. If the Department determines that a good faith effort has not been made, the Department will notify the bidder of that preliminary determination by contacting the responsible company official designated in the Utilization Plan. The preliminary determination shall include a statement of reasons why good faith efforts have not been found, and may include additional good faith efforts that the bidder could take. The notification will designate a five (5) working day period during which the bidder shall take additional efforts. The bidder is not limited by a statement of additional efforts, but may take other action beyond any stated additional efforts in order to obtain additional DBE commitments. The bidder shall submit an amended Utilization Plan if additional DBE commitments to meet the contract goal are secured. If additional DBE commitments sufficient to meet the contract goal are not secured, the bidder shall report the final good faith efforts made in the time allotted. All additional efforts taken by the bidder will be considered as part of the bidder's good faith efforts. If the bidder is not able to meet the goal after taking additional efforts, the Department will make a pre-final determination of the good faith efforts of the bidder and will notify the designated responsible company official of the reasons for an adverse determination.
- (c) The bidder may request administrative reconsideration of a pre-final determination adverse to the bidder within the five (5) working days after the notification date of the determination by delivering the request to the Department of Transportation, Bureau of Small Business Enterprises, Contract Compliance Section, 2300 South Dirksen Parkway, Room 319, Springfield, Illinois 62764 (Telefax: (217)785-1524). Deposit of the request in the United States mail on or before the fifth business day shall not be deemed delivery. The pre-final determination shall become final if a request is not made and delivered. A request may provide additional written documentation and/or argument concerning the issue of whether an adequate good faith effort was made to meet the contract goal. In addition, the request shall be considered a consent by the bidder to

extend the time for award. The request will be forwarded to the Department's Reconsideration Officer. The Reconsideration Officer will extend an opportunity to the bidder to meet in person in order to consider all issues of whether the bidder made a good faith effort to meet the goal. After the review by the Reconsideration Officer, the bidder will be sent a written decision within ten (10) working days after receipt of the request for reconsideration, explaining the basis for finding that the bidder did or did not meet the goal or make adequate good faith efforts to do so. A final decision by the Reconsideration Officer that a good faith effort was made shall approve the Utilization Plan submitted by the bidder and shall clear the contract for award. A final decision that a good faith effort was not made shall render the bid nonresponsive.

**CONTRACT COMPLIANCE.** Compliance with this Special Provision is an essential part of the contract. The Department is prohibited by federal regulations from crediting the participation of a DBE included in the Utilization Plan toward either the contract goal or the Department's overall goal until the amount to be applied toward the goals has been paid to the DBE. The following administrative procedures and remedies govern the compliance by the Contractor with the contractual obligations established by the Utilization Plan. After approval of the Plan and award of the contract, the Utilization Plan and individual DBE Participation Statements become part of the contract. If the contractor did not succeed in obtaining enough DBE participation to achieve the advertised contract goal, and the Utilization Plan was approved and contract awarded based upon a determination of good faith, the total dollar value of DBE work calculated in the approved Utilization Plan as a percentage of the awarded contract value shall become the amended contract goal.

- (a) No amendment to the Utilization Plan may be made without prior written approval from the Department's Bureau of Small Business Enterprises. All requests for amendment to the Utilization Plan shall be submitted to the Department of Transportation, Bureau of Small Business Enterprises, Contract Compliance Section, 2300 South Dirksen Parkway, Room 319, Springfield, Illinois 62764. Telephone number (217) 785-4611. Telefax number (217) 785-1524.
- (b) All work indicated for performance by an approved DBE shall be performed, managed and supervised by the DBE executing the Participation Statement. The Contractor shall not terminate for convenience a DBE listed in the Utilization Plan and then perform the work of the terminated DBE with its own forces, those of an affiliate or those of another subcontractor, whether DBE or not, without first obtaining the written consent of the Bureau of Small Business Enterprises to amend the Utilization Plan. If a DBE listed in the Utilization Plan is terminated for reasons other than convenience, or fails to complete its work on the contract for any reason, the Contractor shall make good faith efforts to find another DBE to substitute for the terminated DBE. The good faith efforts shall be directed at finding another DBE to perform at least the same amount of work under the contract as the DBE that was terminated, but only to the extent needed to meet the contract goal or the amended contract goal. The Contractor shall notify the Bureau of Small Business Enterprises of any termination for reasons other than convenience, and shall obtain approval for inclusion of the substitute DBE in the Utilization Plan. If good faith efforts following a termination of a DBE for cause are not successful, the Contractor

shall contact the Bureau and provide a full accounting of the efforts undertaken to obtain substitute DBE participation. The Bureau will evaluate the good faith efforts in light of all circumstances surrounding the performance status of the contract, and determine whether the contract goal should be amended.

- (c) The Contractor shall maintain a record of payments for work performed to the DBE participants. The records shall be made available to the Department for inspection upon request. After the performance of the final item of work or delivery of material by a DBE and final payment therefor to the DBE by the Contractor, but not later than thirty (30) calendar days after payment has been made by the Department to the Contractor for such work or material, the Contractor shall submit a DBE Payment Report on Department form SBE 2115 to the District Engineer. If full and final payment has not been made to the DBE, the Report shall indicate whether a disagreement as to the payment required exists between the Contractor and the DBE or if the Contractor believes that the work has not been satisfactorily completed. If the Contractor does not have the full amount of work indicated in the Utilization Plan performed by the DBE companies indicated in the Plan, the Department will deduct from contract payments to the Contractor the amount of the goal not achieved as liquidated and ascertained damages.
- (d) The Department reserves the right to withhold payment to the Contractor to enforce the provisions of this Special Provision. Final payment shall not be made on the contract until such time as the Contractor submits sufficient documentation demonstrating achievement of the goal in accordance with this Special Provision or after liquidated damages have been determined and collected.

80029

## EPOXY PAVEMENT MARKING (BDE)

Effective: January 1, 2001

Revised: August 1, 2003

Revise Article 1095.04(b) of the Standard Specifications to read:

"(b) The Epoxide Value (WPE) of Component A shall be tested according to ASTM D 1652 on a pigment free basis. The WPE shall not vary more than plus or minus 50 units of the qualification samples."

Revise Article 1095.04(c) of the Standard Specifications to read:

"(c) The Total Amine Value of Component B shall be tested according to ASTM D 2074. The Total Amine Value shall not vary more than plus or minus 50 units of the qualification samples."

Revise Article 1095.04(g) of the Standard Specifications to read:

"(g) The epoxy pavement marking material, when mixed in the proper mix ratio and applied at 0.35 mm to 0.41 mm (14 to 16 mils) wet film thickness and with the proper saturation of glass spheres, shall exhibit a dry no pick-up time of twenty minutes or less when tested according to ASTM D 711."

Revise Article 1095.04(m) of the Standard Specifications to read:

"(m) The glass beads meet the requirements of Article 1095.07 and the following:

- (1) The first drop glass beads shall be tested by the standard visual method of large glass spheres adopted by the Department. The beads shall have a silane coating and meet the following sieve requirements.

Sieve Size	U.S. Standard Sieve Number	% Passing (by weight)
1.70 mm	12	95-100
1.40 mm	14	75-95
1.18 mm	16	10-47
1.00 mm	18	0-7
850 µm	20	0-5

- (2) The second drop glass beads shall be Type B."

Revise the second sentence of the first paragraph of Article 1095.04(n) of the Standard Specifications to read:

"Subject the coated panel for 75 hours to accelerated weathering using the light and water exposure apparatus (fluorescent UV – condensation type) as specified in ASTM G 53 (equipped with UVB-313 lamps)."

80041



## **EXPANSION JOINTS (BDE)**

Effective: August 1, 2003

Add the following paragraph after the second paragraph of Article 420.10(e) of the Standard Specifications:

“After the dowel bars are oiled, plastic expansion caps shall be secured to the bars maintaining a minimum expansion gap of 50 mm (2 in.) between the end of the bar and the end of the cap. The caps shall fit snugly on the bar and the closed end shall be watertight. For expansion joints formed using dowel bar basket assemblies, the caps shall be installed on the alternating free ends of the bars. For expansion joints formed using a construction header, the caps shall be installed on the exposed end of each bar once the header has been removed and the joint filler material has been installed.”

80103

**FLAGGER VESTS (BDE)**

Effective: April 1, 2003

Revised: April 1, 2005

Revise the first sentence of Article 701.04(c)(1) of the Standard Specifications to read:

"The flagger shall be stationed to the satisfaction of the Engineer and be equipped with a fluorescent orange, fluorescent yellow/green or a combination of fluorescent orange and fluorescent yellow/green vest meeting the requirements of the American National Standards Institute specification ANSI/ISEA 107-1999 for Conspicuity Class 2 garments and approved flagger traffic control signs conforming to Standard 702001 and Article 702.05(e)."

Revise Article 701.04(c)(6) of the Standard Specifications to read:

"(6) Nighttime Flagging. The flagger station shall be lit by additional overhead lighting other than streetlights. The flagger shall be equipped with a fluorescent orange, fluorescent yellow/green, or a combination of fluorescent orange and fluorescent yellow/green garment meeting the requirements of the American National Standards Institute specification ANSI/ISEA 107-1999 for Conspicuity Class 3 garments."

80101

**FREEZE-THAW RATING (BDE)**

Effective: November 1, 2002

Revise the first sentence of Article 1004.02(f) of the Standard Specifications to read:

“When coarse aggregate is used to produce portland cement concrete for base course, base course widening, pavement, driveway pavement, sidewalk, shoulders, curb, gutter, combination curb and gutter, median, paved ditch or their repair using concrete, the gradation permitted will be determined from the results of the Department’s Freeze-Thaw Test.”

80079

**HAND VIBRATOR (BDE)**

Effective: November 1, 2003

Add the following paragraph to Article 1103.17(a) of the Standard Specifications:

"The vibrator shall have a non-metallic head for areas containing epoxy coated reinforcement. The head shall be coated by the manufacturer. The hardness of the non-metallic head shall be less than the epoxy coated reinforcement, resulting in no damage to the epoxy coating. Slip-on covers will not be allowed."

80054

**INLET FILTERS (BDE)**

Effective: August 1, 2003

Add the following to Article 280.02 of the Standard Specifications:

“(k) Inlet Filters..... 1081.15(h)”

Add the following paragraph after the first paragraph of Article 280.04(c) of the Standard Specifications:

“When specified, drainage structures shall be protected with inlet filters. Inlet filters shall be installed either directly on the drainage structure or under the grate of the drainage structure resting on the lip of the frame. The fabric bag shall hang down into the drainage structure. Prior to ordering materials, the Contractor shall determine the size and shape of the various drainage structures being protected.”

Revise Article 280.07(d) of the Standard Specifications to read:

“(d) Inlet and Pipe Protection. This work will be paid for at the contract unit price per each for INLET AND PIPE PROTECTION.

Protection of drainage structures with inlet filters will be paid for at the contract unit price per each for INLET FILTERS.”

Add the following to Article 1081.15 of the Standard Specifications:

“(h) Inlet Filters. An inlet filter shall consist of a steel frame with a two piece geotextile fabric bag attached with a stainless steel band and locking cap that is suspended from the frame. A clean, used bag and a used steel frame in good condition meeting the approval of the Engineer may be substituted for new materials. Materials for the inlet filter assembly shall conform to the following requirements:

(1) Frame Construction. Steel shall conform to Article 1006.04.

Frames designed to fit under a grate shall include an overflow feature that is welded to the frame's ring. The overflow feature shall be designed to allow full flow of water into the structure when the filter bag is full. The dimensions of the frame shall allow the drainage structure grate to fit into the inlet filter assembly frame opening. The assembly frame shall rest on the inside lip of the drainage structure frame for the full variety of existing and proposed drainage structure frames that are present on this contract. The inlet filter assembly frame shall not cause the drainage structure grate to extend higher than 6 mm (1/4 in.) above the drainage structure frame.

(2) Grate Lock. When the inlet is located in a traffic lane, a grate lock shall be used to secure the grate to the frame. The grate lock shall conform to the manufacturer's requirements for materials and installation.

(3) Geotextile Fabric Bag. The sediment bag shall be constructed of an inner filter bag and an outer reinforcement bag.

a. Inner Filter Bag. The inner filter bag shall be constructed of a polypropylene geotextile fabric with a minimum silt and debris capacity of 0.06 cu m (2.0 cu ft). The bag shall conform to the following requirements:

Inner Filter Bag		
Material Property	Test Method	Minimum Avg. Roll Value
Grab Tensile Strength	ASTM D 4632	45 kg (100 lb)
Grab Tensile Elongation	ASTM D 4632	50%
Puncture Strength	ASTM D 4833	29 kg (65 lb)
Trapezoidal Tear	ASTM D 4533	20 kg (45 lb)
UV Resistance	ASTM D 4355	70% at 500 hours
Actual Open Size	ASTM D 1420	212 µm (No. 70 sieve US)
Permittivity	ASTM D 4491	2.0/sec
Water Flow Rate	ASTM D 4491	5900 Lpm/sq m (145 gpm/sq ft)

b. Outer Reinforcement Bag. The outer reinforcement bag shall be constructed of polyester mesh material that conforms to the following requirements:

Outer Reinforcement Bag		
Material Property	Test Method	Value
Content	ASTM D 629	Polyester
Weight	ASTM D 3776	155 g/sq m (4.55 oz/sq yd) ±15%
Whales (holes)	ASTM D 3887	7.5 ± 2 holes/25 mm (1 in.)
Chorses (holes)	ASTM D 3887	15.5 ± 2holes/25 mm (1 in.)
Instronball Burst	ASTM D 3887	830 kPa (120 psi) min.
Thickness	ASTM D 1777	1.0 ± 0.1 mm (0.040 ± 0.005 in.)

(4) Certification. The manufacturer shall furnish a certification with each shipment of inlet filters, stating the amount of product furnished, and that the material complies with these requirements."

**LIGHT EMITTING DIODE (LED) SIGNAL HEAD (BDE)**

Effective: April 1, 2002  
Revised: August 1, 2003

Add the following paragraph to the end of Article 802.03 of the Standard Specifications:

"The warranty for light emitting diode (LED) modules, including the maintained minimum luminous intensities, shall cover a minimum of 60 months from the date of delivery."

Revise Article 880.01 of the Standard Specifications to read:

**"880.01 Description.** This work shall consist of furnishing and installing a conventional signal head, optically programmed signal head or light emitting diode (LED) signal head."

Revise Article 880.02(a) of the Standard Specifications to read:

"(a) Signal Heads.....1078.01"

Revise the first sentence of the first paragraph of Article 880.03 of the Standard Specifications to read:

"The signal head shall be installed on a post, bracket, span wire or mast arm as shown on the plans."

Revise the first paragraph of Article 880.04 of the Standard Specifications to read:

**"880.04 Basis of Payment.** This work will be paid for at the contract unit price each for SIGNAL HEAD, OPTICALLY PROGRAMMED SIGNAL HEAD, or SIGNAL HEAD, LED of the type specified and of the material type when specified."

Revise Article 1078.01 of the Standard Specifications to read:

**"1078.01 Signal Head, Optically Programmed Signal Head and Light Emitting Diode (LED) Signal Head."**

Add the following to Article 1078.01(c) of the Standard Specifications:

"(3) The LED signal section shall be according to the following:

- a. General Requirements. The LED signal head shall meet the requirements of the Institute of Transportation Engineers (ITE) interim LED purchase specification, "Vehicle Traffic Control Signal Heads, Part 2: LED Vehicle Traffic Signal Modules", or applicable successor ITE specifications, except as modified herein. The LEDs utilized in the modules shall not be Aluminum Gallium Arsenide (AlGaAs) material technology.

- b. Physical and Mechanical Requirements. The power supply for the LED module shall be integrated with the unit.
- c. Photometric Requirements. The candlepower values for yellow 300 mm (12 in.) circular modules shall be equal to the corresponding values for green 300 mm (12 in.) circular modules as listed in Table 1 of Section 4 of the aforementioned ITE specification based on normal use in traffic signal operation over the operating temperature range.

The illuminated portion of the arrow module shall be uniformly and completely dispersed with the LEDs.

- d. Electrical Requirements. When applicable to the particular module type, the LED signal module shall be EPA Energy Star qualified. For yellow 300 mm (12 in.) circular and arrow modules, the wattage requirements shall be as follows:

Module Type	Maximum Watts (W) at 74 °C (165 °F)	Nominal Watts (W) at 25 °C (77 °F)
300 mm (12 in.) Yellow Circular	25	22
300 mm (12 in.) Yellow Arrow	12	10

The individual LEDs shall be wired such that a catastrophic loss or the failure of one LED will result in the loss of not more than 5 percent of the signal module light output.

- e. Warranty. The LED modules shall be warrantied according to Article 802.03. The maintained minimum intensities for 300 mm (12 in.) arrow modules throughout the warranty period under the operating temperature and voltage range, and at the end of the warranty period shall not be less than the following values:

Module Type	Maintained Minimum Intensities (cd/sq m)
Red Arrow	5,000
Yellow Arrow	11,000
Green Arrow	11,000"

80067



**LIME GRADATION REQUIREMENTS (BDE)**

Effective: November 1, 2002

Revise Articles 1012.03(e) and 1012.04(e) of the Standard Specifications to modify the maximum percent retained on the 150  $\mu$ m (No. 100) sieve from "25" to "30".

80081

## **PARTIAL PAYMENTS (BDE)**

Effective: September 1, 2003

Revise Article 109.07 of the Standard Specifications to read:

**"109.07 Partial Payments.** Partial payments will be made as follows:

- (a) **Progress Payments.** At least once each month, the Engineer will make a written estimate of the amount of work performed in accordance with the contract, and the value thereof at the contract unit prices. The amount of the estimate approved as due for payment will be vouchered by the Department and presented to the State Comptroller for payment. No amount less than \$1000.00 will be approved for payment other than the final payment.

The failure to perform any requirement, obligation, or term of the contract by the Contractor shall be reason for withholding any progress payments until the Department determines that compliance has been achieved. Furthermore, progress payments may be reduced by liens filed pursuant to Section 23(c) of the Mechanics Lien Act, 770 ILCS 60/23(c).

- (b) **Material Allowances.** At the discretion of the Department, payment may be made for materials, prior to their use in the work, when satisfactory evidence is presented by the Contractor. Satisfactory evidence includes justification for the allowance (to expedite the work, meet project schedules, regional or national material shortages, etc.), documentation of material and transportation costs, and evidence that such material is properly stored on the project or at a secure location acceptable and accessible to the Department.

Material allowances will be considered only for nonperishable materials when the cost, including transportation, exceeds \$10,000 and such materials are not expected to be utilized within 60 days of the request for the allowance. For contracts valued under \$500,000, the minimum \$10,000 requirement may be met by combining the principal (material) product of no more than two contract items. An exception to this two item limitation may be considered for any contract regardless of value for items in which material (products) are similar except for type and/or size.

Material allowances shall not exceed the value of the contract items in which used and shall not include the cost of installation or related markups. Amounts paid by the Department for material allowances will be deducted from estimates due the Contractor as the material is used. Two-sided copies of the Contractor's cancelled checks for materials and transportation must be furnished to the Department within 60 days of payment of the allowances or the amounts will be reclaimed by the Department."

## PAVEMENT THICKNESS DETERMINATION FOR PAYMENT (BDE)

Effective: April 1, 1999  
Revised: January 1, 2004

Description. This work shall consist of determining pavement thickness for payment for full depth bituminous concrete and all pcc pavements. Pavement pay items that individually contain at least 840 sq m (1000 sq yd) of contiguous pavement will be subject to this Special Provision with the following exclusions: temporary pavements; variable width pavement; radius returns and side streets less than 125 m (400 ft) in length; and turn lanes of constant width less than 125 m (400 ft) in length. The areas of pavement excluded from the pay adjustment as described in this Special Provision will be cored according to Article 407.10 of the Standard Specifications. Temporary pavements are defined as pavements constructed and removed under this contract.

Materials. Rapid set materials shall be obtained from the Department's approved list of Packaged, Dry, Rapid Hardening Cementitious Materials For Concrete Repairs. Coarse aggregate may be added to the mortar if allowed by the manufacturer's instructions on the package. Mixing shall be according to the manufacture's recommendations.

Equipment. Cores shall be taken utilizing an approved coring machine. The cores shall have a diameter of 50 mm (2 in.). The cores shall be measured utilizing an approved measuring device.

### CONSTRUCTION REQUIREMENTS

Tolerance in Thickness. Determination of the pavement thickness shall be performed after the pavement surface tests and all corrective grinding are complete according to Article 407.09 of the Standard Specifications. Adjustments made in the contract unit price for pavement thickness will be in addition to and independent of those made for the Profile Index.

The pavement will be divided into approximately equal lots of not more than 1500 m (5000 ft) in length. When the length of a continuous strip of pavement is less than 1500 m (5000 ft), these short lengths of pavement, ramps, turn lanes, and other short sections of continuous pavement shall be grouped together to form lots of approximately 1500 m (5000 ft) in length. Short segments between structures will be measured continuously with the structure segments omitted. Each lot will be subdivided into ten equal sublots. The width of a subplot and lot will be the width from the pavement edge to the adjacent lane line, from one lane line to the next, or between pavement edges for single-lane pavements.

Fifty millimeter (Two inch) cores shall be taken from the pavement by the Contractor at random locations selected by the Engineer. When computing the thickness of a lot, one core will be taken per subplot. Core locations will be specified by the Engineer prior to beginning the coring operations.

The Contractor and the Engineer shall witness the coring operations, the measurement, and recording of the cores. Core measurements will be determined immediately upon removal from

the core bit and prior to moving to the next core location. Upon concurrence of the length, the core samples may be discarded.

Patching Holes. Upon completion of coring, all core holes shall be filled with a rapid set mortar or concrete. Only enough water to permit placement and consolidation by rodding shall be used, and the material shall be struck-off flush with the adjacent pavement.

For a rapid set mortar mixture, one part packaged rapid set cement shall be combined with two parts fine aggregate, by volume; or a packaged rapid set mortar shall be used. For a rapid set concrete mixture, a packaged rapid set mortar shall be combined with coarse aggregate according to the manufacturer's instructions or a packaged rapid set concrete shall be used. Mixing of a rapid set mortar or concrete shall be according to the manufacturer's instructions.

Deficient Sublot. When the thickness of the core in a sublot is deficient by more than ten percent of plan thickness, the Contractor will have the option of taking three additional cores selected at random by the Engineer within the same sublot at the Contractor's expense. The thickness of the additional three cores will be averaged with the original core thickness. When the average thickness shows the sublot to be deficient by ten percent or less, no additional action is necessary. If the Contractor chooses not to take additional cores, the pavement in the sublot shall be removed and replaced at the Contractor's expense. When additional cores are taken and the average thickness of the additional cores show the sublot to be deficient by more than ten percent, the pavement in that sublot shall be removed and replaced at the Contractor's expense. When requested in writing by the Contractor, the Engineer, at his/her option, may permit in writing such thin pavement to remain in place. For Bituminous Concrete Pavement (Full Depth) allowed to remain in place, additional lift(s) may be placed, at the Contractor's expense, to bring the deficient pavement to plan thickness when the Engineer determines grade control conditions will permit such lift(s). The material thickness(es), areas to be overlaid, and method of placement used for additional lift(s) will be approved by the Engineer. When the thin pavement is removed and replaced or additional lifts are placed, the replacement pavement will be retested for thickness at the Contractor's expense. When the thin pavement is left in place and no additional lift(s) are placed, no payment will be made for the deficient pavement sublot. The thickness of the original core taken in the sublot will be used in determining the payment for the entire lot and no adjustment to the pay factor will be made for any corrective action taken.

Deficient Lot. After analyzing the cores, the Percent Within Limits will be calculated. A lot of pavement represented by the Percent Within Limits (PWL) of 60 percent or less, shall be removed and replaced at the Contractor's expense. When requested in writing by the Contractor, the Engineer, at his/her option, may permit in writing such pavement to remain in place. For Bituminous Concrete Pavement (Full Depth), allowed to remain in place, additional lift(s) may be placed, at the Contractor's expense, to bring the deficient pavement to plan thickness when the Engineer determines grade control conditions will permit such lift(s). The material, thickness(es), areas to be overlaid and method of placement used for the additional lift(s) will be approved by the Engineer. After either corrective action, the Contractor shall core the lot according to the "Coring Procedures" at no additional cost to the Department. The PWL will then be recalculated for the lot, however, the pay factor for the lot will be a maximum of 100 percent. When requested in writing by the Contractor, the Engineer, at his/her option, may

permit in writing, the lot to remain in place. When the lot is left in place and no additional lifts are placed the pay factor for the lot will be based on the calculated PWL.

Right of Discovery. When the Engineer has reason to believe the random core selection process will not accurately represent the true conditions of the work, he/she may order cores in addition to those specified. The additional cores shall be taken at specific locations determined by the Engineer. The Engineer will provide notice to the Contractor containing an explanation of the reasons for his/her action. These additional cores and locations will be determined prior to commencement of coring operations. When the additional cores show the pavement to be deficient by more than ten percent, additional cores shall be taken at locations determined by the Engineer to determine the limits of the deficient pavement area. The deficient pavement area will be defined as the area between two acceptable cores. An acceptable core is a core with a thickness of 90 percent or more of plan thickness. The defined pavement area shall be removed and replaced at the Contractor's expense. When requested by the Contractor, the Engineer, at his/her option, may permit in writing such thin pavement to remain in place. On Bituminous Concrete Pavement (Full Depth) allowed to remain in place, additional lift(s) may be placed to bring the deficient pavement to plan thickness when the Engineer determines that grade control conditions will permit such lift(s). The material, thickness(es), areas to be overlaid and method of placement for the additional lift(s) will be approved by the Engineer. When the thin pavement is removed and replaced or additional lifts are placed, the replacement pavement will be retested for thickness at the Contractor's expense. When the thin pavement is left in place and no additional lift(s) are placed, no payment will be made for the deficient pavement. When the additional cores show the pavement to be deficient by ten percent or less the additional cores will be paid for according to Article 109.04. When the additional cores show the pavement to be deficient by more than ten percent the additional cores taken in the deficient area shall be at the Contractor's expense.

Profile Index Adjustment. After any section of pavement is removed and replaced or any additional lifts are added, the corrected areas shall be tested for pavement smoothness and any necessary Profile Index adjustments and/or corrections will be made based on these final profile readings. Such surface testing shall be performed at the Contractor's expense.

Core Analysis. Cores will be analyzed according to the following:

(a) Definition:

- $x_i$  = Individual values (core lengths) under consideration
- $n$  = Number of individual values under consideration  
(10 per lot)
- $\bar{x}$  = Average of the values under consideration
- LSL = Lower Specification Limit (LSL = 0.98 plan thickness for pavement)
- $Q_L$  = Lower Quality Index
- S = Sample Standard Deviation
- PWL = Percent Within Limits

Determine  $\bar{x}$  for the lot to the nearest two decimal places.

Compute the sample standard deviation to the nearest three decimal places using:

$$S = \sqrt{\frac{\sum (x_i - \bar{x})^2}{n-1}} \quad \text{where} \quad \sum (x_i - \bar{x})^2 = (x_1 - \bar{x})^2 + (x_2 - \bar{x})^2 + \dots + (x_{10} - \bar{x})^2$$

Determine the Lower Quality Index to the nearest two decimal places using:

$$Q_L = \frac{(\bar{x} - LSL)}{S}$$

Determine the percentage that will fall above the Lower Specification Limit (LSL) by going to the attached Table and utilizing calculated  $Q_L$ . Read the appropriate PWL value from the Table. For  $Q_L$  values less than zero the value shown in the table must be subtracted from 100 to obtain PWL.

Pay Adjustment. The following pay adjustment equation will be used to determine (to the nearest two decimal places) the pay factor for each lot.

$$\text{Pay Factor (PF) in percent} = 55 + 0.5 (\text{PWL})$$

If  $\bar{x}$  for a lot is less than the plan thickness, the maximum pay factor for that lot will be 100 percent.

Total Payment. The payment will be based on the appropriate pay items in Sections 407, 420, and 421. The final payment will be adjusted according to the following equation:

$$\text{Total Payment} = \text{TPF}[\text{CUP} (\text{TOTPAVT} - \text{DEFPAVT})]$$

TPF = Total Pay Factor

CUP = Contract Unit Price

TOTPAVT = Area of Pavement Subject to Coring

DEFPAVT = Area of Deficient Pavement

The TPF for the entire pavement will be the average of the PF for all the lots, however, not more than 102 percent of plan quantity will be paid.

Deficient pavement is defined as an area of pavement represented by a subplot deficient by more than 10 percent which is left in place with no additional thickness added.

All work involved in determining the total payment will be included in the contract unit prices of the pay items involved.

53600

58

Percent Within Limits

Quality Index (Q)*	Percent in Limits (PWL)	Quality Index (Q)*	Percent in Limits (PWL)	Quality Index (Q)*	Percent in Limits (PWL)	Quality Index (Q)*	Percent in Limits (PWL)	Quality Index (Q)*	Percent in Limits (PWL)	Quality Index (Q)*	Percent in Limits (PWL)	Quality Index (Q)*	Percent in Limits (PWL)	Quality Index (Q)*	Percent in Limits (PWL)	Quality Index (Q)*	Percent in Limits (PWL)	Quality Index (Q)*	Percent in Limits (PWL)		
0.00	50.00	.040	65.07	0.80	78.43	1.20	88.76	1.60	95.46	2.00	98.83	2.40	99.89	2.80	99.99	3.20	99.99	3.60	99.99	4.00	99.99
0.01	50.38	0.41	65.43	0.81	78.72	1.21	89.17	1.61	95.58	2.01	98.88	2.41	99.90	2.81	99.99	3.21	99.99	3.61	99.99	4.01	99.99
0.02	50.77	0.42	65.79	0.82	79.02	1.22	89.52	1.62	95.70	2.02	98.92	2.42	99.91	2.82	99.99	3.22	99.99	3.62	99.99	4.02	99.99
0.03	51.15	0.43	66.15	0.83	79.31	1.23	89.88	1.63	95.81	2.03	98.97	2.43	99.91	2.83	99.99	3.23	99.99	3.63	99.99	4.03	99.99
0.04	51.54	0.44	66.51	0.84	79.61	1.24	89.58	1.64	95.93	2.04	99.01	2.44	99.92	2.84	99.99	3.24	99.99	3.64	99.99	4.04	99.99
0.05	51.92	0.45	66.87	0.85	79.90	1.25	89.79	1.65	96.05	2.05	99.06	2.45	99.93	2.85	99.99	3.25	99.99	3.65	99.99	4.05	99.99
0.06	52.30	0.46	67.22	0.86	80.19	1.26	89.99	1.66	96.16	2.06	99.10	2.46	99.94	2.86	99.99	3.26	99.99	3.66	99.99	4.06	99.99
0.07	52.69	0.47	67.57	0.87	80.47	1.27	90.19	1.67	96.27	2.07	99.14	2.47	99.94	2.87	99.99	3.27	99.99	3.67	99.99	4.07	99.99
0.08	53.07	0.48	67.93	0.88	80.76	1.28	90.38	1.68	96.37	2.08	99.18	2.48	99.95	2.88	99.99	3.28	99.99	3.68	99.99	4.08	99.99
0.09	53.46	0.49	68.28	0.89	81.04	1.29	90.58	1.69	96.48	2.09	99.22	2.49	99.95	2.89	99.99	3.29	99.99	3.69	99.99	4.09	99.99
0.10	53.84	0.50	68.63	0.90	81.33	1.30	90.78	1.70	96.59	2.10	99.26	2.50	99.96	2.90	99.99	3.30	99.99	3.70	99.99	4.10	99.99
0.11	54.22	0.51	68.98	0.91	81.61	1.31	90.96	1.71	96.69	2.11	99.29	2.51	99.96	2.91	99.99	3.31	99.99	3.71	99.99	4.11	99.99
0.12	54.60	0.52	69.32	0.92	81.88	1.32	91.15	1.72	96.78	2.12	99.32	2.52	99.97	2.92	99.99	3.32	99.99	3.72	99.99	4.12	99.99
0.13	54.99	0.53	69.67	0.93	82.16	1.33	91.33	1.73	96.88	2.13	99.36	2.53	99.97	2.93	99.99	3.33	99.99	3.73	99.99	4.13	99.99
0.14	55.37	0.54	70.01	0.94	82.43	1.34	91.52	1.74	96.97	2.14	99.39	2.54	99.98	2.94	99.99	3.34	99.99	3.74	99.99	4.14	99.99
0.15	55.75	0.55	70.36	0.95	82.71	1.35	91.70	1.75	97.07	2.15	99.42	2.55	99.98	2.95	99.99	3.35	99.99	3.75	99.99	4.15	99.99
0.16	56.13	0.56	70.70	0.96	82.97	1.36	91.87	1.76	97.16	2.16	99.45	2.56	99.98	2.96	99.99	3.36	99.99	3.76	99.99	4.16	99.99
0.17	56.51	0.57	71.04	0.97	83.24	1.37	92.04	1.77	97.25	2.17	99.48	2.57	99.98	2.97	99.99	3.37	99.99	3.77	99.99	4.17	99.99
0.18	56.89	0.58	71.38	0.98	83.50	1.38	92.22	1.78	97.33	2.18	99.50	2.58	99.99	2.98	99.99	3.38	99.99	3.78	99.99	4.18	99.99
0.19	57.27	0.59	71.72	0.99	83.77	1.39	92.39	1.79	97.42	2.19	99.53	2.59	99.99	2.99	99.99	3.39	99.99	3.79	99.99	4.19	99.99
0.20	57.65	0.60	72.06	1.00	84.03	1.40	92.56	1.80	97.51	2.20	99.56	2.60	99.99	3.00	99.99	3.40	99.99	3.80	99.99	4.20	99.99
0.21	58.03	0.61	72.39	1.01	84.28	1.41	92.72	1.81	97.59	2.21	99.58	2.61	99.99	3.01	99.99	3.41	99.99	3.81	99.99	4.21	99.99
0.22	58.40	0.62	72.72	1.02	84.53	1.42	92.88	1.82	97.67	2.22	99.61	2.62	99.99	3.02	99.99	3.42	99.99	3.82	99.99	4.22	99.99
0.23	58.78	0.63	73.06	1.03	84.79	1.43	93.05	1.83	97.75	2.23	99.63	2.63	100.00	3.03	99.99	3.43	99.99	3.83	99.99	4.23	99.99
0.24	59.15	0.64	73.39	1.04	85.04	1.44	93.21	1.84	97.83	2.24	99.66	2.64	100.00	3.04	99.99	3.44	99.99	3.84	99.99	4.24	99.99
0.25	59.53	0.65	73.72	1.05	85.29	1.45	93.37	1.85	97.91	2.25	99.68	2.65	100.00	3.05	99.99	3.45	99.99	3.85	99.99	4.25	99.99
0.26	59.90	0.66	74.04	1.06	85.53	1.46	93.52	1.86	97.98	2.26	99.70	2.66	100.00	3.06	99.99	3.46	99.99	3.86	99.99	4.26	99.99
0.27	60.28	0.67	74.36	1.07	85.77	1.47	93.67	1.87	98.05	2.27	99.72	2.67	100.00	3.07	99.99	3.47	99.99	3.87	99.99	4.27	99.99
0.28	60.65	0.68	74.69	1.08	86.02	1.48	93.83	1.88	98.11	2.28	99.73	2.68	100.00	3.08	99.99	3.48	99.99	3.88	99.99	4.28	99.99
0.29	61.03	0.69	75.01	1.09	86.26	1.49	93.98	1.89	98.18	2.29	99.75	2.69	100.00	3.09	99.99	3.49	99.99	3.89	99.99	4.29	99.99
0.30	61.40	0.70	75.33	1.10	86.50	1.50	94.13	1.90	98.25	2.30	99.77	2.70	100.00	3.10	99.99	3.50	99.99	3.90	99.99	4.30	99.99
0.31	61.77	0.71	75.64	1.11	86.73	1.51	94.27	1.91	98.31	2.31	99.78	2.71	100.00	3.11	99.99	3.51	99.99	3.91	99.99	4.31	99.99
0.32	62.14	0.72	75.96	1.12	86.96	1.52	94.41	1.92	98.37	2.32	99.80	2.72	100.00	3.12	99.99	3.52	99.99	3.92	99.99	4.32	99.99
0.33	62.51	0.73	76.27	1.13	87.20	1.53	94.54	1.93	98.44	2.33	99.81	2.73	100.00	3.13	99.99	3.53	99.99	3.93	99.99	4.33	99.99
0.34	62.88	0.74	76.59	1.14	87.43	1.54	94.68	1.94	98.50	2.34	99.83	2.74	100.00	3.14	99.99	3.54	99.99	3.94	99.99	4.34	99.99
0.35	63.25	0.75	76.90	1.15	87.66	1.55	94.82	1.95	98.56	2.35	99.84	2.75	100.00	3.15	99.99	3.55	99.99	3.95	99.99	4.35	99.99
0.36	63.61	0.76	77.21	1.16	87.88	1.56	94.95	1.96	98.61	2.36	99.85	2.76	100.00	3.16	99.99	3.56	99.99	3.96	99.99	4.36	99.99
0.37	63.98	0.77	77.51	1.17	88.10	1.57	95.08	1.97	98.67	2.37	99.86	2.77	100.00	3.17	99.99	3.57	99.99	3.97	99.99	4.37	99.99
0.38	64.34	0.78	77.82	1.18	88.32	1.58	95.20	1.98	98.72	2.38	99.87	2.78	100.00	3.18	99.99	3.58	99.99	3.98	99.99	4.38	99.99
0.39	64.71	0.79	78.12	1.19	88.54	1.59	95.33	1.99	98.78	2.39	99.88	2.79	100.00	3.19	99.99	3.59	99.99	3.99	99.99	4.39	99.99

\*For Q values less than zero, subtract the table value from 100 to obtain PWL

## **PAYMENTS TO SUBCONTRACTORS (BDE)**

Effective: June 1, 2000  
Revised: September 1, 2003

Federal regulations found at 49 CFR §26.29 mandate the Department to establish a contract clause to require Contractors to pay subcontractors for satisfactory performance of their subcontracts no later than 30 days from the receipt of each payment made to the Contractor.

State law addresses the timing of payments to be made to subcontractors. Section 7 of the Prompt Payment Act, 30 ILCS 540/7, generally requires that when a Contractor receives any payment from the Department, the Contractor is required to make corresponding, proportional payments to each subcontractor performing work within 15 calendar days after receipt of the state payment. Section 7 of the State Prompt Payment Act further provides that interest in the amount of 2% per month, in addition to the payment due, shall be paid to any subcontractor by the Contractor if the payment required by the Act is withheld or delayed without reasonable cause. The Act also provides that the time for payment required and the calculation of any interest due applies to transactions between subcontractors and lower-tier subcontractors throughout the contracting chain.

This Special Provision establishes the required federal contract clause, and adopts the 15 calendar day requirement of the Act for purposes of compliance with the federal regulation regarding payments to subcontractors. This contract is subject to the following payment obligations.

As progress payments are made to the Contractor in accordance with Article 109.07 of the Standard Specifications for Road and Bridge Construction, the Contractor shall make a corresponding partial payment within 15 calendar days to each subcontractor in proportion to the work satisfactorily completed by each subcontractor. The proportionate amount of partial payment due to each subcontractor shall be determined by the quantities measured or otherwise determined as eligible for payment by the Department and included in the progress payment to the Contractor. Subcontractors shall be paid in full within 15 calendar days after the subcontractor's work has been satisfactorily completed. The Contractor shall hold no retainage from the subcontractors.

This Special Provision does not create any rights in favor of any subcontractor against the State of Illinois or authorize any cause of action against the State of Illinois on account of any payment, nonpayment, delayed payment or interest claimed by application of the State Prompt Payment Act. The Department will neither determine the reasonableness of any cause for delay of payment nor enforce any claim to payment, including interest. Moreover, the Department will not approve any delay or postponement of the 15 day requirement. State law creates remedies available to any subcontractor or material supplier, regardless of tier, who has not been paid for work properly performed or material furnished. These remedies are a lien against public funds set forth in Section 23(c) of the Mechanics Lien Act, 770 ILCS 60/23(c), and a recovery on the Contractor's payment bond in accordance with the Public Construction Bond Act, 30 ILCS 550.

80022



## **PERSONAL PROTECTIVE EQUIPMENT (BDE)**

Effective: July 1, 2004

All personnel, excluding flaggers, working outside of a vehicle (car or truck) within 7.6 m (25 ft) of pavement open to traffic shall wear a fluorescent orange, fluorescent yellow/green or a combination of fluorescent orange and fluorescent yellow/green vest meeting the requirements of the American National Standards Institute specification ANSI/ISEA 107-1999 for Conspicuity Class 2 garments. Other types of garments may be substituted for the vest as long as the garments have manufacturers tags identifying them as meeting the ANSI Class 2 requirement.

80130

**PORTLAND CEMENT (BDE)**

Effective: January 1, 2005

Replace the first sentence of the second paragraph of Article 1001.01 of the Standard Specifications with the following:

“For portland cement according to ASTM C 150, the addition of up to 5.0 percent limestone by mass (weight) to the cement will not be permitted. Also, the total of all organic processing additions shall not exceed 1.0 percent by mass (weight) of the cement and the total of all inorganic processing additions shall not exceed 4.0 percent by mass (weight) of the cement.”

80139

**PORTLAND CEMENT CONCRETE (BDE)**

Effective: November 1, 2002

Add the following paragraph after the fourth paragraph of Article 1103.01(b) of the Standard Specifications:

"The truck mixer shall be approved before use according to the Bureau of Materials and Physical Research's Policy Memorandum, "Approval of Concrete Plants and Delivery Trucks"."

Add the following paragraph after the first paragraph of Article 1103.01(c) of the Standard Specifications:

"The truck agitator shall be approved before use according to the Bureau of Materials and Physical Research's Policy Memorandum, "Approval of Concrete Plants and Delivery Trucks"."

Add the following paragraph after the first paragraph of Article 1103.01(d) of the Standard Specifications:

"The nonagitator truck shall be approved before use according to the Bureau of Materials and Physical Research's Policy Memorandum, "Approval of Concrete Plants and Delivery Trucks"."

Revise the first sentence of the first paragraph of Article 1103.02 of the Standard Specifications to read:

"The plant shall be approved before production begins according to the Bureau of Materials and Physical Research's Policy Memorandum, "Approval of Concrete Plants and Delivery Trucks"."

80083

## PRECAST CONCRETE PRODUCTS (BDE)

Effective: July 1, 1999

Revised: November 1, 2004

Product Approval. Precast concrete products shall be produced according to the Department's current Policy Memorandum, "Quality Control/Quality Assurance Program for Precast Concrete Products". The Policy Memorandum applies to precast concrete products listed under the Products Key of the "Approved List of Certified Precast Concrete Producers".

Precast Concrete Box Culverts. Add the following sentence to the end of the fourth paragraph of Article 540.06:

"After installation, the interior and exterior joint gap between precast concrete box culvert sections shall not exceed 38 mm (1 1/2 in.)."

Portland Cement Replacement. For precast concrete products using Class PC concrete or other mixtures, portland cement replacement with fly ash or ground granulated blast-furnace (GGBF) slag shall be governed by the AASHTO or ASTM standard specification referenced in the Standard Specifications.

For all other precast concrete products using Class PC concrete or other mixtures, portland cement replacement with fly ash or GGBF slag shall be approved by the Engineer. Class F fly ash shall not exceed 15 percent by mass (weight) of the total portland cement and Class F fly ash. Class C fly ash shall not exceed 20 percent by mass (weight) of the total portland cement and Class C fly ash. GGBF slag shall not exceed 25 percent by mass (weight) of the total portland cement and GGBF slag.

Concrete mix designs, for precast concrete products, shall not consist of portland cement, fly ash and GGBF slag.

Ready-Mixed Concrete. Delete the last paragraph of Article 1020.11(a) of the Standard Specifications.

Shipping. When a precast concrete product has attained the specified strength, the earliest the product may be loaded, shipped, and used is on the fifth calendar day. The first calendar day shall be the date casting was completed.

Acceptance. Products which have been lot or piece inspected and approved by the Department prior to July 1, 1999; will be accepted for use on this contract.

419.doc

**PREFORMED RECYCLED RUBBER JOINT FILLER (BDE)**

Effective: November 1, 2002

Revise Article 503.02(c) of the Standard Specifications to read:

“(c) Prefomed Expansion Joint Filler.....1051”

Revise Article 637.02(d) of the Standard Specifications to read:

“(d) Prefomed Expansion Joint Filler.....1051”

Add the following Article to Section 1051 of the Standard Specifications:

“1051.10 Prefomed Recycled Rubber Joint Filler. Prefomed recycled rubber joint filler shall consist of ground tire rubber, free of steel and fabric, combined with ground scrap or waste polyethylene. It shall not have a strong hydrocarbon or rancid odor and shall meet the physical property requirements of ASTM D 1752. Water absorption by volume shall not exceed 5.0 percent.”

80084

## RAP FOR USE IN BITUMINOUS CONCRETE MIXTURES (BDE)

Effective: January 1, 2000

Revised: April 1, 2002

Revise Article 1004.07 to read:

**"1004.07 RAP Materials.** RAP is reclaimed asphalt pavement resulting from cold milling or crushing of an existing dense graded hot-mix asphalt pavement. RAP must originate from routes or airfields under federal, state or local agency jurisdiction. The Contractor shall supply documentation that the RAP meets these requirements.

- (a) Stockpiles. The Contractor shall construct individual, sealed RAP stockpiles meeting one of the following definitions. No additional RAP will be allowed on top of the pile after the pile has been sealed.
  - (1) Homogeneous. Homogeneous RAP stockpiles shall consist of RAP from Class I/ Superpave, or equivalent mixtures only and represent the same aggregate quality, but shall be at least C quality or better, the same type of crushed aggregate (either crushed natural aggregate, ACBF slag, or steel slag), similar gradation and similar AC content. If approved by the Engineer, combined single pass surface/binder millings may be considered "homogenous", with a quality rating dictated by the lowest coarse aggregate quality present in the mixture. Homogenous stockpiles shall meet the requirements of Article 1004.07(d). Homogeneous RAP stockpiles not meeting these requirements may be processed (crushing and screening) and retested.
  - (2) Conglomerate. Conglomerate RAP stockpiles shall consist of RAP from Class I/ Superpave, or equivalent mixtures only. The coarse aggregate in this RAP shall be crushed aggregate only and may represent more than one aggregate type and/or quality but shall be at least C quality or better. This RAP may have an inconsistent gradation and/or asphalt cement content prior to processing. All conglomerate RAP shall be processed prior to testing by crushing to where all RAP shall pass the 16 mm (5/8 in.) or smaller screen. Conglomerate RAP stockpiles shall not contain steel slag or other expansive material as determined by the Department. Conglomerate RAP stockpiles shall meet the requirements of Article 1004.07(d).
  - (3) Conglomerate "D" Quality (DQ). Conglomerate DQ RAP stockpiles shall consist of RAP containing coarse aggregate (crushed or round) that is at least D quality or better. This RAP may have an inconsistent gradation and/or asphalt content. Conglomerate DQ RAP stockpiles shall not contain steel slag or other expansive material as determined by the Department. Conglomerate DQ RAP shall meet the requirements of Article 1004.07(d).

Reclaimed Superpave Low ESAL IL-9.5L surface mixtures shall only be placed in conglomerate DQ RAP stockpiles due to the potential for rounded aggregate.

- (4) Other. RAP stockpiles that do not meet the requirements of the stockpile categories listed above shall be classified as "Other". "Other" RAP stockpiles shall not be used in any of the Department's bituminous mixtures.
- (b) Use. The allowable use of a RAP stockpile shall be set by the lowest quality of coarse aggregate in the RAP stockpile. Class I/Superpave surface mixtures are designated as containing Class B quality coarse aggregate only. Superpave Low ESAL IL-19.0L binder and IL-9.5L surface mixtures are designated as Class C quality coarse aggregate only. Class I/Superpave binder mixtures, bituminous base course mixtures, and bituminous base course widening mixtures are designated as containing Class C quality coarse aggregate only. Bituminous stabilized subbase and BAM shoulders are designated as containing Class D quality coarse aggregate only. Any mixture not listed above shall have the designated quality determined by the Department.

RAP containing steel slag or other expansive material, as determined by the Department, shall be homogeneous and will be approved for use in Class I/Superpave (including Low ESAL) surface mixtures only. RAP stockpiles for use in Class I/Superpave mixtures (including Low ESAL), base course, base course widening and Class B mixtures shall be either homogeneous or conglomerate RAP stockpiles except conglomerate RAP stockpiles shall not be used in Superpave surface mixture Ndesign 50 or greater. RAP for use in bituminous aggregate mixtures (BAM) shoulders and BAM stabilized subbase shall be from homogeneous, conglomerate, or conglomerate DQ stockpiles.

Additionally, RAP used in Class I/Superpave surface mixtures shall originate from milled or crushed mixtures only, in which the coarse aggregate is of Class B quality or better. RAP stockpiles for use in Class I/Superpave (including Low ESAL) binder mixes as well as base course, base course widening and Class B mixtures shall originate from milled or processed surface mixture, binder mixture, or a combination of both mixtures uniformly blended to the satisfaction of the Engineer, in which the coarse aggregate is of Class C quality or better.

- (c) Contaminants. RAP containing contaminants, such as earth, brick, sand, concrete, sheet asphalt, bituminous surface treatment (i.e. chip seal), pavement fabric, etc., will be unacceptable unless the contaminants are removed to the satisfaction of the Engineer. Sheet asphalt shall be stockpiled separately.
- (d) Testing. All RAP shall be sampled and tested either during or after stockpiling.

For testing during stockpiling, washed extraction samples shall be run at the minimum frequency of one sample per 450 metric tons (500 tons) for the first 1800 metric tons (2,000 tons) and one sample per 1800 metric tons (2,000 tons) thereafter. A minimum of five tests shall be required for stockpiles less than 3600 metric tons (4,000 tons).

For testing existing stockpiles, the Contractor shall submit a plan for approval to the District proposing a satisfactory method of sampling and testing the RAP pile either in-situ or by restockpiling. The sampling plan shall meet the minimum frequency required above and detail the procedure used to extract representative samples throughout the pile for testing.

Before extraction, each field sample shall be split to test sample size. One of the two test samples from the final split shall be labeled and stored for Department use. The Contractor shall extract the other test sample according to Department procedure. The Engineer reserves the right to test any sample (split or Department-taken) to verify Contractor test results.

All of the extraction results shall be compiled and averaged for asphalt content and gradation. Individual extraction test results, when compared to the averages, will be accepted if within the tolerances listed below.

Parameter	Homogeneous / Conglomerate	Conglomerate "D" Quality
25 mm (1 in.)		± 5%
12.5 mm (1/2 in.)	± 8%	± 15%
4.75 mm (No. 4)	± 6%	± 13%
2.36 mm (No. 8)	± 5%	
1.18 mm (No. 16)		± 15%
600 μm (No. 30)	± 5%	
75 μm (No. 200)	± 2.0%	± 4.0%
AC	± 0.4%	± 0.5%

If more than 20 percent of the individual sieves are out of the gradation tolerances, or if more than 20 percent of the asphalt content test results fall outside the appropriate tolerances, the RAP will not be allowed to be used in the Department's bituminous concrete mixtures unless the RAP representing the failing tests is removed from the stockpile to the satisfaction of the Engineer. All test data and acceptance ranges shall be sent to the District for evaluation.

With the approval of the Engineer, the ignition oven may be substituted for extractions according to the Illinois Test Procedure, "Calibration of the Ignition Oven for the Purpose of Characterizing Reclaimed Asphalt Pavement (RAP)".

- (e) Designs. At the Contractor's option, bituminous concrete mixtures may be constructed utilizing RAP material meeting the above detailed requirements. The amount of RAP included in the mixture shall not exceed the percentages specified in the plans.

RAP designs shall be submitted for volumetric verification. If additional RAP stockpiles are tested and found that no more than 20 percent of the results, as defined under "Testing" herein, are outside of the control tolerances set for the original RAP stockpile



and design, and meets all of the requirements herein, the additional RAP stockpiles may be used in the original mix design at the percent previously verified.

- (f) Production. The coarse aggregate in all RAP used shall be equal to or less than the nominal maximum size requirement for the bituminous mixture being produced.

To remove or reduce agglomerated material, a scalping screen, crushing unit or comparable sizing device approved by the Engineer shall be used in the RAP feed system to remove or reduce oversized material. If material passing the sizing device adversely affects the mix production or quality of the mix, the sizing device shall be set at a size specified by the Engineer.

If the RAP control tolerances or QC/QA test results require corrective action, the Contractor shall cease production of the mixture containing RAP and either switch to the virgin aggregate design or submit a new RAP design.

80011

## SELF-CONSOLIDATING CONCRETE FOR PRECAST PRODUCTS (BDE)

Effective: July 1, 2004

Definition. Self-consolidating concrete is a flowable mixture that does not require mechanical vibration for consolidation.

Usage. Self-consolidating concrete may be used for precast concrete products. The design and testing of a self-consolidating concrete mixture shall be according to Section 1020 of the Standard Specifications except as modified herein.

Materials. Materials shall conform to the following requirements:

- (a) Self-Consolidating Admixtures. The self-consolidating admixture system shall consist of either a high range water-reducing admixture only or a high range water-reducing admixture combined with a separate viscosity modifying admixture. The one or two component admixture system shall be capable of producing a flowable concrete that does not require mechanical vibration.

The high range water-reducing admixture shall comply with the requirements of AASHTO M 194, Type F.

The viscosity modifying admixture will be evaluated according to the test methods and mix design proportions referenced in AASHTO M 194, except the following physical requirements shall be met:

- (1) For initial and final set times, the allowable deviation of the test concrete from the reference concrete shall not be more than 1.0 hour earlier or 1.5 hours later.
  - (2) For compressive and flexural strengths, the test concrete shall be a minimum of 90 percent of the reference concrete at 3, 7 and 28 days.
  - (3) The length change of the test concrete shall be a maximum 135 percent of the reference concrete. However, if the length change of the reference concrete is less than 0.030 percent, the length change of the test concrete shall be a maximum 0.010 percentage units greater than the reference concrete.
  - (4) The relative durability factor of the test concrete shall be a minimum 80 percent.
- (b) Fine Aggregate. A fine aggregate used alone in the mix design shall not have an expansion greater than 0.30 percent per ASTM C 1260. For a blend of two or more fine aggregates, the resulting blend shall not have an expansion greater than 0.30 percent.

The aggregate blend expansion will be calculated as follows:

$$\text{Aggregate Blend Expansion} = (a/100 \times A) + (b/100 \times B) + (c/100 \times C) + \dots \text{etc.}$$

Where: a, b, c, ... = percent of aggregate blend  
A, B, C, ... = aggregate expansion according to ASTM C 1260

Mix Design Criteria. The slump requirements of Article 1020.04 of the Standard Specifications shall not apply. In addition, the allowable coarse aggregate gradations shall be CA 11, CA 13, CA 14, CA 16, or a blend of these gradations. The fine aggregate proportion shall be a maximum 50 percent by mass (weight) of the total aggregate used.

Trail Batch. A minimum 1 cu m (1 cu yd) trial batch shall be produced. The mixture will be evaluated for air content, slump flow, visual stability index, compressive strength, passing ability, and static/dynamic segregation resistance.

The trial batch shall be scheduled and performed in the presence of the Engineer. Testing shall be performed per the Department's test method or as approved by the Engineer.

For the trial batch, the air content shall be within the top half of the allowable specification range. The slump flow range shall be 510 mm (20 in.) minimum to 710 mm (28 in.) maximum. The visual stability index shall be a maximum of 1. Strength shall be determined at 28 days. At the Contractor's option, strength may be determined for additional days.

Passing ability and static/dynamic segregation resistance shall be determined by tests selected by the Contractor and approved by the Engineer. The visual stability index shall not be used as the sole criteria for evaluating static segregation resistance.

After an acceptable mixture has been batched and tested, the mixture shall also be evaluated for robustness. Robustness shall be evaluated by varying the dosage of the self-consolidating admixture system and water separately. Additional trial batches may be necessary to accomplish this.

When necessary, the trial batches shall be disposed of according to Article 202.03 of the Standard Specifications.

Quality Control. Once testing is completed and acceptable results have been attained, production test frequencies and allowable test ranges for slump flow, visual stability index, passing ability, and static/dynamic segregation resistance shall be proposed. The production test frequencies and allowable test ranges will be approved by the Engineer.

The slump flow range shall be  $\pm 50$  mm ( $\pm 2$  in.) of the target value, and within the overall range of 510 mm (20 in.) minimum to 710 mm (28 in.) maximum. The visual stability index shall be a maximum of 1. The approved test ranges for passing ability and static/dynamic segregation resistance will be based on recommended guidelines determined by the Engineer.

**SOIL MODIFICATION (BDE)**

Effective: November 1, 2004

Revised: April 1, 2005

Revise Section 302 of the Standard Specifications to read:

**"SECTION 302. SOIL MODIFICATION**

**302.01 Description.** This work shall consist of constructing a modified soil layer composed of soil, water, and a modifier.

**302.02 Materials.** Materials shall meet the requirements of the following Articles of Section 1000 Materials:

Item	Article/Section
(a) Type I Portland Cement .....	1001
(b) Type I (SM) Slag-Modified Portland Cement .....	1001
(c) Water.....	1002
(d) Hydrated Lime.....	1012.01
(e) By-Product, Hydrated Lime (Note 1)	
(f) By-Product, Non-Hydrated Lime (Note 2)	
(g) Lime Slurry (Note 3)	
(h) Class C Fly Ash (Note 4)	
(i) Soil (Note 5)	
(j) Bituminous Materials (Note 6).....	1009.07, 1009.08, 1009.09

Note 1. By-product, hydrated lime (hydrator tailings) shall conform to the following requirements:

Parameter	Value
Total calcium and magnesium oxides (nonvolatile basis)	90 % minimum
Available calcium hydroxide (rapid sugar test, ASTM C 25) plus total MgO content calculated to be equivalent Ca(OH) <sub>2</sub>	70 % minimum
As received loss on ignition (carbon dioxide plus moisture, combined and free)	5 % maximum
Free water (as-received basis)	4 % maximum
SO <sub>3</sub>	10 % maximum

The sieve analysis of the lime residue shall be as follows:

Sieve	Maximum Percent Retained
4.75 mm (No. 4)	0
600 µm (No. 30)	10

150 µm (No. 100)	60
------------------	----

Note 2. By-product, non-hydrated lime (lime kiln dust) shall conform to the following requirements:

Parameter	Value
Total calcium and magnesium oxides (nonvolatile basis)	60 % minimum
Available calcium hydroxide (rapid sugar test, ASTM C 25) plus total MgO content calculated to be equivalent Ca (OH) <sub>2</sub>	30 % minimum
As received loss on ignition (carbon dioxide plus moisture, combined and free)	40 % maximum
Free water (as received basis)	4 % maximum
SO <sub>3</sub>	10 % maximum

The sieve analysis of the lime residue shall be as follows:

Sieve	Maximum Percent Retained
4.75 mm (No. 4)	5
600 µm (No. 30)	10
150 µm (No. 100)	30

Note 3. The lime used in the slurry shall be either hydrated lime conforming to the requirements of ASTM C 207, Type N, or quicklime conforming to the requirements for calcium lime as stated in ASTM C 5. The quantity of lime (hydrated lime or quicklime) in the slurry shall be a minimum of 35 percent and a maximum of 45 percent by total mass (weight) of slurry.

Note 4. The fly ash shall meet the physical and chemical requirements of AASHTO M 295, Class C.

Note 5. When lime (slurry or dry) is used as the modifier, the soil shall have a minimum clay content of 15 percent, determined according to AASHTO T 88; and shall have a maximum organic matter content of 10 percent, determined according to AASHTO T 194.

Note 6. The bituminous materials used for curing shall be emulsified asphalt RS-1, RS-2, CRS-1, CRS-2, HFE 60, HFE 90, or HFE 150; rapid curing liquid asphalt RC-70 or RC-250; or medium curing liquid asphalt MC-70 or MC-250.

**302.03 Equipment.** Equipment shall meet the requirements of the following Articles of Section 1100 - Equipment:

Item	Article/Section
(a) Rotary Speed Mixer .....	1101.06

- (b) Disk Harrow (Note 1).....1101.02
- (c) Distributor (Note 2)
- (d) Lime Slurry Equipment (Note 3)

Note 1. A disk harrow may be used for soil modification with portland cement, slag-modified portland cement, or lime (slurry or dry) when permitted by the Engineer.

Note 2. The distributor shall be of a mechanical type and shall be approved by the Engineer.

Note 3. The equipment used for mixing, transporting, slaking, and placing lime slurry shall be approved by the Engineer.

**302.04 Proportioning.** Proportioning shall be as follows.

- (a) Samples. Samples of the soil modifier(s) and the project soil(s) shall be obtained and submitted to the Engineer at least 45 days prior to the construction of the modified soil. Sample sizes shall be a minimum of 12 kg (25 lb) for the modifier(s) and 90 kg (200 lb) for the project soil(s).
- (b) Mix Design. The actual proportions of modifier, soil, and water will be determined by the Engineer prior to construction using the submitted samples. The Engineer reserves the right to make such adjustments in proportions as are considered necessary during the progress of the work.

In no case shall proportions or type of modifier be changed during the progress of the work without permission by the Engineer.

**CONSTRUCTION REQUIREMENTS**

**302.05 General.** The modified soil shall be constructed when the temperature of the soil, measured 150 mm (6 in.) below the surface, is above 10 °C (50 °F); and the ambient air temperature in the shade is above 7 °C (45 °F).

The quantity of modified soil constructed shall be limited to that which can be covered by the succeeding pavement layer during the same construction season.

**302.06 Preparation of Subgrade.** The area to be processed shall be shaped to the proper grade and cross section. All vegetation and other objectionable material shall be removed from within the limits of modification. In cut or at grade sections, the subgrade shall be prepared according to Article 301.03, Steps 1 and 2. The subgrade shall be compacted adequately for the equipment to modify the soil.

**302.07 Application of Modifier.** The modifier shall be applied uniformly on the soil. The application of modifier shall be limited to that amount which can be incorporated into the soil within the same working day.

After application of dry modifiers, but before the addition of any water, the surface of the subgrade shall be lightly scarified or disked. When lime slurry is used, the surface of the subgrade shall be lightly scarified or disked prior to application of the slurry.

Dry modifiers shall not be applied when wind conditions are such that blowing modifier becomes objectionable to adjacent property owners or creates a hazard to traffic on adjacent highways, as determined by the Engineer.

Lime slurry shall be applied within 30 days of preparing and mixing the slurry, and shall be thoroughly agitated prior to application.

Modifier which has been damaged by hydration due to rain prior to or during the mixing operations, or has been displaced by the Contractor's equipment or other traffic after application shall be replaced.

**302.08 Mixing.** The modifier, soil, and water shall be thoroughly mixed. Mixing shall continue until a homogeneous layer of the required thickness has been obtained and a minimum of 75 percent of the mixture is smaller than 25 mm (1 in.). The moisture content of the modified soil shall be between optimum and three percent above optimum.

For soil modification with fly ash, more than one pass of the rotary speed mixer may be necessary to obtain a homogenous mixture. If more than one pass of the rotary speed mixer is required, the application of the fly ash shall be modified such that 25 percent of the specified fly ash quantity is applied and mixed with a down-cut motion as a preparation for the final pass of the rotary speed mixer. The remaining specified quantity of fly ash shall be applied prior to the final pass of the rotary speed mixer. Mixing shall continue until a minimum 75 percent of the mixture is smaller than 25 mm (1 in.).

**302.09 Compaction.** Compaction of soil modified with portland cement, slag-modified portland cement, or fly ash shall be completed no later than one hour after mixing begins.

Compaction of soil modified with hydrated lime or by-product non-hydrated lime shall be completed within the same working day.

Compaction of soil modified with lime slurry shall begin within 24 hours.

Compaction of soil modified with by-product hydrated lime shall be delayed a minimum of 24 hours. The Engineer may require additional water or further mixing prior to the final compaction of soil modified with by-product hydrated lime. In no case shall compaction be started later than three days after mixing unless approved by the Engineer. If compaction is to be delayed, the surface of the soil shall be crown-graded and sealed from moisture loss by either blade dragging or light rolling immediately after mixing.

The compacted, modified soil shall have a minimum dry density of 95 percent of the laboratory standard dry density. The in place dry density will be determined according to AASHTO T 191, or Illinois Modified AASHTO T 310 (Direct Transmission Density/Backscatter Moisture). The laboratory standard dry density will be determined according to AASHTO T 99.

**302.10 Finishing and Curing.** When multiple lifts are used to construct the modified soil layer, the top lift shall be a minimum of 150 mm (6 in.) thick when compacted.

When compaction of the modified soil is nearing completion, the surface shall be shaped to the required lines, grades, and cross section shown on the plans. For bituminous concrete base course and pavement (full-depth) and portland cement concrete base course and pavement, the surface of the modified soil shall be brought to true shape and correct elevation according to Article 301.06, except that well compacted earth shall not be used to fill low areas.

Soils modified with portland cement, slag-modified portland cement, or fly ash shall be cured for a minimum of 24 hours. The ambient air temperature shall be above 7 °C (45 °F) during curing.

Soils modified with lime (slurry or dry) generally will not require curing unless the minimum stability requirements in Article 302.11 cannot be met. If it has been determined by the Engineer that curing is necessary, the curing requirements stated above shall apply.

During the curing period, the moisture content of the modified soil shall be maintained at optimum by sprinkling with water, use of plastic sheeting, or applying bituminous materials according to Article 312.19. During this period, no equipment or traffic will be permitted on the completed work beyond that required for maintenance of curing.

Equipment of such weight, or used in such a way as to cause a rut depth of 12 mm (0.5 in.) or more in the finished modified soil, shall be removed, or the rutting otherwise prevented, as directed by the Engineer.

**302.11 Subgrade Stability.** Following curing, or after compaction when no curing is performed, the Engineer will determine the stability of the modified soil in terms of the immediate bearing value (IBV), according to Illinois Test Procedure 501. The IBV shall be a minimum of 10.0.

No equipment or traffic shall be on the modified soil after compaction until the required IBV is attained.

**302.12 Method of Measurement.** This work will be measured for payment as follows.

(a) Contract Quantities. The requirements for the use of contract quantities shall conform to Article 202.07(a).



(b) Measured Quantities. Processing modified soils will be measured for payment in place and the area computed in square meters (square yards). The width for measurement will be as shown on the plans.

Modifier will be measured for payment in metric tons (tons). The modifier will be measured in trucks or freight cars. The Contractor shall furnish or arrange for use of scales of a type approved by the Engineer. When the modifier is shipped in trucks, it shall be measured at the place of loading, at the place of unloading, or at such other place as the Engineer may designate. The Engineer may accept original signed freight bills in lieu of determining the mass (weight).

Should the Contractor's method of construction require additional earth excavation or embankment due to requiring more than one lift to construct the modified soil layer as shown on the plans, this extra earth excavation and embankment will not be measured for payment.

**302.13 Basis of Payment.** This work will be paid for at the contract unit price per square meter (square yard) for PROCESSING MODIFIED SOIL, of the thickness specified; and per metric ton (ton) for LIME, FLY ASH, PORTLAND CEMENT, or SLAG-MODIFIED PORTLAND CEMENT."

80135

**SUBGRADE PREPARATION (BDE)**

Effective: November 1, 2002

Revise the tenth paragraph of Article 301.03 of the Standard Specifications to read:

“Equipment of such weight, or used in such a way as to cause a rut in the finished subgrade of 13 mm (1/2 in.) or more in depth, shall be removed from the work or the rutting otherwise prevented.”

80086

## **TRAFFIC CONTROL DEFICIENCY DEDUCTION (BDE)**

Effective: April 1, 1992  
Revised: January 1, 2005

To ensure a prompt response to incidents involving the integrity of work zone traffic control, the Contractor shall provide a telephone number where a responsible individual can be contacted 24 hours-a-day.

When the Engineer is notified, or determines a traffic control deficiency exists, he/she will notify and direct the Contractor to correct the deficiency within a specified time. The specified time, which begins upon notification to the Contractor, will be from 1/2 hour to 12 hours based upon the urgency of the situation and the nature of the deficiency. The Engineer shall be the sole judge.

A deficiency may be any lack of repair, maintenance, or non-compliance with the traffic control plan. A deficiency may also be applied to situations where corrective action is not an option such as the use of non-certified flaggers for short term operations; working with lane closures beyond the time allowed in the contract; or failure to perform required contract obligations such as traffic control surveillance.

If the Contractor fails to correct a deficiency within the specified time, a daily monetary deduction will be imposed for each calendar day or fraction thereof the deficiency exists. The calendar day(s) will begin with notification to the Contractor and end with the Engineer's acceptance of the correction. The daily monetary deduction will be either \$1,000 or 0.05 percent of the awarded contract value, whichever is greater. For those deficiencies where corrective action was not an option this monetary deduction will be immediate.

In addition, if the Contractor fails to respond, the Engineer may correct the deficiency and the cost thereof will be deducted from monies due or which may become due the Contractor. This corrective action will in no way relieve the Contractor of his/her contractual requirements or responsibilities.

5729I

## TRANSIENT VOLTAGE SURGE SUPPRESSION (BDE)

Effective: August 1, 2003

Revise the first paragraph of Article 1074.03(a)(4) of the Standard Specifications to read:

"(4) Transient Voltage Surge Suppression. The cabinet shall be provided with transient voltage surge suppression. Transient surge suppression unit leads shall be kept as short as possible and ground shall be made directly to the cabinet wall or ground plate as near as possible to the object being grounded. All transient surge suppression units shall be tested and certified as meeting this specification by an independent testing laboratory. One copy of each of the full testing report shall be submitted to the Engineer."

Revise Article 1074.03(a)(4)a. of the Standard Specifications to read:

- "a. Surge Suppressor. The suppressor protecting the solid state controller, conflict monitor, and detection equipment shall consist of two stages: stage one which shall include a controller cabinet AC power protection assembly and stage two which shall include AC circuit protection.

The design of the stage one suppressor shall be modular and it shall be installed in such a way that it may be removed and replaced with the intersection under power and in flashing operation. It shall have a permanently mounted and wired base and a removable circuit package. The stage one suppressor shall have two LED failure indicators for power 'on' and suppression 'failure' and shall meet the following properties:

Stage One Suppressor	
Properties	Criteria
"Plug-in" suppression module	12 pin connector assembly
Clamp voltage	250 V at 20,000 A typical
Response time	Less than 5 nanoseconds
Maximum continuous service current	15 A at 120 VAC 60 Hz
High frequency noise attenuation	At least 50 dB at 100,000 Hz
Operating temperature	-40 °C (-40 °F) to 85 °C (185 °F)

If the controller assembly includes a system telemetry module or remote intersection monitor, the status of the stage one suppressor shall be continuously and remotely monitored by an appropriate alarm circuit.

The stage two, high speed, solid state, transient suppressor shall protect the system from transient over voltage without affecting power at the load. It shall suppress transients of either polarity and from either direction (source or load). The suppressor shall have a visual "on" indicator lamp when the unit is operating normally. It shall also have a UL plastic enclosure, a four position terminal strip for

power connection, and it shall utilize silicon avalanche diode technology. The stage two suppressor shall meet the following properties:

Stage Two Suppressor	
Properties	Criteria
Nominal service voltage	120 V at 50/60 Hz
Maximum voltage protection level	$\pm 330$ V
Minimum voltage protection level	$\pm 220$ V $\pm 5\%$
Minimum surge current rating	700 A
Stand by power	Less than 0.5 Watts
Hot to neutral leakage current at 120 V RMS	Less than $5\mu$ A
Maximum response time	5 nanoseconds
Operating and Storage temperature	-20 °C (-4 °F) to 50 °C (122 °F)"

80107m

**TRUCK BED RELEASE AGENT (BDE)**

Effective: April 1, 2004

Add the following sentence after the third sentence of the first paragraph of Article 406.14 of the Standard Specifications.

"In addition to the release agent, the Contractor may use a light scatter of manufactured sand (FA 20 or FA 21) evenly distributed over the bed of the vehicle."

80123

## WEIGHT CONTROL DEFICIENCY DEDUCTION (BDE)

Effective: April 1, 2001

Revised: August 1, 2002

The Contractor shall provide accurate weights of materials delivered to the contract for incorporation into the work (whether temporary or permanent) and for which the basis of payment is by weight. These weights shall be documented on delivery tickets which shall identify the source of the material, type of material, the date and time the material was loaded, the contract number, the net weight, the tare weight when applicable and the identification of the transporting vehicle. For aggregates, the Contractor shall have the driver of the vehicle furnish or establish an acceptable alternative to provide the contract number and a copy of the material order to the source for each load. The source is defined as that facility that produces the final material product that is to be incorporated into the contract pay items.

The Department will conduct random, independent vehicle weight checks for material sources according to the procedures outlined in the Documentation Section Policy Statement of the Department's Construction Manual and hereby incorporated by reference. The results of the independent weight checks shall be applicable to all contracts containing this Special Provision. Should the vehicle weight check for a source result in the net weight of material on the vehicle exceeding the net weight of material shown on the delivery ticket by 0.50% (0.70% for aggregates) or more, the Engineer will document the independent vehicle weight check and immediately furnish a copy of the results to the Contractor. No adjustment in pay quantity will be made. Should the vehicle weight check for a source result in the net weight of material shown on the delivery ticket exceeding the net weight of material on the vehicle by 0.50% (0.70% for aggregates) or more, the Engineer will document the independent vehicle weight check and immediately furnish a copy of the results to the Contractor. The Engineer will adjust the net weight shown on the delivery ticket to the checked delivered net weight as determined by the independent vehicle weight check.

The Engineer will also adjust the method of measurement for all contracts for subsequent deliveries of all materials from the source based on the independent weight check. The net weight of all materials delivered to all contracts containing this Special Provision from this source, for which the basis of payment is by weight, will be adjusted by applying a correction factor "A" as determined by the following formula:

$$A = 1.0 - \left( \frac{B - C}{B} \right); \text{ Where } A \leq 1.0; \left( \frac{B - C}{C} \right) > 0.50\% \text{ (0.70\% for aggregates)}$$

Where A = Adjustment factor

B = Net weight shown on delivery ticket

C = Net weight determined from independent weight check

The adjustment factor will be applied as follows:

$$\text{Adjusted Net Weight} = A \times \text{Delivery Ticket Net Weight}$$

The adjustment factor will be imposed until the cause of the deficient weight is identified and corrected by the Contractor to the satisfaction of the Engineer. If the cause of the deficient weight is not identified and corrected within seven (7) calendar days, the source shall cease delivery of all materials to all contracts containing this Special Provision for which the basis of payment is by weight.

Should the Contractor elect to challenge the results of the independent weight check, the Engineer will continue to document the weight of material for which the adjustment factor would be applied. However, provided the Contractor furnishes the Engineer with written documentation that the source scale has been calibrated within seven (7) calendar days after the date of the independent weight check, adjustments in the weight of material paid for will not be applied unless the scale calibration demonstrates that the source scale was not within the specified Department of Agriculture tolerance.

At the Contractor's option, the vehicle may be weighed on a second independent Department of Agriculture certified scale to verify the accuracy of the scale used for the independent weight check.

80048



## **WORK ZONE TRAFFIC CONTROL DEVICES (BDE)**

Effective: January 1, 2003

Revised: November 1, 2004

Add the following to Article 702.01 of the Standard Specifications:

"All devices and combinations of devices shall meet the requirements of the National Cooperative Highway Research Program (NCHRP) Report 350 for their respective categories. The categories are as follows:

Category 1 includes small, lightweight, channelizing and delineating devices that have been in common use for many years and are known to be crashworthy by crash testing of similar devices or years of demonstrable safe performance. These include cones, tubular markers, flexible delineators and plastic drums with no attachments. Category 1 devices shall be crash tested and accepted or may be self-certified by the manufacturer.

Category 2 includes devices that are not expected to produce significant vehicular velocity change but may otherwise be hazardous. These include drums and vertical panels with lights, barricades and portable sign supports. Category 2 devices shall be crash tested and accepted for Test Level 3.

Category 3 includes devices that are expected to cause significant velocity changes or other potentially harmful reactions to impacting vehicles. These include crash cushions, truck mounted attenuators and other devices not meeting the definitions of Category 1 or 2. Category 3 devices shall be crash tested and accepted for either Test Level 3 or the test level specified.

Category 4 includes portable or trailer-mounted devices such as arrow boards, changeable message signs, temporary traffic signals and area lighting supports. Currently, there is no implementation date set for this category and it is exempt from the NCHRP 350 compliance requirement.

The Contractor shall provide a manufacturer's self-certification letter for each Category 1 device and an FHWA acceptance letter for each Category 2 and Category 3 device used on the contract. The letters shall state the device meets the NCHRP 350 requirements for its respective category and test level, and shall include a detail drawing of the device."

Delete the third, fourth and fifth paragraphs of Article 702.03(b) of the Standard Specifications.

Delete the third sentence of the first paragraph of Article 702.03(c) of the Standard Specifications.

Revise the first sentence of the first paragraph of Article 702.03(e) of the Standard Specifications to read:

"Drums shall be nonmetallic and have alternating reflectorized Type AA or Type AP fluorescent orange and reflectorized white horizontal, circumferential stripes."

Add the following to Article 702.03 of the Standard Specifications:

"(h) Vertical Barricades. Vertical barricades may be used in lieu of cones, drums or Type II barricades to channelize traffic."

Delete the fourth paragraph of Article 702.05(a) of the Standard Specifications.

Revise the sixth paragraph of Article 702.05(a) of the Standard Specifications to read:

"When the work operations exceed four days, all signs shall be post mounted unless the signs are located on the pavement or define a moving or intermittent operation. When approved by the Engineer, a temporary sign stand may be used to support a sign at 1.2 m (5 ft) minimum where posts are impractical. Longitudinal dimensions shown on the plans for the placement of signs may be increased up to 30 m (100 ft) to avoid obstacles, hazards or to improve sight distance, when approved by the Engineer. "ROAD CONSTRUCTION AHEAD" signs will also be required on side roads located within the limits of the mainline "ROAD CONSTRUCTION AHEAD" signs."

Delete all references to "Type 1A barricades" and "wing barricades" throughout Section 702 of the Standard Specifications.

80097

**WORKING DAYS (BDE)**

Effective: January 1, 2002

The Contractor shall complete the work within **25** working days.

80071

**REQUIRED CONTRACT PROVISIONS  
FEDERAL-AID CONSTRUCTION CONTRACTS**

	Page
I. General .....	1
II. Nondiscrimination .....	1
III. Nonsegregated Facilities .....	3
IV. Payment of Predetermined Minimum Wage.....	3
V. Statements and Payrolls .....	6
VI. Record of Materials, Supplies, and Labor.....	7
VIII. Safety: Accident Prevention .....	7
IX. False Statements Concerning Highway Projects.....	7
X. Implementation of Clean Air Act and Federal Water Pollution Control Act .....	8
XI. Certification Regarding Debarment, Suspension, Ineligibility, and Voluntary Exclusion .....	8
XII. Certification Regarding Use of Contract Funds for Lobbying .....	9

**ATTACHMENTS**

- A. Employment Preference for Appalachian Contracts  
(included in Appalachian contracts only)

**I. GENERAL**

1. These contract provisions shall apply to all work performed on the contract by the contractor's own organization and with the assistance of workers under the contractor's immediate superintendence and to all work performed on the contract by piecework, station work, or by subcontract.

2. Except as otherwise provided for in each section, the contractor shall insert in each subcontract all of the stipulations contained in these Required Contract Provisions, and further require their inclusion in any lower tier subcontract or purchase order that may in turn be made. The Required Contract Provisions shall not be incorporated by reference in any case. The prime contractor shall be responsible for compliance by any subcontractor or lower tier subcontractor with these Required Contract Provisions.

3. A breach of any of the stipulations contained in these Required Contract Provisions shall be sufficient grounds for termination of the contract.

4. A breach of the following clauses of the Required Contract Provisions may also be grounds for debarment as provided in 29 CFR 5.12:

- Section I, paragraph 2;
- Section IV, paragraphs 1, 2, 3, 4 and 7;
- Section V, paragraphs 1 and 2a through 2g.

5. Disputes arising out of the labor standards provisions of Section IV (except paragraph 5) and Section V of these Required Contract Provisions shall not be subject to the general disputes clause of this contract. Such disputes shall be resolved in accordance with the procedures of the U.S. Department of Labor (DOL) as set forth in 29 CFR 5, 6 and 7. Disputes within the meaning of this clause include disputes between the contractor (or any of its subcontractors) and the contracting agency, the DOL, or the contractor's employees or their representatives.

6. Selection of Labor: During the performance of this contract, the contractor shall not:

- a. Discriminate against labor from any other State, possession, or territory of the United States (except for employment preference for Appalachian contracts, when applicable, as specified in Attachment A), or
- b. Employ convict labor for any purpose within the limits of the project unless it is labor performed by convicts who are on parole, supervised release, or probation.

**II. NONDISCRIMINATION**

1. Equal Employment Opportunity: Equal employment opportunity (EEO) requirements not to discriminate and to take affirmative action to assure equal opportunity as set forth under laws, executive orders, rules, regulations (28 CFR 35, 29 CFR 1630 and 41 CFR 60 (and orders of the Secretary of Labor as modified by the provisions prescribed herein, and imposed pursuant to 23 U.S.C. 140 shall constitute the EEO and specific affirmative action standards for the contractor's project activities under this contract. The Equal Opportunity Construction Contract Specifications set forth under 41 CFR 60-4.3 and the provisions of the American Disabilities Act of 1990 (42 U.S.C. 12101 et seq.) set forth under 28 CFR 35 and 29 CFR 1630 are incorporated by reference in this contract. In the execution of this contract, the contractor agrees to comply with the following minimum specific requirement activities of EEO:

a. The contractor will work with the State highway agency (SHA) and the Federal Government in carrying out EEO obligations and in their review of his/her activities under the contract.

b. The contractor will accept as his operating policy the following statement:

"It is the policy of this Company to assure that applicants are employed, and that employees are treated during employment, without regard to their race, religion, sex, color, national origin, age or disability. Such action shall include: employment, upgrading, demotion, or transfer; recruitment or recruitment advertising; layoff or termination; rates of pay or other forms of compensation; and selection for training, including apprenticeship, preapprenticeship, and/or on-the-job-training."

2. EEO Officer: The contractor will designate and make known to the SHA contracting officers an EEO Officer who will have the responsibility for an must be capable of effectively administering and promoting an active contractor program of EEO and who must be assigned adequate authority and responsibility to do so.

3. Dissemination of Policy: All members of the contractor's staff who are authorized to hire, supervise, promote, and discharge employees, or who recommend such action, or who are substantially involved in such action, will be made fully cognizant of, and will implement, the contractor's EEO policy and contractual responsibilities to provide EEO in each grade and classification of employment. To ensure that the above

agreement will be met, the following actions will be taken as a minimum:

a. Periodic meetings of supervisory and personnel office employees will be conducted before the start of work and then not less often than once every six months, at which time the contractor's EEO policy and its implementation will be reviewed and explained. The meetings will be conducted by the EEO Officer.

b. All new supervisory or personnel office employees will be given a thorough indoctrination by the EEO Officer, covering all major aspects of the contractor's EEO obligations within thirty days following their reporting for duty with the contractor.

c. All personnel who are engaged in direct recruitment for the project will be instructed by the EEO Officer in the contractor's procedures for locating and hiring minority group employees.

d. Notices and posters setting forth the contractor's EEO policy will be placed in areas readily accessible to employees, applicants for employment and potential employees.

e. The contractor's EEO policy and the procedures to implement such policy will be brought to the attention of employees by means of meetings, employee handbooks, or other appropriate means.

4. Recruitment: When advertising for employees, the contractor will include in all advertisements for employees the notation: "An Equal Opportunity Employer." All such advertisements will be placed in publications having a large circulation among minority groups in the area from which the project work force would normally be derived.

a. The contractor will, unless precluded by a valid bargaining agreement, conduct systematic and direct recruitment through public and private employees referral sources likely to yield qualified minority group applicants. To meet this requirement, the contractor will identify sources of potential minority group employees, and establish which such identified sources procedures whereby minority group applicants may be referred to the contractor for employment consideration.

b. In the event the contractor has a valid bargaining agreement providing for exclusive hiring hall referrals, he is expected to observe the provisions of that agreement to the extent that the system permits the contractor's compliance with EEO contract provisions. (The DOL has held that where implementation of such agreements have the effect of discriminating against minorities or women, or obligates the contractor to do the same, such implementation violates Executive Order 11246, as amended.)

c. The contractor will encourage his present employees to refer minority group applicants for employment. Information and procedures with regard to referring minority group applicants will be discussed with employees.

5. Personnel Actions: Wages, working conditions, and employee benefits shall be established and administered, and personnel actions of every type, including hiring, upgrading, promotion, transfer, demotion, layoff, and termination, shall be taken without regard to race, color, religion, sex, national origin, age or disability. The following procedures shall be followed:

a. The contractor will conduct periodic inspections of project sites to insure that working conditions and employee facilities do not indicate discriminatory treatment of project site personnel.

b. The contractor will periodically evaluate the spread of wages paid within each classification to determine any

evidence of discriminatory wage practices.

c. The contractor will periodically review selected personnel actions in depth to determine whether there is evidence of discrimination. Where evidence is found, the contractor will promptly take corrective action. If the review indicates that the discrimination may extend beyond the actions reviewed, such corrective action shall include all affected persons.

d. The contractor will promptly investigate all complaints of alleged discrimination made to the contractor in connection with his obligations under this contract, will attempt to resolve such complaints, and will take appropriate corrective action within a reasonable time. If the investigation indicates that the discrimination may affect persons other than the complainant, such corrective action shall include such other persons. Upon completion of each investigation, the contractor will inform every complainant of all of his avenues of appeal.

6. Training and Promotion:

a. The contractor will assist in locating, qualifying, and increasing the skills of minority group and women employees, and applicants for employment.

b. Consistent with the contractor's work force requirements and as permissible under Federal and State regulations, the contractor shall make full use of training programs, i.e., apprenticeship, and on-the-job training programs for the geographical area of contract performance. Where feasible, 25 percent of apprentices or trainees in each occupation shall be in their first year of apprenticeship or training. In the event a special provision for training is provided under this contract, this subparagraph will be superseded as indicated in the special provision.

c. The contractor will advise employees and applicants for employment of available training programs and entrance requirements for each.

d. The contractor will periodically review the training and promotion potential of minority group and women employees and will encourage eligible employees to apply for such training and promotion.

7. Unions: If the contractor relies in whole or in part upon unions as a source of employees, the contractor will use his/her best efforts to obtain the cooperation of such unions to increase opportunities for minority groups and women within the unions, and to effect referrals by such unions of minority and female employees. Actions by the contractor either directly or through a contractor's association acting as agent will include the procedures set forth below:

a. The contractor will use best efforts to develop, in cooperation with the unions, joint training programs aimed toward qualifying more minority group members and women for membership in the unions and increasing the skills of minority group employees and women so that they may qualify for higher paying employment.

b. The contractor will use best efforts to incorporate an EEO clause into each union agreement to the end that such union will be contractually bound to refer applicants without regard to their race, color, religion, sex, national origin, age or disability.

c. The contractor is to obtain information as to the referral practices and policies of the labor union except that to the extent such information is within the exclusive possession of the labor union and such labor union refuses to furnish such information to the contractor, the contractor shall so certify to

the SHA and shall set forth what efforts have been made to obtain such information.

d. In the event the union is unable to provide the contractor with a reasonable flow of minority and women referrals within the time limit set forth in the collective bargaining agreement, the contractor will, through independent recruitment efforts, fill the employment vacancies without regard to race, color, religion, sex, national origin, age or disability; making full efforts to obtain qualified and/or quailifiable minority group persons and women. (The DOL has held that it shall be no excuse that the union with which the contractor has a collective bargaining agreement providing for exclusive referral failed to refer minority employees.) In the event the union referral practice prevents the contractor from meeting the obligations pursuant to Executive Order 11246, as amended, and these special provisions, such contractor shall immediately notify the SHA.

8. Selection of Subcontractors, Procurement of Materials and Leasing of Equipment: The contractor shall not discriminate on the grounds of race, color, religion, sex, national origin, age or disability in the selection and retention of subcontractors, including procurement of materials and leases of equipment.

a. The contractor shall notify all potential subcontractors and suppliers of his/her EEO obligations under this contract.

b. Disadvantaged business enterprises (DBE), as defined in 49 CFR 23, shall have equal opportunity to compete for and perform subcontracts which the contractor enters into pursuant to this contract. The contractor will use his best efforts to solicit bids from and to utilize DBE subcontractors or subcontractors with meaningful minority group and female representation among their employees. Contractors shall obtain lists of DBE construction firms from SHA personnel.

c. The contractor will use his best efforts to ensure subcontractor compliance with their EEO obligations.

9. Records and Reports: The contractor shall keep such records as necessary to document compliance with the EEO requirements. Such records shall be retained for a period of three years following completion of the contract work and shall be available at reasonable times and places for inspection by authorized representatives of the SHA and the FHWA.

a. The records kept by the contractor shall document the following:

(1) The number of minority and non-minority group members and women employed in each work classification on the project;

(2) The progress and efforts being made in cooperation with unions, when applicable, to increase employment opportunities for minorities and women;

(3) The progress and efforts being made in locating, hiring, training, qualifying, and upgrading minority and female employees; and

(4) The progress and efforts being made in securing the services of DBE subcontractors or subcontractors with meaningful minority and female representation among their employees.

b. The contractors will submit an annual report to the SHA each July for the duration of the project, indicating the number of minority, women, and non-minority group employees currently engaged in each work classification required by the contract work. This information is to be reported on Form FHWA-1391. If on-the-job training is being required by special provision, the contractor will be required to collect and report training data.

### III. NONSEGREGATED FACILITIES

(Applicable to all Federal-aid construction contracts and to all related subcontracts of \$10,000 or more.)

a. By submission of this bid, the execution of this contract or subcontract, or the consummation of this material supply agreement or purchase order, as appropriate, the bidder, Federal-aid construction contractor, subcontractor, material supplier, or vendor, as appropriate, certifies that the firm does not maintain or provide for its employees any segregated facilities at any of its establishments, and that the firm does not permit its employees to perform their services at any location, under its control, where segregated facilities are maintained. The firm agrees that a breach of this certification is a violation of the EEO provisions of this contract. The firm further certifies that no employee will be denied access to adequate facilities on the basis of sex or disability.

b. As used in this certification, the term "segregated facilities" means any waiting rooms, work areas, restrooms and washrooms, restaurants and other eating areas, timeclocks, locker rooms, and other storage or dressing areas, parking lots, drinking fountains, recreation or entertainment areas, transportation, and housing facilities provided for employees which are segregated by explicit directive, or are, in fact, segregated on the basis of race, color, religion, national origin, age or disability, because of habit, local custom, or otherwise. The only exception will be for the disabled when the demands for accessibility override (e.g. disabled parking).

c. The contractor agrees that it has obtained or will obtain identical certification from proposed subcontractors or material suppliers prior to award of subcontracts or consummation of material supply agreements of \$10,000 or more and that it will retain such certifications in its files.

### IV. PAYMENT OF PREDETERMINED MINIMUM WAGE

(Applicable to all Federal-aid construction contracts exceeding \$2,000 and to all related subcontracts, except for projects located on roadways classified as local roads or rural minor collectors, which are exempt.)

#### 1. General:

a. All mechanics and laborers employed or working upon the site of the work will be paid unconditionally and not less often than once a week and without subsequent deduction or rebate on any account [except such payroll deductions as are permitted by regulations (29 CFR 3) issued by the Secretary of Labor under the Copeland Act (40 U.S.C. 276c)] the full amounts of wages and bona fide fringe benefits (or cash equivalents thereof) due at time of payment. The payment shall be computed at wage rates not less than those contained in the wage determination of the Secretary of Labor (hereinafter "the wage determination") which is attached hereto and made a part hereof, regardless of any contractual relationship which may be alleged to exist between the

contractor or its subcontractors and such laborers and mechanics. The wage determination (including any additional classifications and wage rates conformed under paragraph 2 of this Section IV and the DOL poster (WH-1321) or Form FHWA-1495) shall be posted at all times by the contractor and its subcontractors at the site of the work in a prominent and accessible place where it can be easily seen by the workers. For the purpose of this Section, contributions made or costs reasonably anticipated for bona fide fringe benefits under Section 1(b)(2) of the Davis-Bacon Act (40 U.S.C. 276a) on behalf of laborers or mechanics are considered wages paid to such laborers or mechanics, subject to the provisions of Section IV, paragraph 3b, hereof. Also, for the purpose of this Section, regular contributions made or costs incurred for more than a weekly period (but not less often than quarterly) under plans, funds, or programs, which cover the particular weekly period, are deemed to be constructively made or incurred during such weekly period. Such laborers and mechanics shall be paid the appropriate wage rate and fringe benefits on the wage determination for the classification of work actually performed, without regard to skill, except as provided in paragraphs 4 and 5 of this Section IV.

b. Laborers or mechanics performing work in more than one classification may be compensated at the rate specified for each classification for the time actually worked therein, provided, that the employer's payroll records accurately set forth the time spent in each classification in which work is performed.

c. All rulings and interpretations of the Davis-Bacon Act and related acts contained in 29 CFR 1, 3, and 5 are herein incorporated by reference in this contract.

## 2. Classification:

a. The SHA contracting officer shall require that any class of laborers or mechanics employed under the contract, which is not listed in the wage determination, shall be classified in conformance with the wage determination.

b. The contracting officer shall approve an additional classification, wage rate and fringe benefits only when the following criteria have been met:

(1) the work to be performed by the additional classification requested is not performed by a classification in the wage determination;

(2) the additional classification is utilized in the area by the construction industry;

(3) the proposed wage rate, including any bona fide fringe benefits, bears a reasonable relationship to the wage rates contained in the wage determination; and

(4) with respect to helpers, when such a classification prevails in the area in which the work is performed.

c. If the contractor or subcontractors, as appropriate, the laborers and mechanics (if known) to be employed in the additional classification or their representatives, and the contracting officer agree on the classification and wage rate (including the amount designated for fringe benefits where appropriate), a report of the action taken shall be sent by the contracting officer to the DOL, Administrator of the Wage and Hour Division, Employment Standards Administration, Washington, D.C. 20210. The Wage and Hour Administrator, or an authorized representative, will approve, modify, or

disapprove every additional classification action within 30 days of receipt and so advise the contracting officer or will notify the contracting officer within the 30-day period that additional time is necessary.

d. In the event the contractor or subcontractors, as appropriate, the laborers or mechanics to be employed in the additional classification or their representatives, and the contracting officer do not agree on the proposed classification and wage rate (including the amount designated for fringe benefits, where appropriate), the contracting officer shall refer the question, including the views of all interested parties and the recommendation of the contracting officer, to the Wage and Hour Administrator for determination. Said Administrator, or an authorized representative, will issue a determination within 30 days of receipt and so advise the contracting officer or will notify the contracting officer within the 30-day period that additional time is necessary.

e. The wage rate (including fringe benefits where appropriate) determined pursuant to paragraph 2c or 2d of this Section IV shall be paid to all workers performing work in the additional classification from the first day on which work is performed in the classification.

## 3. Payment of Fringe Benefits:

a. Whenever the minimum wage rate prescribed in the contract for a class of laborers or mechanics includes a fringe benefit which is not expressed as an hourly rate, the contractor or subcontractors, as appropriate, shall either pay the benefit as stated in the wage determination or shall pay another bona fide fringe benefit or an hourly case equivalent thereof.

b. If the contractor or subcontractor, as appropriate, does not make payments to a trustee or other third person, he/she may consider as a part of the wages of any laborer or mechanic the amount of any cost reasonably anticipated in providing bona fide fringe benefits under a plan or program, provided that the Secretary of Labor has found, upon the written request of the contractor, that the applicable standards of the Davis-Bacon Act have been met. The Secretary of Labor may require the contractor to set aside in a separate account assets for the meeting of obligations under the plan or program.

## 4. Apprentices and Trainees (Programs of the U.S. DOL) and Helpers:

### a. Apprentices:

(1) Apprentices will be permitted to work at less than the predetermined rate for the work they performed when they are employed pursuant to and individually registered in a bona fide apprenticeship program registered with the DOL, Employment and Training Administration, Bureau of Apprenticeship and Training, or with a State apprenticeship agency recognized by the Bureau, or if a person is employed in his/her first 90 days of probationary employment as an apprentice in such an apprenticeship program, who is not individually registered in the program, but who has been certified by the Bureau of Apprenticeship and Training or a State apprenticeship agency (where appropriate) to be eligible for probationary employment as an apprentice.

(2) The allowable ratio of apprentices to journeyman-level employees on the job site in any craft classification shall not

be greater than the ratio permitted to the contractor as to the entire work force under the registered program. Any employee listed on a payroll at an apprentice wage rate, who is not registered or otherwise employed as stated above, shall be paid not less than the applicable wage rate listed in the wage determination for the classification of work actually performed. In addition, any apprentice performing work on the job site in excess of the ratio permitted under the registered program shall be paid not less than the applicable wage rate on the wage determination for the work actually performed. Where a contractor or subcontractor is performing construction on a project in a locality other than that in which its program is registered, the ratios and wage rates (expressed in percentages of the journeyman-level hourly rate) specified in the contractor's or subcontractor's registered program shall be observed.

(3) Every apprentice must be paid at not less than the rate specified in the registered program for the apprentice's level of progress, expressed as a percentage of the journeyman-level hourly rate specified in the applicable wage determination. Apprentices shall be paid fringe benefits in accordance with the provisions of the apprenticeship program. If the apprenticeship program does not specify fringe benefits, apprentices must be paid the full amount of fringe benefits listed on the wage determination for the applicable classification. If the Administrator for the Wage and Hour Division determines that a different practice prevails for the applicable apprentice classification, fringes shall be paid in accordance with that determination.

(4) In the event the Bureau of Apprenticeship and Training, or a State apprenticeship agency recognized by the Bureau, withdraws approval of an apprenticeship program, the contractor or subcontractor will no longer be permitted to utilize apprentices at less than the applicable predetermined rate for the comparable work performed by regular employees until an acceptable program is approved.

b. Trainees:

(1) Except as provided in 29 CFR 5.16, trainees will not be permitted to work at less than the predetermined rate for the work performed unless they are employed pursuant to and individually registered in a program which has received prior approval, evidenced by formal certification by the DOL, Employment and Training Administration.

(2) The ratio of trainees to journeyman-level employees on the job site shall not be greater than permitted under the plan approved by the Employment and Training Administration. Any employee listed on the payroll at a trainee rate who is not registered and participating in a training plan approved by the Employment and Training Administration shall be paid not less than the applicable wage rate on the wage determination for the classification of work actually performed. In addition, any trainee performing work on the job site in excess of the ratio permitted under the registered program shall be paid not less than the applicable wage rate on the wage determination for the work actually performed.

(3) Every trainee must be paid at not less than the rate specified in the approved program for his/her level of progress, expressed as a percentage of the journeyman-level hourly rate specified in the applicable wage determination. Trainees shall be paid fringe benefits in accordance with the provisions of the trainee program. If the trainee program does not mention fringe benefits, trainees shall be paid the full amount of fringe benefits

Wage and Hour Division determines that there is an apprenticeship program associated with the corresponding journeyman-level wage rate on the wage determination which provides for less than full fringe benefits for apprentices, in which cases such trainees shall receive the same fringe benefits as apprentices.

(4) In the event the Employment and Training Administration withdraws approval of a training program, the contractor or subcontractor will no longer be permitted to utilize trainees at less than the applicable predetermined rate for the work performed until an acceptable program is approved.

c. Helpers:

Helpers will be permitted to work on a project if the helper classification is specified and defined on the applicable wage determination or is approved pursuant to the conformance procedure set forth in Section IV. 2. Any worker listed on a payroll at a helper wage rate, who is not a helper under a approved definition, shall be paid not less than the applicable wage rate on the wage determination for the classification of work actually performed.

5. Apprentices and Trainees (Programs of the U.S. DOT):

Apprentices and trainees working under apprenticeship and skill training programs which have been certified by the Secretary of Transportation as promoting EEO in connection with Federal-aid highway construction programs are not subject to the requirements of paragraph 4 of this Section IV. The straight time hourly wage rates for apprentices and trainees under such programs will be established by the particular programs. The ratio of apprentices and trainees to journeymen shall not be greater than permitted by the terms of the particular program.

6. Withholding:

The SHA shall upon its own action or upon written request of an authorized representative of the DOL withhold, or cause to be withheld, from the contractor or subcontractor under this contract or any other Federal contract with the same prime contractor or any other Federally-assisted contract subject to Davis-Bacon prevailing wage requirements which is held by the same prime contractor, as much of the accrued payments or advances as may be considered necessary to pay laborers and mechanics, including apprentices, trainee's and helpers, employed by the contractor or any subcontractor the full amount of wages required by the contract. In the event of failure to pay any laborer or mechanic, including any apprentice, trainee, or helper, employed or working on the site of the work, all or part of the wages required by the contract, the SHA contracting officer may, after written notice to the contractor, take such action as may be necessary to cause the suspension of any further payment, advance, or guarantee of funds until such violations have ceased.

7. Overtime Requirements:

No contractor or subcontractor contracting for any part of the contract work which may require or involve the employment of laborers, mechanics, watchmen, or guards (including apprentices, trainees, and helpers described in paragraphs 4 and 5 above) shall require or permit any laborer, mechanic, watchman, or guard in any workweek in which he/she is employed on such work, to work in excess of 40 hours in such workweek unless such laborer, mechanic, watchman, or guard receives compensation at a rate not less than one-and-one-half times his/her basic rate of pay for all hours worked in excess of 40 hours in such workweek.



## 8. Violation:

Liability for Unpaid Wages; Liquidated Damages: In the event of any violation of the clause set forth in paragraph 7 above, the contractor and any subcontractor responsible thereof shall be liable to the affected employee for his/her unpaid wages. In addition, such contractor and subcontractor shall be liable to the United States (in the case of work done under contract for the District of Columbia or a territory, to such District or to such territory) for liquidated damages. Such liquidated damages shall be computed with respect to each individual laborer, mechanic, watchman, or guard employed in violation of the clause set forth in paragraph 7, in the sum of \$10 for each calendar day on which such employee was required or permitted to work in excess of the standard work week of 40 hours without payment of the overtime wages required by the clause set forth in paragraph 7.

## 9. Withholding for Unpaid Wages and Liquidated Damages:

The SHA shall, upon its own action or upon written request of any authorized representative of the DOL withhold, or cause to be withheld, from any monies payable on account of work performed by the contractor or subcontractor under any such contract or any other Federal contract with the same prime contractor, or any other Federally-assisted contract subject to the Contract Work Hours and Safety Standards Act, which is held by the same prime contractor, such sums as may be determined to be necessary to satisfy any liabilities of such contractor or subcontractor for unpaid wages and liquidated damages as provided in the clause set forth in paragraph 8 above.

## V. STATEMENTS AND PAYROLLS

(Applicable to all Federal-aid construction contracts exceeding \$2,000 and to all related subcontracts, except for projects located on roadways classified as local roads or rural collectors, which are exempt.)

### 1. Compliance with Copeland Regulations (29 CFR 3):

The contractor shall comply with the Copeland Regulations of the Secretary of Labor which are herein incorporated by reference.

### 2. Payrolls and Payroll Records:

a. Payrolls and basic records relating thereto shall be maintained by the contractor and each subcontractor during the course of the work and preserved for a period of 3 years from the date of completion of the contract for all laborers, mechanics, apprentices, trainees, watchmen, helpers, and guards working at the site of the work.

b. The payroll records shall contain the name, social security number, and address of each such employee; his or her correct classification; hourly rates of wages paid (including rates of contributions or costs anticipated for bona fide fringe benefits or cash equivalent thereof the types described in Section 1(b)(2)(B) of the Davis Bacon Act); daily and weekly number of hours worked; deductions made; and actual wages paid. In addition, for Appalachian contracts, the payroll records shall contain a notation indicating whether the employee does, or does not, normally reside in the labor area as defined in Attachment A, paragraph 1. Whenever the Secretary of Labor, pursuant to Section IV, paragraph 3b, has found that the wages of any laborer or mechanic include the amount of any costs reasonably anticipated in providing benefits under a plan

or program described in Section 1(b)(2)(B) of the Davis Bacon Act, the contractor and each subcontractor shall maintain records which show that the commitment to provide such benefits is enforceable, that the plan or program is financially responsible, that the plan or program has been communicated in writing to the laborers or mechanics affected, and show the cost anticipated or the actual cost incurred in providing benefits. Contractors or subcontractors employing apprentices or trainees under approved programs shall maintain written evidence of the registration of apprentices and trainees, and ratios and wage rates prescribed in the applicable programs.

c. Each contractor and subcontractor shall furnish, each week in which any contract work is performed, to the SHA resident engineer a payroll of wages paid each of its employees (including apprentices trainees, and helpers, described in Section IV, paragraphs 4 and 5, and watchmen and guards engaged on work during the preceding weekly payroll period).

The payroll submitted shall set out accurately and completely all of the information required to be maintained under paragraph 2b of this Section V.

This information may be submitted in any form desired. Optional Form WH-347 is available for this purpose and may be purchased from the Superintendent of Documents (Federal stock number 029-005-0014-1), U.S. Government Printing Office, Washington, D.C. 20402. The prime contractor is responsible for the submission of copies of payrolls by all subcontractors.

d. Each payroll submitted shall be accompanied by a "Statement of Compliance," signed by the Contractor or subcontractor or his/her agent who pays or supervises the payment of the persons employed under the contract and shall certify the following:

(1) that the payroll for the payroll period contains the information required to be maintained under paragraph 2b of this Section V and that such information is correct and complete;

(2) that such laborer or mechanic (including each helper, apprentice, and trainee) employed on the contract during the payroll period has been paid the full weekly wages earned, without rebate, either directly or indirectly, and that no deductions have been made either directly or indirectly from the full wages earned, other than permissible deductions as set forth in the Regulations, 29 CFR 3;

(3) that each laborer or mechanic has been paid not less than the applicable wage rate and fringe benefits or cash equivalent for the classification of work performed, as specified in the applicable wage determination incorporated into the contract.

e. The weekly submission of a properly executed certification set forth on the reverse side of Optional Form WH-347 shall satisfy the requirement for submission of the "Statement of Compliance" required by paragraph 2d of this Section V.

f. The falsification of any of the above certifications may subject the contractor to civil or criminal prosecution under 18 U/S. C. 1001 and 31 U.S.C. 231.

g. The contractor or subcontractor shall make the records required under paragraph 2b of this Section V available for

inspection, copying, or transcription by authorized representatives of the SHA, the FHWA, or the DOL, and shall permit such representatives to interview employees during working hours on the job. If the contractor or subcontractor fails to submit the required records or to make them available, the SHA, the FHWA, the DOL, or all may, after written notice to the contractor, sponsor, applicant, or owner, take such actions as may be necessary to cause the suspension of any further payment, advance, or guarantee of funds. Furthermore, failure to submit the required records upon request or to make such records available may be grounds for debarment action pursuant to 29 CFR 5.12.

## **VI. RECORD OF MATERIALS, SUPPLIES, AND LABOR**

1. On all federal-aid contracts on the national highway system, except those which provide solely for the installation of protective devices at railroad grade crossings, those which are constructed on a force account or direct labor basis, highway beautification contracts, and contracts for which the total final construction cost for roadway and bridge is less than \$1,000,000 (23 CFR 635) the contractor shall:

a. Become familiar with the list of specific materials and supplies contained in Form FHWA-47, "Statement of Materials and Labor Used by Contractor of Highway Construction Involving Federal Funds," prior to the commencement of work under this contract.

b. Maintain a record of the total cost of all materials and supplies purchased for and incorporated in the work, and also of the quantities of those specific materials and supplies listed on Form FHWA-47, and in the units shown on Form FHWA-47.

c. Furnish, upon the completion of the contract, to the SHA resident engineer on Form FHWA-47 together with the data required in paragraph 1b relative to materials and supplies, a final labor summary of all contract work indicating the total hours worked and the total amount earned.

2. At the prime contractor's option, either a single report covering all contract work or separate reports for the contractor and for each subcontract shall be submitted.

## **VII. SUBLETTING OR ASSIGNING THE CONTRACT**

1. The contractor shall perform with its own organization contract work amounting to not less than 30 percent (or a greater percentage if specified elsewhere in the contract) of the total original contract price, excluding any specialty items designated by the State. Specialty items may be performed by subcontract and the amount of any such specialty items performed may be deducted from the total original contract price before computing the amount of work required to be performed by the contractor's own organization (23 CFR 635).

a. "Its own organization" shall be construed to include only workers employed and paid directly by the prime contractor and equipment owned or rented by the prime contractor, with or without operators. Such term does not include employees or equipment of a subcontractor, assignee, or agent of the prime contractor.

b. "Specialty Items" shall be construed to be limited to work that requires highly specialized knowledge, abilities, or equipment not ordinarily available in the type of contracting organizations qualified and expected to bid on the contract as a

whole and in general are to be limited to minor components of the overall contract.

2. The contract amount upon which the requirements set forth in paragraph 1 of Section VII is computed includes the cost of material and manufactured products which are to be purchased or produced by the contractor under the contract provisions.

3. The contractor shall furnish (a) a competent superintendent or supervisor who is employed by the firm, has full authority to direct performance of the work in accordance with the contract requirements, and is in charge of all construction operations (regardless of who performs the work) and (b) such other of its own organizational resources (supervision, management, and engineering services) as the SHA contracting officer determines is necessary to assure the performance of the contract.

4. No portion of the contract shall be sublet, assigned or otherwise disposed of except with the written consent of the SHA contracting officer, or authorized representative, and such consent when given shall not be construed to relieve the contractor of any responsibility for the fulfillment of the contract.

Written consent will be given only after the SHA has assured that each subcontract is evidenced in writing and that it contains all pertinent provisions and requirements of the prime contract.

## **VIII. SAFETY: ACCIDENT PREVENTION**

1. In the performance of this contract the contractor shall comply with all applicable Federal, State, and local laws governing safety, health, and sanitation (23 CFR 635). The contractor shall provide all safeguards, safety devices and protective equipment and take any other needed actions as it determines, or as the SHA contracting officer may determine, to be reasonably necessary to protect the life and health of employees on the job and the safety of the public and to protect property in connection with the performance of the work covered by the contract.

2. It is a condition of this contract, and shall be made a condition of each subcontract, which the contractor enters into pursuant to this contract, that the contractor and any subcontractor shall not permit any employee, in performance of the contract, to work in surroundings or under conditions which are unsanitary, hazardous or dangerous to his/her health or safety, as determined under construction safety and health standards (29 CFR 1926) promulgated by the Secretary of Labor, in accordance with Section 107 of the Contract Work Hours and Safety Standards Act (40 U.S.C. 333).

3. Pursuant to 29 CFR 1926.3, it is a condition of this contract that the Secretary of Labor or authorized representative thereof, shall have right of entry to any site of contract performance to inspect or investigate the matter of compliance with the construction safety and health standards and to carry out the duties of the Secretary under Section 107 of the Contract Work Hours and Safety Standards Act (40 U.S.C. 333).

## **IX. FALSE STATEMENTS CONCERNING HIGHWAY PROJECTS**

In order to assure high quality and durable construction in conformity with approved plans and specifications and a high degree of reliability on statements and representations made by engineers, contractors, suppliers, and workers on Federal-aid highway projects, it is essential that all persons concerned with the project perform their functions as carefully, thoroughly, and honestly as possible. Willful falsification,

distortion, or misrepresentation with respect to any facts related to the project is a violation of Federal law. To prevent any misunderstanding regarding the seriousness of these and similar acts, the following notice shall be posted on each Federal-aid highway project (23 CFR 635) in one or more places where it is readily available to all persons concerned with the project:

**NOTICE TO ALL PERSONNEL ENGAGED ON FEDERAL-AID HIGHWAY PROJECTS**

18 U.S.C. 1020 reads as follows:

*"Whoever, being an officer, agent or employee of the United States, or of any State or Territory, or whoever, whether a person, association, firm, or corporation, knowingly makes any false statement, false representation, or false report as to the character, quality, quantity, or cost of the material used or to be used, or the quantity or quality of the work performed or to be performed, or the cost thereof in connection with the submission of plans, maps, specifications, contracts, or costs of construction on any highway or related project submitted for approval to the Secretary of Transportation; or*

*Whoever knowingly makes any false statement, false representation, false report or false claim with respect to the character, quality, quantity, or cost of any work performed or to be performed, or materials furnished or to be furnished, in connection with the construction of any highway or related project approved by the Secretary of Transportation; or*

*Whoever knowingly makes any false statement or false representation as to material fact in any statement, certificate, or report submitted pursuant to provisions of the Federal-aid Roads Act approved July 1, 1916, (39 Stat. 355), as amended and supplemented;*

*Shall be fined not more than \$10,000 or imprisoned not more than 5 years or both."*

**X. IMPLEMENTATION OF CLEAN AIR ACT AND FEDERAL WATER POLLUTION CONTROL ACT**

(Applicable to all Federal-aid construction contracts and to all related subcontracts of \$100,000 or more).

By submission of this bid or the execution of this contract, or subcontract, as appropriate, the bidder, Federal-aid construction contractor, or subcontractor, as appropriate, will be deemed to have stipulated as follows:

1. That any facility that is or will be utilized in the performance of this contract, unless such contract is exempt under the Clean Air Act, as amended (42 U.S.C. 1857 et seq., as amended by Pub.L. 91-604), and under the Federal Water Pollution Control Act, as amended (33 U.S.C. 1251 et seq., as amended by Pub.L. 92-500), Executive Order 11738, and regulations in implementation thereof (40 CFR 15) is not listed, on the date of contract award, on the U.S. Environmental Protection Agency (EPA) List of Violating Facilities pursuant to 40 CFR 15.20.

2. That the firm agrees to comply and remain in compliance with all the requirements of Section 114 of the Clean Air Act and Section 308 of the Federal Water Pollution Control Act and all regulations and guidelines listed thereunder.

3. That the firm shall promptly notify the SHA of the receipt of

any communication from the Director, Office of Federal Activities, EPA indicating that a facility that is or will be utilized for the contract is under consideration to be listed on the EPA List of Violating Facilities.

4. That the firm agrees to include or cause to be included the requirements of paragraph 1 through 4 of this Section X in every nonexempt subcontract, and further agrees to take such action as the government may direct as a means of enforcing such requirements.

**XI. CERTIFICATION REGARDING DEBARMENT, SUSPENSION, INELIGIBILITY AND VOLUNTARY EXCLUSION**

1. Instructions for Certification - Primary Covered Transactions:

(Applicable to all Federal-aid contracts - 49 CFR 29)

a. By signing and submitting this proposal, the prospective primary participant is providing the certification set out below.

b. The inability of a person to provide the certification set out below will not necessarily result in denial of participation in this covered transaction. The prospective participant shall submit an explanation of why it cannot provide the certification set out below. The certification or explanation will be considered in connection with the department or agency's determination whether to enter into this transaction. However, failure of the prospective primary participant to furnish a certification or an explanation shall disqualify such a person from participation in this transaction.

c. The certification in this clause is a material representation of fact upon which reliance was placed when the department or agency determined to enter into this transaction. If it is later determined that the prospective primary participant knowingly rendered an erroneous certification, in addition to other remedies available to the Federal Government, the department or agency may terminate this transaction for cause of default.

d. The prospective primary participant shall provide immediate written notice to the department or agency to whom this proposal is submitted if any time the prospective primary participant learns that its certification was erroneous when submitted or has become erroneous by reason of changed circumstances.

e. The terms "covered transaction," "debarred," "suspended," "ineligible," "lower tier covered transaction," "participant," "person," "primary covered transaction," "principal," "proposal," and "voluntarily excluded," as used in this clause, have the meanings set out in the Definitions and Coverage sections of rules implementing Executive Order 12549. You may contact the department or agency to which this proposal is submitted for assistance in obtaining a copy of those regulations.

f. The prospective primary participant agrees by submitting this proposal that, should the proposed covered transaction be entered into, it shall not knowingly enter into any lower tier covered transaction with a person who is debarred, suspended, declared ineligible, or voluntarily excluded from participation in this covered transaction, unless authorized by the department or agency entering into this transaction.

g. The prospective primary participant further agrees by submitting this proposal that it will include the clause titled

\*\*\*\*\*

"Certification Regarding Debarment, Suspension, Ineligibility and Voluntary Exclusion-Lower Tier Covered Transaction," provided by the department or agency entering into this covered transaction, without modification in all lower tier covered transactions and in all solicitations for lower tier covered transactions.

h. A participant in a covered transaction may rely upon a certification of a prospective participant in a lower tier covered transaction that is not debarred, suspended, ineligible, or voluntarily excluded from the covered transaction, unless it knows that the certification is erroneous. A participant may decide the method and frequency by which it determines the eligibility of its principals. Each participant may, but is not required to, check the nonprocurement portion of the "Lists of Parties Excluded from Federal Procurement or Nonprocurement Programs" (Nonprocurement List) which is compiled by the General Services Administration.

i. Nothing contained in the foregoing shall be construed to require establishment of a system of records in order to render in good faith the certification required by this clause. The knowledge and information of participant is not required to exceed that which is normally possessed by a prudent person in the ordinary course of business dealings.

j. Except for transactions authorized under paragraph f of these instructions, if a participant in a covered transaction knowingly enters into a lower tier covered transaction with a person who is suspended, debarred, ineligible, or voluntarily excluded from participation in this transaction, in addition to other remedies available to the Federal Government, the department or agency may terminate this transaction for cause or default.

\*\*\*\*\*

### **Certification Regarding Debarment, Suspension, Ineligibility and Voluntary Exclusion-Primary Covered Transactions**

1. The prospective primary participant certifies to the best of its knowledge and belief, that it and its principals:

- a. Are not presently debarred, suspended, proposed for debarment, declared ineligible, or voluntarily excluded from covered transactions by any Federal department or agency;
- b. Have not within a 3-year period preceding this proposal been convicted of or had a civil judgment rendered against them for commission of fraud or a criminal offense in connection with obtaining, attempting to obtain, or performing a public (Federal, State or local) transaction or contract under a public transaction; violation of Federal or State antitrust statutes or commission of embezzlement, theft, forgery, bribery, falsification or destruction of records, making false statements, or receiving stolen property;
- c. Are not presently indicted for or otherwise criminally or civilly charged by a governmental entity (Federal, State or local) with commission of any of the offenses enumerated in paragraph 1b of this certification; and
- d. Have not within a 3-year period preceding this application/proposal had one or more public transactions (Federal, State or local) terminated for cause or default.

2. Where the prospective primary participant is unable to certify to any of the statements in this certification, such prospective participant shall attach an explanation to this proposal.

### **2. Instructions for Certification - Lower Tier Covered Transactions:**

(Applicable to all subcontracts, purchase orders and other lower tier transactions of \$25,000 or more - 49 CFR 29)

- a. By signing and submitting this proposal, the prospective lower tier is providing the certification set out below.
- b. The certification in this clause is a material representation of fact upon which reliance was placed when this transaction was entered into. If it is later determined that the prospective lower tier participant knowingly rendered an erroneous certification, in addition to other remedies available to the Federal Government, the department, or agency with which this transaction originated may pursue available remedies, including suspension and/or debarment.
- c. The prospective lower tier participant shall provide immediate written notice to the person to which this proposal is submitted if at any time the prospective lower tier participant learns that its certification was erroneous by reason of changed circumstances.
- d. The terms "covered transaction," "debarred," "suspended," "ineligible," "primary covered transaction," "participant," "person," "principal," "proposal," and "voluntarily excluded," as used in this clause, have the meanings set out in the Definitions and Coverage sections of rules implementing Executive Order 12549. You may contact the person to which this proposal is submitted for assistance in obtaining a copy of those regulations.
- e. The prospective lower tier participant agrees by submitting this proposal that, should the proposed covered transaction be entered into, it shall not knowingly enter into any lower tier covered transaction with a person who is debarred, suspended, declared ineligible, or voluntarily excluded from participation in this covered transaction, unless authorized by the department or agency with which this transaction originated.
- f. The prospective lower tier participant further agrees by submitting this proposal that it will include this clause titled "Certification Regarding Debarment, Suspension, Ineligibility and Voluntary Exclusion-Lower Tier Covered Transaction," without modification, in all lower tier covered transactions and in all solicitations for lower tier covered transactions.
- g. A participant in a covered transaction may rely upon a certification of a prospective participant in a lower tier covered transaction that is not debarred, suspended, ineligible, or voluntarily excluded from the covered transaction, unless it knows that the certification is erroneous. A participant may decide the method and frequency by which it determines the eligibility of its principals. Each participant may, but is not required to, check the Nonprocurement List.
- h. Nothing contained in the foregoing shall be construed to require establishment of a system of records in order to render in good faith the certification required by this clause. The knowledge and information of participant is not required to exceed that which is normally possessed by a prudent person in the ordinary course of business dealing.
- i. Except for transactions authorized under paragraph e of these instructions, if a participant in a covered transaction knowingly enters into a lower tier covered transaction with a person who is suspended, debarred, ineligible, or voluntarily

excluded from participation in this transaction, in addition to other remedies available to the Federal Government, the department or agency with which this transaction originated may pursue available remedies, including suspension and/or debarment.

\*\*\*\*\*

**Certification Regarding Debarment, Suspension, Ineligibility And Voluntary Exclusion-Lower Tier Covered Transactions:**

1. The prospective lower tier participant certifies, by submission of this proposal, that neither it nor its principals is presently debarred, suspended, proposed for debarment, declared ineligible, or voluntarily excluded from participation in this transaction by any Federal department or agency.

2. Where the prospective lower tier participant is unable to certify to any of the statements in this certification, such prospective participant shall attach an explanation to this proposal.

\*\*\*\*\*

**XII. CERTIFICATION REGARDING USE OF CONTRACT FUNDS FOR LOBBYING**

(Applicable to all Federal-aid construction contracts and to all related subcontracts which exceed \$100,000 - 49 CFR 20)

1. The prospective participant certifies, by signing and submitting this bid or proposal, to the best of his or her knowledge and belief, that:

a. No Federal appropriated funds have been paid or will be paid, by or on behalf of the undersigned, to any person for influencing or attempting to influence an officer or employee of any Federal agency, a Member of Congress, an officer or employee of Congress, or an employee of a Member of Congress in connection with the awarding of any Federal contract, the making of any Federal grant, the making of any Federal loan, the entering into of any cooperative agreement, and the extension, continuation, renewal, amendment, or modification of any Federal contract, grant, loan, or cooperative agreement.

b. If any funds other than Federal appropriated funds have been paid or will be paid to any person for influencing or attempting to influence an officer or employee of any Federal agency, a Member of Congress, an officer or employee of Congress, or an employee of a Member of Congress in connection with this Federal contract, grant, loan, or cooperative agreement, the undersigned shall complete and submit Standard Form-LLL, "Disclosure Form to Report Lobbying," in accordance with its instructions.

2. This certification is a material representation of fact upon which reliance was placed when this transaction was made or entered into. Submission of this certification is a prerequisite for making or entering into this transaction imposed by 31 U.S.C. 1352. Any person who fails to file the required certification shall be subject to a civil penalty of not less than \$10,000 and not more than \$100,000 for each such failure.

3. The prospective participant also agrees by submitting his or her bid or proposal that he or she shall require that the language of this certification be included in all lower tier subcontracts, which exceed \$100,000 and that all such recipients shall certify and disclose accordingly.

## **MINIMUM WAGES FOR FEDERAL AND FEDERALLY ASSISTED CONSTRUCTION CONTRACTS**

This project is funded, in part, with Federal-aid funds and, as such, is subject to the provisions of the Davis-Bacon Act of March 3, 1931, as amended (46 Sta. 1494, as amended, 40 U.S.C. 276a) and of other Federal statutes referred to in a 29 CFR Part 1, Appendix A, as well as such additional statutes as may from time to time be enacted containing provisions for the payment of wages determined to be prevailing by the Secretary of Labor in accordance with the Davis-Bacon Act and pursuant to the provisions of 29 CFR Part 1. The prevailing rates and fringe benefits shown in the General Wage Determination Decisions issued by the U.S. Department of Labor shall, in accordance with the provisions of the foregoing statutes, constitute the minimum wages payable on Federal and federally assisted construction projects to laborers and mechanics of the specified classes engaged on contract work of the character and in the localities described therein.

General Wage Determination Decisions, modifications and supersedes decisions thereto are to be used in accordance with the provisions of 29 CFR Parts 1 and 5. Accordingly, the applicable decision, together with any modifications issued, must be made a part of every contract for performance of the described work within the geographic area indicated as required by an applicable DBRA Federal prevailing wage law and 29 CFR Part 5. The wage rates and fringe benefits contained in the General Wage Determination Decision

### **NOTICE**

The most current **General Wage Determination Decisions** (wage rates) are available on the IDOT web site. They are located on the Letting and Bidding page at <http://www.dot.il.gov/desenv/delett.html>.

In addition, ten (10) days prior to the letting, the applicable Federal wage rates will be e-mailed to subscribers. It is recommended that all contractors subscribe to the Federal Wage Rates List or the Contractor's Packet through IDOT's subscription service.

PLEASE NOTE: if you have already subscribed to the Contractor's Packet you will automatically receive the Federal Wage Rates.

The instructions for subscribing are at <http://www.dot.il.gov/desenv/subsc.html>.

If you have any questions concerning the wage rates, please contact IDOT's Chief Contract Official at 217-782-7806.