

teasleyck
 3/31/2005
 c:\projects\94905d\04201pa.dgn
EXJNT-69

FAI RTE.	SECTION	COUNTY	TOTAL SHEETS	SHEET NO.
64	(41-7)RS-1	JEFFERSON	48	31
FED. ROAD DIST. NO. 7		ILLINOIS	FED. AID PROJECT NO.	

CONTRACT NO. 94905

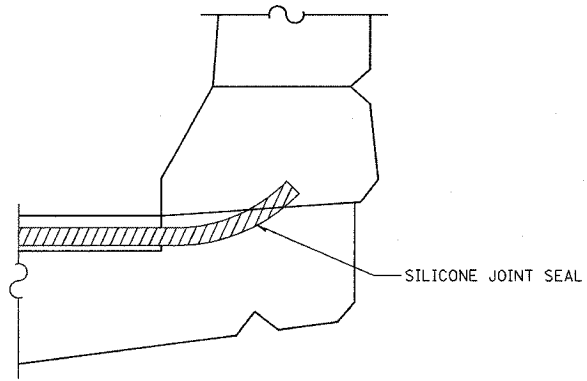

TYPICAL END OF SEAL TREATMENT
 WHEN REPLACING NEOPRENE JOINT

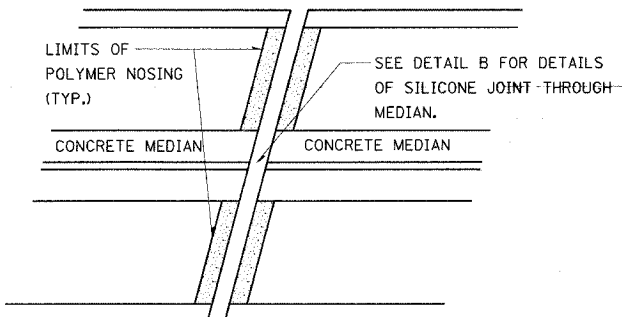

JOINT TREATMENT FOR
 PROPOSED CONCRETE MEDIAN
 EXPANSION JOINTS

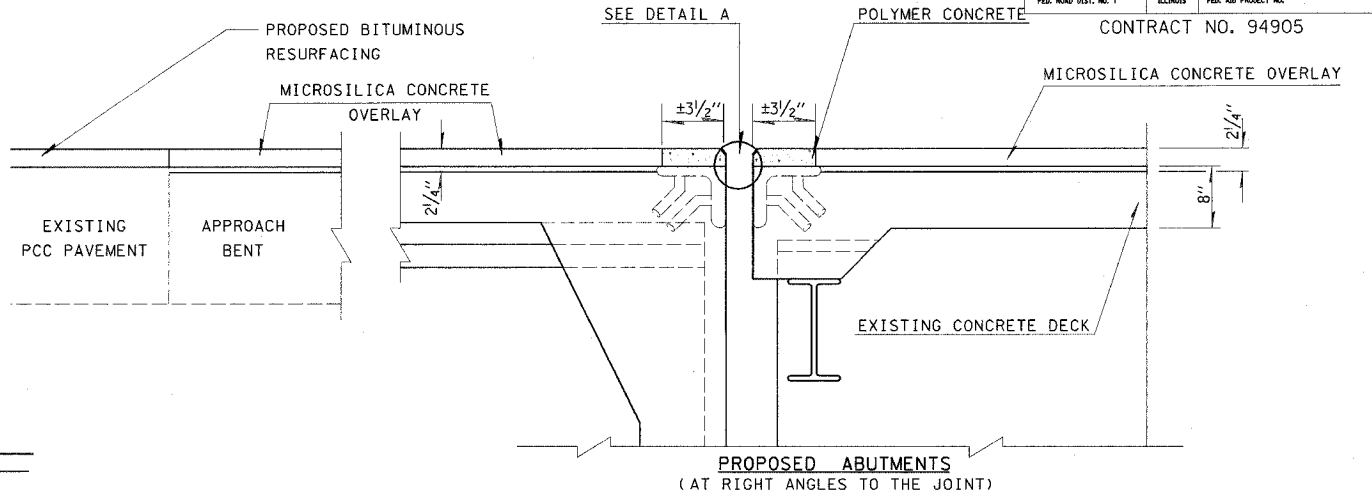

NOTE: SURFACE OF EXISTING ANGLE
 IRON EXPANSION DAMS TO BE
 CLEANED TO THE SATISFACTION
 OF THE ENGINEER PRIOR TO
 PLACEMENT OF POLYMER CONCRETE.
 COST INCLUDED IN POLYMER CONCRETE.

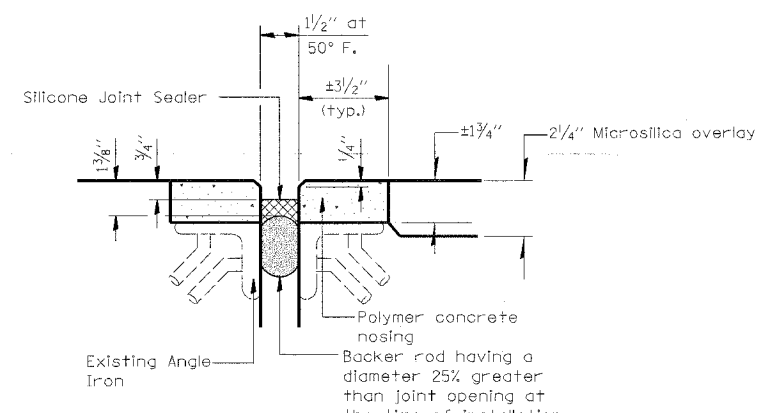

SILICONE JOINT SEALER DETAIL
 DETAIL A

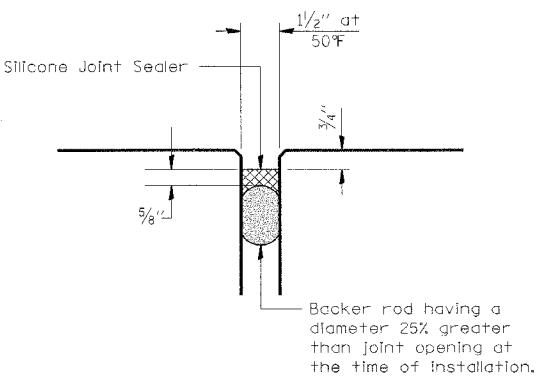

SILICONE JOINT SEALER DETAIL
 DETAIL B

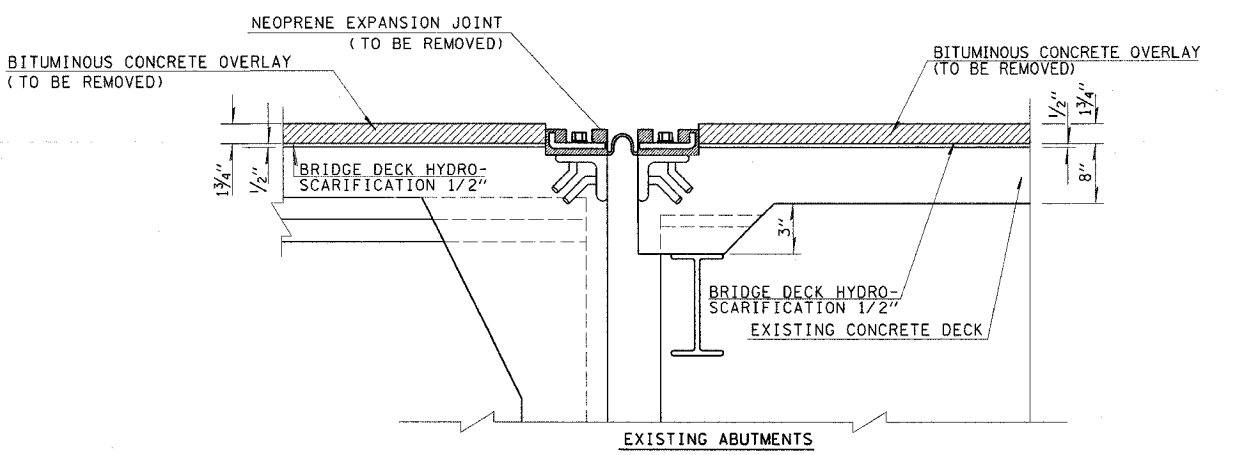

BITUMINOUS CONCRETE REMOVAL (DECK)
 REMOVE EXISTING NEOPRENE EXPANSION JOINTS
 (COST INCLUDED IN SILICONE JOINT SEALER)

REVISIONS	
NAME	DATE

ILLINOIS DEPARTMENT OF TRANSPORTATION
**EXPANSION JOINT DETAILS
 BOTH ABUTMENTS
 S.N. 041-0069**
 SCALE: VERT. DRAWN BY
 HORIZ. CHECKED BY
 DATE