

STATE OF ILLINOIS
DEPARTMENT OF TRANSPORTATION

F.A.P. RTE.	SECTION	COUNTY	TOTAL SHEETS	SHEET NO.
322	11-1	CHRISTIAN	310	101
STA.		TO STA.		
FED. ROAD DIST. NO.		ILLINOIS FED. AID PROJECT		

SW 14 SEC 13, T13 N, R1 E, 3RD PM

PARCEL NO 6085175
ERMA JEAN POSTLEWAIT
SEE TABULATIONS ON SHEET 12

PARCEL NO 6085176
STATE BANK OF BLUE MOUND
WILLIAM PHELPS TRUST
SEE TABULATIONS ON SHEET 13

PARCEL NO 6085174
ROBERT L. YOUNKER
MARILYN J. YOUNKER
SEE TABULATIONS ON SHEET 12

FOUND A SPIKE
OVER A STONE
SW CORNER
SEC 13

FOUND
GAS PIPE
NE CORNER
NW 1/4
SEC 24

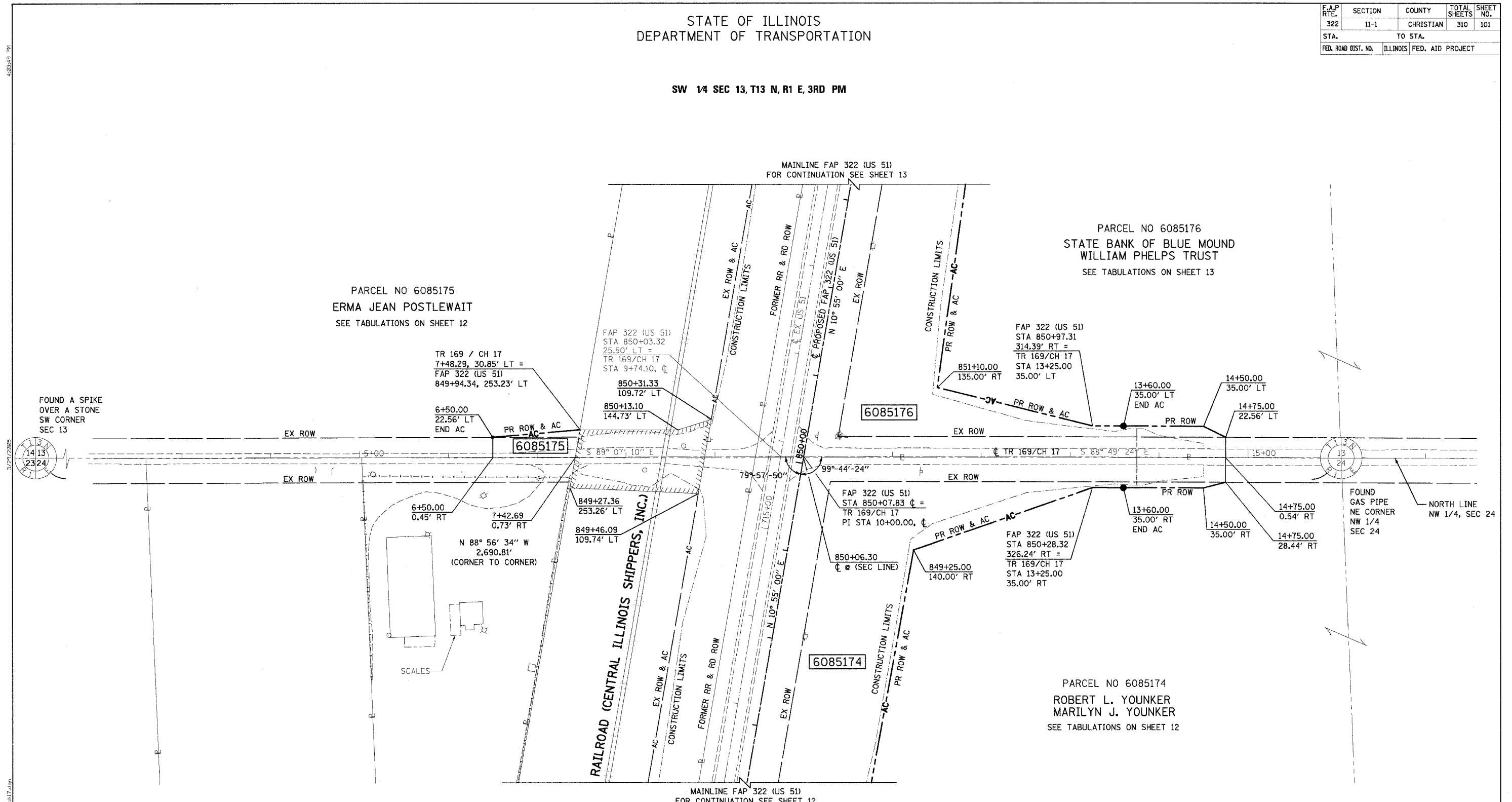

NW 14 SEC 24, T13 N, R1 E, 3RD PM

NOTES:
BEARINGS ARE BASED ON THE ILLINOIS STATE PLANE
COORDINATE SYSTEM, NAD83 1986 - WEST ZONE
SURVEYED IN ENGLISH.

PLAT DISTANCES AND STATIONING ARE IN GRID ENGLISH.
TO CONVERT TO GROUND DIVIDE BY GRID FACTOR.
GRID FACTOR = 1.00003150

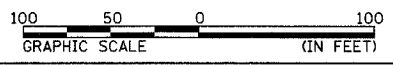

RIGHT OF WAY PLANS	
ROUTE	F.A.P. 322 (US 51)
SECTION	11-1
PROJECT	
COUNTY	CHRISTIAN
JOB NO.	R-96-008-95
STA	2+00 TO STA 17+00
SCALE	1 = 50'
SHEET NO. 23 OF 24	

STATE OF ILLINOIS
DEPARTMENT OF TRANSPORTATION

F.A.P. RTE.	SECTION	COUNTY	TOTAL SHEETS	SHEET NO.
322	11-1	CHRISTIAN	310	102
STA.		TO STA.		
FED. ROAD DIST. NO.		ILLINOIS FED. AID PROJECT		

SW 1/4 SEC 12, T13 N, R1 E, 3RD PM

SE 1/4 SEC 12, T13 N, R1 E, 3RD PM

MAINLINE FAP 322 (US 51)
FOR CONTINUATION SEE SHEET 16

PARCEL NO 6085180
WAYNE ELLISON
LOIS ELLISON
SEE TABULATIONS ON SHEET 16

PARCEL NO 6085181 B
HUNTER FARMS, INC.
SEE TABULATIONS ON SHEET 17

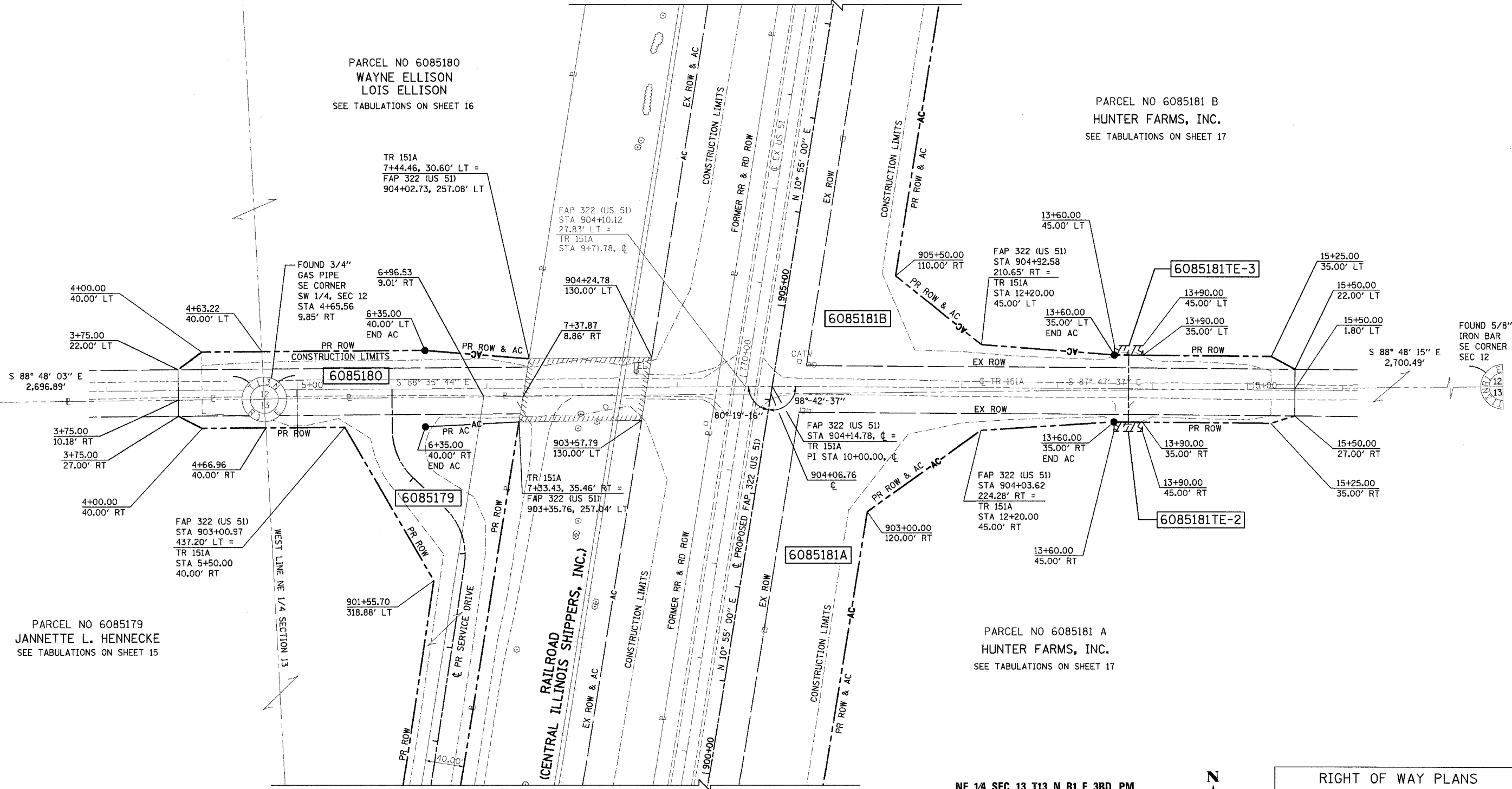

PARCEL NO 6085179
JANNETTE L. HENNECKE
SEE TABULATIONS ON SHEET 15

PARCEL NO 6085181 A
HUNTER FARMS, INC.
SEE TABULATIONS ON SHEET 17

NW 1/4 SEC 13, T13 N, R1 E, 3RD PM

NE 1/4 SEC 13, T13 N, R1 E, 3RD PM

MAINLINE FAP 322 (US 51)
FOR CONTINUATION SEE SHEET 15 & 16

NOTES:
BEARINGS ARE BASED ON THE ILLINOIS STATE PLANE
COORDINATE SYSTEM, NAD83 1986 - WEST ZONE
SURVEYED IN ENGLISH.

PLAT DISTANCES AND STATIONING ARE IN GRID ENGLISH.
TO CONVERT TO GROUND DIVIDE BY GRID FACTOR.
GRID FACTOR = 1.00003150

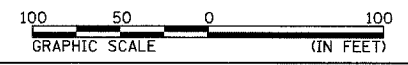

RIGHT OF WAY PLANS	
ROUTE	F.A.P. 322 (US 51)
SECTION	11-1
PROJECT	
COUNTY	CHRISTIAN
JOB NO.	R-96-008-95
STA	3+00 TO STA 18+00
SCALE	1 = 50'
SHEET NO. 24 OF 24	

F.A.P. RTE.	SECTION	COUNTY	TOTAL SHEETS	SHEET NO.
322	11-10	CHRISTIAN	310	103
STA.		TO STA.		
FED. ROAD DIST. NO.	ILLINOIS	FED. AID PROJECT		

POINT	FAP 322 (US 51)		ELEVATION
	STATION	OFFSET	
A1	713+65.00	13.00' RT	637.57
A2	713+99.01	5.41' RT	637.21
A3	714+00.01	8.51' LT	637.27
A4	713+45.00	25.00' LT	637.90
A5	715+25.00	13.00' LT	636.61
A6	714+90.99	5.41' LT	636.66
A7	714+89.99	8.51' RT	636.73
A8	715+45.00	25.00' RT	636.73

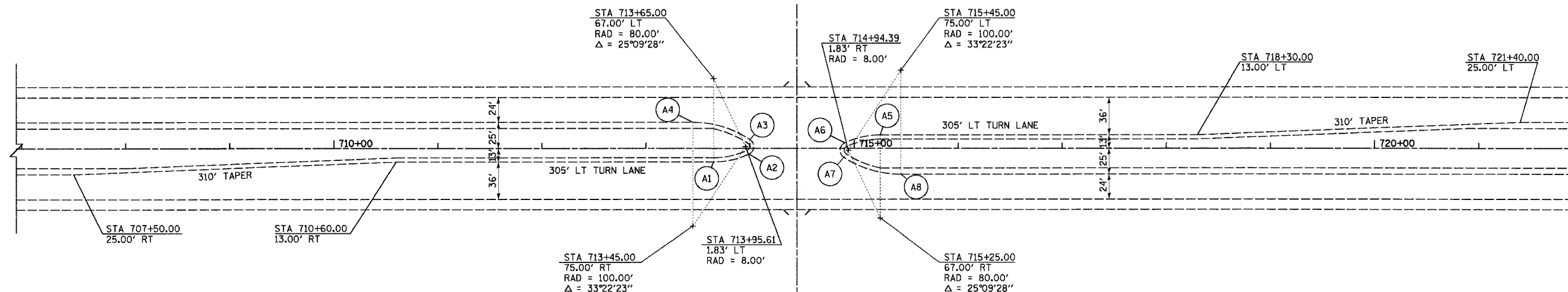

3/20/2005

\\s01.fina\012223\new\plans\11-10\geomd714.dgn

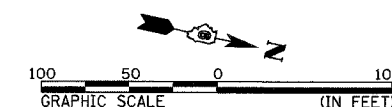

NOTES:
 ALL STATIONS, OFFSETS, AND ELEVATIONS SHOWN ARE FOR FINAL PAVING.
 SEE SHEET 52 FOR PLAN AND PROFILES.

REVISIONS	
NAME	DATE

ILLINOIS DEPARTMENT OF TRANSPORTATION
 GEOMETRIC DETAILS
 MEDIAN CROSSOVER - STA 714+45
 FAP 322 (US 51)
 SECTION 11-1
 CHRISTIAN COUNTY
 SCALE: 1"=50'
 DATE 3/18/05
 DRAWN BY BDJ
 CHECKED BY SEB

POINT	FAP 322 (US 51)		TR 193		ELEVATION
	STATION	OFFSET	STATION	OFFSET	
A1	741+01.59	49.00' LT	19+71.73	96.43' RT	627.70
A2	741+15.67	49.57' LT	19+68.04	82.83' RT	627.64
A3	741+29.66	51.27' LT	19+63.28	69.57' RT	627.57
A4	741+43.47	54.08' LT	19+57.46	56.73' RT	627.47
A5	741+57.00	58.00' LT	19+50.63	44.41' RT	627.31
A6	741+70.18	63.00' LT	19+42.83	32.67' RT	627.10
A7	741+78.46	67.50' LT	19+36.61	25.59' RT	626.94
A8	741+85.75	73.47' LT	19+29.17	19.81' RT	626.78
A9	741+91.80	80.70' LT	19+20.77	15.52' RT	626.61
A10	741+96.38	88.94' LT	19+11.72	12.89' RT	626.45
A11	741+99.33	97.89' LT	19+02.34	12.00' RT	626.28

POINT	FAP 322 (US 51)		TR 193		ELEVATION
	STATION	OFFSET	STATION	OFFSET	
E1	740+69.66	25.00' LT	20+02.22	122.23' RT	627.79
E2	741+34.18	1.40' LT	20+10.89	54.08' RT	627.15
E3	741+29.73	12.68' RT	20+25.60	55.28' RT	627.35
E4	741+22.54	13.00' RT	20+27.52	62.22' RT	627.39
E5	742+56.10	13.00' LT	19+72.48	62.22' LT	626.99
E6	742+48.91	12.68' LT	19+74.40	55.28' LT	627.00
E7	742+44.47	1.40' RT	19+89.11	54.08' LT	626.82
E8	743+08.98	25.00' RT	19+97.78	122.23' RT	627.07
E9	741+95.02	25.00' LT	19+74.36	CL	627.42
E10	741+83.62	25.00' RT	20+25.64	CL	627.45

POINT	FAP 322 (US 51)		TR 193		ELEVATION
	STATION	OFFSET	STATION	OFFSET	
D1	740+68.29	61.00' RT	20+86.38	104.45' RT	627.56
D2	740+87.69	63.96' RT	20+84.95	84.87' RT	627.44
D3	741+05.32	72.58' RT	20+89.44	65.77' RT	627.21
D4	741+19.58	86.07' RT	20+99.42	48.87' RT	626.83
D5	741+29.16	103.20' RT	21+13.99	35.72' RT	626.38
D6	741+33.19	122.40' RT	21+31.82	27.52' RT	625.89
D7	741+33.80	144.75' RT	21+53.47	21.96' RT	625.40
D8	741+33.17	167.10' RT	21+75.40	17.61' RT	624.98
D9	741+31.28	189.38' RT	21+97.54	14.50' RT	624.63
D10	741+28.15	211.51' RT	22+19.82	12.63' RT	624.27
D11	741+23.80	233.44' RT	22+42.17	12.00' RT	623.90

POINT	FAP 322 (US 51)		TR 193		ELEVATION
	STATION	OFFSET	STATION	OFFSET	
B1	742+54.85	233.44' LT	17+57.83	12.00' LT	623.45
B2	742+50.49	211.51' LT	17+80.18	12.63' LT	623.87
B3	742+47.36	189.38' LT	18+02.46	14.50' LT	624.28
B4	742+45.48	167.10' LT	18+24.60	17.61' LT	624.70
B5	742+44.84	144.75' LT	18+46.53	21.96' LT	625.14
B6	742+45.45	122.40' LT	18+68.18	27.52' LT	625.64
B7	742+49.49	103.20' LT	18+86.01	35.72' LT	626.08
B8	742+59.07	86.07' LT	19+00.58	48.87' LT	626.43
B9	742+73.32	72.58' LT	19+10.56	65.77' LT	626.71
B10	742+90.95	63.96' LT	19+15.05	84.87' LT	626.83
B11	743+10.36	61.00' LT	19+13.62	104.45' LT	626.83

F.A.P. RTE.	SECTION	COUNTY	TOTAL SHEETS	SHEET NO.
322	11-10	CHRISTIAN	310	104

STA. TO STA.
FED. ROAD DIST. NO. ILLINOIS FED. AID PROJECT

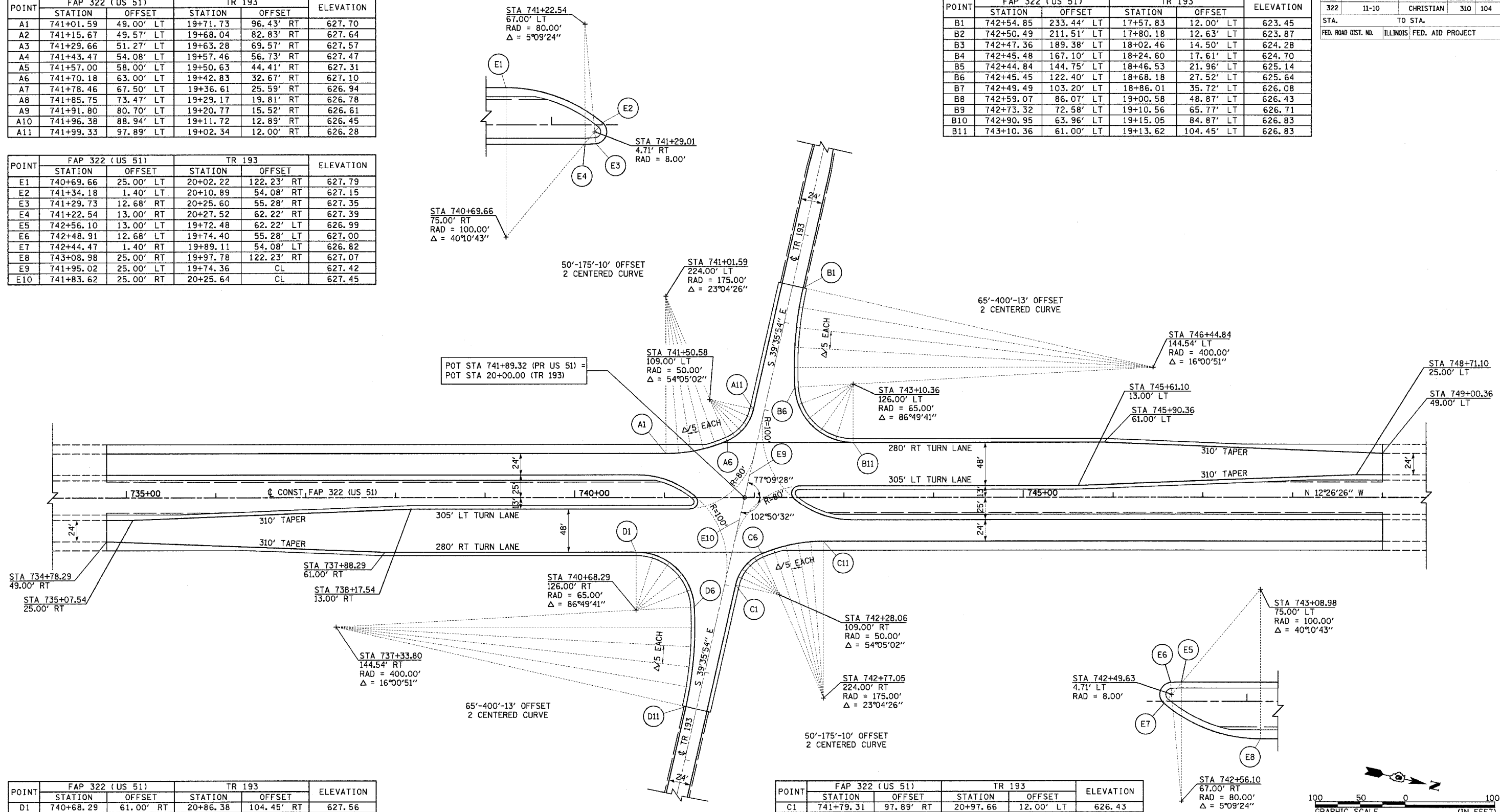

NOTES:
ALL STATIONS, OFFSETS, AND ELEVATIONS SHOWN ARE FOR FINAL PAVING.
SEE SHEETS 54 AND 72 FOR PLAN AND PROFILES.

POINT	FAP 322 (US 51)		TR 193		ELEVATION
	STATION	OFFSET	STATION	OFFSET	
C1	741+79.31	97.89' RT	20+97.66	12.00' LT	626.43
C2	741+82.27	88.94' RT	20+88.28	12.89' LT	626.58
C3	741+86.85	80.70' RT	20+79.23	15.52' LT	626.73
C4	741+92.89	73.47' RT	20+70.83	19.81' LT	626.86
C5	742+00.18	67.50' RT	20+63.39	25.59' LT	626.97
C6	742+08.47	63.00' RT	20+57.17	32.67' LT	627.06
C7	742+21.64	58.00' RT	20+49.37	44.41' LT	627.15
C8	742+35.18	54.08' RT	20+42.54	56.73' LT	627.19
C9	742+48.99	51.27' RT	20+36.72	69.57' LT	627.21
C10	742+62.97	49.57' RT	20+31.96	82.83' LT	627.20
C11	742+77.05	49.00' RT	20+28.28	96.43' LT	627.17

REVISIONS	
NAME	DATE

ILLINOIS DEPARTMENT OF TRANSPORTATION
GEOMETRIC DETAILS
TR 193
FAP 322 (US 51)
SECTION 11-1
CHRISTIAN COUNTY

SCALE: 1"=50'
DATE 3/18/05

DRAWN BY BGJ
CHECKED BY SEB

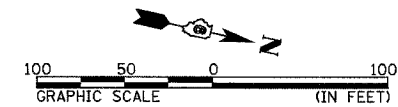

3/29/2005
en:\f\leva\0223\0223\pave\fig\plan\11-1\geom\92677.dwg

F.A.P. RTE.	SECTION	COUNTY	TOTAL SHEETS	SHEET NO.
322	11-10	CHRISTIAN	310	105
STA.		TO STA.		
FED. ROAD DIST. NO.	ILLINOIS	FED. AID PROJECT		

SB TRANSITION CURVE #1 DATA:
 PI STA = 101+54.01
 = 771+85.44 22.24' LT FAP 322
 $\Delta = 2^\circ 12' 21''$ (LT)
 $D = 0^\circ 42' 58''$
 $R = 8,000.00'$
 $T = 154.01'$
 $L = 307.98'$
 $E = 1.48'$
 $SE = RC$
 PC STA = 100+00.00
 = 770+32.26 24.81' LT FAP 322
 PRC STA = 103+07.98
 = 773+39.34 28.16' LT FAP 322

SB TRANSITION CURVE #2 DATA:
 PI STA = 105+38.40
 = 775+69.58 37.00' LT FAP 322
 $\Delta = 2^\circ 12' 00''$ (RT)
 $D = 0^\circ 28' 39''$
 $R = 12,000.00'$
 $T = 230.42'$
 $L = 460.78'$
 $E = 2.21'$
 $SE = NC$
 PRC STA = 103+07.98
 = 773+39.34 28.16' LT FAP 322
 PT STA = 107+68.76
 = 778+00.00 37.00' LT FAP 322

POINT	FAP 322 (US 51)		CROSSOVER "A"		ELEVATION
	STATION	OFFSET	STATION	OFFSET	
A1	776+04.59	9.20' LT	206+32.50	12.00' LT	621.88
A2	776+12.07	8.62' LT	206+40.00	12.00' LT	621.86
A3	776+32.01	7.09' LT	206+60.00	12.00' LT	621.74
A4	776+51.95	5.55' LT	206+80.00	12.00' LT	621.56
A5	776+71.89	4.02' LT	207+00.00	12.00' LT	621.36
A6	776+91.83	2.48' LT	207+20.00	12.00' LT	621.19
A7	777+11.77	0.94' LT	207+40.00	12.00' LT	621.12

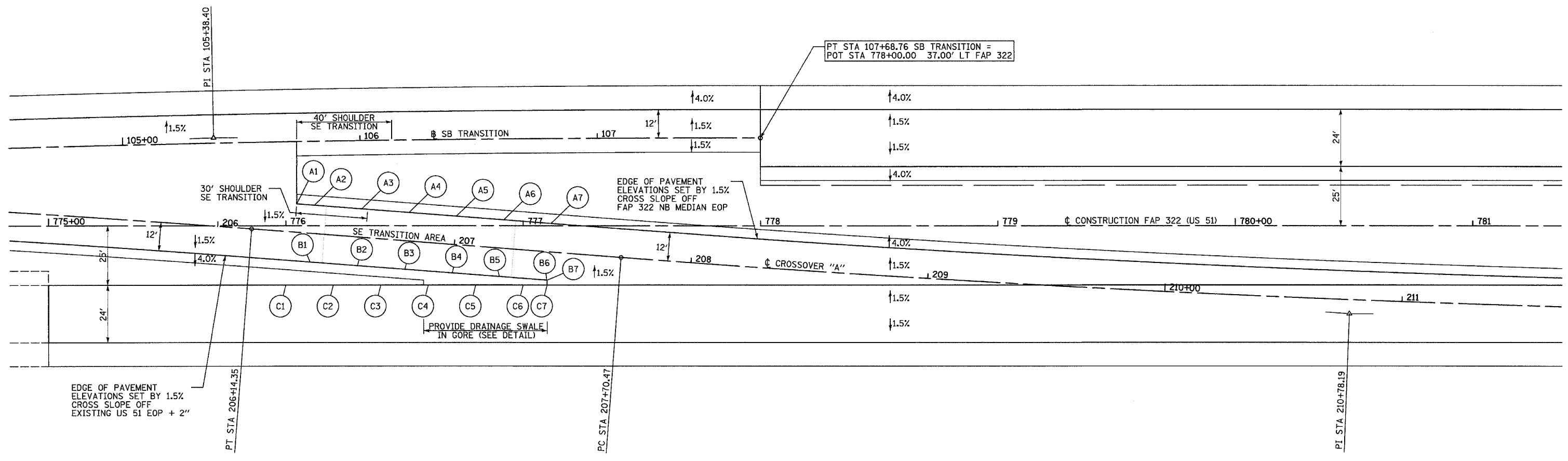

POINT	FAP 322 (US 51)		CROSSOVER "A"		ELEVATION
	STATION	OFFSET	STATION	OFFSET	
B1	776+10.22	15.31' RT	206+40.00	12.00' RT	621.50
B2	776+30.17	16.84' RT	206+60.00	12.00' RT	621.52
B3	776+50.11	18.38' RT	206+80.00	12.00' RT	621.51
B4	776+70.05	19.91' RT	207+00.00	12.00' RT	621.49
B5	776+89.99	21.45' RT	207+20.00	12.00' RT	621.50
B6	777+09.93	22.99' RT	207+40.00	12.00' RT	621.48
B7	777+10.11	23.00' RT	207+40.18	12.00' RT	621.48

POINT	FAP 322 (US 51)		ELEVATION
	STATION	OFFSET	
C1	776+00.00	25.00' RT	621.20
C2	776+20.00	25.00' RT	621.23
C3	776+40.00	25.00' RT	621.27
C4	776+60.00	25.00' RT	621.31
C5	776+80.00	25.00' RT	621.34
C6	777+00.00	25.00' RT	621.38
C7	777+10.11	25.00' RT	621.40

CROSSOVER "A" CURVE #1 DATA:
 PI STA = 203+07.33
 = 772+79.16 22.23' LT FAP 322
 $\Delta = 4^\circ 23' 60''$ (RT)
 $D = 0^\circ 42' 58''$
 $R = 8,000.00'$
 $T = 307.33'$
 $L = 614.35'$
 $E = 5.90'$
 $SE = NC$
 PC STA = 200+00.00
 = 769+73.06 27.27' LT FAP 322
 PT STA = 206+14.35
 = 775+85.58 1.37' RT FAP 322

CROSSOVER "A" SE DATA:
 TRANSITION SE:
 STA 206+45 (-1.5%) TO STA 207+25 (+1.5%)

CROSSOVER "A" CURVE #2 DATA:
 PI STA = 210+78.19
 = 780+48.04 37.00' RT FAP 322
 $\Delta = 4^\circ 24' 20''$ (LT)
 $D = 0^\circ 42' 58''$
 $R = 8,000.00'$
 $T = 307.72'$
 $L = 615.13'$
 $E = 5.92'$
 $SE = NC$
 PC STA = 207+70.47
 = 777+41.24 13.36' RT FAP 322
 PT STA = 213+85.60
 = 783+55.76 37.00' RT FAP 322

NOTES:
 ALL STATIONS, OFFSETS, AND ELEVATIONS SHOWN ARE FOR FINAL PAVING.
 SEE SHEET 71 FOR PLAN AND PROFILES.

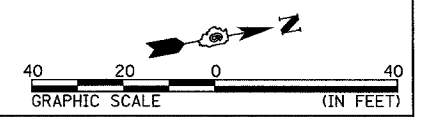

REVISIONS	
NAME	DATE

ILLINOIS DEPARTMENT OF TRANSPORTATION
GEOMETRIC DETAILS
CROSSOVER "A"
 FAP 322 (US 51)
 SECTION 11-1
 CHRISTIAN COUNTY
 SCALE: 1"=20'
 DATE: 3/21/05
 DRAWN BY: SEB
 CHECKED BY: EBB

POINT	FAP 322 (US 51)		TR 185		ELEVATION
	STATION	OFFSET	STATION	OFFSET	
A1	794+80.30	49.00' LT	9+28.93	120.68' RT	623.48
A2	794+94.38	49.57' LT	9+30.82	106.72' RT	623.48
A3	795+08.37	51.27' LT	9+31.58	92.65' RT	623.46
A4	795+22.17	54.08' LT	9+31.20	78.56' RT	623.42
A5	795+35.71	58.00' LT	9+29.70	64.55' RT	623.36
A6	795+48.88	63.00' LT	9+27.07	50.70' RT	623.27
A7	795+60.39	69.85' LT	9+22.33	38.18' RT	623.14
A8	795+69.66	79.51' LT	9+14.43	27.37' RT	623.06
A9	795+76.04	91.28' LT	9+03.95	19.04' RT	623.23
A10	795+79.07	104.32' LT	8+91.63	13.79' RT	623.57
A11	795+78.53	117.70' LT	8+78.36	12.00' RT	623.96

POINT	FAP 322 (US 51)		TR 185		ELEVATION
	STATION	OFFSET	STATION	OFFSET	
E1	795+23.20	25.00' LT	9+60.02	82.61' RT	623.52
E2	795+64.23	16.19' LT	9+75.83	43.73' RT	623.39
E3	795+65.67	2.44' LT	9+89.62	44.70' RT	623.11
E4	795+18.43	13.00' RT	9+96.61	93.92' RT	623.28
E5	797+04.57	13.00' LT	10+03.39	93.92' LT	623.47
E6	796+57.32	2.44' RT	10+10.38	44.70' LT	623.21
E7	796+58.77	16.19' RT	10+24.17	43.73' LT	623.48
E8	796+99.80	25.00' RT	10+39.98	82.61' LT	623.70
E9	796+07.08	25.00' LT	9+74.61	CL	623.61
E10	796+15.92	25.00' RT	10+25.39	CL	623.62

POINT	FAP 322 (US 51)		TR 185		ELEVATION
	STATION	OFFSET	STATION	OFFSET	
D1	795+42.36	61.00' RT	10+48.05	78.69' RT	623.30
D2	795+56.76	62.61' RT	10+52.14	64.80' RT	623.28
D3	795+70.43	67.38' RT	10+59.21	52.16' RT	623.20
D4	795+82.72	75.05' RT	10+68.90	41.39' RT	623.06
D5	795+93.00	85.25' RT	10+80.73	33.04' RT	622.87
D6	796+00.77	97.48' RT	10+94.12	27.52' RT	622.65
D7	796+10.01	117.83' RT	11+15.78	21.96' RT	622.37
D8	796+18.11	138.67' RT	11+37.71	17.61' RT	622.17
D9	796+25.03	159.93' RT	11+59.85	14.50' RT	622.07
D10	796+30.74	181.54' RT	11+82.12	12.63' RT	622.04
D11	796+35.25	203.44' RT	12+04.47	12.00' RT	622.08

POINT	FAP 322 (US 51)		TR 185		ELEVATION
	STATION	OFFSET	STATION	OFFSET	
B1	795+87.94	206.88' LT	7+91.99	12.00' LT	623.37
B2	795+92.23	184.38' LT	8+14.88	12.66' LT	624.15
B3	795+97.80	162.17' LT	8+37.70	14.62' LT	624.43
B4	796+04.64	140.31' LT	8+60.63	17.65' LT	624.24
B5	796+12.71	118.88' LT	8+83.14	21.87' LT	623.69
B6	796+22.00	97.95' LT	9+05.37	27.38' LT	623.02
B7	796+29.73	85.58' LT	9+18.90	32.84' LT	622.94
B8	796+40.03	75.24' LT	9+30.87	41.19' LT	623.12
B9	796+52.37	67.47' LT	9+40.67	51.99' LT	623.28
B10	796+66.14	62.64' LT	9+47.82	64.70' LT	623.39
B11	796+80.64	61.00' LT	9+51.96	78.69' LT	623.44

POINT	FAP 322 (US 51)		TR 185		ELEVATION
	STATION	OFFSET	STATION	OFFSET	
C1	796+44.47	117.70' RT	11+21.64	12.00' LT	622.43
C2	796+43.93	104.32' RT	11+08.37	13.79' LT	622.57
C3	796+46.96	91.28' RT	10+96.05	19.04' LT	622.71
C4	796+53.34	79.51' RT	10+85.57	27.37' LT	622.89
C5	796+62.61	69.85' RT	10+77.68	38.18' LT	623.15
C6	796+74.12	63.00' RT	10+72.93	50.70' LT	623.35
C7	796+87.29	58.00' RT	10+70.30	64.55' LT	623.49
C8	797+00.83	54.08' RT	10+68.80	78.56' LT	623.60
C9	797+14.63	51.27' RT	10+68.42	92.65' LT	623.67
C10	797+28.62	49.57' RT	10+69.18	106.72' LT	623.72
C11	797+42.70	49.00' RT	10+71.07	120.68' LT	623.74

F.A.P. RTE.	SECTION	COUNTY	TOTAL SHEETS	SHEET NO.
322	11-10	CHRISTIAN	310	106

STA. TO STA.
FED. ROAD DIST. NO. ILLINOIS FED. AID PROJECT

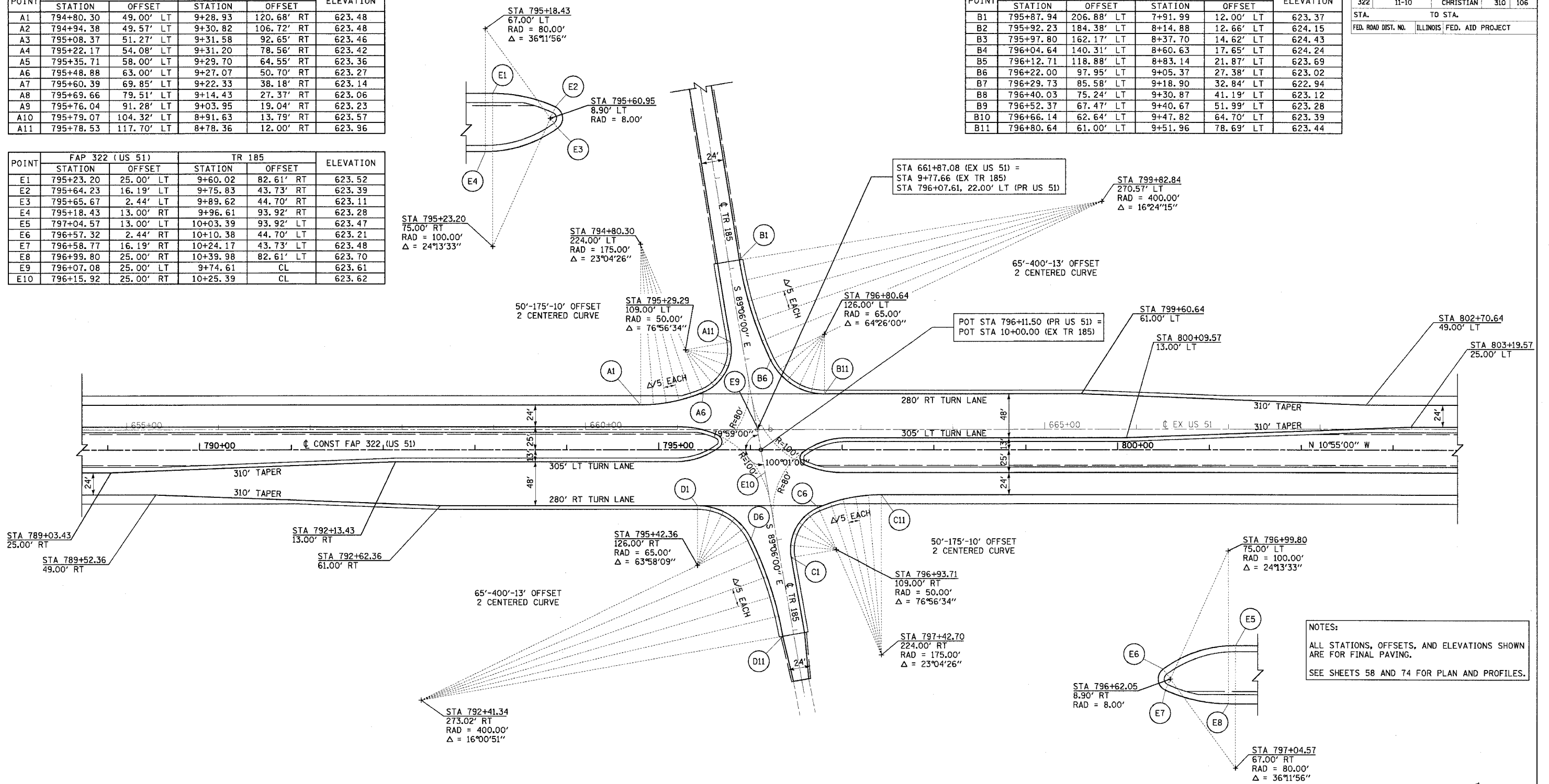

NOTES:
ALL STATIONS, OFFSETS, AND ELEVATIONS SHOWN ARE FOR FINAL PAVING.
SEE SHEETS 58 AND 74 FOR PLAN AND PROFILES.

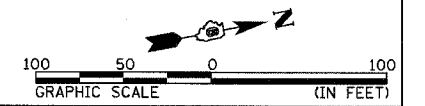

ILLINOIS DEPARTMENT OF TRANSPORTATION
GEOMETRIC DETAILS
TR 185
FAP 322 (US 51)
SECTION 11-1
CHRISTIAN COUNTY

SCALE: 1"=50'
DATE 3/18/05

DRAWN BY BGJ
CHECKED BY SEB

REVISIONS	
NAME	DATE

3/20/2005

POINT	FAP 322 (US 51)		TR 169 / CH 17		ELEVATION
	STATION	OFFSET	STATION	OFFSET	
A1	848+76.59	49.00' LT	9+28.88	120.70' RT	629.57
A2	848+90.67	49.57' LT	9+30.77	106.73' RT	629.56
A3	849+04.66	51.27' LT	9+31.54	92.66' RT	629.54
A4	849+18.46	54.08' LT	9+31.17	78.58' RT	629.49
A5	849+32.00	58.00' LT	9+29.67	64.57' RT	629.41
A6	849+45.17	63.00' LT	9+27.05	50.72' RT	629.31
A7	849+56.68	69.85' LT	9+22.30	38.20' RT	629.18
A8	849+65.96	79.51' LT	9+14.41	27.38' RT	629.07
A9	849+72.33	91.29' LT	9+03.92	19.05' RT	629.03
A10	849+75.36	104.33' LT	8+91.61	13.79' RT	629.13
A11	849+74.81	117.71' LT	8+78.33	12.00' RT	629.40

POINT	FAP 322 (US 51)		TR 169 / CH 17		ELEVATION
	STATION	OFFSET	STATION	OFFSET	
E1	849+19.24	25.00' LT	9+59.94	82.88' RT	629.59
E2	849+60.45	16.12' LT	9+75.88	43.85' RT	629.42
E3	849+61.87	2.36' LT	9+89.66	44.85' RT	629.14
E4	849+14.73	13.00' RT	9+96.58	93.94' RT	629.36
E5	851+00.50	13.00' LT	10+02.87	93.53' LT	629.34
E6	850+53.42	2.32' RT	10+10.00	44.54' LT	629.14
E7	850+54.82	16.08' RT	10+23.80	43.59' LT	629.42
E8	850+96.11	25.00' RT	10+39.57	82.78' LT	629.58
E9	850+03.41	25.00' LT	9+74.61	CL	629.60
E10	850+12.12	25.00' RT	10+25.37	CL	629.60

POINT	FAP 322 (US 51)		TR 169 / CH 17		ELEVATION
	STATION	OFFSET	STATION	OFFSET	
D1	849+38.14	61.00' RT	10+48.33	79.00' RT	629.35
D2	849+52.60	62.63' RT	10+52.38	65.03' RT	629.32
D3	849+66.33	67.43' RT	10+59.44	52.31' RT	629.23
D4	849+78.65	75.16' RT	10+69.14	41.48' RT	629.08
D5	849+88.94	85.45' RT	10+81.02	33.08' RT	628.90
D6	849+96.69	97.76' RT	10+94.46	27.52' RT	628.71
D7	850+05.83	118.16' RT	11+16.12	21.96' RT	628.42
D8	850+13.83	139.04' RT	11+38.05	17.61' RT	628.14
D9	850+20.64	160.33' RT	11+60.19	14.50' RT	627.85
D10	850+26.26	181.97' RT	11+82.46	12.63' RT	627.58
D11	850+30.65	203.89' RT	12+04.81	12.00' RT	627.30

POINT	FAP 322 (US 51)		TR 169 / CH 17		ELEVATION
	STATION	OFFSET	STATION	OFFSET	
B1	849+84.02	203.41' LT	7+95.55	12.00' LT	630.08
B2	849+88.53	181.51' LT	8+17.90	12.63' LT	629.86
B3	849+94.25	159.90' LT	8+40.18	14.50' LT	629.76
B4	850+01.18	138.64' LT	8+62.32	17.61' LT	629.58
B5	850+09.28	117.81' LT	8+84.25	21.96' LT	629.13
B6	850+18.53	97.46' LT	9+05.90	27.52' LT	628.88
B7	850+26.30	85.24' LT	9+19.29	33.04' LT	628.90
B8	850+36.58	75.04' LT	9+31.12	41.39' LT	629.08
B9	850+48.87	67.37' LT	9+40.81	52.15' LT	629.23
B10	850+62.54	62.61' LT	9+47.88	64.78' LT	629.32
B11	850+76.93	61.00' LT	9+51.98	78.67' LT	629.35

POINT	FAP 322 (US 51)		TR 169 / CH 17		ELEVATION
	STATION	OFFSET	STATION	OFFSET	
C1	850+40.17	117.46' RT	11+21.24	12.00' LT	628.40
C2	850+39.69	104.13' RT	11+08.02	13.78' LT	628.57
C3	850+42.75	91.14' RT	10+95.74	18.99' LT	628.78
C4	850+49.13	79.43' RT	10+85.27	27.27' LT	628.99
C5	850+58.39	69.82' RT	10+77.37	38.01' LT	629.18
C6	850+69.85	63.00' RT	10+72.58	50.47' LT	629.31
C7	850+83.03	58.00' RT	10+69.89	64.30' LT	629.41
C8	850+96.56	54.08' RT	10+68.32	78.30' LT	629.48
C9	851+10.37	51.27' RT	10+67.87	92.39' LT	629.53
C10	851+24.36	49.57' RT	10+68.57	106.46' LT	629.56
C11	851+38.44	49.00' RT	10+70.39	120.43' LT	629.56

F.A.P. RTE.	SECTION	COUNTY	TOTAL SHEETS	SHEET NO.
322	11-10	CHRISTIAN	310	107
STA.		TO STA.		
FED. ROAD DIST. NO.		ILLINOIS FED. AID PROJECT		

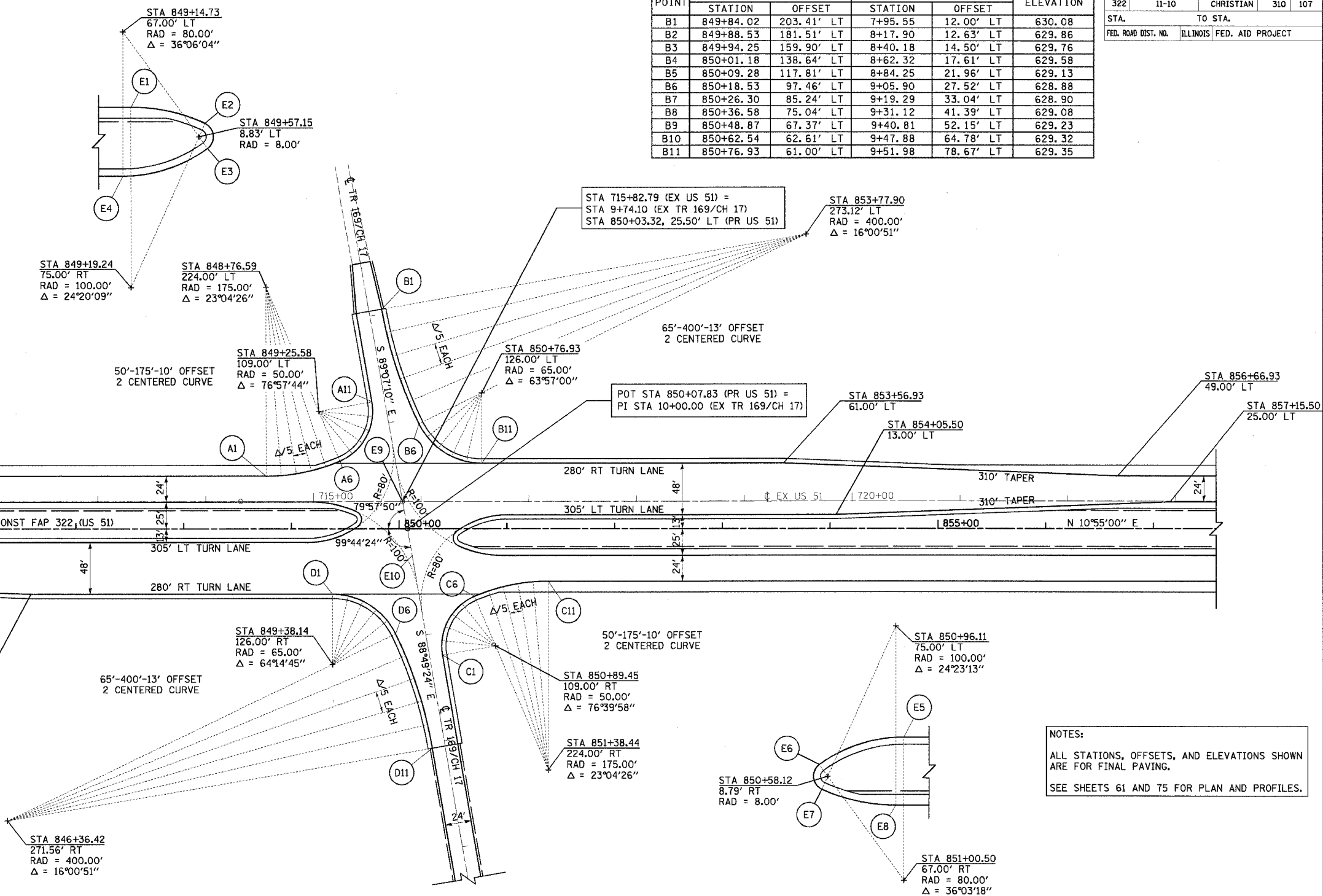

NOTES:
 ALL STATIONS, OFFSETS, AND ELEVATIONS SHOWN ARE FOR FINAL PAVING.
 SEE SHEETS 61 AND 75 FOR PLAN AND PROFILES.

REVISIONS	
NAME	DATE

ILLINOIS DEPARTMENT OF TRANSPORTATION
 GEOMETRIC DETAILS
 TR 169 / COUNTY HIGHWAY 17
 FAP 322 (US 51)
 SECTION 11-1
 CHRISTIAN COUNTY
 SCALE: 1"=50'
 DATE 3/18/05
 DRAWN BY BGJ
 CHECKED BY SEB

F.A.P. RTE.	SECTION	COUNTY	TOTAL SHEETS	SHEET NO.
322	11-10	CHRISTIAN	310	109
STA.	TO STA.			
FED. ROAD DIST. NO.	ILLINOIS	FED. AID PROJECT		

TYPICAL FINAL INTERSECTION STRIPING DETAIL

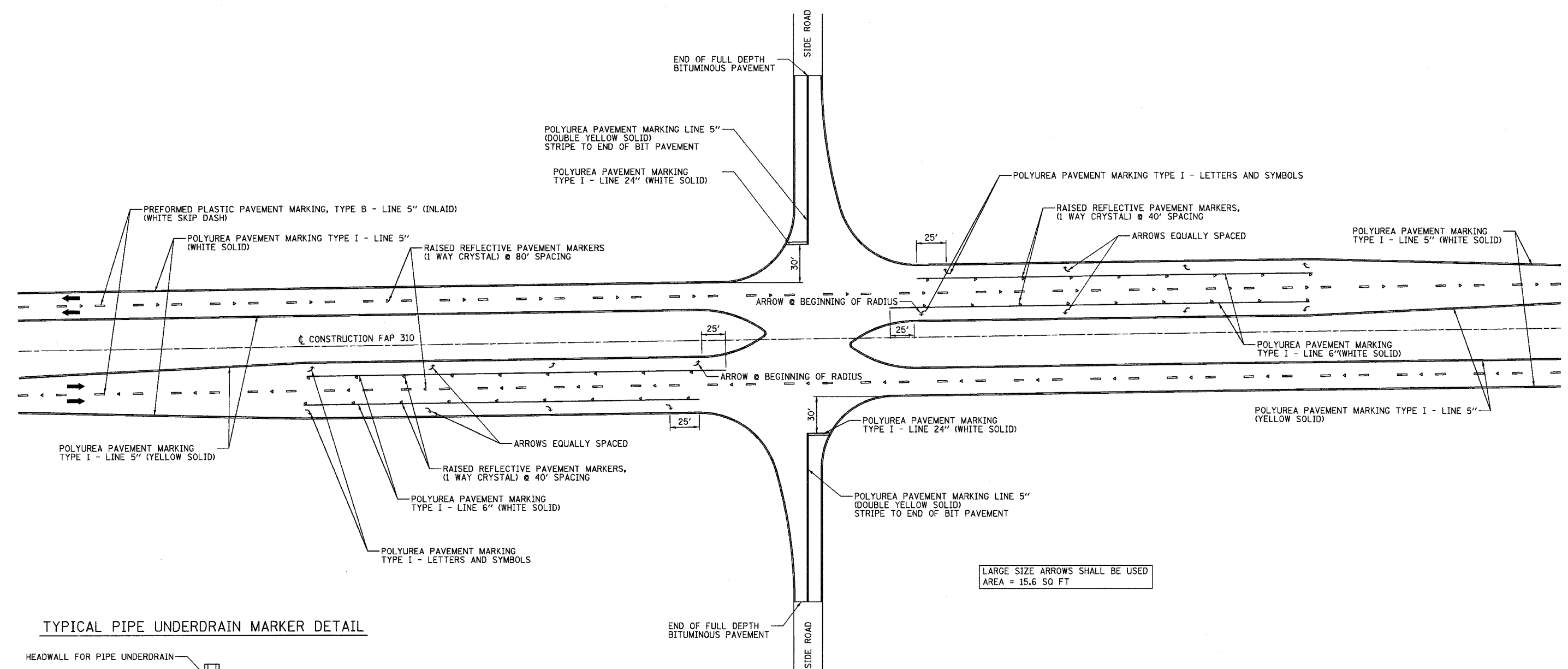

LARGE SIZE ARROWS SHALL BE USED
AREA = 15.6 SQ FT

TYPICAL PIPE UNDERDRAIN MARKER DETAIL

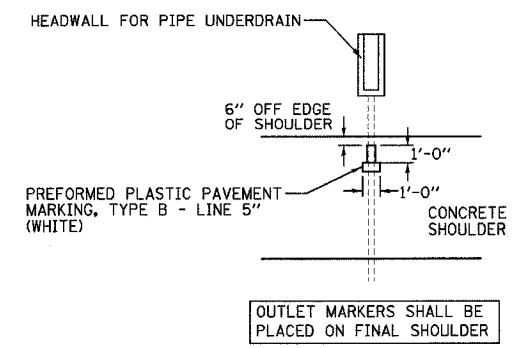

REVISIONS		ILLINOIS DEPARTMENT OF TRANSPORTATION	
NAME	DATE	SIGNING & STRIPING PLAN	
		TYPICAL STRIPING DETAILS	
		FAP 322 (US 51)	
		SECTION 11-1	
		CHRISTIAN COUNTY	
		SCALE: NONE	DRAWN BY SEB
		DATE 3/21/05	CHECKED BY EBB

F.A.P. RTE.	SECTION	COUNTY	TOTAL SHEETS	SHEET NO.
322	11-10	CHRISTIAN	310	110
STA.		TO STA.		
FED. ROAD DIST. NO.	ILLINOIS	FED. AID PROJECT		

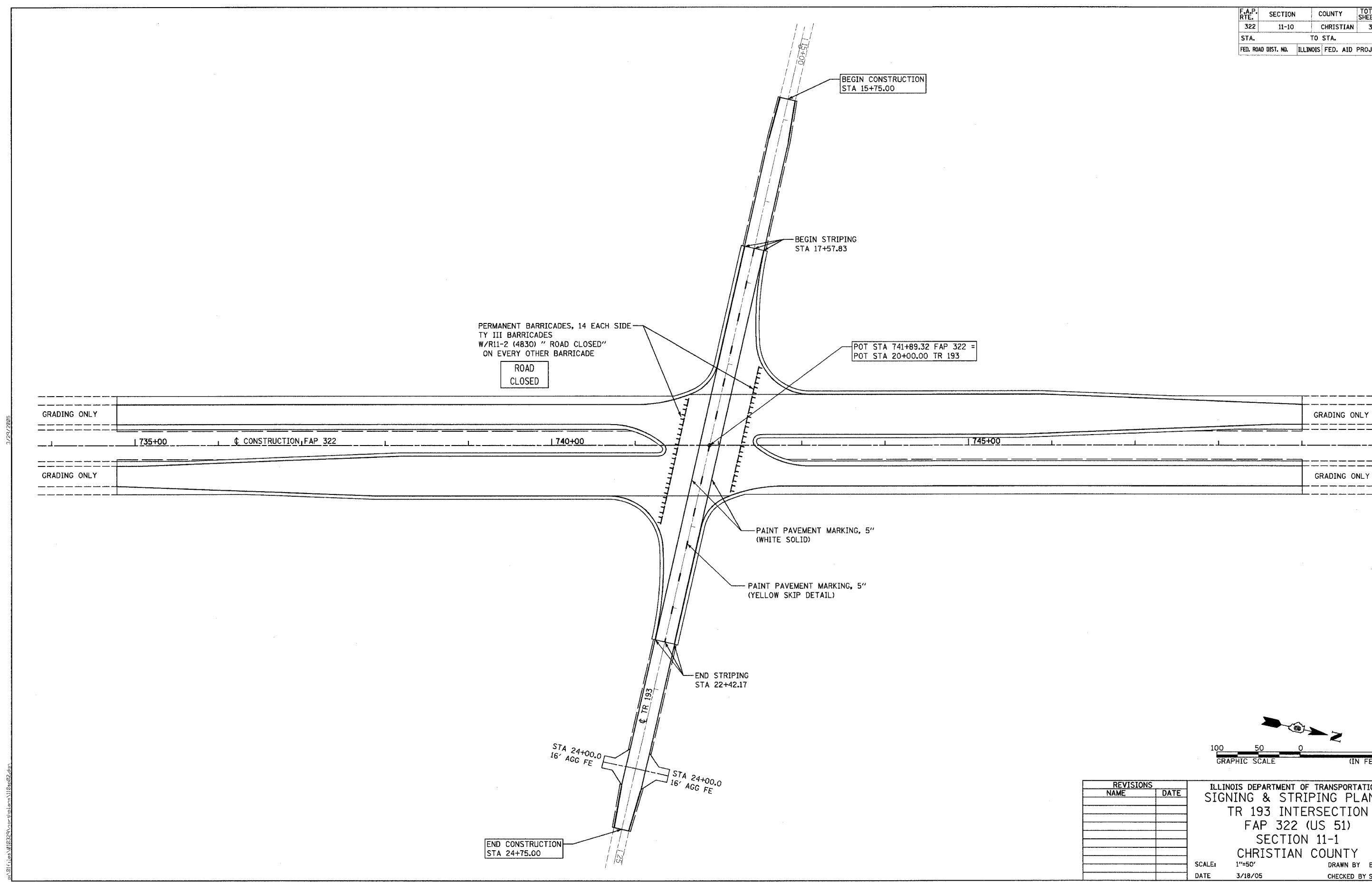

PERMANENT BARRICADES, 14 EACH SIDE
 TY III BARRICADES
 W/R11-2 (4830) "ROAD CLOSED"
 ON EVERY OTHER BARRICADE

ROAD
 CLOSED

BEGIN CONSTRUCTION
 STA 15+75.00

BEGIN STRIPING
 STA 17+57.83

POT STA 741+89.32 FAP 322 =
 POT STA 20+00.00 TR 193

PAINT PAVEMENT MARKING, 5"
 (WHITE SOLID)

PAINT PAVEMENT MARKING, 5"
 (YELLOW SKIP DETAIL)

END STRIPING
 STA 22+42.17

STA 24+00.0
 16' AGG FE

STA 24+00.0
 16' AGG FE

END CONSTRUCTION
 STA 24+75.00

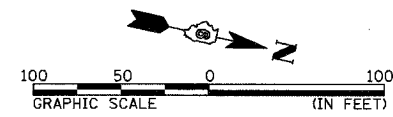

REVISIONS	
NAME	DATE

ILLINOIS DEPARTMENT OF TRANSPORTATION
 SIGNING & STRIPING PLAN -
 TR 193 INTERSECTION
 FAP 322 (US 51)
 SECTION 11-1
 CHRISTIAN COUNTY

SCALE: 1"=50'
 DATE: 3/18/05

DRAWN BY: BDJ
 CHECKED BY: SEB

3/29/2005

en:\01\11\05\1102\1102\1102\1102.dwg

F.A.P. RTE.	SECTION	COUNTY	TOTAL SHEETS	SHEET NO.
322	11-10	CHRISTIAN	310	111
STA.		TO STA.		
FED. ROAD DIST. NO.	ILLINOIS	FED. AID PROJECT		

SB TRANSITION CURVE #1 DATA:

PI STA = 101+54.01
 = 771+85.44 22.24' LT FAP 322
 $\Delta = 2^\circ 12' 21''$ (LT)
 $D = 0^\circ 42' 58''$
 $R = 8,000.00'$
 $T = 154.01'$
 $L = 307.98'$
 $E = 1.48'$
 $SE = RC$
 PC STA = 100+00.00
 = 770+32.26 24.81' LT FAP 322
 PRC STA = 103+07.98
 = 773+39.34 28.16' LT FAP 322

SB TRANSITION CURVE #2 DATA:

PI STA = 105+38.40
 = 775+69.58 37.00' LT FAP 322
 $\Delta = 2^\circ 12' 00''$ (RT)
 $D = 0^\circ 28' 39''$
 $R = 12,000.00'$
 $T = 230.42'$
 $L = 460.78'$
 $E = 2.21'$
 $SE = NC$
 PC STA = 103+07.98
 = 773+39.34 28.16' LT FAP 322
 PT STA = 107+68.76
 = 778+00.00 37.00' LT FAP 322

FAP 322 CURVE DATA:

PI STA = 763+16.39
 $\Delta = 23^\circ 21' 26''$ (RT)
 $D = 1^\circ 20' 00''$
 $R = 4,297.18'$
 $T = 888.23'$
 $L = 1,751.79'$
 $E = 90.84'$
 $SE = 4.2\%$
 PC STA = 754+28.16
 PT STA = 771+79.95
 SE ATTAINED STA 752+61 TO STA 754+91
 SE REMOVED STA 771+17 TO STA 773+47

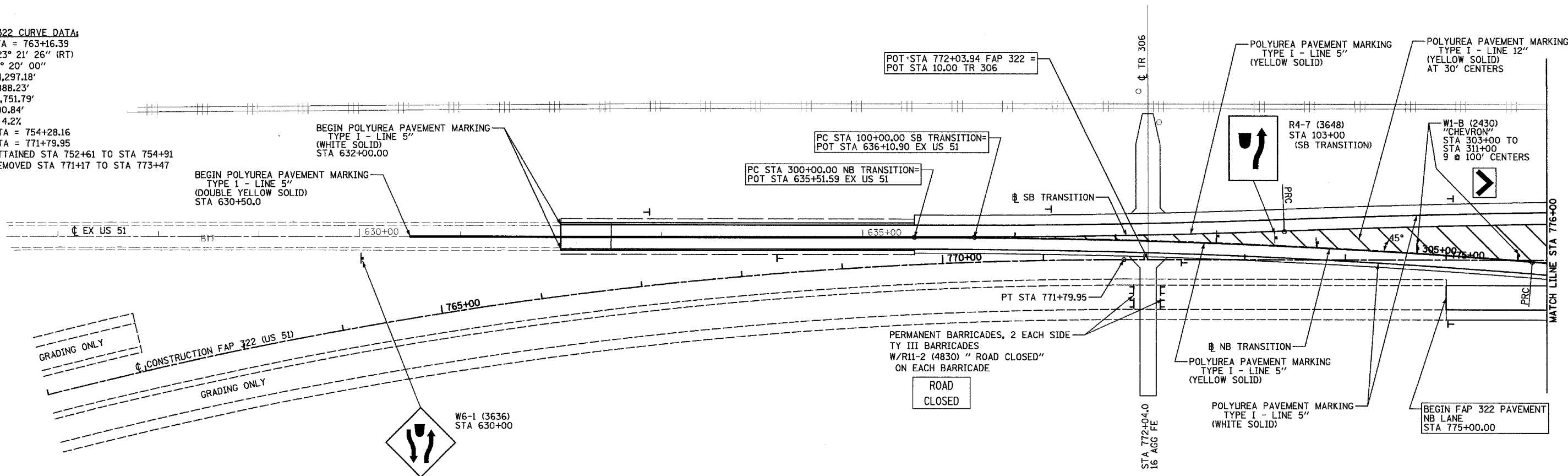

NB TRANSITION CURVE #1 DATA:

PI STA = 303+07.33
 = 772+79.16 22.23' LT FAP 322
 $\Delta = 4^\circ 23' 60''$ (RT)
 $D = 0^\circ 42' 58''$
 $R = 8,000.00'$
 $T = 307.33'$
 $L = 614.35'$
 $E = 5.90'$
 $SE = NC$
 PC STA = 300+00.00
 = 769+73.06 27.27' LT FAP 322
 PRC STA = 306+14.35
 = 775+85.58 1.37' RT FAP 322

NB TRANSITION CURVE #2 DATA:

PI STA = 309+22.17
 = 772+79.28 25.00' RT FAP 322
 $\Delta = 4^\circ 24' 20''$ (LT)
 $D = 0^\circ 42' 58''$
 $R = 8,000.00'$
 $T = 307.72'$
 $L = 615.13'$
 $E = 5.92'$
 $SE = NC$
 PC STA = 306+14.35
 = 775+85.58 1.37' RT FAP 322
 PT STA = 312+29.58
 = 782+00.00 25.00' RT FAP 322

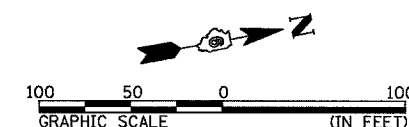

REVISIONS	
NAME	DATE
CHEVRONS - SEB	4/1/05

ILLINOIS DEPARTMENT OF TRANSPORTATION
 SIGNING & STRIPING PLANS
 STA 761+00 TO STA 776+00
 FAP 322 (US 51)
 SECTION 11-1
 CHRISTIAN COUNTY
 SCALE: 1"=50' DRAWN BY BDJ
 DATE 3/18/05 CHECKED BY SEB

4/1/2005

F.A.P. RTE.	SECTION	COUNTY	TOTAL SHEETS	SHEET NO.
322	11-10	CHRISTIAN	310	112
STA.		TO STA.		
FED. ROAD DIST. NO.		ILLINOIS FED. AID PROJECT		

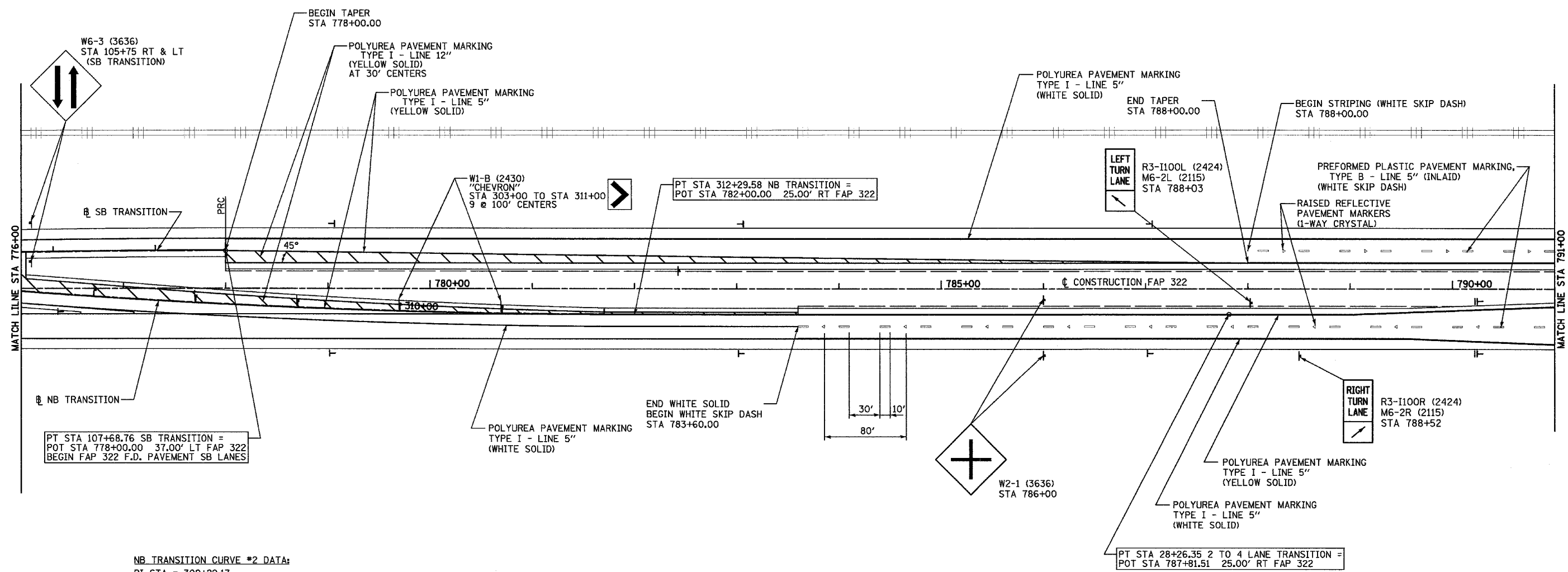

NB TRANSITION CURVE #2 DATA:
 PI STA = 309+22.17
 = 772+79.28 25.00' RT FAP 322
 $\Delta = 4^\circ 24' 20''$ (LT)
 $D = 0^\circ 42' 58''$
 $R = 8,000.00'$
 $T = 307.72'$
 $L = 615.13'$
 $E = 5.92'$
 SE = NC
 PRC STA = 306+14.35
 = 775+85.58 1.37' RT FAP 322
 PT STA = 312+29.58
 = 782+00.00 25.00' RT FAP 322

DELINEATOR SYMBOLS:
 I - SINGLE
 II - DOUBLE

REVISIONS	
NAME	DATE
CHEVRONS - SEB	4/1/05

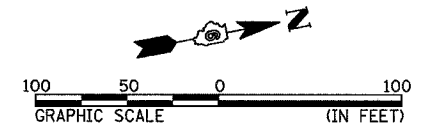

ILLINOIS DEPARTMENT OF TRANSPORTATION
 SIGNING & STRIPING PLAN
 STA 776+00 TO STA 791+00
 FAP 322 (US 51)
 SECTION 11-1
 CHRISTIAN COUNTY
 SCALE: 1"=50'
 DATE: 3/18/05
 DRAWN BY: BDJ
 CHECKED BY: SEB

F.A.P. RTE.	SECTION	COUNTY	TOTAL SHEETS	SHEET NO.
322	11-10	CHRISTIAN	310	113
STA. TO STA.		FED. ROAD DIST. NO. ILLINOIS FED. AID PROJECT		

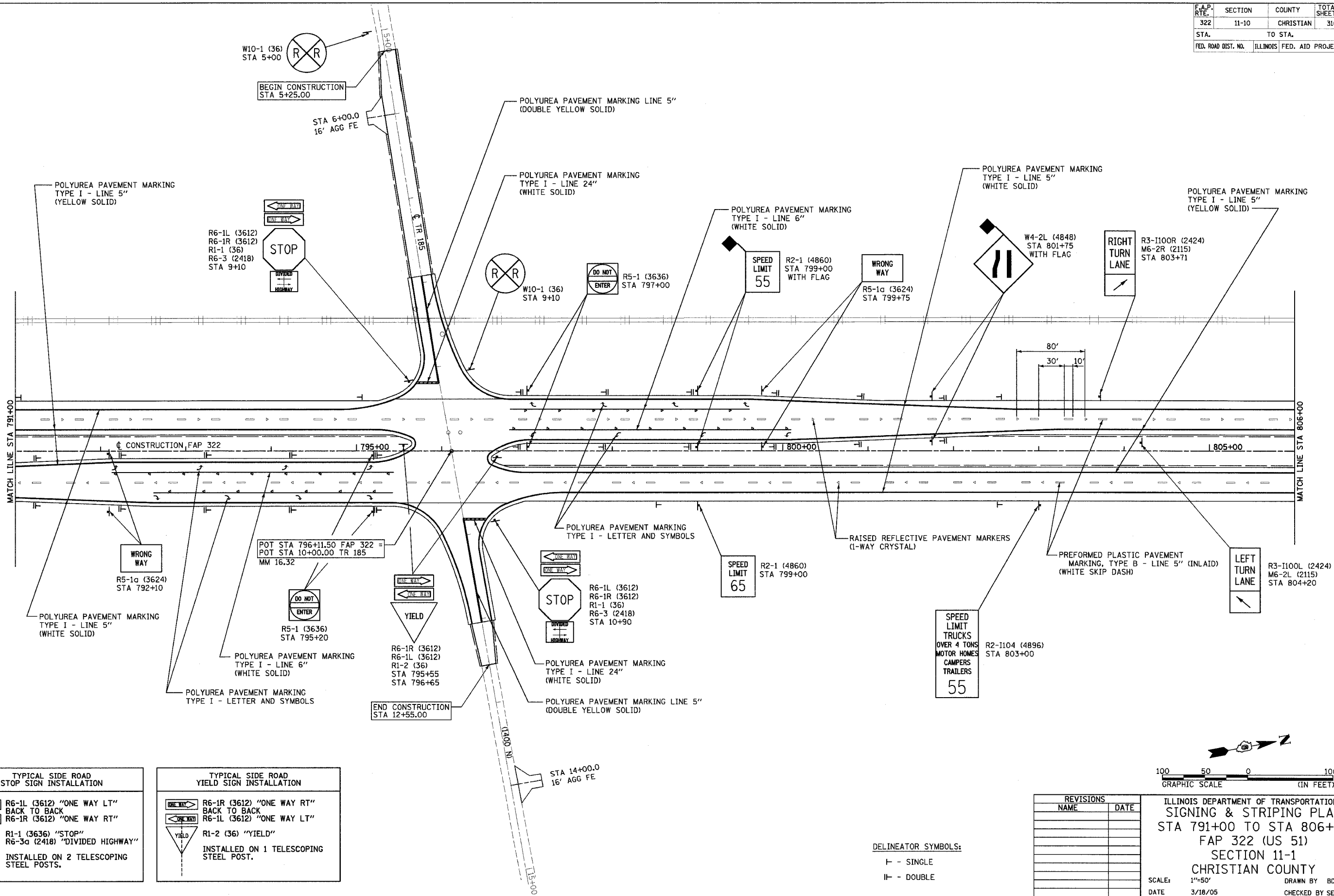

TYPICAL SIDE ROAD STOP SIGN INSTALLATION	TYPICAL SIDE ROAD YIELD SIGN INSTALLATION
<p>R6-1L (3612) "ONE WAY LT" BACK TO BACK R6-1R (3612) "ONE WAY RT" R1-1 (3636) "STOP" R6-3a (2418) "DIVIDED HIGHWAY" INSTALLED ON 2 TELESCOPING STEEL POSTS.</p>	<p>R6-1R (3612) "ONE WAY RT" BACK TO BACK R6-1L (3612) "ONE WAY LT" R1-2 (36) "YIELD" INSTALLED ON 1 TELESCOPING STEEL POST.</p>

DELINATOR SYMBOLS:
 I - SINGLE
 II - DOUBLE

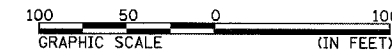

REVISIONS	
NAME	DATE

ILLINOIS DEPARTMENT OF TRANSPORTATION
 SIGNING & STRIPING PLAN
 STA 791+00 TO STA 806+00
 FAP 322 (US 51)
 SECTION 11-1
 CHRISTIAN COUNTY

SCALE: 1"=50'
 DATE: 3/18/05
 DRAWN BY: BDJ
 CHECKED BY: SEB

3/25/2005

F.A.P. RTE.	SECTION	COUNTY	TOTAL SHEETS	SHEET NO.
322	11-10	CHRISTIAN	310	114
STA.		TO STA.		
FED. ROAD DIST. NO.	ILLINOIS	FED. AID PROJECT		

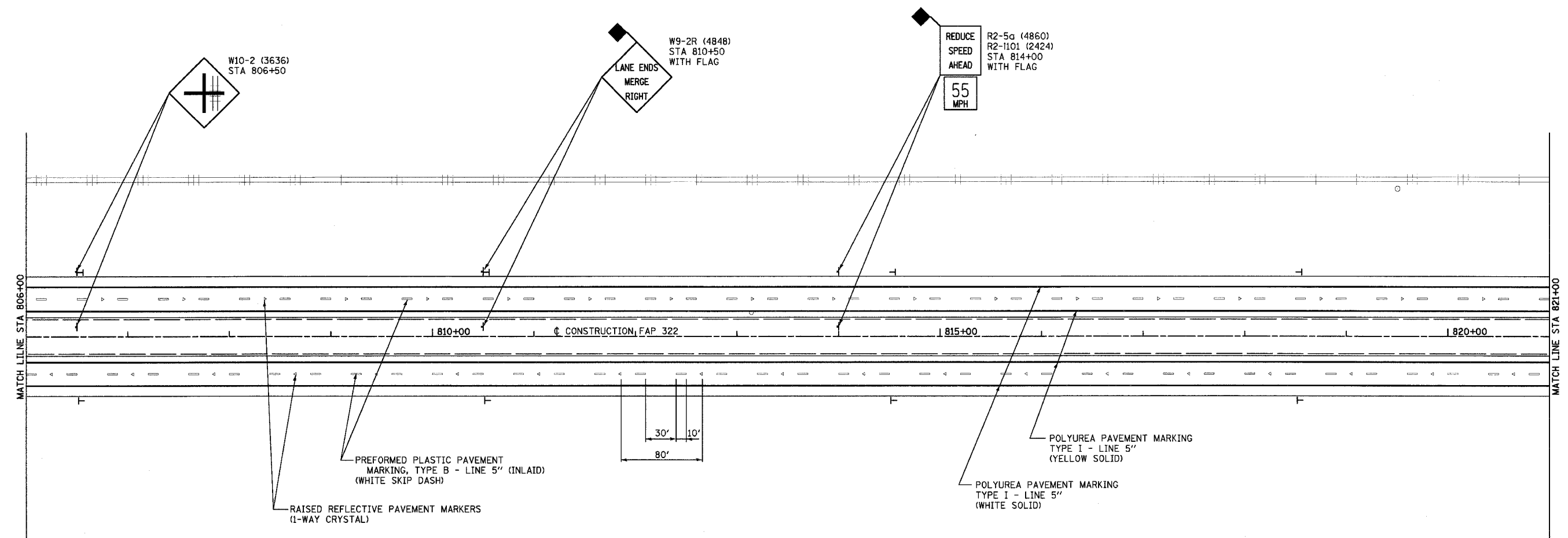

3/21/2005

P:\GIS\Files\01224\constr\plan\114sig11.dwg

RAISED REFLECTIVE PAVEMENT MARKERS
(1-WAY CRYSTAL)

PREFORMED PLASTIC PAVEMENT
MARKING, TYPE B - LINE 5" (INLAID)
(WHITE SKIP DASH)

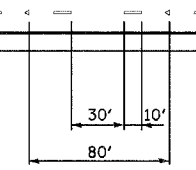

POLYUREA PAVEMENT MARKING
TYPE I - LINE 5" (YELLOW SOLID)

POLYUREA PAVEMENT MARKING
TYPE I - LINE 5" (WHITE SOLID)

DELINEATOR SYMBOLS:
┆ - SINGLE
|| - DOUBLE

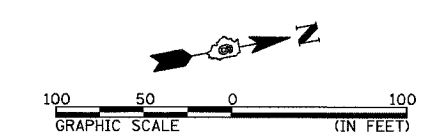

REVISIONS	
NAME	DATE

ILLINOIS DEPARTMENT OF TRANSPORTATION
SIGNING & STRIPING PLAN
STA 806+00 TO STA 821+00
FAP 322 (US 51)
SECTION 11-1
CHRISTIAN COUNTY

SCALE: 1"=50'
DATE: 3/18/05

DRAWN BY: BDJ
CHECKED BY: SEB

F.A.P. RTE.	SECTION	COUNTY	TOTAL SHEETS	SHEET NO.
322	11-10	CHRISTIAN	310	115
STA.		TO STA.		
FED. ROAD DIST. NO.		ILLINOIS	FED. AID PROJECT	

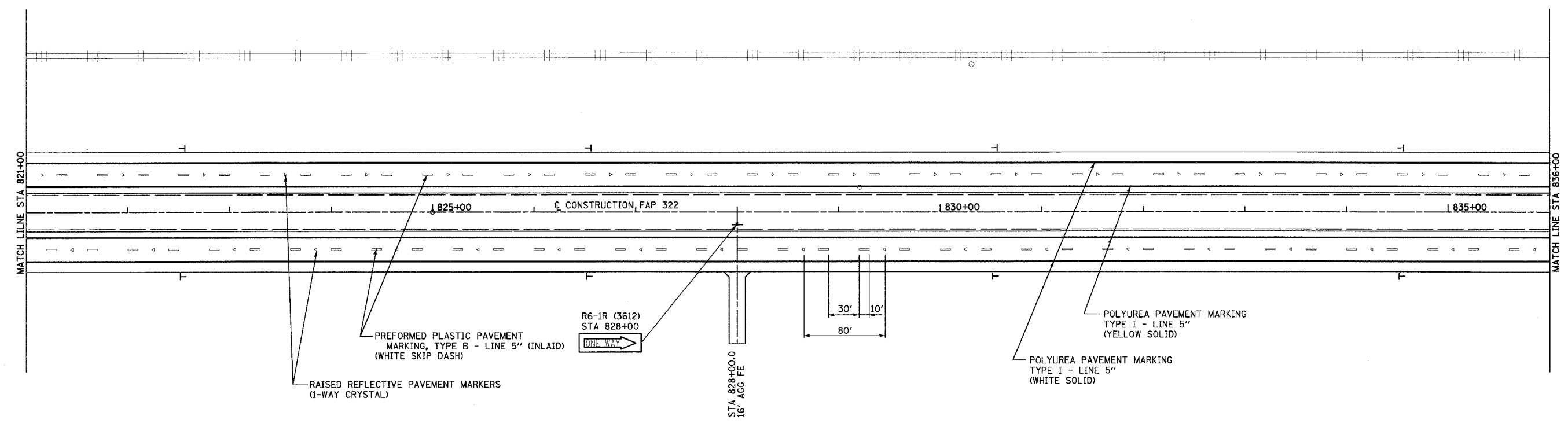

3/21/2005

\\s1\files\100224\user\bdj\115187.dwg



DELINEATOR SYMBOLS:
 T - SINGLE
 II - DOUBLE

REVISIONS	
NAME	DATE

ILLINOIS DEPARTMENT OF TRANSPORTATION
 SIGNING & STRIPING PLAN
 STA 821+00 TO STA 836+00
 FAP 322 (US 51)
 SECTION 11-1
 CHRISTIAN COUNTY

SCALE: 1"=50'
 DATE: 3/18/05

DRAWN BY: BDJ
 CHECKED BY: SEB

F.A.P. RTE.	SECTION	COUNTY	TOTAL SHEETS	SHEET NO.
322	11-10	CHRISTIAN	310	116
STA.	TO STA.			
FED. ROAD DIST. NO.	ILLINOIS	FED. AID PROJECT		

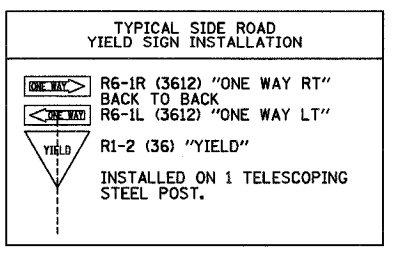
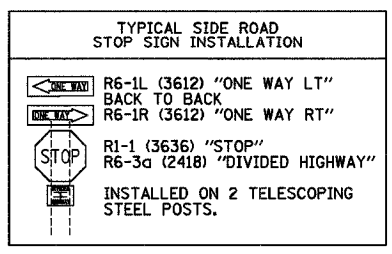
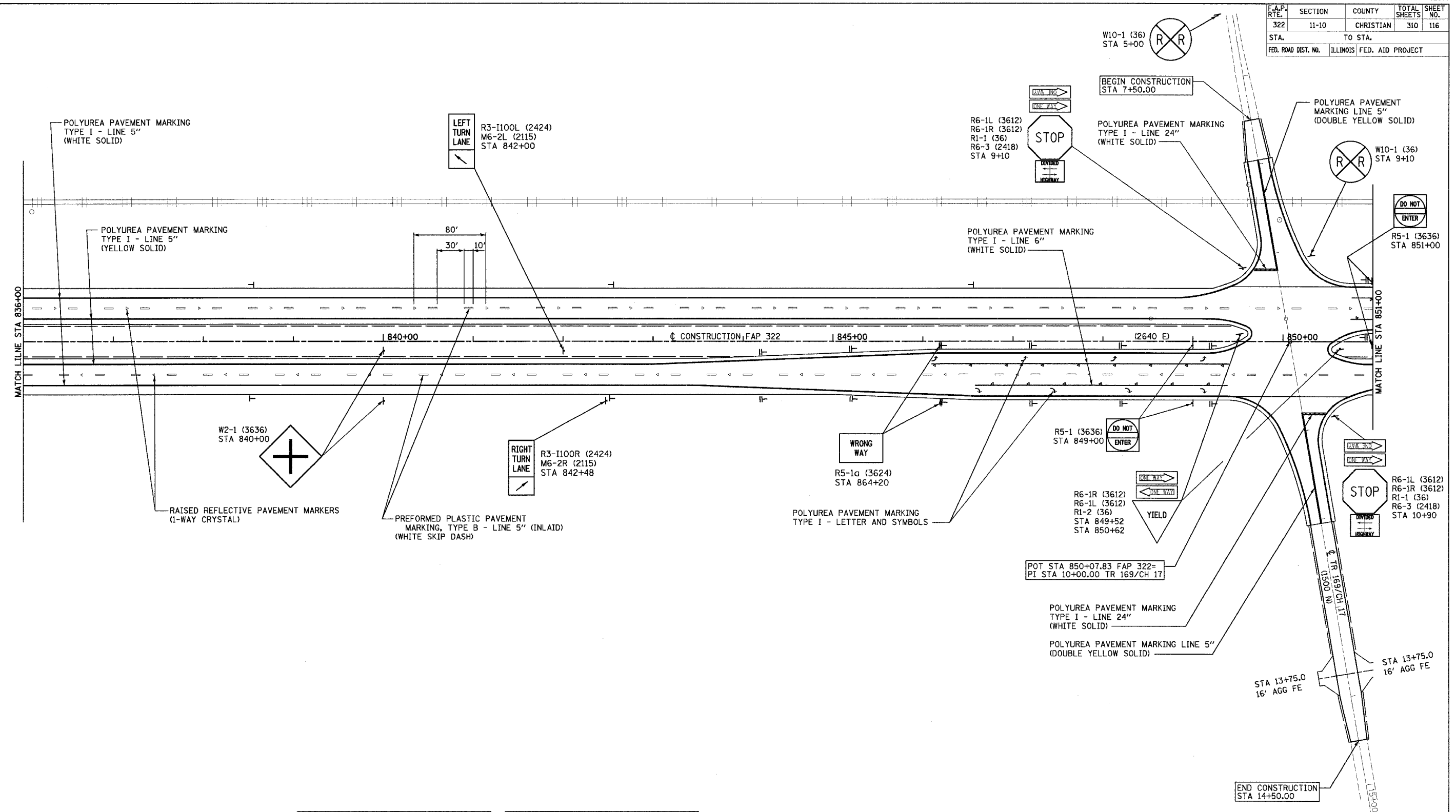

DELINEATOR SYMBOLS:
 I - SINGLE
 II - DOUBLE

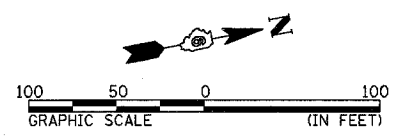

REVISIONS	
NAME	DATE

ILLINOIS DEPARTMENT OF TRANSPORTATION
SIGNING & STRIPING PLAN
 STA 836+00 TO STA 851+00
 FAP 322 (US 51)
 SECTION 11-1
 CHRISTIAN COUNTY

SCALE: 1"=50'
 DATE: 3/18/05

DRAWN BY: BDJ
 CHECKED BY: SEB

3/24/2005

F.A.P. RTE.	SECTION	COUNTY	TOTAL SHEETS	SHEET NO.
322	11-10	CHRISTIAN	310	117
STA.		TO STA.		
FED. ROAD DIST. NO.	ILLINOIS	FED. AID PROJECT		

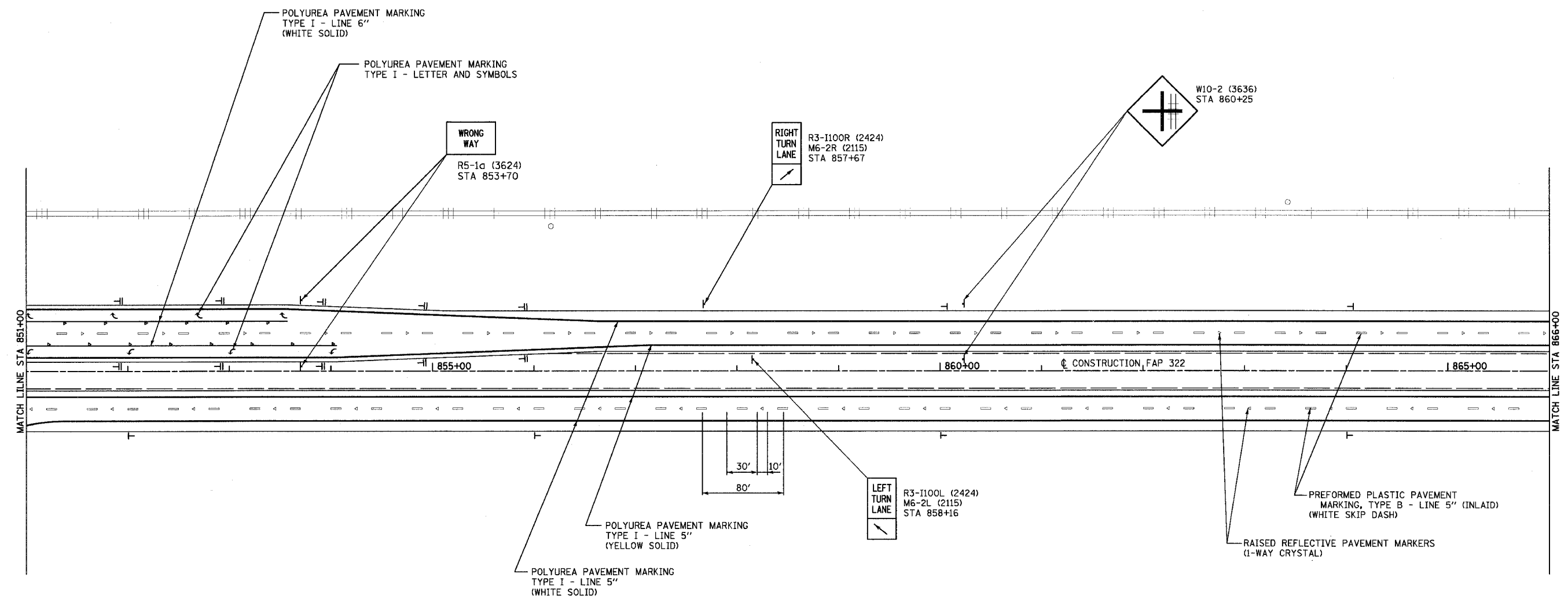

DELINEATOR SYMBOLS:
 T - SINGLE
 || - DOUBLE

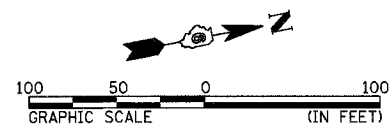

REVISIONS	
NAME	DATE

ILLINOIS DEPARTMENT OF TRANSPORTATION
 SIGNING & STRIPING PLAN
 STA 851+00 TO STA 866+00
 FAP 322 (US 51)
 SECTION 11-1
 CHRISTIAN COUNTY

SCALE: 1"=50'
 DATE: 3/18/05

DRAWN BY: BDJ
 CHECKED BY: SEB

3/25/2005

\\s1\files\1110\1110-11-10\1110-11-10.dwg

F.A.P. RTE.	SECTION	COUNTY	TOTAL SHEETS	SHEET NO.
322	11-10	CHRISTIAN	310	119
STA.		TO STA.		
FED. ROAD DIST. NO.		ILLINOIS FED. AID PROJECT		

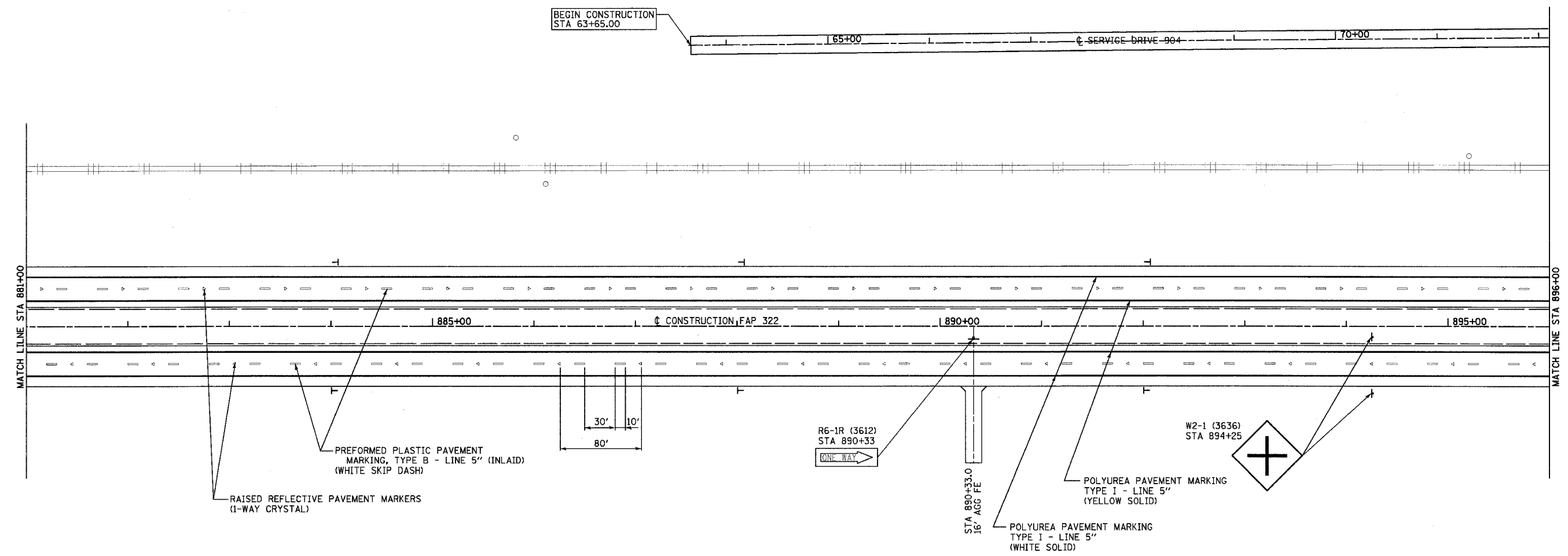

RAISED REFLECTIVE PAVEMENT MARKERS (1-WAY CRYSTAL)

PREFORMED PLASTIC PAVEMENT MARKING, TYPE B - LINE 5" (INLAID) (WHITE SKIP DASH)

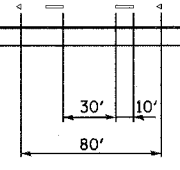

R6-1R (3612)
STA 890+33

STA 890+33.0
16' AGG FE

POLYUREA PAVEMENT MARKING
TYPE I - LINE 5" (WHITE SOLID)

W2-1 (3636)
STA 894+25

POLYUREA PAVEMENT MARKING
TYPE I - LINE 5" (YELLOW SOLID)

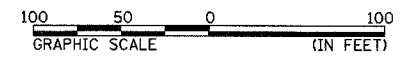

DELINEATOR SYMBOLS:
F - SINGLE
H - DOUBLE

REVISIONS	
NAME	DATE

ILLINOIS DEPARTMENT OF TRANSPORTATION
SIGNING & STRIPING PLAN
STA 881+00 TO STA 896+00
FAP 322 (US 51)
SECTION 11-1
CHRISTIAN COUNTY

SCALE: 1"=50'
DATE: 3/18/05

DRAWN BY: BDJ
CHECKED BY: SEB

3/29/2005

ps:\011\11-10\11-10\11-10-119.dgn

F.A.P. RTE.	SECTION	COUNTY	TOTAL SHEETS	SHEET NO.
322	11-10	CHRISTIAN	310	120
STA.		TO STA.		
FED. ROAD DIST. NO.		ILLINOIS FED. AID PROJECT		

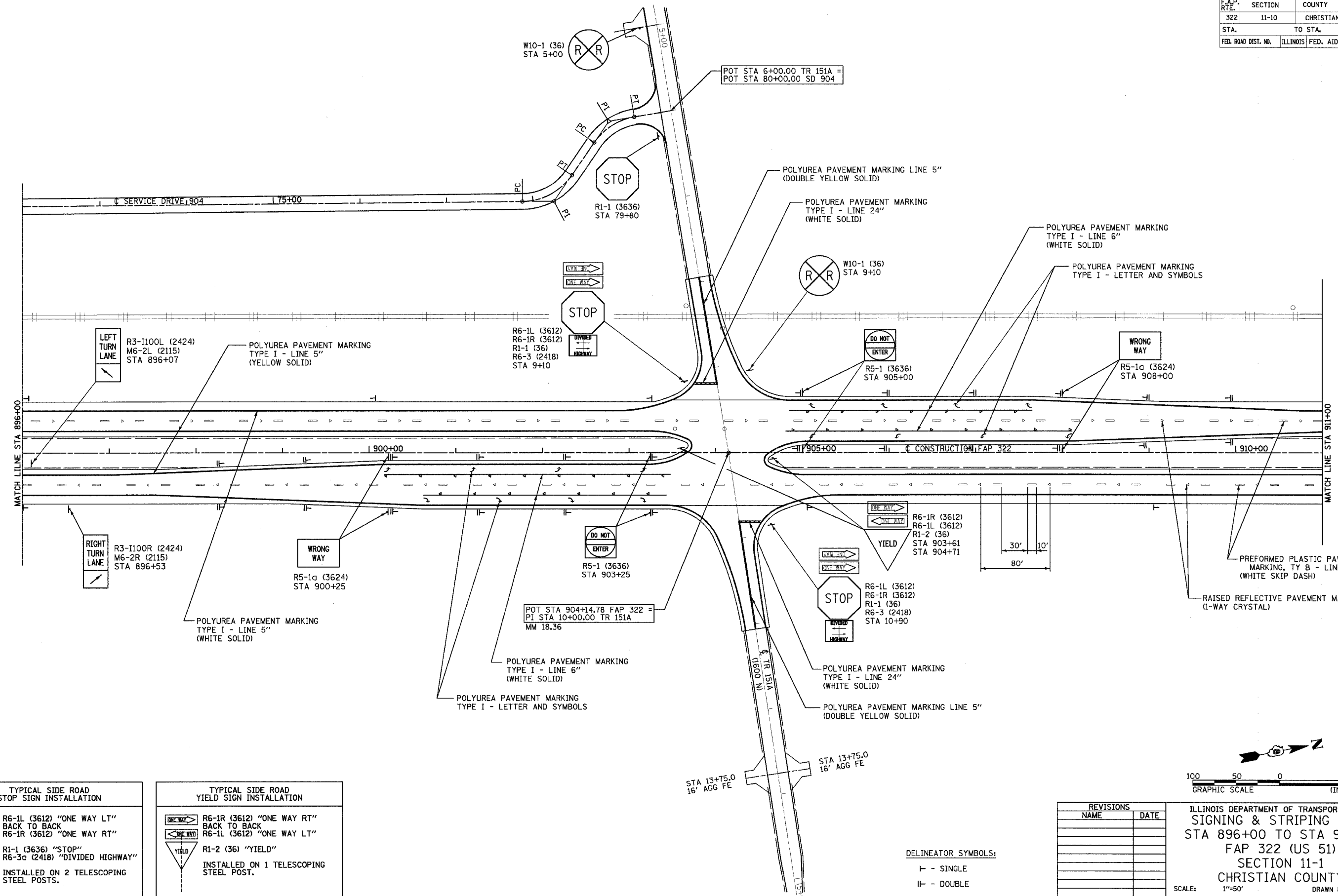

TYPICAL SIDE ROAD STOP SIGN INSTALLATION

R6-1L (3612) "ONE WAY LT" BACK TO BACK
 R6-1R (3612) "ONE WAY RT"
 R1-1 (3636) "STOP"
 R6-3a (2418) "DIVIDED HIGHWAY"
 INSTALLED ON 2 TELESCOPING STEEL POSTS.

TYPICAL SIDE ROAD YIELD SIGN INSTALLATION

R6-1R (3612) "ONE WAY RT" BACK TO BACK
 R6-1L (3612) "ONE WAY LT"
 R1-2 (36) "YIELD"
 INSTALLED ON 1 TELESCOPING STEEL POST.

DELINEATOR SYMBOLS:
 I - SINGLE
 II - DOUBLE

REVISIONS	
NAME	DATE

ILLINOIS DEPARTMENT OF TRANSPORTATION
SIGNING & STRIPING PLAN
 STA 896+00 TO STA 911+00
 FAP 322 (US 51)
 SECTION 11-1
 CHRISTIAN COUNTY

SCALE: 1"=50'
 DATE: 3/18/05

DRAWN BY: BDJ
 CHECKED BY: SEB

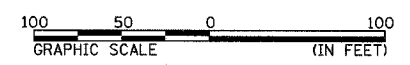

3/25/2005

D:\322\11-10\120.dwg

F.A.P. RTE.	SECTION	COUNTY	TOTAL SHEETS	SHEET NO.
322	11-10	CHRISTIAN	310	121
STA.		TO STA.		
FED. ROAD DIST. NO.	ILLINOIS	FED. AID PROJECT		

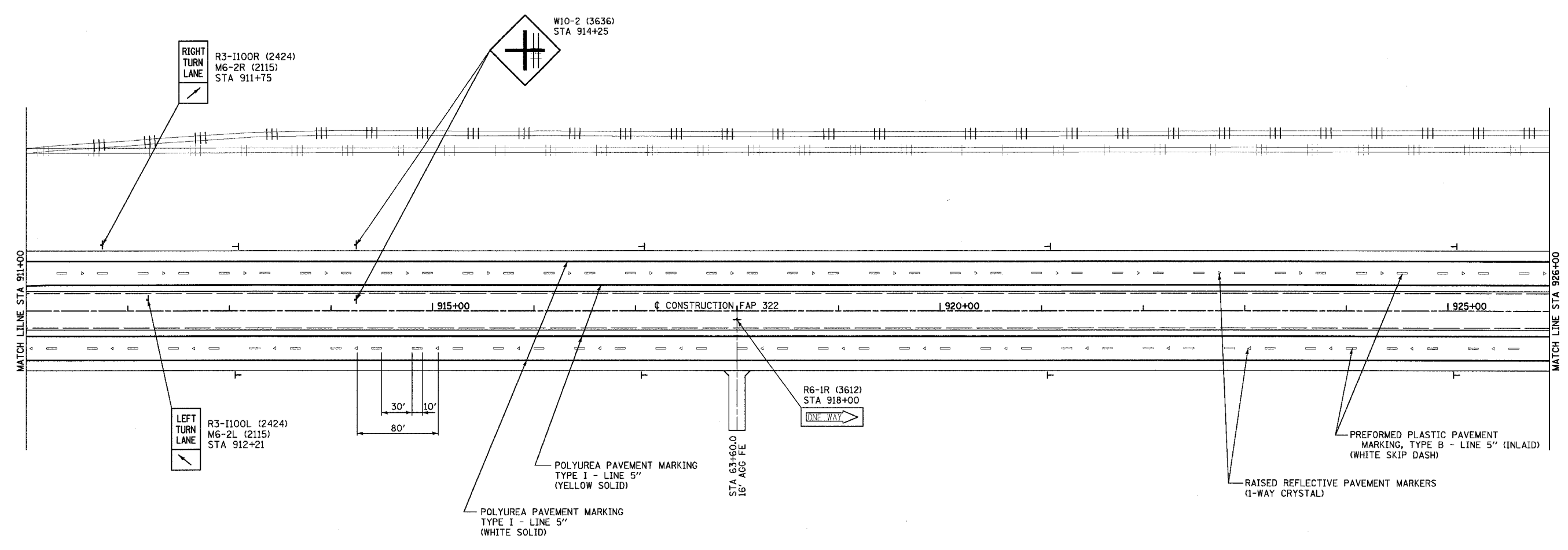

3/25/2005

pa:\bl\lans\010224\constrplan\1121ap13.dwg

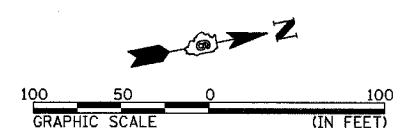

DELINEATOR SYMBOLS:
 T - SINGLE
 H - DOUBLE

REVISIONS	
NAME	DATE

ILLINOIS DEPARTMENT OF TRANSPORTATION
 SIGNING & STRIPING PLAN
 STA 911+00 TO STA 926+00
 FAP 322 (US 51)
 SECTION 11-1
 CHRISTIAN COUNTY

SCALE: 1"=50'
 DATE: 3/18/05

DRAWN BY: BDJ
 CHECKED BY: SEB

F.A.P. RTE.	SECTION	COUNTY	TOTAL SHEETS	SHEET NO.
322	11-10	CHRISTIAN	310	122
STA.		TO STA.		
FED. ROAD DIST. NO.		ILLINOIS FED. AID PROJECT		

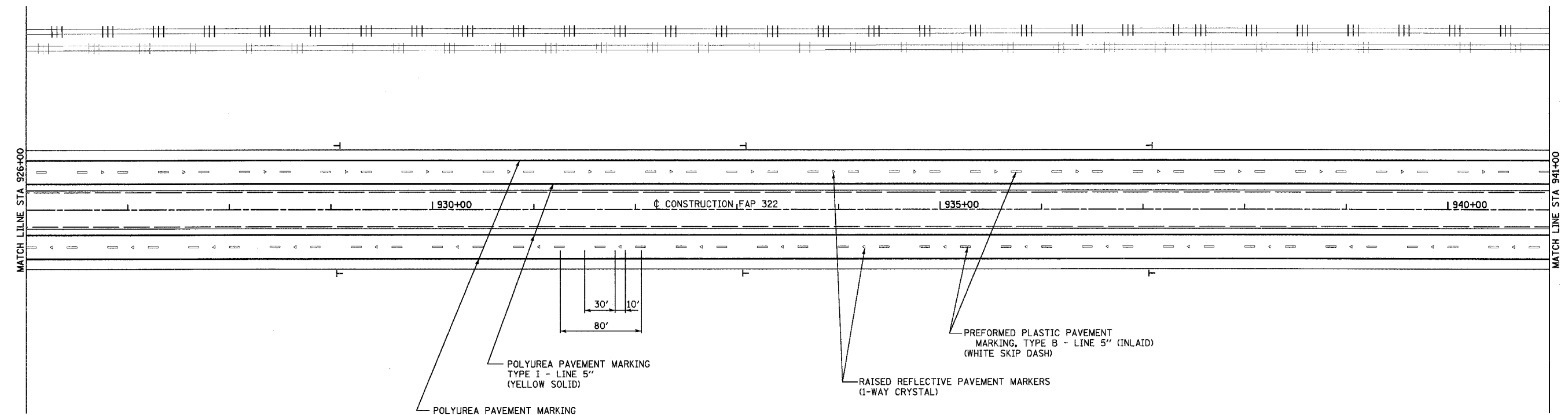

POLYUREA PAVEMENT MARKING
TYPE I - LINE 5"
(WHITE SOLID)

POLYUREA PAVEMENT MARKING
TYPE I - LINE 5"
(YELLOW SOLID)

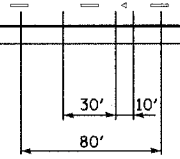

RAISED REFLECTIVE PAVEMENT MARKERS
(1-WAY CRYSTAL)

PREFORMED PLASTIC PAVEMENT
MARKING, TYPE B - LINE 5" (INLAID)
(WHITE SKIP DASH)

3/29/2005

\\s011\lans\10\1025\working\lans\122\sp1.dwg

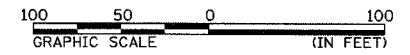

DELINEATOR SYMBOLS:
 T - SINGLE
 I - DOUBLE

REVISIONS	
NAME	DATE

ILLINOIS DEPARTMENT OF TRANSPORTATION
 SIGNING & STRIPING PLAN
 STA 926+00 TO STA 941+00
 FAP 322 (US 51)
 SECTION 11-1
 CHRISTIAN COUNTY

SCALE: 1"=50'
 DATE: 3/18/05

DRAWN BY: BDJ
 CHECKED BY: SEB

F.A.P. RTE.	SECTION	COUNTY	TOTAL SHEETS	SHEET NO.
322	11-10	CHRISTIAN	310	123
STA.		TO STA.		
FED. ROAD DIST. NO.	ILLINOIS	FED. AID PROJECT		

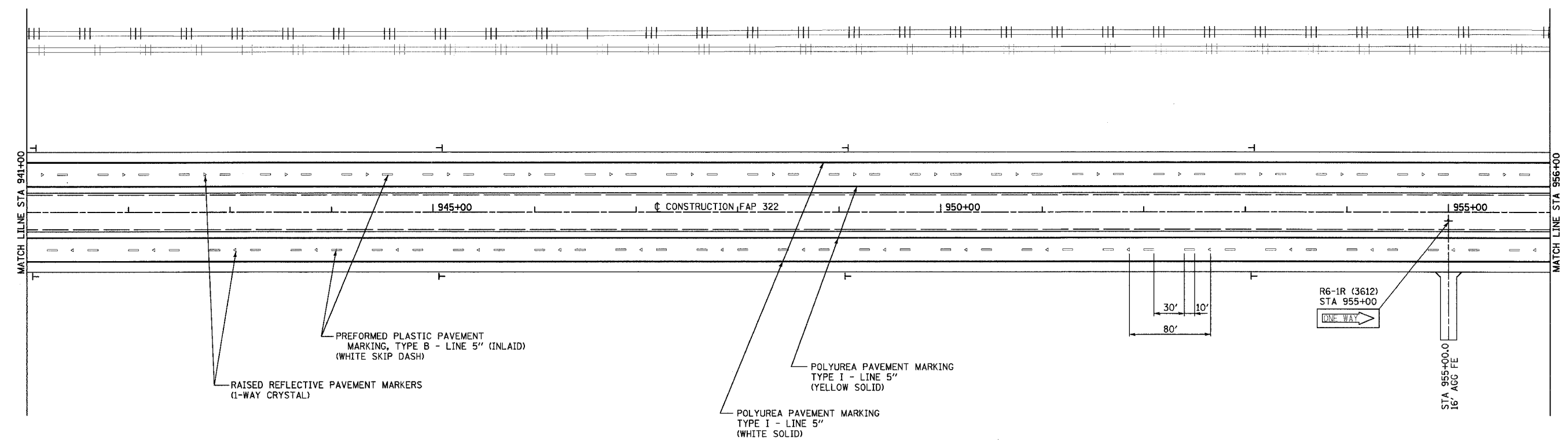

RAISED REFLECTIVE PAVEMENT MARKERS
(1-WAY CRYSTAL)

PREFORMED PLASTIC PAVEMENT
MARKING, TYPE B - LINE 5" (INLAID)
(WHITE SKIP DASH)

POLYUREA PAVEMENT MARKING
TYPE I - LINE 5" (YELLOW SOLID)

POLYUREA PAVEMENT MARKING
TYPE I - LINE 5" (WHITE SOLID)

R6-1R (3612)
STA 955+00
ONE WAY

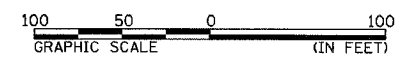

DELINEATOR SYMBOLS:
I - SINGLE
II - DOUBLE

REVISIONS	
NAME	DATE

ILLINOIS DEPARTMENT OF TRANSPORTATION
SIGNING & STRIPING PLAN
STA 941+00 TO STA 956+00
FAP 322 (US 51)
SECTION 11-1
CHRISTIAN COUNTY

SCALE: 1"=50'
DATE: 3/18/05

DRAWN BY: BDJ
CHECKED BY: SEB

3/25/2005

h:\bl\lans\010225\new\striping\1123apl12.dgn

F.A.P. RTE.	SECTION	COUNTY	TOTAL SHEETS	SHEET NO.
322	11-10	CHRISTIAN	310	127
STA.		TO STA.		
FED. ROAD DIST. NO.		ILLINOIS FED. AID PROJECT		

LIGHT POLE MOUNTING HEIGHT	BOLT CIRCLE DIAMETER	STEEL FOUNDATION			CONCRETE FOUNDATION		
		SHAFT DIAMETER	SHAFT DEPTH	TOP PLATE (min)	SHAFT DIAMETER	SHAFT DEPTH	ANCHOR ROD LENGTH ①
<9.1 m (30')	292 (11.5)	220 (8 5/8)	1.83 m (6')	300 x 300 x 25 12 x 12 x 1	610 (24)	1.52 m (5'-0")	1.45 m (4'-9")
9.4 m - 10.7 m (31'-35')	292 (11.5)	220 (8 5/8)	1.83 m (6')	300 x 300 x 25 12 x 12 x 1	610 (24)	1.67 m (5'-6")	1.60 m (5'-3")
10.9 m - 12.2 m (36'-40')	381 (15) ③	220 (8 5/8)	1.83 m (6') ②	375 x 375 x 31 15 x 15 x 1 1/4	762 (30)	1.83 m (6'-0")	1.75 m (5'-9")
12.5 m - 13.7 m (41'-45')	381 (15) ③	220 (8 5/8)	1.83 m (6') ②	375 x 375 x 31 15 x 15 x 1 1/4	762 (30)	1.98 m (6'-6")	1.90 m (6'-3")
14.0 m - 15.2 m (46'-50')	381 (15) ③	220 (8 5/8)	2.44 m (8')	375 x 375 x 31 15 x 15 x 1 1/4	762 (30)	2.13m (7'-0")	2.00 m (6'-9")

- ① Length does not include 100(4)hook
- ② 220 mm x 2.44 m (8 5/8" x 8'-0") for Twin luminaires
- ③ Bolt circle diam. shall be 430 (17) when a TB3-17 transformer base is used

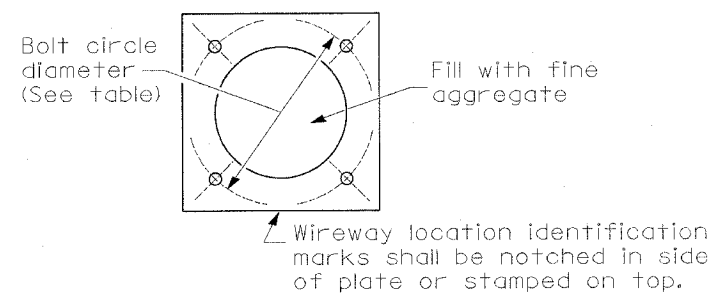

Length above foundation shall be adjusted to accommodate breakaway devices furnished by the contractor for a specific installation.

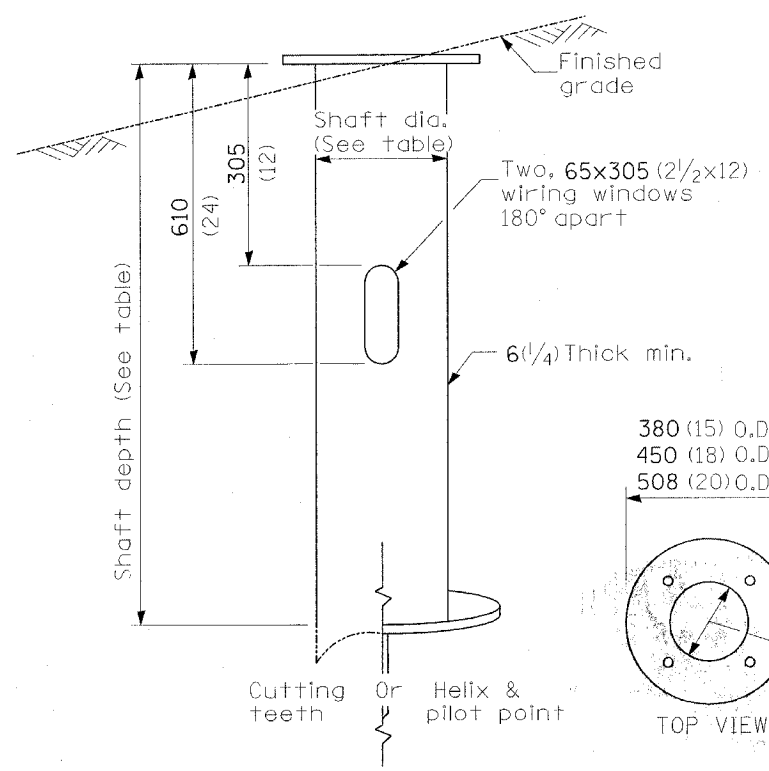

STEEL FOUNDATION

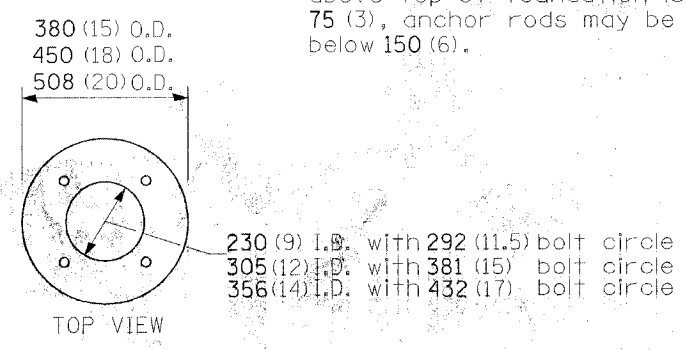

RING PLATE DETAIL
(When rock is encountered and foundation is shallower)

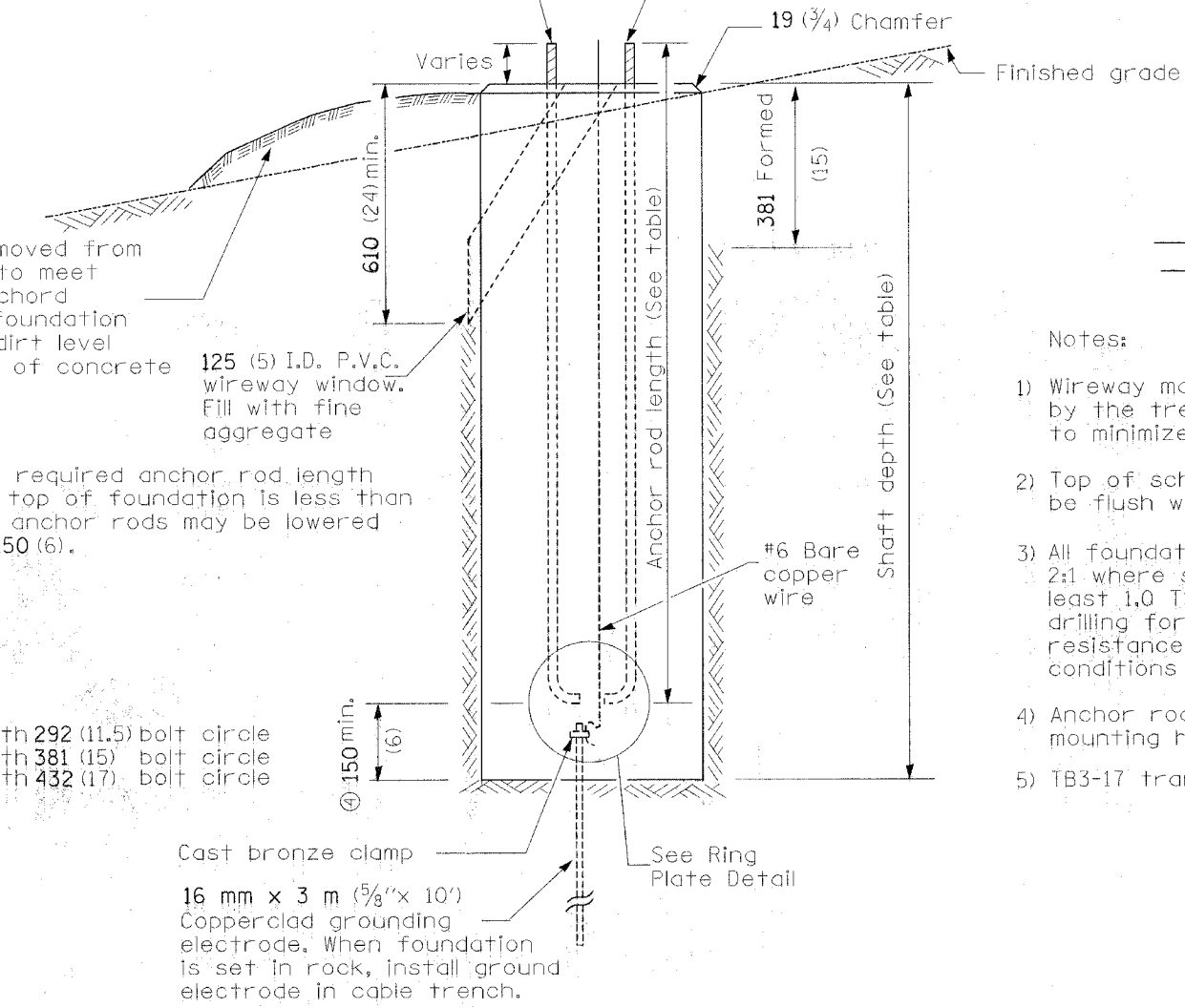

CONCRETE FOUNDATION

610 (24) min. dia. with 292 (11.5) bolt circle
762 (30) min. dia. with 381 (15) or 432 (17) bolt circle

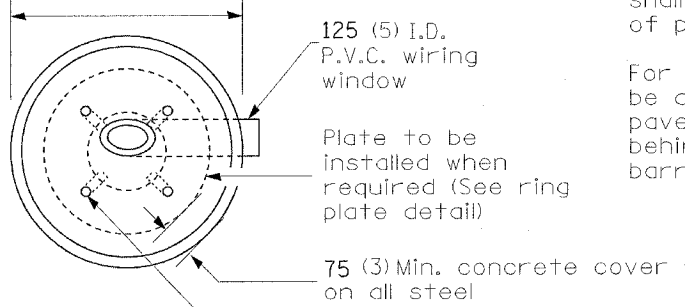

Anchor rod 25 (1) diameter with 230 (9) threads. Anchor rod shall extend through nut 25 (1). For barrier or foundation behind guardrail, use self-locking nut and flat washer. Do not use lock washer.

Pole Foundation Setback:

For horizontal mounted luminaires, setback shall be a minimum of 6.1 m (20') from edge of pavement.
For vertical mount luminaires, setback shall be a minimum of 9 m (30') from edge of pavement. Poles shall be located 1.5 m (5') behind guardrail or other protective barriers, or as directed by the Engineer.

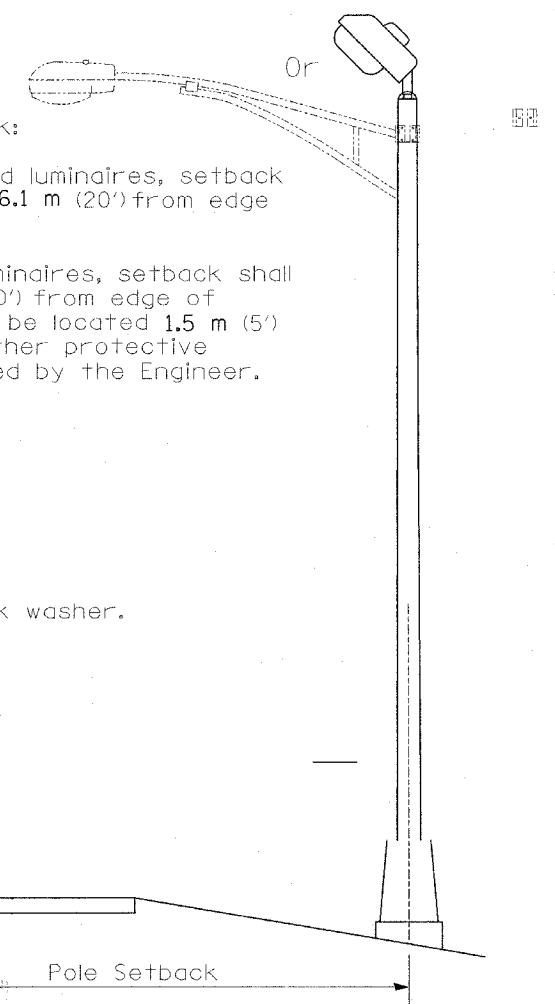

Notes:

- 1) Wireway may be on front, back or side of foundation as required by the trenching. Place door of transformer base on wireway side to minimize the number of unit duct bends.
- 2) Top of schedule 40 125 (5) I.D. PVC wiring window, shall be flush with the top of foundation for drainage.
- 3) All foundations are designed to be located on slopes not exceeding 2:1 where soils have an unconfined compressive strength of at least 1.0 TSF. The contractor shall verify the soil strength during drilling for concrete foundations or by monitoring installation resistance on steel foundations and notify the engineer if other conditions are encountered.
- 4) Anchor rod shall be increased to 31 (1 1/4) diameter for 15.24 (50') mounting height or above.
- 5) TB3-17 transformer base is not to be used on metal foundation

LIGHT POLE FOUNDATION

REVISIONS	
NAME	DATE

ILLINOIS DEPARTMENT OF TRANSPORTATION
LIGHTING PLAN -
LIGHTING DETAILS 2 OF 5
FAP 322 (US 51)
SECTION 11-10
CHRISTIAN COUNTY

SCALE: VERT. HORIZ.
DATE

DRAWN BY
CHECKED BY

F.A.P. RTE.	SECTION	COUNTY	TOTAL SHEETS	SHEET NO.
322	11-10	CHRISTIAN	310	128
STA.		TO STA.		
FED. ROAD DIST. NO.		ILLINOIS FED. AID PROJECT		

"Install and orient arm bracket over pole tenon and firmly hand tighten the two set screws. Use third hole in arm bracket as a guide to drill a 8.3 (3/4) diameter hole through tenon. Install and tighten self-tapping screw. Tighten set screws an additional (1/4 to 3/8) turn with hex key (not provided). Install locknuts on set screws if threaded projection allows."

Pole shall meet AASHTO Standard Specifications for 128.72 km (80 mph) wind loading and 40.82 kg (90 lb.), .37 m² (4.0 sq. ft.) E.P.A. luminaire.

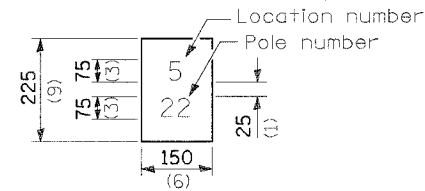

The contractor shall furnish and install a light pole identification of each new light pole, as shown above, incidental to the respective light pole pay item. The numerals shall be 75 (3) series "D", black, screened on silver-white type B pressure sensitive reflective sheeting conforming to the requirements of section T602.01 of the Standard Specifications for Traffic Control Items. The numerals shall conform to the FHWA "Standard Alphabets for Highway Signs".

The light pole identification shall be applied to sign base material as specified in section 1085.05 of the Standard Specifications, approximately 180 (7) above the adjacent pavement grade visible to approaching traffic in accordance with Highway Standard 2319.

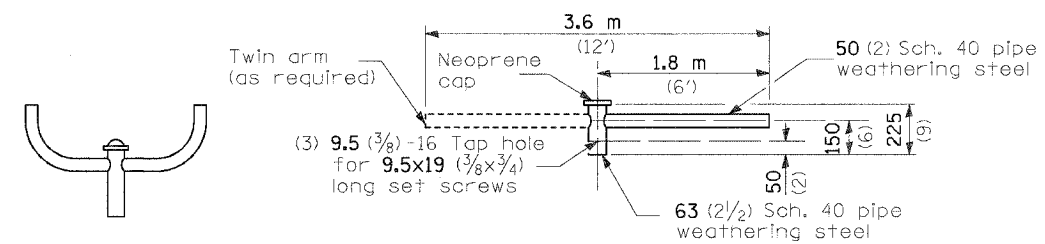

TWIN TENON TENON MOUNT BRACKET ARM

NOTE: Single or twin arm assembly shall be tilted 3° above horizontal.

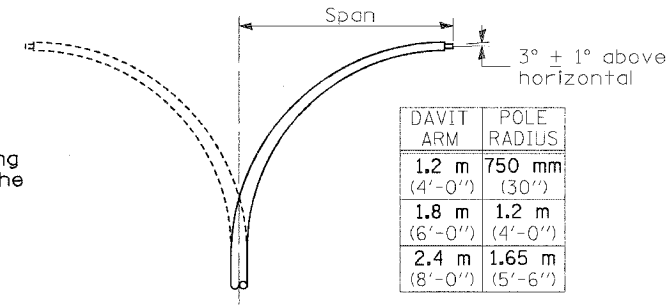

DAVIT ARM (and or)
 DAVIT ARM-TWIN

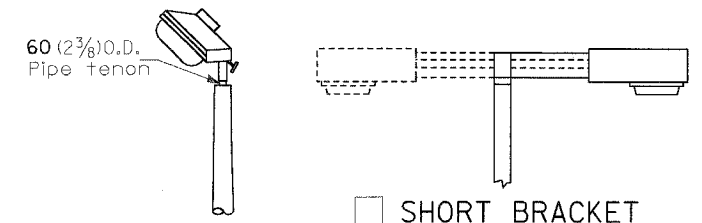

SHORT BRACKET
 SHORT BRACKET - TWIN

TENON

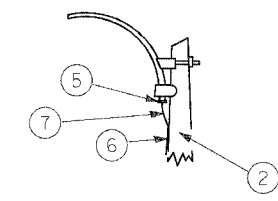

MAST ARM

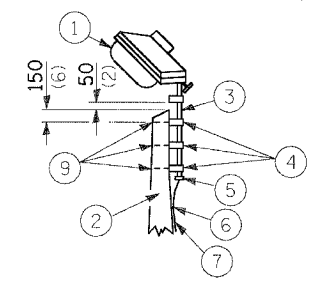

TENON

- ① Luminaire
- ② Wood pole, class 3 or better
- ③ 63 (2 1/2) Galv. steel conduit
- ④ Single offset pole band
- ⑤ Conduit bushing
- ⑥ Cable clamps on 600 (24) centers
- ⑦ 2/c #12 Type use cable
- ⑧ 25 (1) Galv. steel conduit 3.0 m (10') in length
- ⑨ 16 (5/8) Ø hot dipped galvanized bolt with flat washer & locknut (3 req'd)
- ⑩ Conduit clamps on 900 (36) centers
- ⑪ Unit duct
- ⑫ Threaded reducer
- ⑬ "C" Condulet, threaded
- ⑭ 40 (1 1/2) Galv. steel conduit for 1 unit duct or 75 (3) galv. steel conduit for 2 or 3 unit ducts.

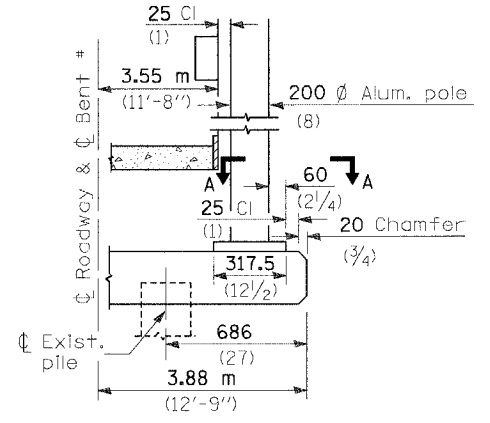

BENT # (Looking)

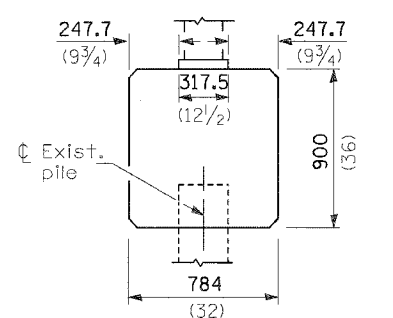

BRIDGE PIER MOUNT

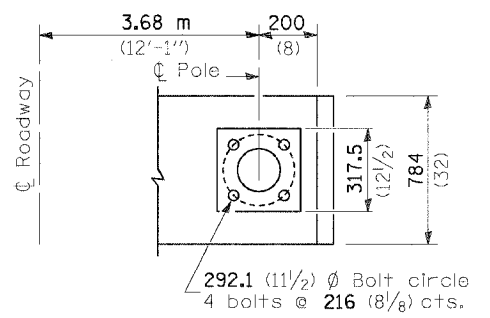

SECTION A-A

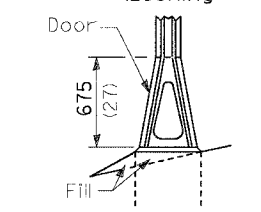

STAINLESS STEEL FLAIR BASE

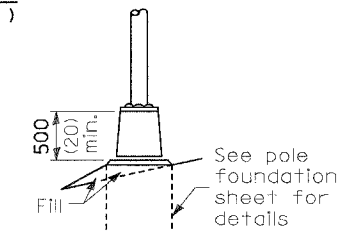

TRANSFORMER BASE

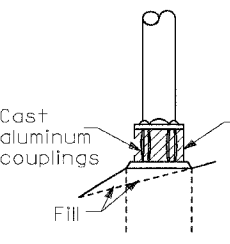

BREAKAWAY COUPLING

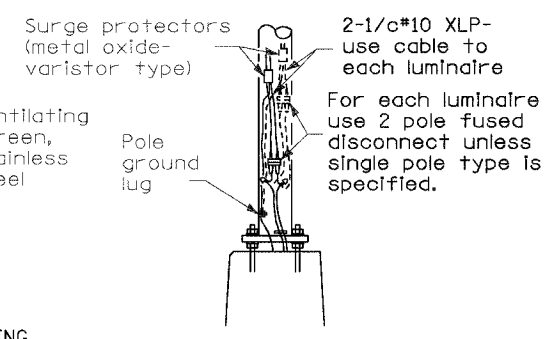

ANCHOR

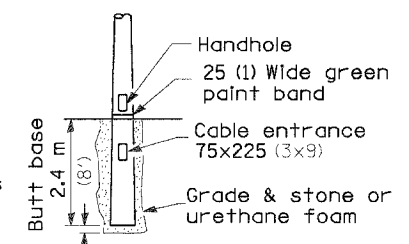

BUTT BASE

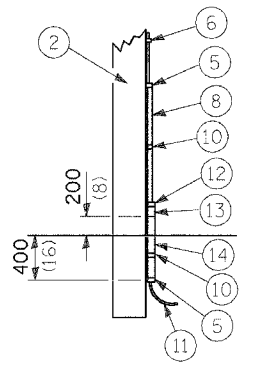

POLE, WOOD

POLE LENGTH	DEPTH IN GROUND
19.8 m (65')	3.6 m (12')
18.0 m (60')	3.0 m (10')
16.8 m (55')	2.7 m (9')
16.0 m (50')	2.4 m (8')
13.7 m (45')	2.1 m (7')
12.0 m (40')	2.0 m (6.5')
10.7 m (35')	1.8 m (6')
9.0 m (30')	1.7 m (5.5')

FRANGIBLE

METAL OR CONCRETE

Details for underground distribution if required

POLE STANDARDS

REVISIONS	
NAME	DATE

ILLINOIS DEPARTMENT OF TRANSPORTATION
LIGHTING PLAN -
LIGHTING DETAILS 3 OF 5
FAP 322 (US 51)
SECTION 11-1
CHRISTIAN COUNTY

SCALE: NONE DRAWN BY: IDOT
DATE: CHECKED BY:



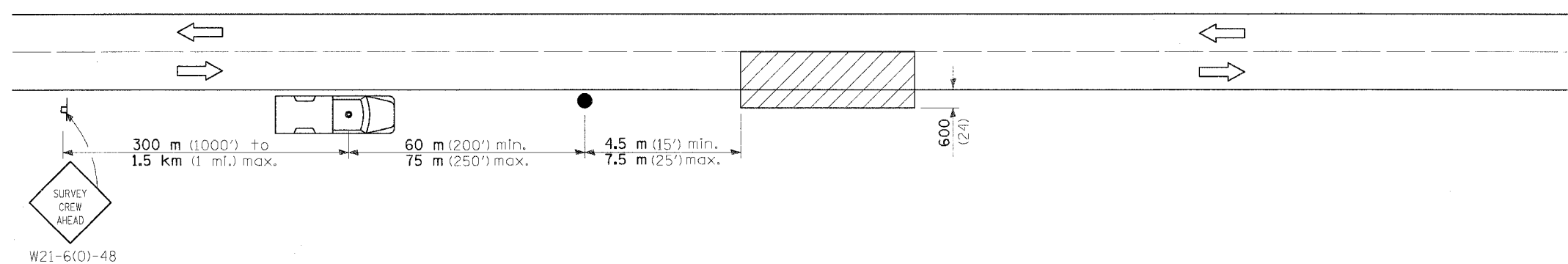

3/29/2005

F.A.P. RTE.	SECTION	COUNTY	TOTAL SHEETS	SHEET NO.
322	11-10	CHRISTIAN	310	130
STA.		TO STA.		
FED. ROAD DIST. NO.		ILLINOIS FED. AID PROJECT		

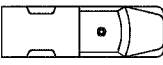

FLAGGER SHALL BE EQUIPPED WITH AND REQUIRED TO USE A HIGH INTENSITY, OR HIGH PERFORMANCE " STOP - SLOW " TRAFFIC CONTROL PADDLE. FLAGGER AND LIGHTING INSPECTOR SHALL BE REQUIRED TO WEAR A HIGH VISIBILITY, REFLECTIVE ORANGE VEST AND EITHER A HARD HAT OR AN ORANGE CAP.

SYMBOLS

-  Work area
-  Sign on portable or permanent support
-  Truck with flashing amber light and dual emergency flashers
-  Flagger with traffic control sign

TYPICAL APPLICATIONS
Utility operations

DETAIL FOR NIGHTTIME LIGHTING INSPECTION

REVISIONS	
NAME	DATE

ILLINOIS DEPARTMENT OF TRANSPORTATION
LIGHTING PLAN -
LIGHTING DETAILS 5 OF 5
FAP 322 (US 51)
SECTION 11-1
CHRISTIAN COUNTY

SCALE: NONE
DATE: DRAWN BY: IDOT
CHECKED BY:

3/29/2005

F.A.P. RTE.	SECTION	COUNTY	TOTAL SHEETS	SHEET NO.
322	11-10	CHRISTIAN	310	131
STA.		TO STA.		
FED. ROAD DIST. NO.		ILLINOIS FED. AID PROJECT		

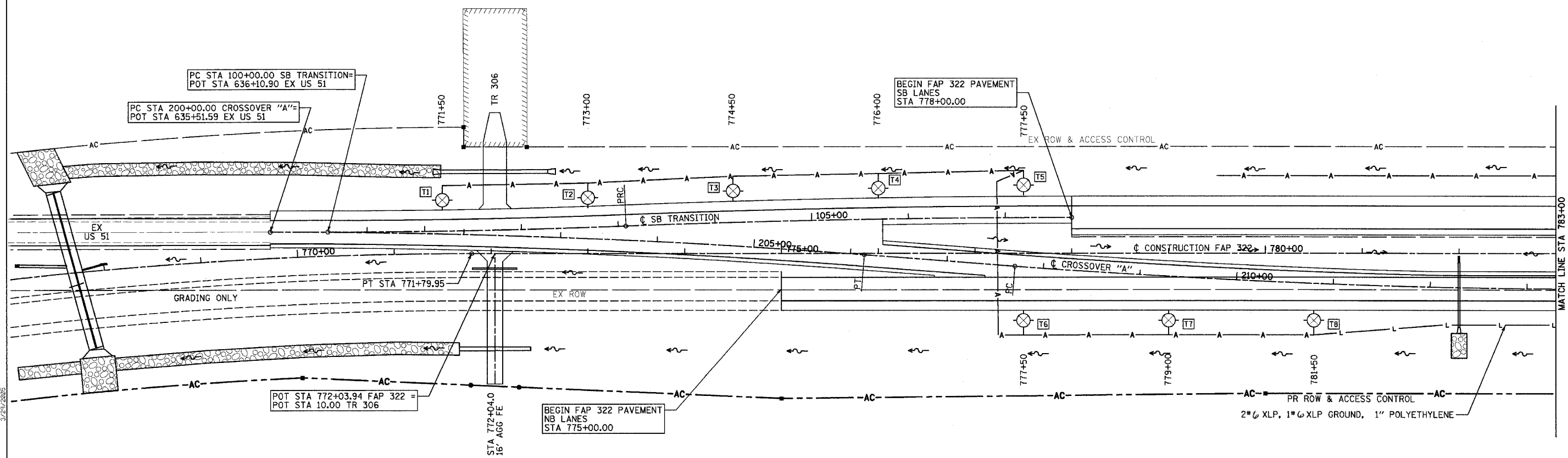

3/29/2005

D:\BIF\back\0832\concrete\plan\131\p82r.asd

NOTES:

1. ALL POLES TO BE SET BACK 30' FROM EDGE OF PAVEMENT UNLESS THIS DISTANCE FALLS IN THE FLOW LINE OF THE DITCH. IN THAT CASE MOVE FURTHER BACK OUT OF THE FLOW LINE OR AS DIRECTED BY THE ENGINEER.
2. SEAL UNIT DUCT AT TOP OF POLE T8 TO KEEP MOISTURE OUT.
3. WHERE UNDERGROUND CABLE IS SPLICED TO AERIAL, KEEP ALUMINUM OVER COPPER.
4. PROTECT THE VERTICAL RUN OF UNIT DUCT WITH STEEL U-GUARD.

LEGEND

- CONTROL INSTALLATION PHOTOCELL RELAY 120/240 VOLT SERVICE POLE MOUNT
- WOOD LIGHTING POLE, 50' CLASS 3 WITH 250 WATT HPS MULTI MOUNT LUMINAIRE.
- LIGHT POLE STEEL, 45' MOUNTING HEIGHT WITH 250 WATT HPS MULTI-MOUNT LUMINAIRE
- LIGHT POLE STEEL, TWIN, 45' MOUNTING HEIGHT WITH 250 WATT HPS MULTI-MOUNT LUMINAIRE
- UNIT DUCT (AS NOTED)
- AERIAL CABLE, 2-1/C#4, ALUMINUM WITH MESSENGER WIRE
- 2" GALVANIZED STEEL CONDUIT (IMC) PUSHED (LENGTH AS NOTED)

PERFORMANCE REQUIREMENTS

NOTE: These performance requirements shall be the minimum acceptable standards of photometric performance for the luminaire.

ILLUMINATION:	Average Horizontal Illumination, (Eave)	9.0 Lux
	Uniformity Ratio, (Eave/Emin)	3.0
LUMINANCE:	Average Luminance, (Lave)	0.6 Cd/sq m
	Uniformity Ratios: (Lmax/Lmin)	3.0
	(Lmax/Lmin)	6.0
	Maximum Veiling Luminance Ratio: (Lv/Lave)	0.3

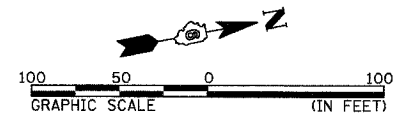
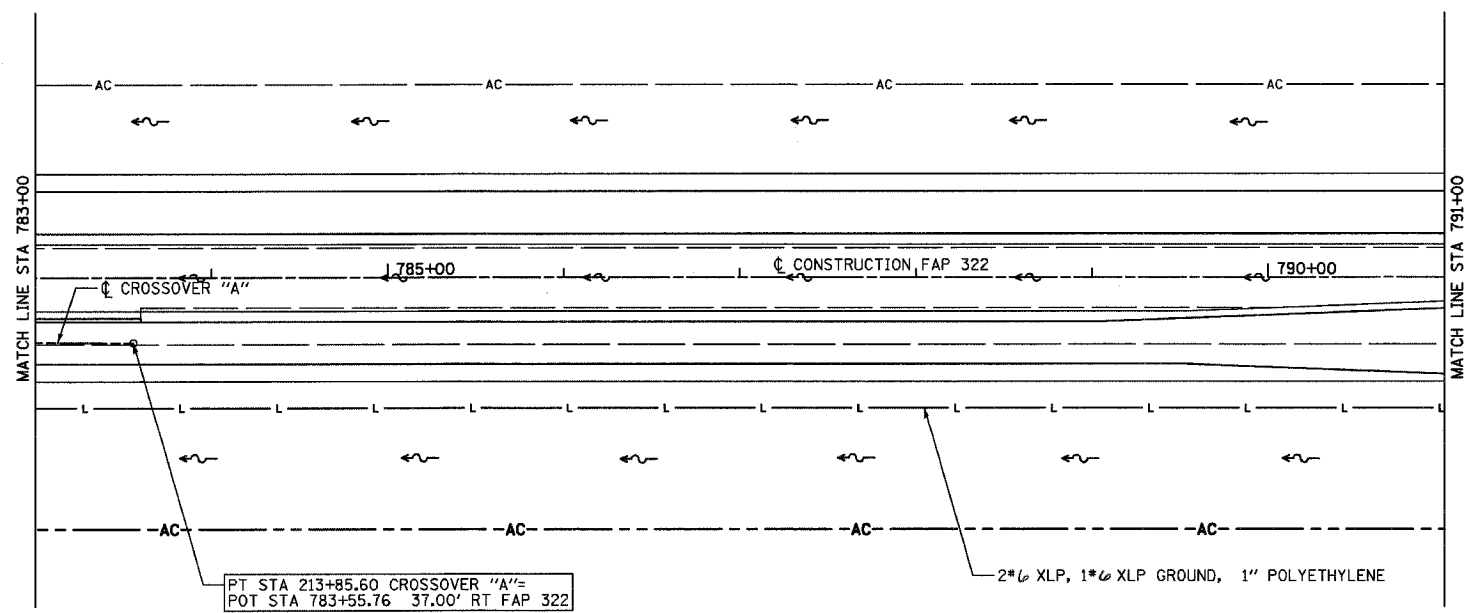

REVISIONS	
NAME	DATE

ILLINOIS DEPARTMENT OF TRANSPORTATION
LIGHTING PLAN -
SB TRANSITION & CROSSOVER "A"
FAP 322 (US 51)
SECTION 11-1
CHRISTIAN COUNTY
 SCALE: 1"=50'
 DATE: 3/18/05
 DRAWN BY: BDJ
 CHECKED BY: SEB

Rev.

F.A.P. RTE.	SECTION	COUNTY	TOTAL SHEETS	SHEET NO.
322	11-10	CHRISTIAN	310	132
STA.		TO STA.		
FED. ROAD DIST. NO.	ILLINOIS	FED. AID PROJECT		

LEGEND

- CONTROL INSTALLATION PHOTOCELL RELAY 120/240 VOLT SERVICE POLE MOUNT
- LIGHT POLE STEEL, 45' MOUNTING HEIGHT WITH 250 WATT HPS MULTI-MOUNT LUMINAIRE
- LIGHT POLE STEEL, TWIN, 45' MOUNTING HEIGHT WITH 250 WATT HPS MULTI-MOUNT LUMINAIRE
- UNIT DUCT (AS NOTED)
- 2" GALVANIZED STEEL CONDUIT (IMC) PUSHED (LENGTH AS NOTED)

NOTES:

1. UPON REMOVAL OF TEMPORARY LIGHTING, ALL LUMINARIES TO BECOME PROPERTY OF THE STATE AS PER SECTION 841.
2. ALL POLES TO BE SET BACK 30' FROM EDGE OF PAVEMENT UNLESS THIS DISTANCE FALLS IN THE FLOW LINE OF THE DITCH. IN THAT CASE MOVE FURTHER BACK OUT OF THE FLOW LINE OR AS DIRECTED BY THE ENGINEER.
3. EXACT LOCATION OF PHOTOCELL CONTROLLER TO BE DETERMINED BY THE ENGINEER AS LONG AS IT IS WITHIN 150' OF THE SERVICE.
4. CONDUIT PUSHED CAN BE DELETED IF UNIT DUCT CAN BE TRENCHED IN BEFORE PAVEMENT IS CONSTRUCTED.
5. LOCATE THE POINT OF SERVICE IN THE SE QUADRANT OF THE INTERSECTION IF POSSIBLE TO KEEP VOLTAGE DROP WITHIN RANGE.

PERFORMANCE REQUIREMENTS	
NOTE: These performance requirements shall be the minimum acceptable standards of photometric performance for the luminaire.	
ILLUMINATION:	Average Horizontal Illumination, (Eave) <u>9.0 Lux</u>
	Uniformity Ratio, (Eave/Emin) <u>3.0</u>
LUMINANCE:	Average Luminance, (Lave) <u>0.6 Cd/sq.m</u>
	Uniformity Ratios: (Lave/Lmin) <u>3.5</u>
	(Lmax/Lmin) <u>6.0</u>
	Maximum Veiling Luminance Ratio: (Lv/Lave) <u>0.3</u>

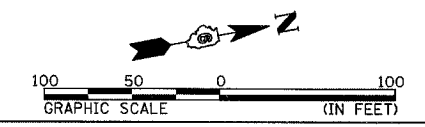

REVISIONS	
NAME	DATE

ILLINOIS DEPARTMENT OF TRANSPORTATION
 LIGHTING PLAN -
 TR 185 INTERSECTION
 FAP 322 (US 51)
 SECTION 11-1
 CHRISTIAN COUNTY

SCALE: 1"=50'
 DATE: 3/18/05

DRAWN BY: BDJ
 CHECKED BY: SEB

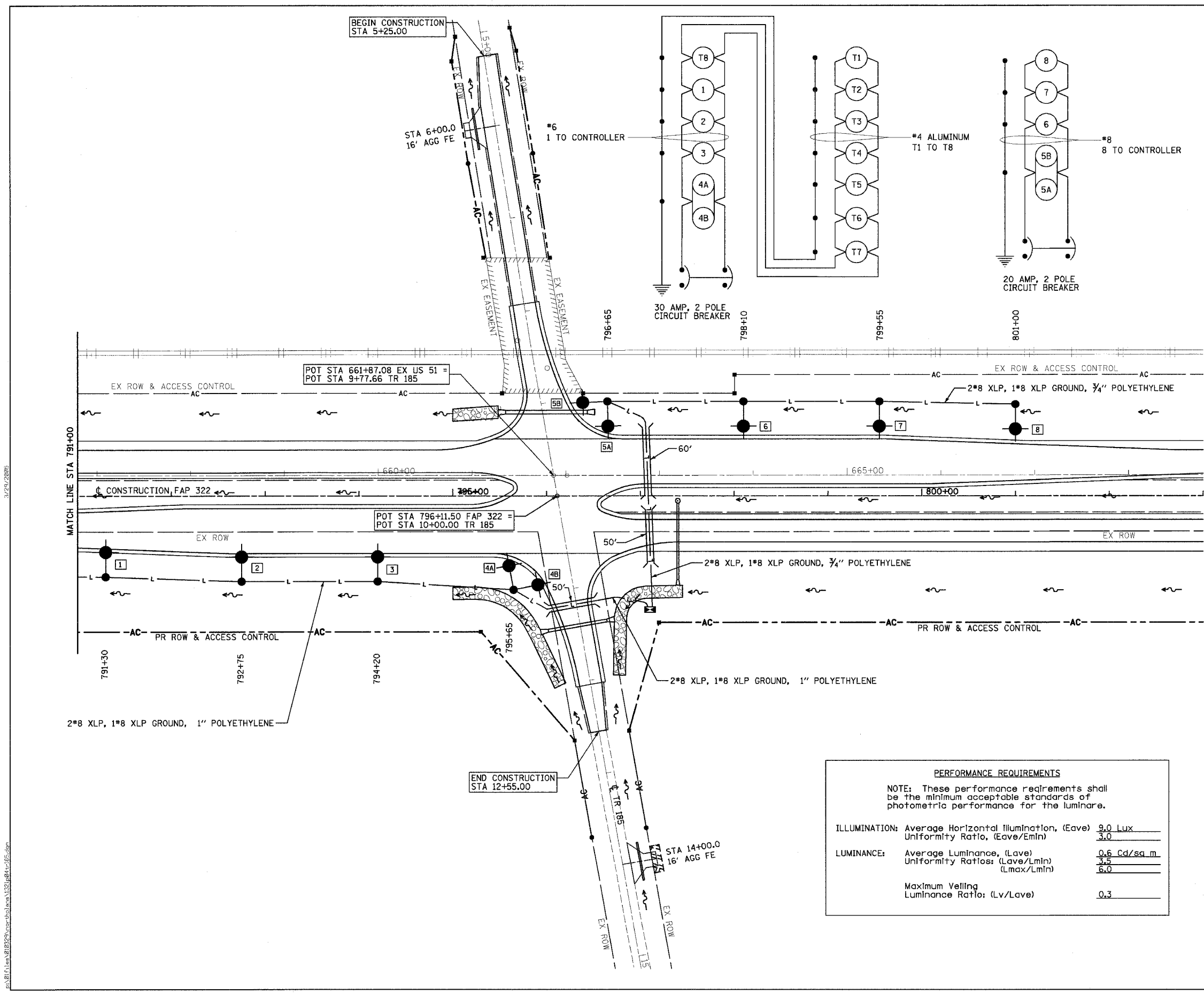

3/29/2005

F.A.P. RYE.	SECTION	COUNTY	TOTAL SHEETS	SHEET NO.
322	11-10	CHRISTIAN	310	133
STA.		TO STA.		
FED. ROAD DIST. NO.		ILLINOIS FED. AID PROJECT		

PERFORMANCE REQUIREMENTS

NOTE: These performance requirements shall be the minimum acceptable standards of photometric performance for the luminaire.

ILLUMINATION: Average Horizontal Illumination, (Eave) 3.0 Lux
 Uniformity Ratio, (Eave/Emin) 3.0

LUMINANCE: Average Luminance, (Lave) 0.6 Cd/sq m
 Uniformity Ratios: (Lave/Lmin) 3.5
 (Lmax/Lmin) 6.0

Maximum Veiling Luminance Ratio: (Lv/Lave) 0.3

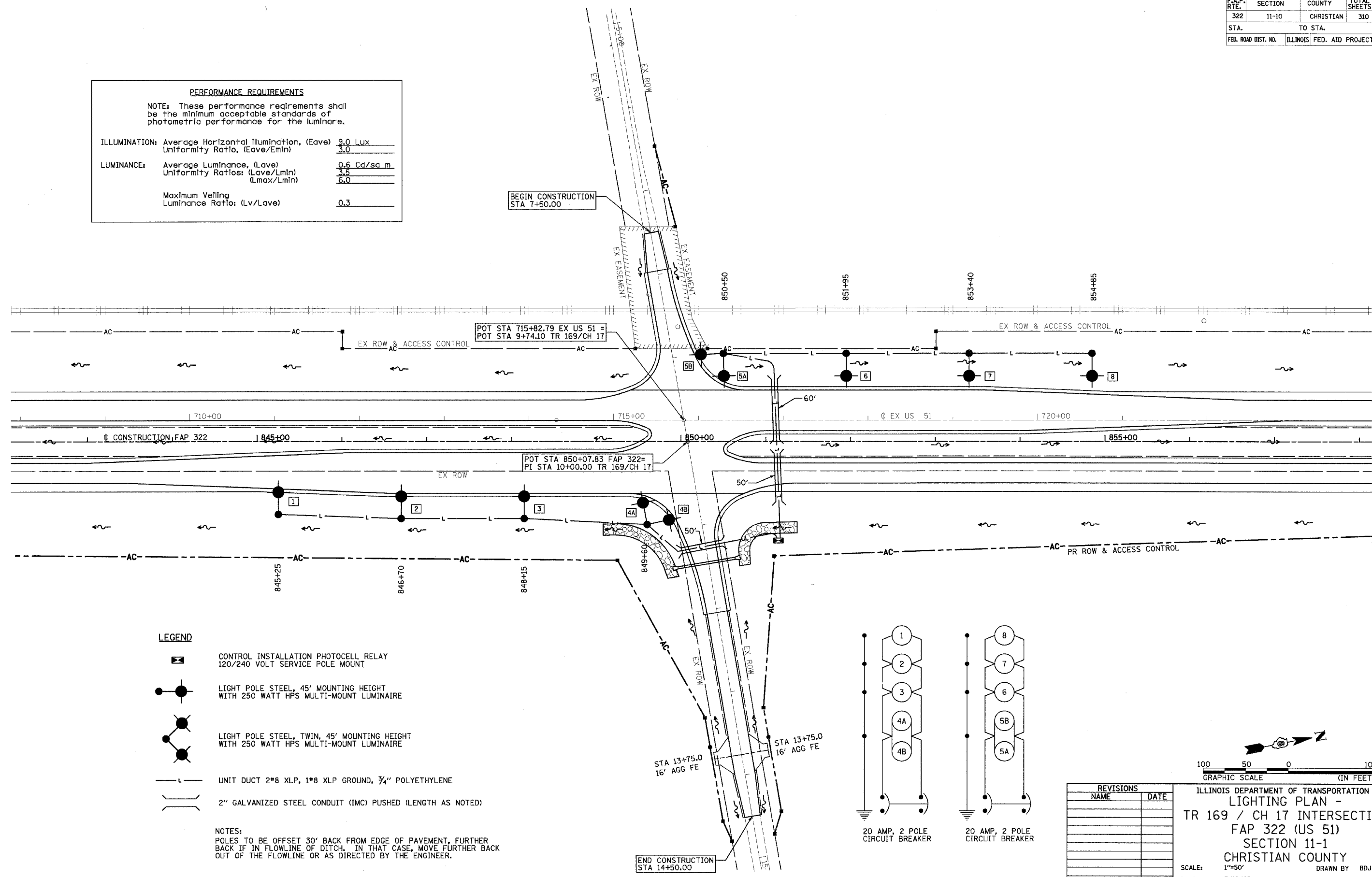

- LEGEND**
- CONTROL INSTALLATION PHOTOCELL RELAY
120/240 VOLT SERVICE POLE MOUNT
 - LIGHT POLE STEEL, 45' MOUNTING HEIGHT
WITH 250 WATT HPS MULTI-MOUNT LUMINAIRE
 - LIGHT POLE STEEL, TWIN, 45' MOUNTING HEIGHT
WITH 250 WATT HPS MULTI-MOUNT LUMINAIRE
 - UNIT DUCT 2*8 XLP, 1*8 XLP GROUND, 3/4" POLYETHYLENE
 - 2" GALVANIZED STEEL CONDUIT (IMC) PUSHED (LENGTH AS NOTED)

NOTES:
 POLES TO BE OFFSET 30' BACK FROM EDGE OF PAVEMENT, FURTHER BACK IF IN FLOWLINE OF DITCH. IN THAT CASE, MOVE FURTHER BACK OUT OF THE FLOWLINE OR AS DIRECTED BY THE ENGINEER.

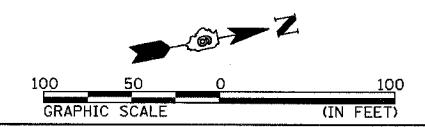
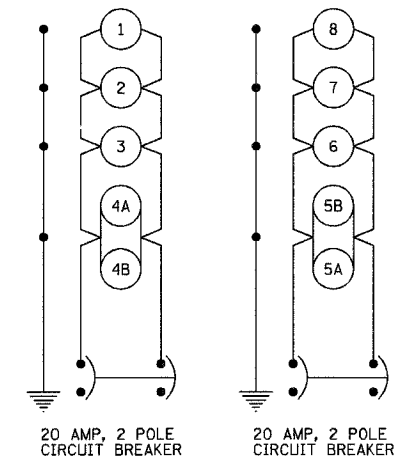

REVISIONS	
NAME	DATE

ILLINOIS DEPARTMENT OF TRANSPORTATION
 LIGHTING PLAN -
 TR 169 / CH 17 INTERSECTION
 FAP 322 (US 51)
 SECTION 11-1
 CHRISTIAN COUNTY

SCALE: 1"=50'
 DATE: 3/18/05

DRAWN BY: BDJ
 CHECKED BY: SEB

3/29/2005

F.A.P. RTE.	SECTION	COUNTY	TOTAL SHEETS	SHEET NO.
322	11-10	CHRISTIAN	310	135
STA.		TO STA.		
FED. ROAD DIST. NO.		ILLINOIS FED. AID PROJECT		

LEGEND

(FOR THE STORM WATER POLLUTION PREVENTION PLAN SHEETS)

ITEM	SYMBOL
AGGREGATE (EROSION CONTROL) - ESTIMATED QUANTITY [STONE DUMPED RIPRAP DITCH CHECKS (Height = 2'-0")]	
TEMPORARY DITCH CHECKS/INLET PIPE PROTECTION (I&PP) (ROLLED EXCELSIOR DITCH CHECKS IN MEDIAN DITCHES, AGGREGATE DITCH CHECKS (2' HEIGHT) AT ALL OTHER LOCATIONS)	or
PERIMETER EROSION BARRIER	
EARTH EXCAVATION FOR EROSION CONTROL (SEDIMENT BASINS)	
PRESERVE EXISTING TREES, WOODLANDS, AND UNDERSTORY (OUTSIDE CONSTRUCTION LIMITS)	
ITEM PLACED AT BEGINNING OF CONSTRUCTION (Requirement)	* *
ITEM PLACED AS DIRECTED BY ENGINEER (When required by situation)	
DIRECTION OF OVERLAND FLOW	
EXCELSIOR / EROSION CONTROL BLANKET	
ITEM PLACED DURING STAGE 1 CONSTRUCTION	

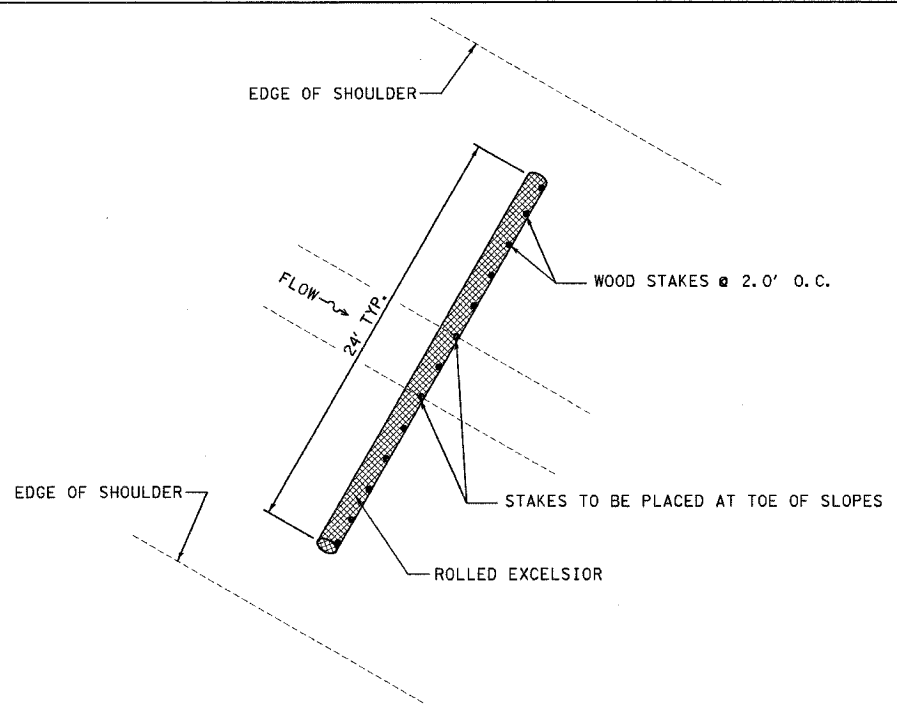

PLAN VIEW

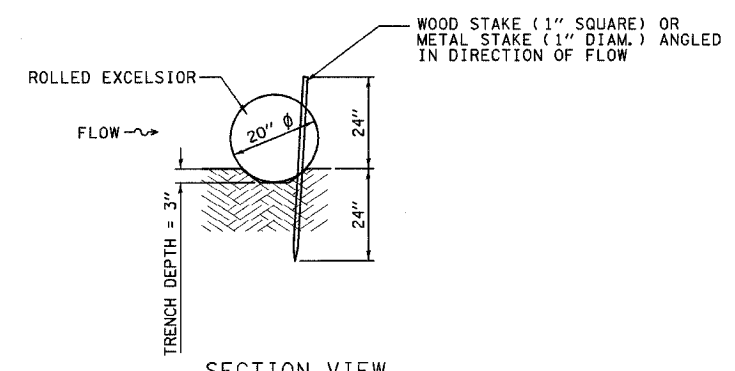

SECTION VIEW

ROLLED EXCELSIOR DITCH CHECK
(TYPICAL)

SEE STANDARD 280001-02
FOR EROSION CONTROL
DETAILS NOT SHOWN.

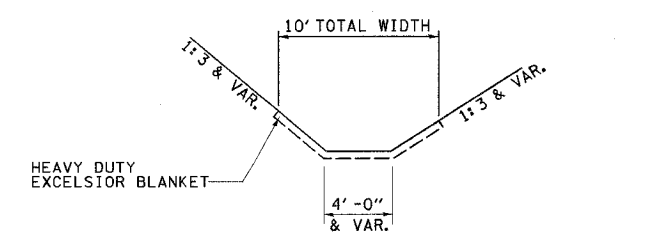

HEAVY DUTY EXCELSIOR BLANKET LIMITS
(TYPICAL)

GENERAL NOTES:

All items shall be constructed as shown on this sheet, on Standard 280001, and as directed by the Engineer.

Mulch shall be method 2, unless otherwise noted.

Temporary ditch checks and inlet pipe protection shall be placed with aggregate ditch checks in the outside ditches and rolled excelsior in the median ditches. Hay bales will not be allowed. No additional compensation will be allowed for the use of the aggregate and / or the rolled excelsior.

REVISIONS	
NAME	DATE

ILLINOIS DEPARTMENT OF TRANSPORTATION
STORM WATER POLLUTION PREVENTION PLAN
 FAP 322 (US 51)
 SECTION 11-1
 CHRISTIAN COUNTY

SCALE: NONE
 DATE: 3/21/05

DRAWN BY: SEB
 CHECKED BY: EBB

3/21/2005

6/11/05 10:02:29 AM C:\p1\plan\11\11eap01135.dwg

F.A.P. RTE.	SECTION	COUNTY	TOTAL SHEETS	SHEET NO.
322	11-10	CHRISTIAN	310	136
STA.		TO STA.		
FED. ROAD DIST. NO.	ILLINOIS	FED. AID PROJECT		

STORM WATER POLLUTION PREVENTION PLAN

Route: FAP 322 Marked: US 51
 Section: 11-10 Project No.: NA
 County: CHRISTIAN Contract No. 92677

This plan has been prepared to comply with the provision of the NPDES Permit Number ILR10 _____ issued by the Illinois Environmental Protection Agency for storm water discharges from construction site activities.

I certify under penalty of law that this document and all attachments were prepared under my direction or supervision in accordance with a system designed to assure that qualified personnel gathered and evaluated the information submitted. Based on my inquiry of the person or persons who manage the system, or those persons directly responsible for gathering the information submitted, is, to the best of my knowledge and belief, true, accurate, and complete. I am aware that there are significant penalties for submitting false information, including the possibility of fine and imprisonment for knowing violations.

 (Signature)

 (Date)

 (Title)

Note: The above boxed in area will be filled out by IDOT - Construction after the award of the contract to obtain the required NPDES permit.

The following plan was established and included in these plans to direct the Contractor in the placement of temporary erosion control systems and to provide a storm water pollution prevention plan for compliance under NPDES. The Contractor shall abide to all requirements within this plan as part of the contract.

The purpose of this plan is to prevent / minimize siltation within the construction zone and to eliminate sediments from entering and leaving the construction zone by utilizing proper temporary erosion control systems and providing ground cover within a reasonable time.

Certain items, as shown in this plan and referenced by the legend, shall be placed by the Contractor at the beginning of construction. Other items shall be placed by the Contractor as directed by the Engineer on a case by case situation resulting from the Contractor's sequence of activities, time of the year, and expected weather conditions.

The Contractor shall place permanent erosion control systems and seeding within a reasonable amount of time; therefore, reducing the amount of area being open to the possibility of erosion and reducing the amount of temporary erosion control systems and temporary seeding. The Resident Engineer will determine if temporary erosion control systems shown in the plan can be deleted, the size of the proposed ditch checks, the proper method of installation, and if any additional temporary erosion control systems shall be added which are not included in this plan. The Contractor shall perform all work as directed by the Engineer and as shown in special details and in Standard 280001 of the plans.

The special provisions Temporary Seeding, Temporary Erosion Control Seeding, and Temporary Erosion Control additionally supplement this plan.

All disturbed areas having high potential for erosion, as determined by the Engineer, shall be temporarily seeded or permanently seeded by October 1, and shall not be reopened until after the winter shutdown period.

SITE DESCRIPTION

Description of Construction Activity:

1. The proposed project consists of new construction of a new four-lane expressway from 1 mile south of Moweaqua to the intersection of US 51 and County Highway 6 east of Assumption in Christian County.
2. This contract involves 3.86 miles of grading & paving and 1.71 miles of grading only of the four lane expressway.
3. A double 7' by 6' box culvert will be constructed over a tributary to the Big George Branch. Several additional small drainage structures will be constructed through the limits of the project.

Description of Intended Sequence of Major Construction Activities Which Will Disturb Earth and Lead to Possible Erosion for Major Portions of the Construction Site:

1. Excavation will be completed to grade out for proposed roadway ditches and waterways, and to lower the existing ground elevation to meet the proposed roadway grade/vertical alignment.
2. Embankment will be completed in fill areas to raise the existing ground elevation to meet the proposed roadway grade/vertical alignment.
3. Drainage structures will be installed before and/or during the construction of the excavation and embankment to allow proper drainage across the proposed four lane facility.
4. Placement, maintenance, removal and proper clean-up of temporary erosion control, such as erosion control fence, hay or straw bale ditch checks, riprap ditch checks, sediment basins, temporary seeding, etc.
5. Placement of permanent erosion control, such as riprap ditch lining, riprap stilling basins, riprap dry dams, excelsior blanket, seeding, etc.
6. Final grading, paving and other miscellaneous items.
7. Stage construction of the above items will be required to maintain traffic as discussed previously herein.

Area of Construction Site:

The total drainage area entering and including the construction site is estimated to be 1970 acres (3.1 square miles) in which 160 acres will be disturbed by excavation, grading or other activities.

Other Reports, Studies and Plans which Aid in the Development of this Storm Water Pollution Prevention Plan as Referenced Documents:

1. Estimated run-off coefficients are contained in the project drainage study which were utilized for proposed placement of the temporary erosion control systems.
2. Information on the soils within the site was obtained from field reviews which were utilized for proposed placement of the temporary erosion control systems.
3. Site maps indicating drainage patterns and approximate slopes were contained in the project design report, USGS drainage maps, project drainage study, and project plan documents were all utilized for proposed placement of the temporary erosion control systems.

Drainage Tributaries Receiving Water from this Construction Site:

1. Big George Branch of the Sagamon River
2. Flat Branch of the Sagamon River
3. Minor tributaries of the above

REVISIONS	
NAME	DATE
DATE - SEB	4/4/05

ILLINOIS DEPARTMENT OF TRANSPORTATION
STORM WATER POLLUTION PREVENTION PLAN
 FAP 322 (US 51)
 SECTION 11-1
 CHRISTIAN COUNTY

SCALE: NONE DRAWN BY SEB
 DATE 3/21/05 CHECKED BY EBB

4/5/2005

F.A.P. RTE.	SECTION	COUNTY	TOTAL SHEETS	SHEET NO.
322	11-10	CHRISTIAN	310	137
STA.		TO STA.		
FED. ROAD DIST. NO.		ILLINOIS FED. AID PROJECT		

CONTROLS - EROSION CONTROLS AND SEDIMENT CONTROLS

Description of Stabilization Practices at the Beginning of Construction:

- The area between the existing and proposed right-of-way/temporary easement boundaries and limits of the project will be improved and managed for the purposes of controlling erosion within the area, reducing water flow by temporary diversion and minimizing siltation into the construction zone, and establishing vegetative cover which will become permanent vegetation and act as an erosion barrier. Work at the beginning of construction will consist of the following:
 - Areas of existing vegetation (woods and grasslands) outside the proposed construction slope limits shall be identified for preserving and shall be protected from mowing, brush cutting, tree removal and other activities which would be detrimental to their maintenance and development.
 - Dead, diseased, or unsuitable vegetation within the site shall be removed as directed by the Engineer, along with required tree removal.
 - As soon as reasonable access is available (such as trees cleared) to all locations where water drains away from the project, sediment basins, riprap ditch checks, temporary ditch checks, and/or erosion control fence shall be installed as called out in this plan and directed by the Engineer.
 - Bare and sparsely vegetated ground in highly erodible areas as determined by the Engineer shall be temporarily seeded at the beginning of construction where no construction activities are immediately expected as stated in the special provision "Temporary Erosion Control Seeding".
 - Immediately after tree removal is completed in certain areas which are highly erodible areas as determined by the Engineer, the areas shall be temporarily seeded where no construction activities are immediately expected as stated in the special provision "Temporary Erosion Control Seeding".
 - At locations where a significant amount of water drains into the construction zone from outside areas (adjacent landowners), erosion control fence, temporary ditch checks, or riprap ditch checks will be utilized to locally divert water, reduce flow rates, and collect outside siltation inside the right-of-way line. Erosion control items will not be allowed to be installed to cause flooding to upstream private property which could cause crop damages or other undesirable conditions.
- Establishment of these temporary erosion control measures will have additional benefits to the project. Desirable grass seed will become established in these areas and will spread seeds onto the construction site until permanent seeding/mowing and overseeding can be complete.
- A third benefit of these filter areas is that they will begin to provide a screen and buffer. They will help protect the construction site from winds and excess sun and mitigate construction noise and dust.

Description of Stabilization Practices During Construction:

- During roadway construction, areas outside the construction slope limits as outlined previously herein shall be protected from damaging effects of construction. The Contractor shall not use this area for staging (except as designated on the plans or directed by the Engineer), parking of vehicles or construction equipment, storage of materials, or other construction related activities.
 - Within the construction zone, critical areas which have high flows of water as determined by the Engineer shall remain undisturbed until full scale construction is underway to prevent unnecessary soil erosion.
 - Top soil and earth stockpiles shall be temporarily seeded if they are to remain unused for more than fourteen days.
 - As the Contractor constructs a portion of roadway in a fill section, he/she shall follow the following steps as directed by the Engineer:
 - Place temporary erosion control systems at locations where water leaves and enters the construction zone
 - Temporarily seed highly erodible areas outside the construction slope limits
 - Construct roadside ditches and provide temporary erosion control systems
 - Temporarily divert water around proposed culvert locations
 - Build necessary embankment at culvert locations and then excavate and place culvert
 - Continue building up the embankment to the proposed grade while at the same time place permanent erosion control such as riprap ditch lining and conduct final shaping to the slopes
 - The Contractor shall immediately follow major earth moving operations with final grading equipment. After the major earth spread operation has moved to a new location, final grading shall be completed within fourteen days. If grading is not completed within fourteen days, all major earth moving operations will be stopped, as directed by the Engineer, until disturbed areas are final graded and seeded.
 - Excavated areas and embankments shall be permanently seeded when final graded. If not, they shall be temporarily seeded as stated in the special provision "Temporary Erosion Control Seeding".

- Construction equipment shall be stored and fueled only at designated locations. All necessary measures shall be taken to contain any fuel or pollution run-off in compliance with EPA water quality regulations. Leaking equipment or supplies shall be immediately repaired or removed from the site.
- The Resident Engineer shall inspect the project daily during activities and weekly or after large rains during the winter shutdown period. The project shall additionally be inspected by the Construction Field Engineer on a bi-weekly basis to determine that erosion control efforts are in place and effective and if other control work is necessary.
- Sediment collected during construction by the various temporary erosion control systems shall be disposed of on the site on a regular basis as directed by the Engineer. The cost of this maintenance will be paid for in accordance with Article 109.04 of the Standard Specifications.
- The temporary erosion control systems shall be removed as directed by the Engineer after use is no longer needed or no longer functioning. The costs of this removal shall be included in the unit bid price for the temporary erosion control system. No additional compensation will be allowed.

Description of Structural Practices After Final Grading:

- Temporary erosion control systems shall be left in place with proper maintenance until permanent erosion control is in place and working properly and all proposed turf areas seeded and established with a proper stand.
- Once permanent erosion control systems as proposed in the plans are functional and established, temporary items shall be removed, cleaned up, and disturbed turf reseeded. Temporary riprap ditch checks will be allowed to remain in place where approved by the Engineer.

Maintenance after Construction:

- Construction is complete after acceptance is received at the final inspection.
- Areas will be inspected on a regular basis by IDOT District 6 Bureau of Operations.
- Maintenance crews will perform regular mowings to aid in keeping weeds down and establishing a good roadside seed stand.
- Maintenance crews will also aid in any ditch lining maintenance or in any drainage problems.
- All maintenance will be conducted at times when weather conditions will not cause site damage.

DOCUMENTATION

- A report summarizing the scope of the inspection, name(s) and qualifications of personnel making the inspection, date(s) of the inspection, major observations relating to the implementation of this storm water pollution prevention plan, and actions taken in accordance with Section 4.b. shall be made and retained as part of the plan for at least three years after the date of inspection. The report shall be signed in accordance with part VI.G of the general permit.
- If any violation of the provisions of this plan is identified during the conduct of the construction work covered by this plan, the Resident Engineer or Resident Technician shall complete and file an "Incident of Noncompliance (ION)" report for the identified violation. The Resident Engineer or Resident Technician shall use forms provided by the Illinois Environmental Protection Agency and shall include specific information on the noncompliance, actions which were taken to prevent any further causes of noncompliance, and a statement detailing any environmental impact which may have resulted from the noncompliance. All reports of noncompliance shall be signed by a responsible authority in accordance with Part VI.G. of the general permit. The report of noncompliance shall be mailed to the following address:

Illinois Environmental Protection Agency
 Division of Water Pollution Control
 2200 Churchill Road, P.O. Box 19276
 Springfield, IL 62794-9276
 Attn: Compliance Assurance Section

REVISIONS	
NAME	DATE

ILLINOIS DEPARTMENT OF TRANSPORTATION
 STORM WATER POLLUTION
 PREVENTION PLAN
 FAP 322 (US 51)
 SECTION 11-1
 CHRISTIAN COUNTY

SCALE: NONE DRAWN BY SEB
 DATE 3/21/05 CHECKED BY EBB

3/21/2005

\\s01\lans\010224\user\plans\137\222\222.dwg

NW 1/4 SEC 1, T12N, R1E, 3RD PM

SW 1/4 SEC 36, T13N, R1E, 3RD PM

F.A.P. RTE.	SECTION	COUNTY	TOTAL SHEETS	SHEET NO.
322	11-10	CHRISTIAN	310	139
STA.		TO STA.		
FED. ROAD DIST. NO.	ILLINOIS	FED. AID PROJECT		

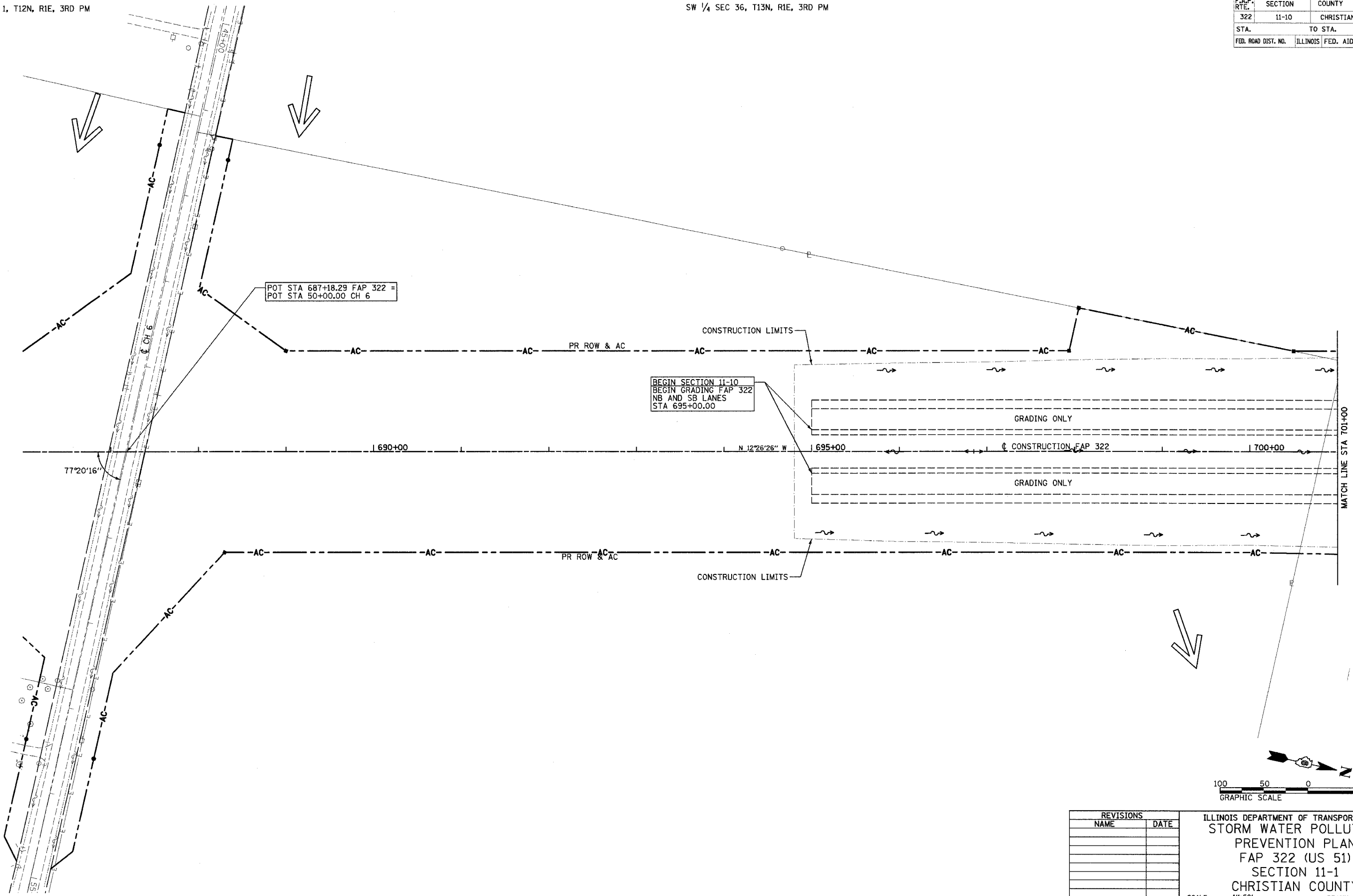

3/25/2005

g:\2111\1105\1105225\1105225.dwg

SW 1/4 SEC 36, T13N, R1E, 3RD PM

REVISIONS	
NAME	DATE

ILLINOIS DEPARTMENT OF TRANSPORTATION
 STORM WATER POLLUTION
 PREVENTION PLAN
 FAP 322 (US 51)
 SECTION 11-1
 CHRISTIAN COUNTY

SCALE: 1"=50'
 DATE: 3/18/05

DRAWN BY: BDJ
 CHECKED BY: SEB

FAP 322 (US 51) STA 686+00 TO STA 701+00

F.A.P. RTE.	SECTION	COUNTY	TOTAL SHEETS	SHEET NO.
322	11-10	CHRISTIAN	310	140
STA.		TO STA.		
FED. ROAD DIST. NO.	ILLINOIS	FED. AID PROJECT		

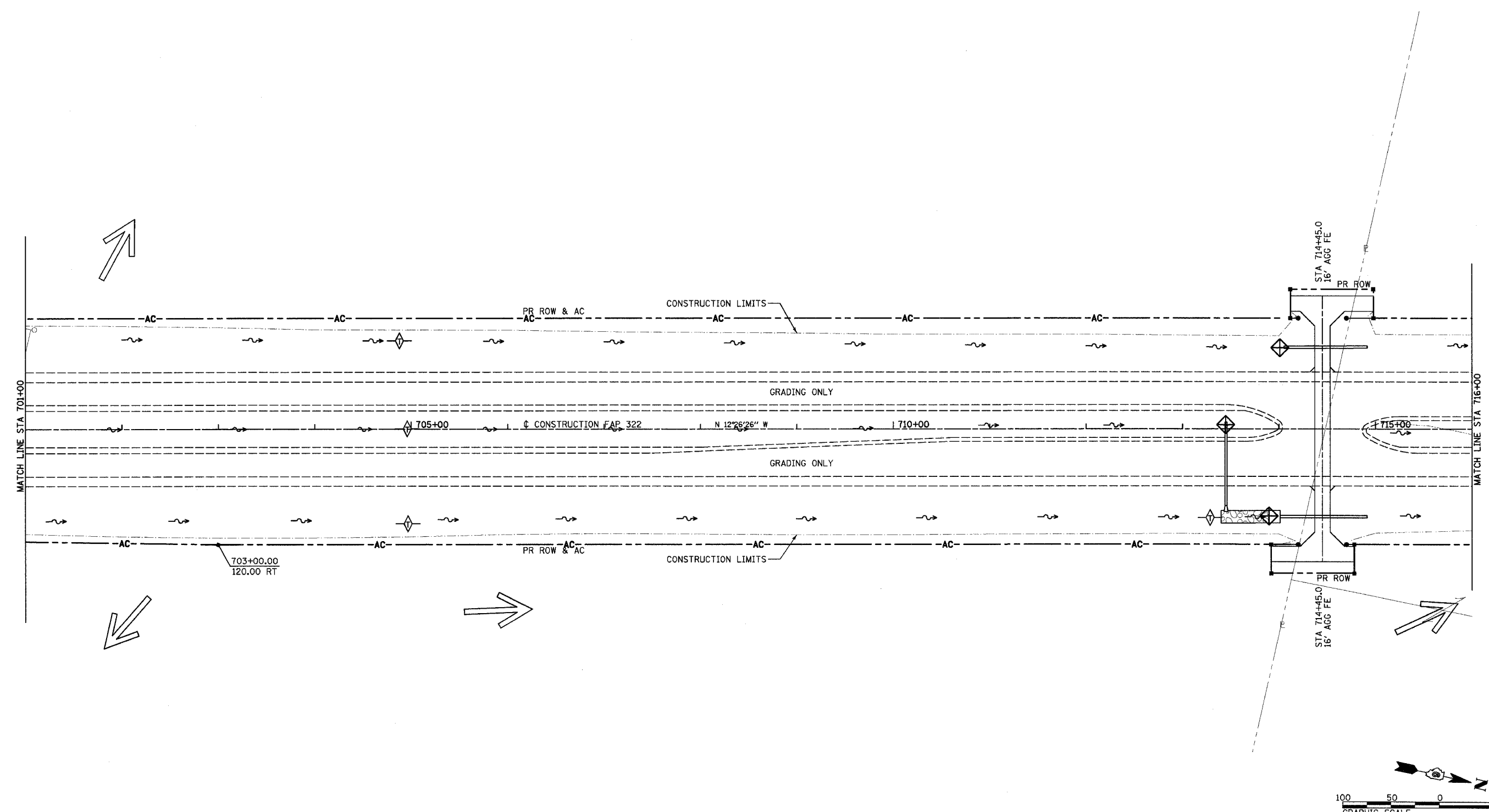

3/29/2005

F:\MTF\lan\210224\work\tbl\lan\118-01.dwg

REVISIONS	
NAME	DATE

ILLINOIS DEPARTMENT OF TRANSPORTATION
 STORM WATER POLLUTION
 PREVENTION PLAN
 FAP 322 (US 51)
 SECTION 11-1
 CHRISTIAN COUNTY

SCALE: 1"=50' DRAWN BY: BDJ
 DATE: 3/18/05 CHECKED BY: SEB

FAP 322 (US 51) STA 701+00 TO STA 716+00

F.A.P. RTE.	SECTION	COUNTY	TOTAL SHEETS	SHEET NO.
322	11-10	CHRISTIAN	310	144
STA.		TO STA.		
FED. ROAD DIST. NO.	ILLINOIS	FED. AID PROJECT		

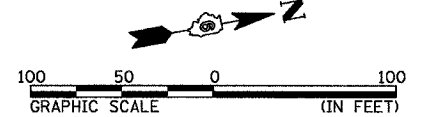
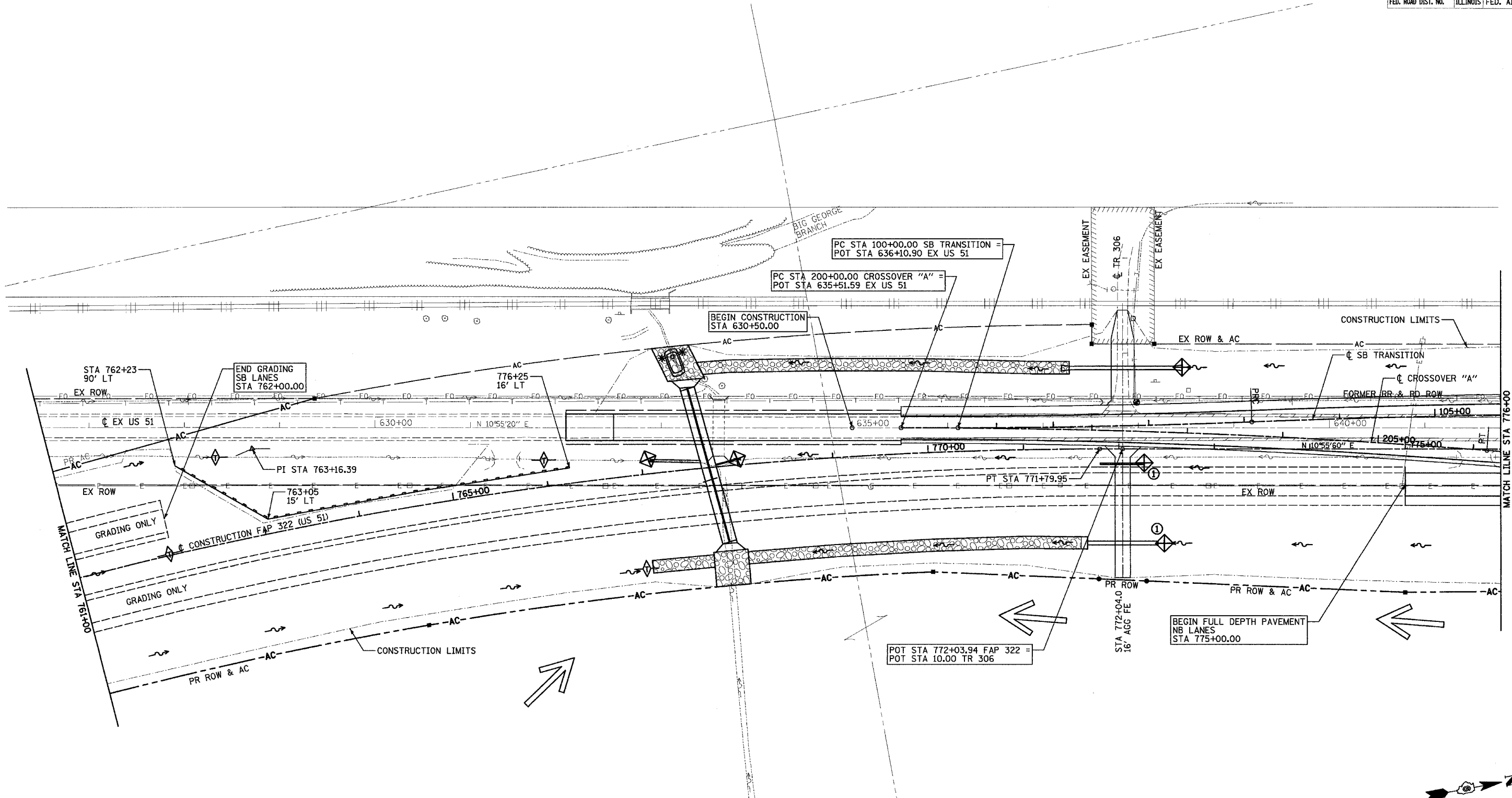

REVISIONS	
NAME	DATE

ILLINOIS DEPARTMENT OF TRANSPORTATION
STORM WATER POLLUTION PREVENTION PLAN
 FAP 322 (US 51)
 SECTION 11-1
 CHRISTIAN COUNTY

SCALE: 1"=50'
 DATE: 3/18/05

DRAWN BY: BDJ
 CHECKED BY: SEB

4/18/2005

SW 1/4 SEC 24, T13N, R1E, 3RD PM

92677

F.A.P. RTE.	SECTION	COUNTY	TOTAL SHEETS	SHEET NO.
322	11-10	CHRISTIAN	310	147
STA.		TO STA.		
FED. ROAD DIST. NO.	ILLINOIS	FED. AID PROJECT		

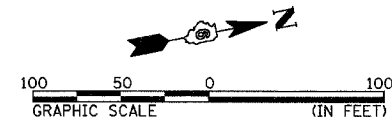
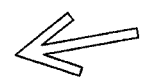
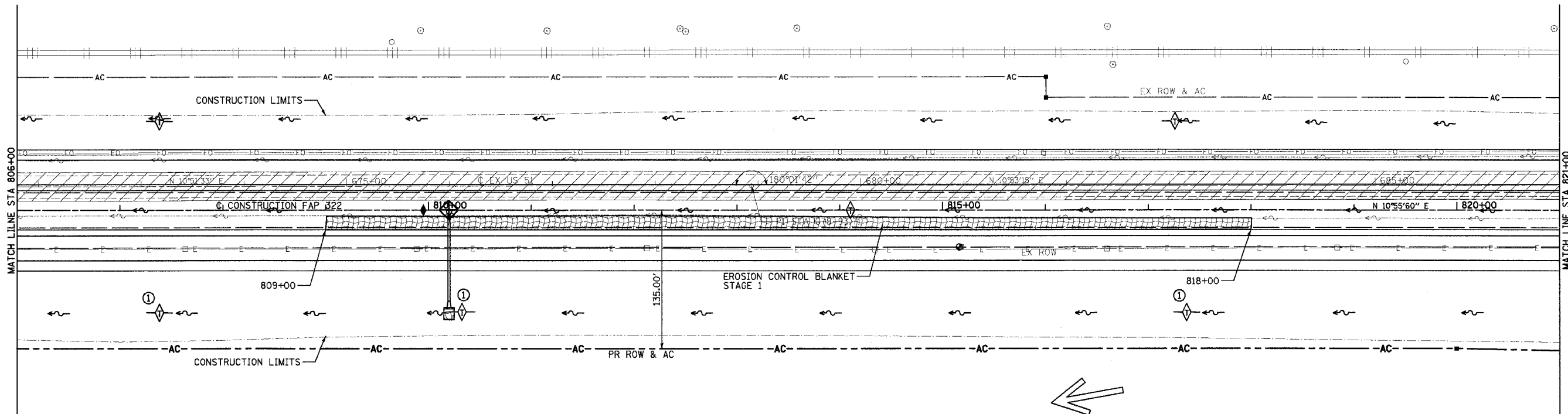

REVISIONS	
NAME	DATE

ILLINOIS DEPARTMENT OF TRANSPORTATION
 STORM WATER POLLUTION
 PREVENTION PLAN
 FAP 322 (US 51)
 SECTION 11-1
 CHRISTIAN COUNTY

SCALE: 1"=50'
 DATE: 3/18/05

DRAWN BY: BDJ
 CHECKED BY: SEB

SW 1/4 SEC 24, T13N, R1E, 3RD PM

FAP 322 (US 51) STA 806+00 TO STA 821+00

3/29/2005

\\s:\f\lan\2005\24\storm\plan\11-1.dwg

SW 1/4 SEC 13, T13N, R1E, 3RD PM

F.A.P. RTE.	SECTION	COUNTY	TOTAL SHEETS	SHEET NO.
322	11-10	CHRISTIAN	310	150
STA.		TO STA.		
FED. ROAD DIST. NO.	ILLINOIS	FED. AID PROJECT		

7

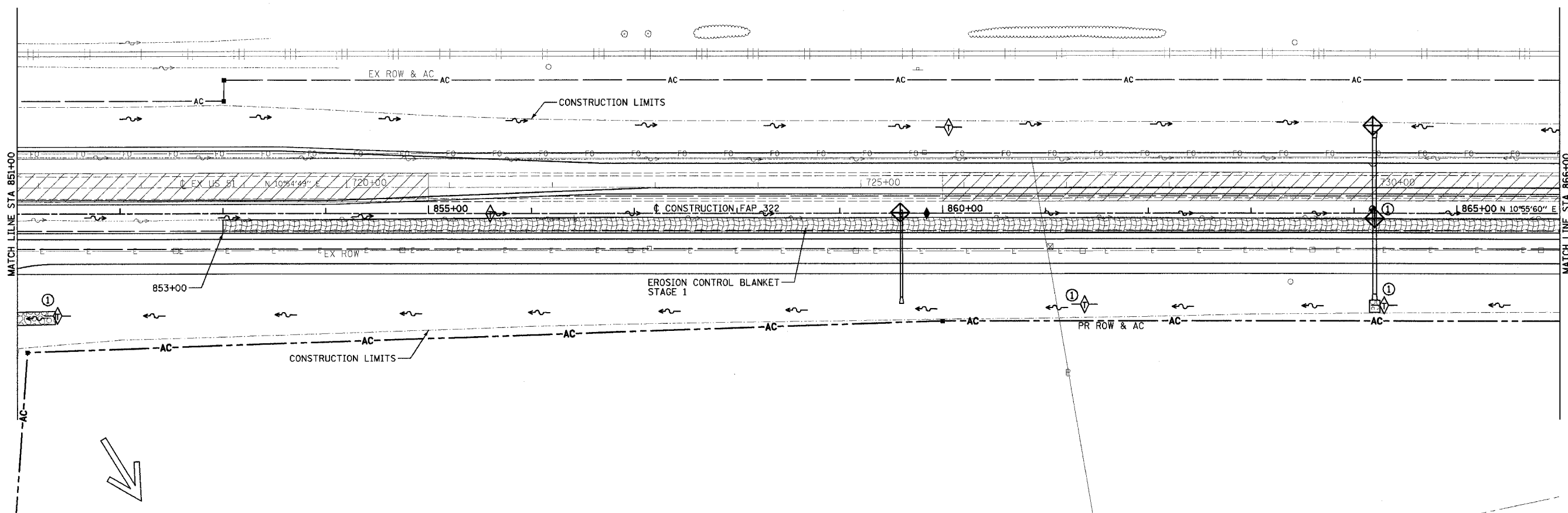

3/21/2005

\\s111\lea\102225\new\plans\159\mch.dwg

SW 1/4 SEC 13, T13N, R1E, 3RD PM

REVISIONS	
NAME	DATE

ILLINOIS DEPARTMENT OF TRANSPORTATION
 STORM WATER POLLUTION PREVENTION PLAN
 FAP 322 (US 51)
 SECTION 11-1
 CHRISTIAN COUNTY

SCALE: 1"=50'
 DATE: 3/18/05
 DRAWN BY: BDJ
 CHECKED BY: SEB

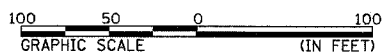

FAP 322 (US 51) STA 851+00 TO STA 866+00

SW 1/4 SEC 13, T13N, R1E, 3RD PM

NW 1/4 SEC 13, T13N, R1E, 3RD PM

F.A.P. RTE.	SECTION	COUNTY	TOTAL SHEETS	SHEET NO.
322	11-10	CHRISTIAN	310	151
STA.		TO STA.		
FED. ROAD DIST. NO.	ILLINOIS	FED. AID PROJECT		

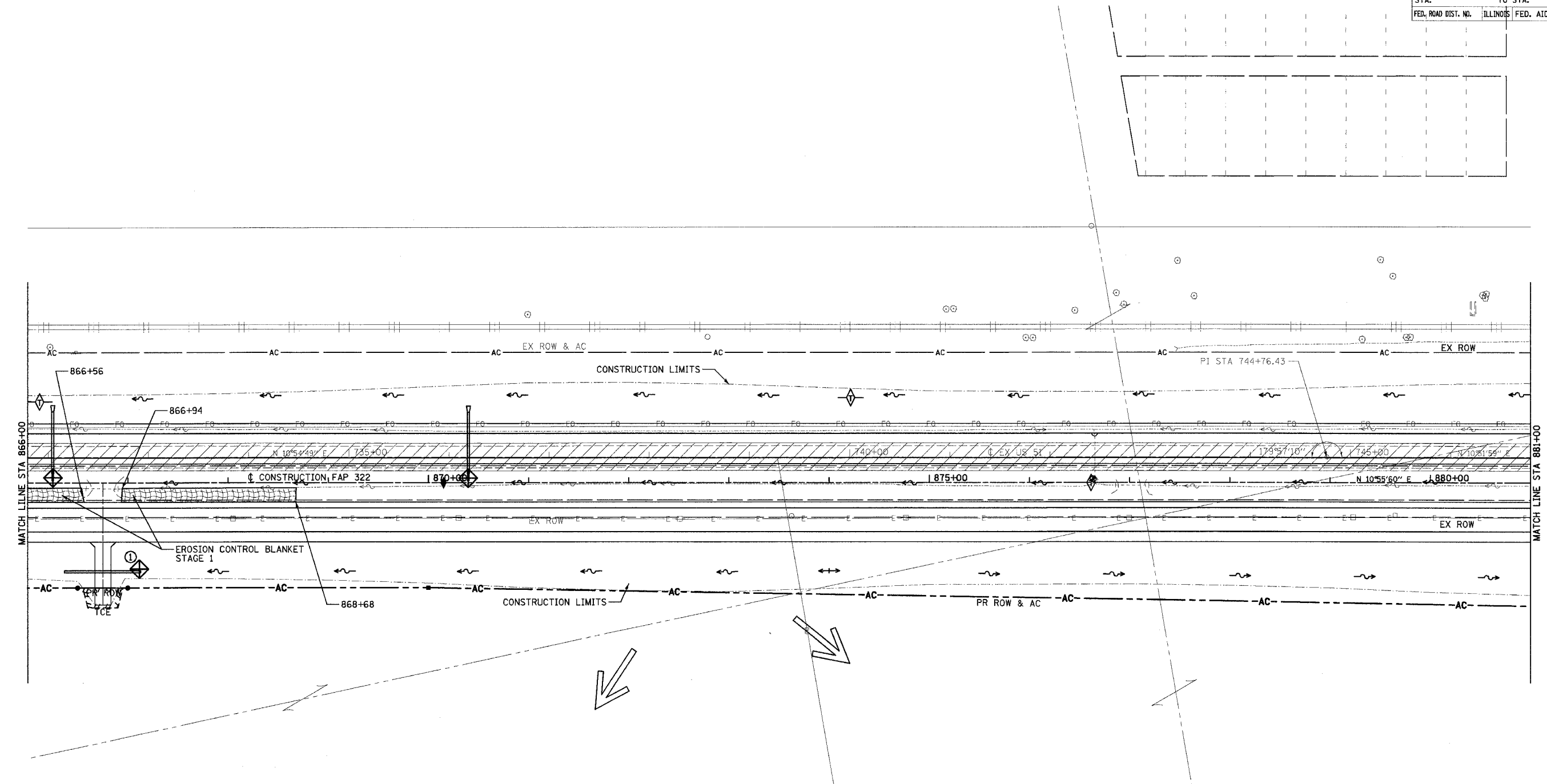

3/29/2005

P:\E:\I\era\0729\work\plan\11\11st1.dwg

SE 1/4 SEC 13, T13N, R1E, 3RD PM

NE 1/4 SEC 13, T13N, R1E, 3RD PM

REVISIONS	
NAME	DATE

ILLINOIS DEPARTMENT OF TRANSPORTATION
 STORM WATER POLLUTION
 PREVENTION PLAN
 FAP 322 (US 51)
 SECTION 11-1
 CHRISTIAN COUNTY

SCALE: 1"=50'
 DATE: 3/18/05

DRAWN BY: BDJ
 CHECKED BY: SEB

FAP 322 (US 51) STA 866+00 TO STA 881+00

NW 1/4 SEC 13, T13N, R1E, 3RD PM

F.A.P. RTE.	SECTION	COUNTY	TOTAL SHEETS	SHEET NO.
322	11-10	CHRISTIAN	310	152
STA.		TO STA.		
FED. ROAD DIST. NO.		ILLINOIS FED. AID PROJECT		

NE 1/4 SEC 13, T13N, R1E, 3RD PM

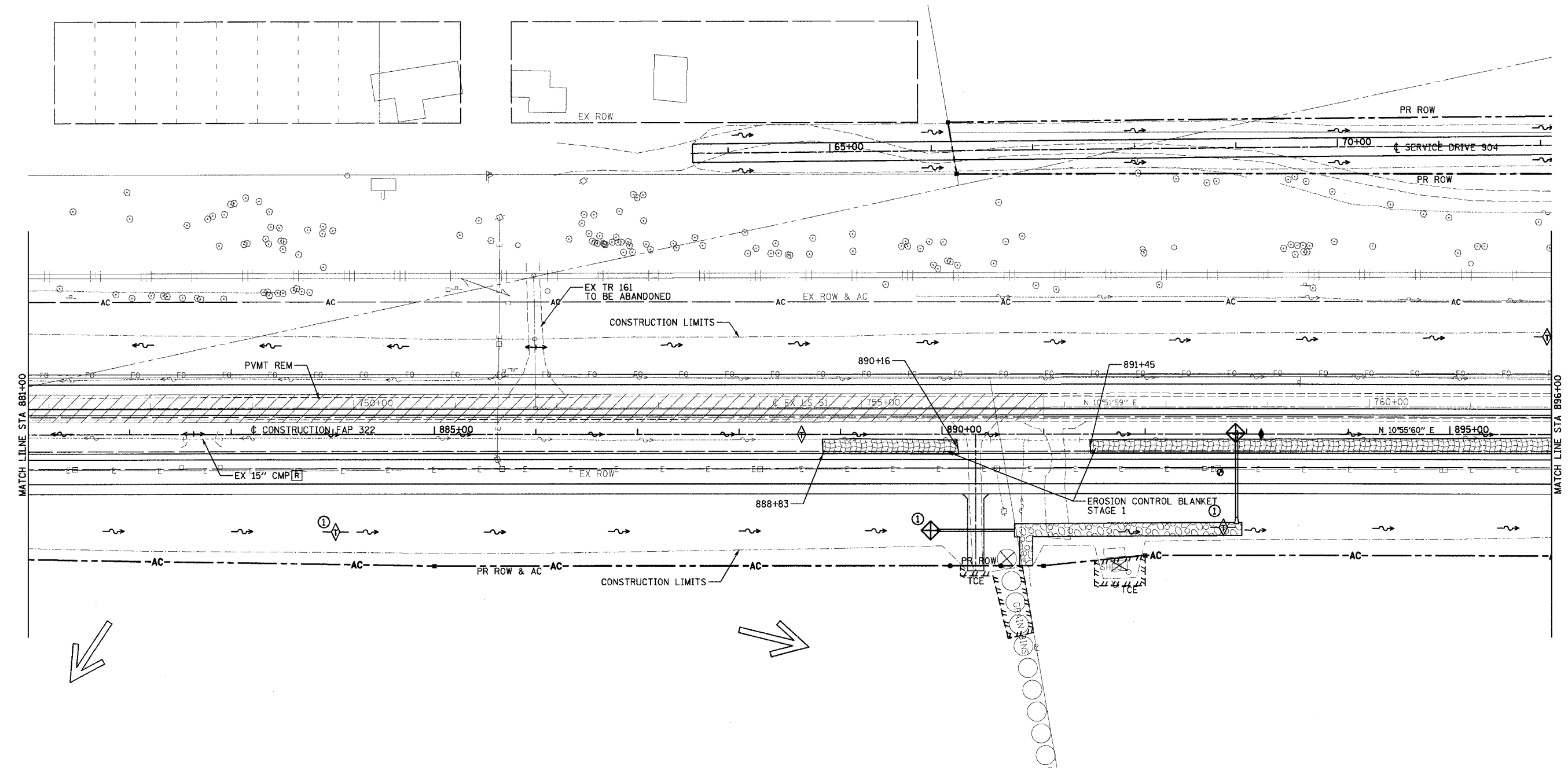

MATCH LINE STA 881+00

MATCH LINE STA 896+00

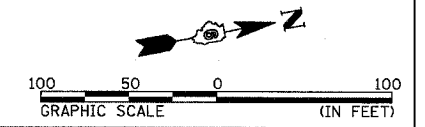
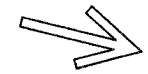
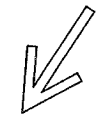

REVISIONS	
NAME	DATE

ILLINOIS DEPARTMENT OF TRANSPORTATION
 STORM WATER POLLUTION
 PREVENTION PLAN
 FAP 322 (US 51)
 SECTION 11-1
 CHRISTIAN COUNTY

SCALE: 1"=50' DRAWN BY: BDJ
 DATE: 3/18/05 CHECKED BY: SEB

NE 1/4 SEC 13, T13N, R1E, 3RD PM

FAP 322 (US 51) STA 881+00 TO STA 896+00

SE 1/4 SEC 12, T13N, R1E, 3RD PM

NE 1/4 SEC 12, T13N, R1E, 3RD PM

F.A.P. RTE.	SECTION	COUNTY	TOTAL SHEETS	SHEET NO.
322	11-10	CHRISTIAN	310	155
STA.		TO STA.		
FED. ROAD DIST. NO.	ILLINOIS FED. AID PROJECT			

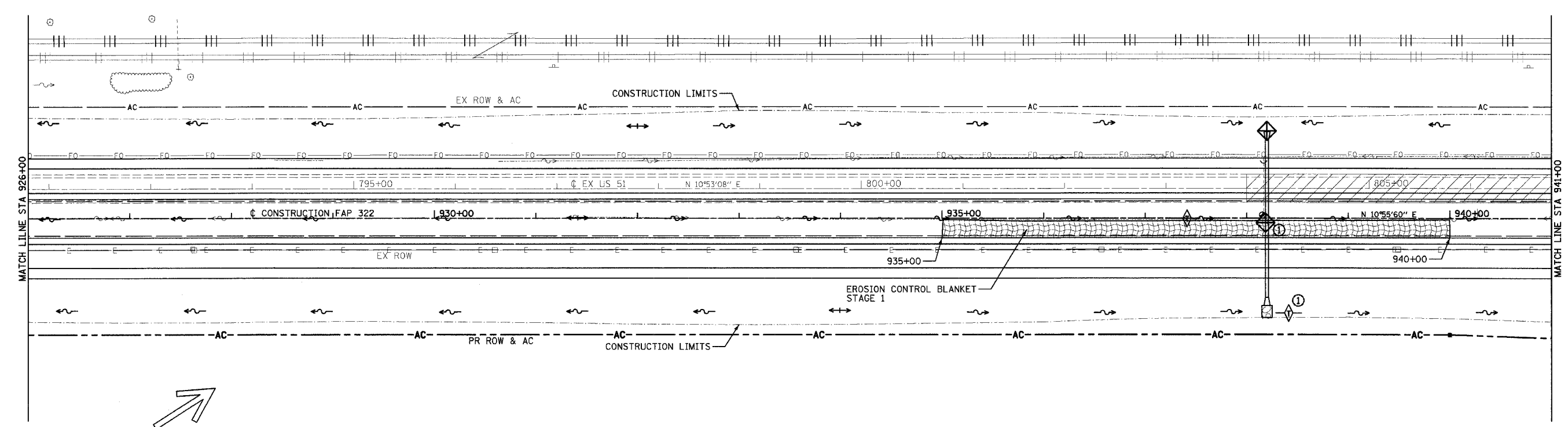

SE 1/4 SEC 12, T13N, R1E, 3RD PM

NE 1/4 SEC 12, T13N, R1E, 3RD PM

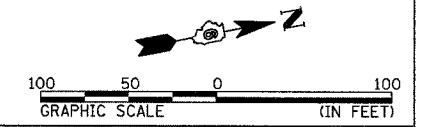

REVISIONS	
NAME	DATE

ILLINOIS DEPARTMENT OF TRANSPORTATION
 STORM WATER POLLUTION
 PREVENTION PLAN
 FAP 322 (US 51)
 SECTION 11-1
 CHRISTIAN COUNTY

SCALE: 1"=50'
 DATE: 3/18/05

DRAWN BY: BDJ
 CHECKED BY: SEB

FAP 322 (US 51) STA 926+00 TO STA 941+00

F.A.P. RTE.	SECTION	COUNTY	TOTAL SHEETS	SHEET NO.
322	11-10	CHRISTIAN	310	156
STA.		TO STA.		
FED. ROAD DIST. NO.		ILLINOIS FED. AID PROJECT		

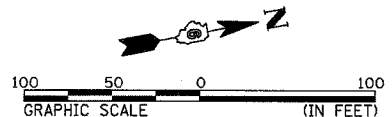
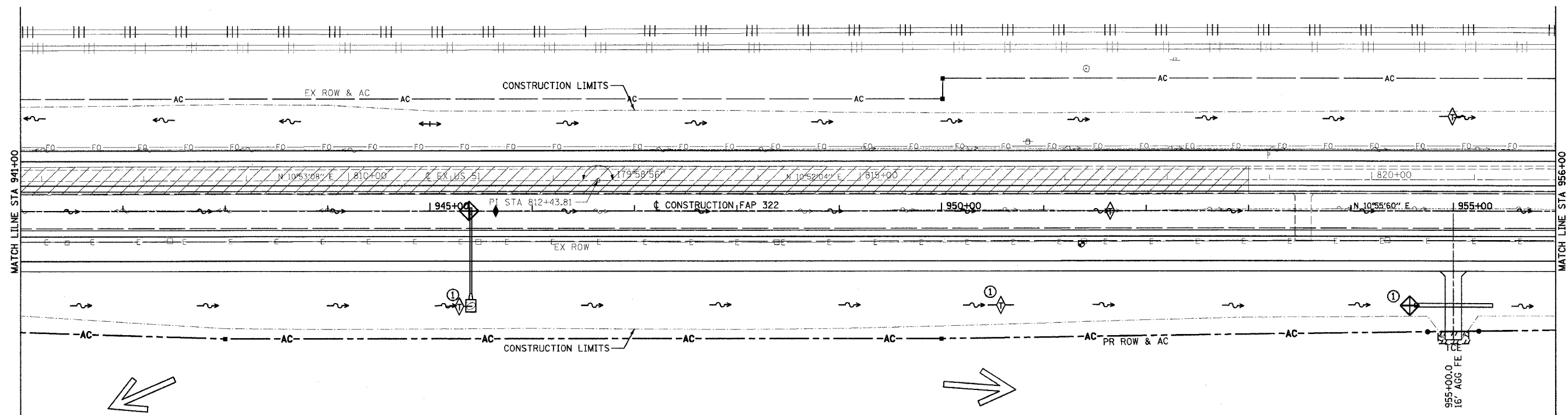

REVISIONS	
NAME	DATE

ILLINOIS DEPARTMENT OF TRANSPORTATION
 STORM WATER POLLUTION
 PREVENTION PLAN
 FAP 322 (US 51)
 SECTION 11-1
 CHRISTIAN COUNTY

SCALE: 1"=50'
 DATE: 3/18/05

DRAWN BY: BDJ
 CHECKED BY: SEB

NE 1/4 SEC 12, T13N, R1E, 3RD PM

SE 1/4 SEC 1, T13N, R1E, 3RD PM

F.A.P. RTE.	SECTION	COUNTY	TOTAL SHEETS	SHEET NO.
322	11-10	CHRISTIAN	310	157
STA.		TO STA.		
FED. ROAD DIST. NO.		ILLINOIS FED. AID PROJECT		

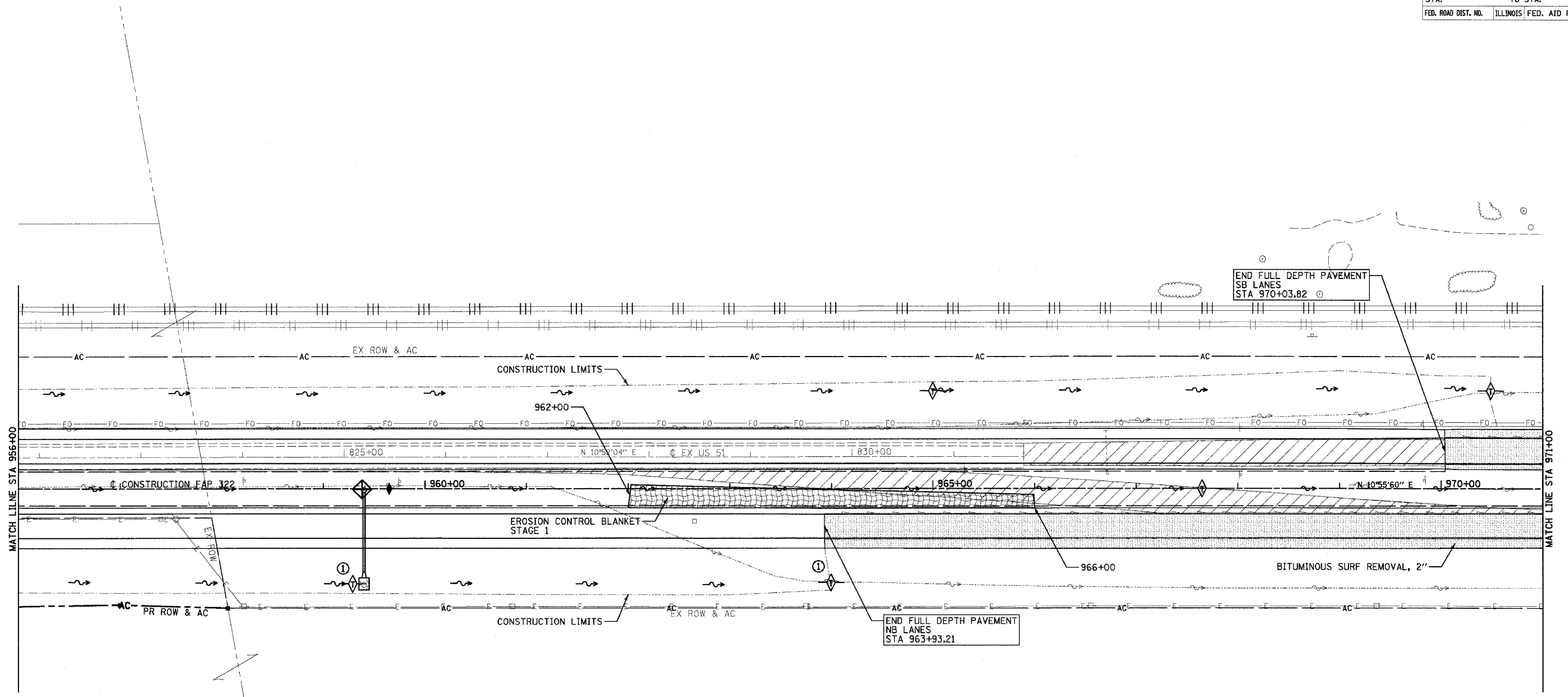

END FULL DEPTH PAVEMENT
SB LANES
STA 970+03.82

END FULL DEPTH PAVEMENT
NB LANES
STA 963+93.21

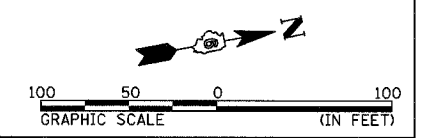

REVISIONS	
NAME	DATE

ILLINOIS DEPARTMENT OF TRANSPORTATION
STORM WATER POLLUTION
PREVENTION PLAN
FAP 322 (US 51)
SECTION 11-1
CHRISTIAN COUNTY

SCALE: 1"=50' DRAWN BY: BDJ
DATE: 3/18/05 CHECKED BY: SEB

FAP 322 (US 51) STA 956+00 TO STA 971+00

NE 1/4 SEC 12, T13N, R1E, 3RD PM

SE 1/4 SEC 1, T13N, R1E, 3RD PM

3/29/2005

\\nbf\eg\GIS\Projects\FAP322\157.ec28.dgn

F.A.P. RTE.	SECTION	COUNTY	TOTAL SHEETS	SHEET NO.
322	11-10	CHRISTIAN	310	160
STA.		TO STA.		
FED. ROAD DIST. NO.		ILLINOIS FED. AID PROJECT		

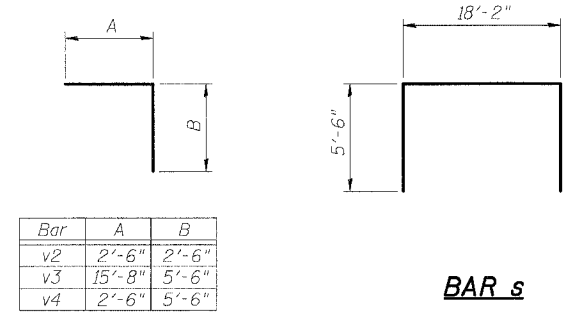

Bar	A	B
v2	2'-6"	2'-6"
v3	15'-8"	5'-6"
v4	2'-6"	5'-6"

BAR s

BAR s1

BILL OF MATERIAL

Bar	No.	Size	Length	Shape
a	1	#4	1'-5"	—
a1	1	#4	1'-8"	—
a2	1	#4	2'-0"	—
a3	1	#4	2'-3"	—
a4	1	#4	2'-6"	—
a5	1	#4	2'-9"	—
a6	1	#4	3'-0"	—
a7	1	#4	3'-4"	—
a8	1	#4	3'-7"	—
a9	1	#4	3'-10"	—
a10	2	#8	18'-2"	—
b	2	#5	18'-0"	—
b1	2	#5	20'-6"	—
b2	1	#4	22'-9"	—
b3	1	#4	25'-10"	—
b4	1	#4	28'-10"	—
b5	1	#4	31'-11"	—
b6	2	#4	35'-0"	—
h	1	#5	13'-9"	—
h1	1	#5	18'-10"	—
h2	1	#5	15'-6"	—
h3	5	#4	10'-11"	—
h4	5	#4	13'-5"	—
s	4	#6	29'-2"	—
s1	19	#4	4'-3"	—
v	7	#5	16'-0"	—
v1	6	#5	16'-0"	—
v2	23	#4	5'-0"	—
v3	4	#5	21'-2"	—
v4	4	#5	8'-0"	—
CONCRETE HEADWALLS			CU YD	15.3
REINFORCEMENT BARS			POUND	1090

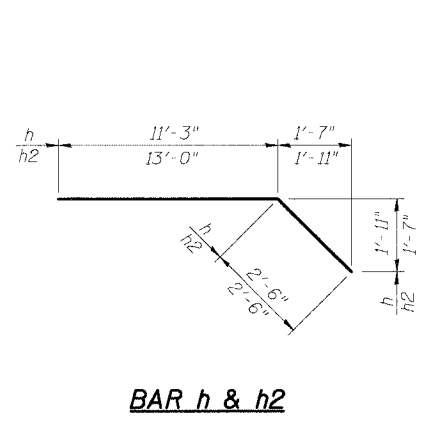

BAR h & h2

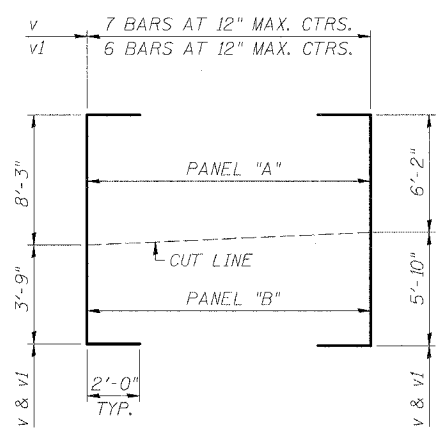

**FIELD CUTTING DIAGRAM
BARS v & v1**

NOTES:
 TABLE FOR (1) HEADWALL ONLY. TWO (2) HEADWALLS REQUIRED. BAR DIMENSIONS ARE OUT TO OUT.
 CONCRETE HEADWALLS SHALL BE USED THROUGHOUT.
 EXPOSED EDGES SHALL BE BEVELED 3/4".
 REINFORCEMENT BARS SHALL CONFORM TO THE REQUIREMENTS OF ASSHTO M-31, M-42, M-53, GRADE 60
 NOT TO SCALE OR PROPER ORIENTATION.

(DRAWING NOT TO SCALE)
 SHEET #2 OF 2

REVISIONS	
NAME	DATE

ILLINOIS DEPARTMENT OF TRANSPORTATION
 CAST-IN-PLACE END SECTIONS
 STA 767+70.0 LT. & RT.
 FAP 322 (US 51)
 SECTION 11-1
 CHRISTIAN COUNTY
 SCALE: NOT TO SCALE
 DATE: 02/09/05
 DRAWN BY: EAW
 CHECKED BY: ADL

3/29/2005 p:\bl\lisa\01\222\un\cpl\area\16\h\truss2.dgn

F.A.P. RTE.	SECTION	COUNTY	TOTAL SHEETS	SHEET NO.
322	11-10	CHRISTIAN	310	161
STA.		TO STA.		
FED. ROAD DIST. NO.		ILLINOIS FED. AID PROJECT		

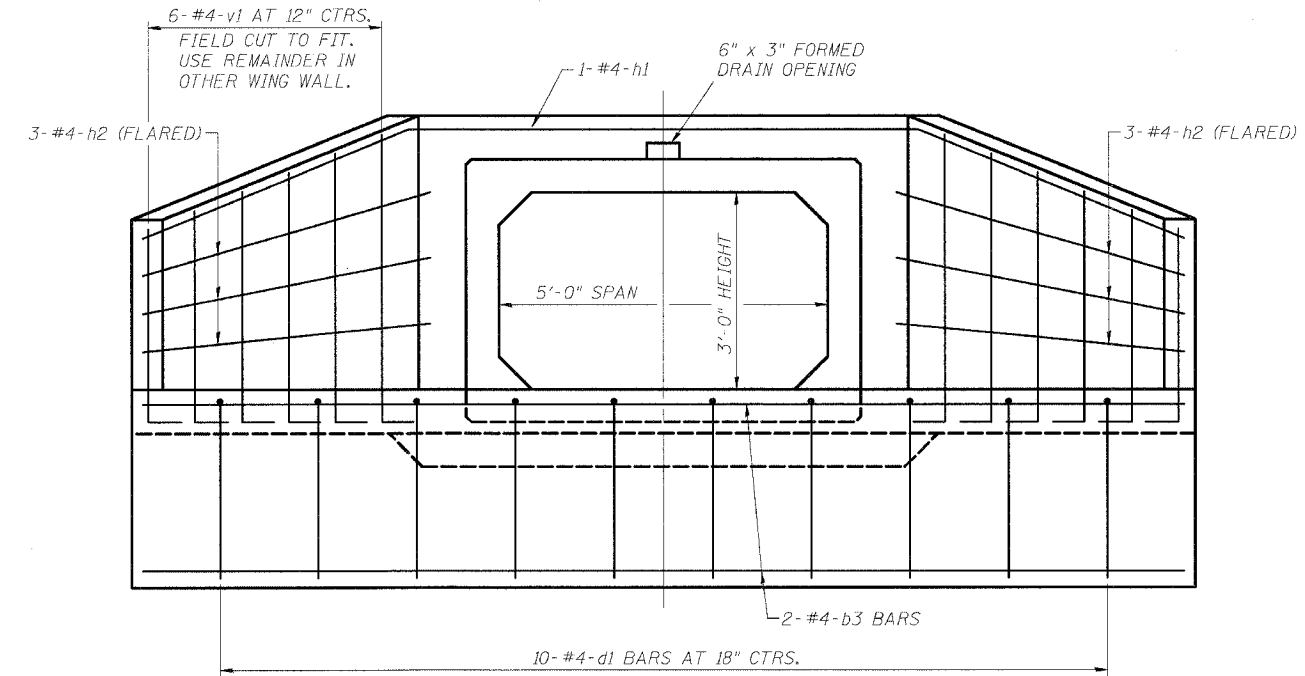

END ELEVATION

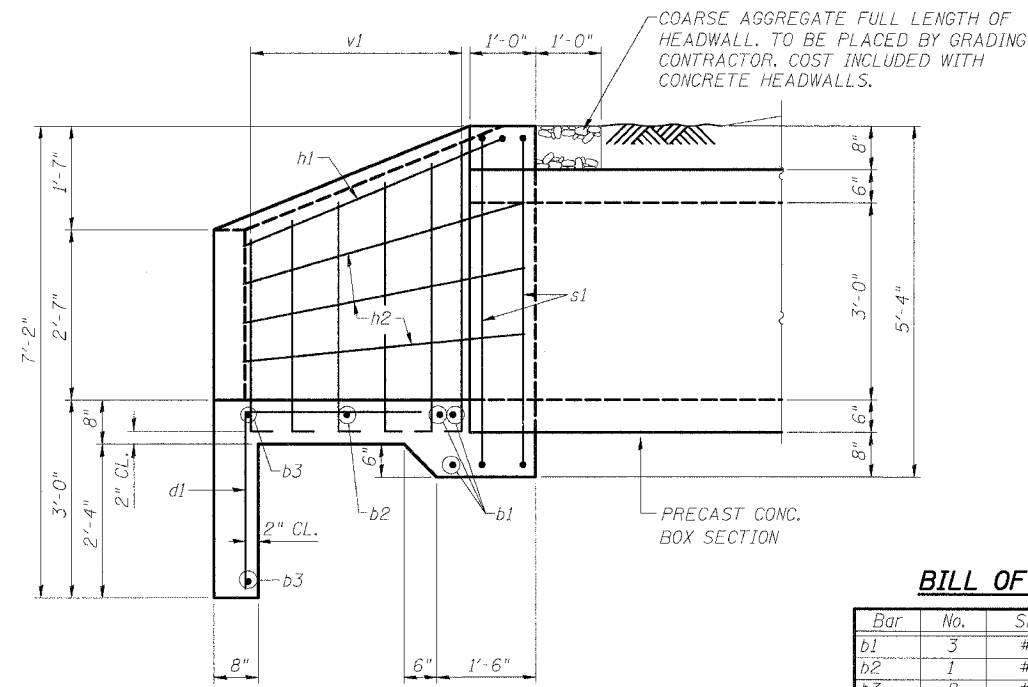

SECTION A-A

BILL OF MATERIAL

Bar	No.	Size	Length	Shape
b1	3	#4	9'-2"	—
b2	1	#4	12'-7"	—
b3	2	#4	15'-10"	—
d1	10	#4	5'-4"	└
h1	1	#4	19'-7"	∩
h2	6	#4	5'-11"	—
s1	2	#4	24'-11"	□
v1	6	#4	11'-3"	└
CONCRETE HEADWALLS			CU YD	3.9
REINFORCEMENT BARS			POUND	200

NOTES:

TABLE FOR (1) HEADWALL ONLY. TWO (2) HEADWALLS REQUIRED. BAR DIMENSIONS ARE OUT TO OUT.

CONCRETE HEADWALLS SHALL BE USED THROUGHOUT.

EXPOSED EDGES SHALL BE BEVELED 3/4".

REINFORCEMENT BARS SHALL CONFORM TO THE REQUIREMENTS OF ASSHTO M-31, M-42, M-53, GRADE 60

NOT TO SCALE OR PROPER ORIENTATION.

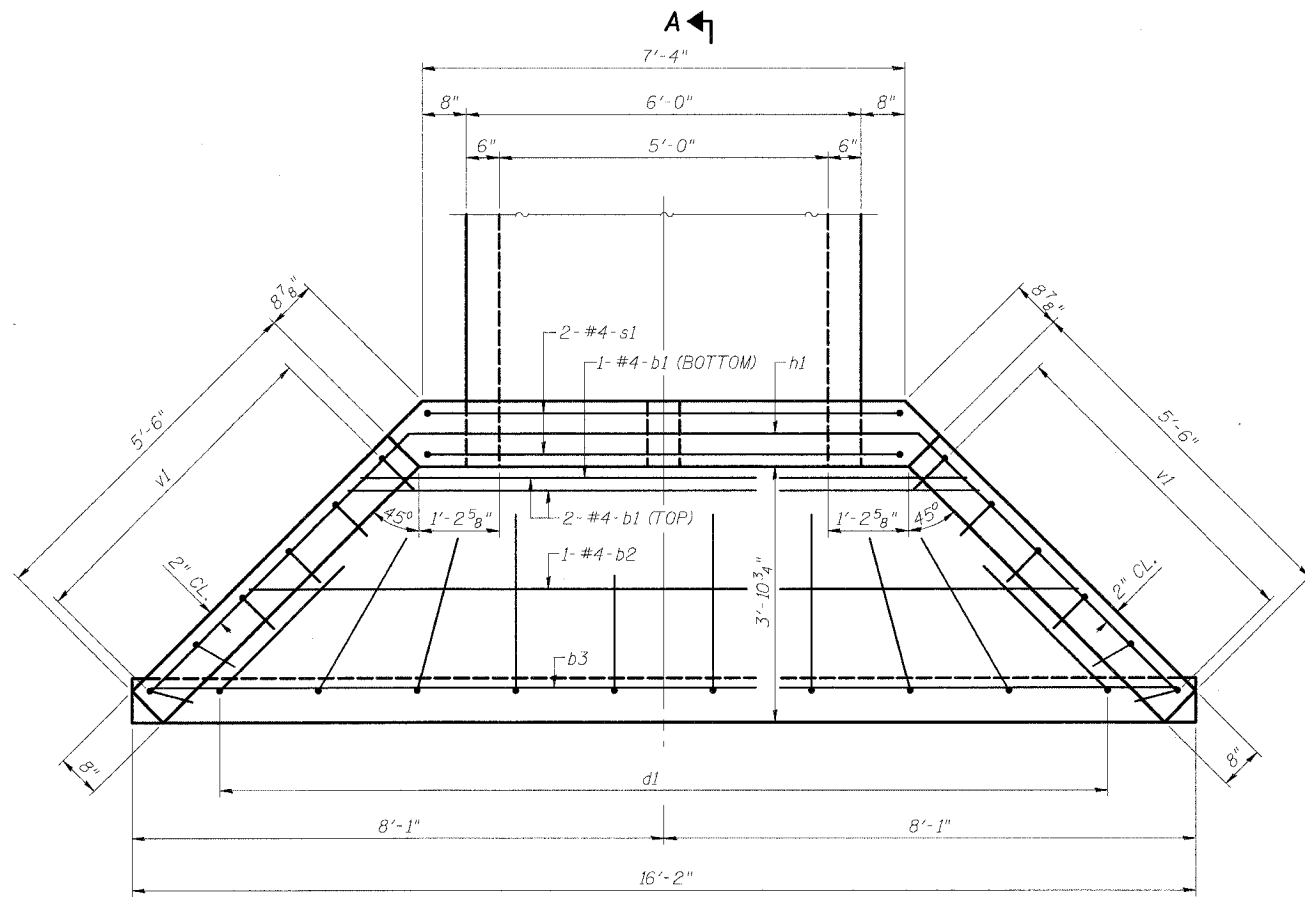

PLAN

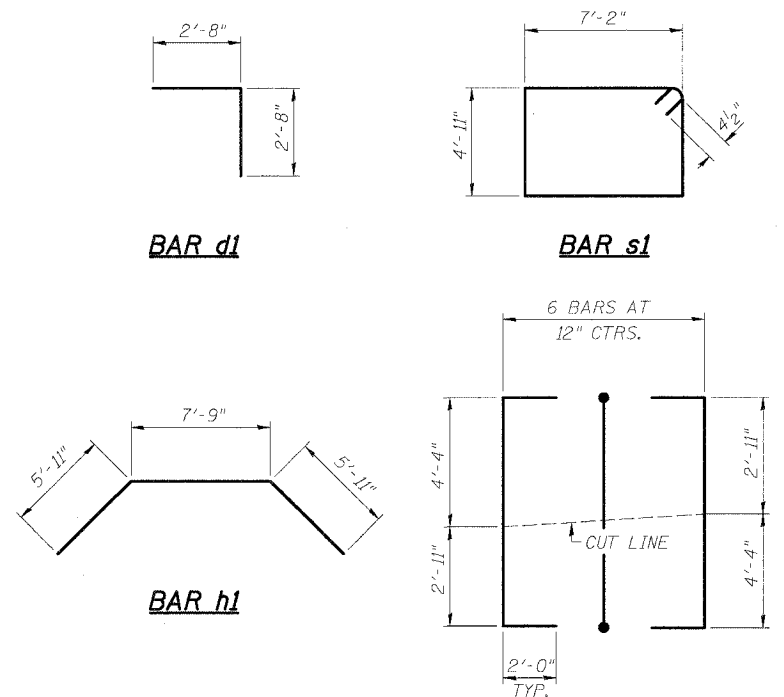

FIELD CUTTING DIAGRAM BARS v1

REVISIONS	
NAME	DATE

ILLINOIS DEPARTMENT OF TRANSPORTATION
 CAST-IN-PLACE END SECTIONS
 - STA 924+75 LT. & RT.
 FAP 322 (US 51)
 SECTION 11-1
 CHRISTIAN COUNTY

SCALE: NOT TO SCALE
 DATE: 02/09/05

DRAWN BY: EAW
 CHECKED BY: ADL

3/27/2005

F.A.P. RTE.	SECTION	COUNTY	TOTAL SHEETS	SHEET NO.
322	11-10	CHRISTIAN	310	162
STA.		TO STA.		
FED. ROAD DIST. NO.	ILLINOIS	FED. AID PROJECT		

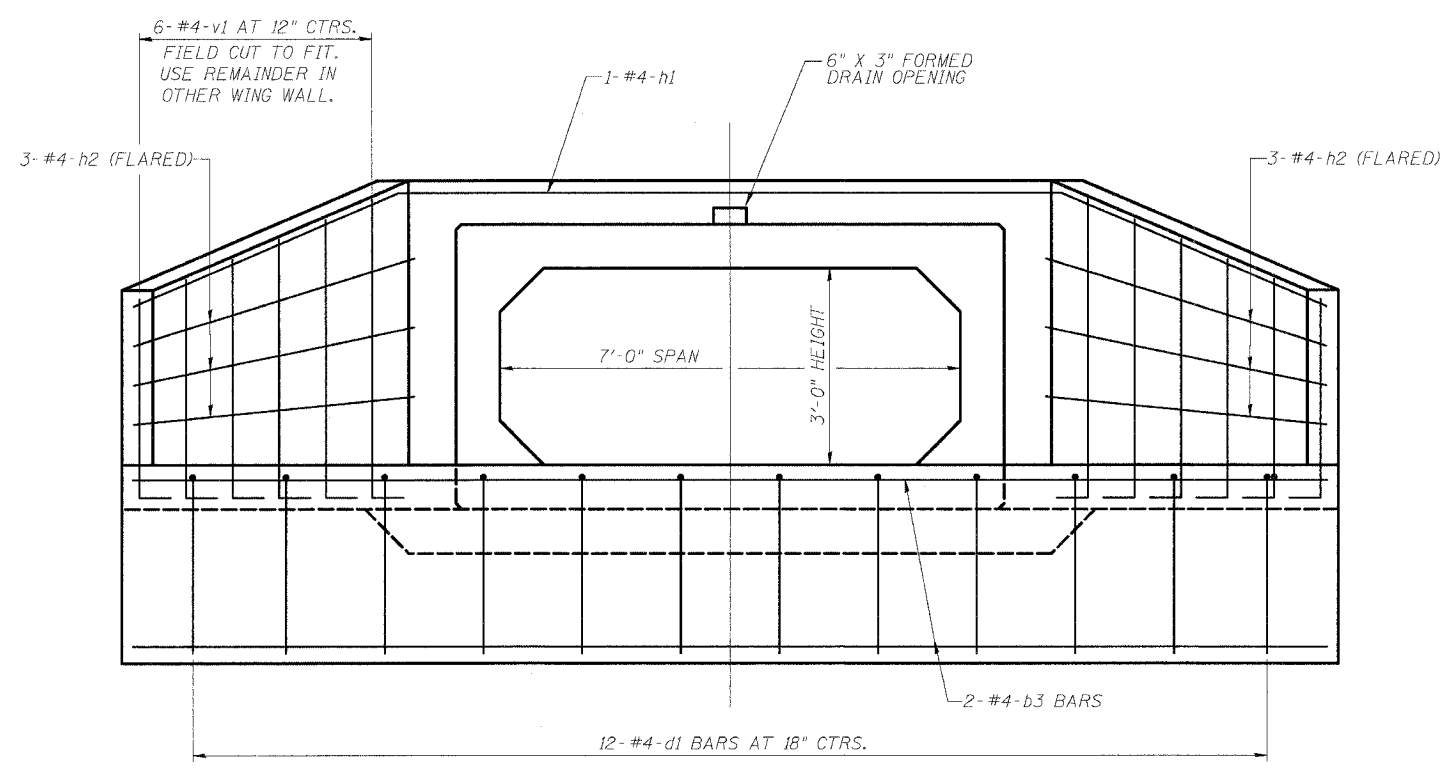

END ELEVATION

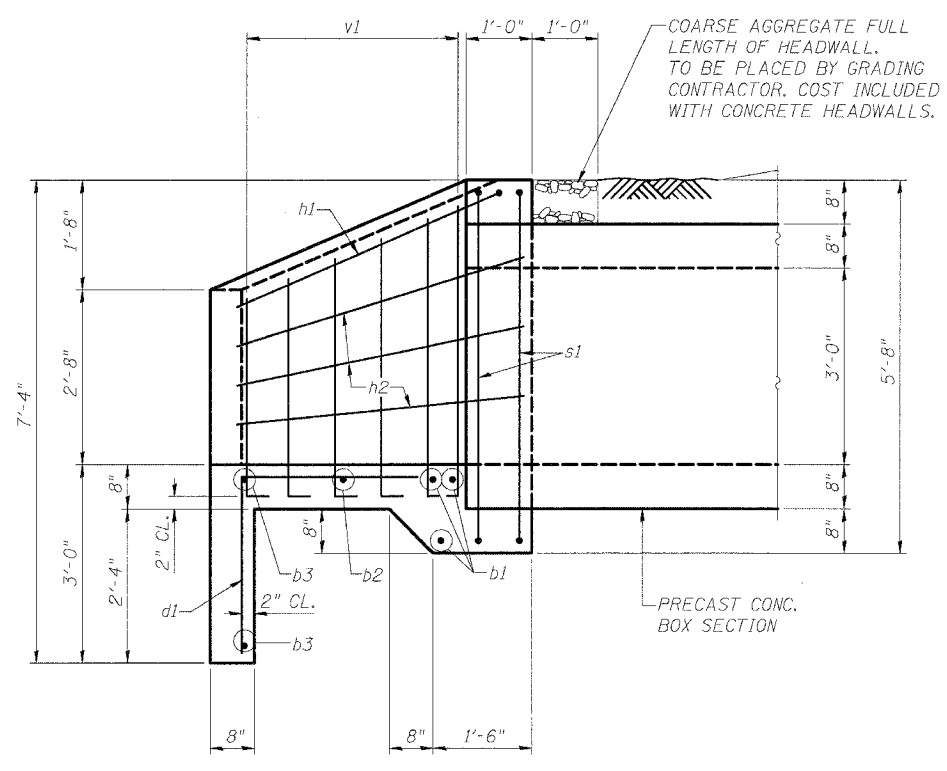

SECTION A-A

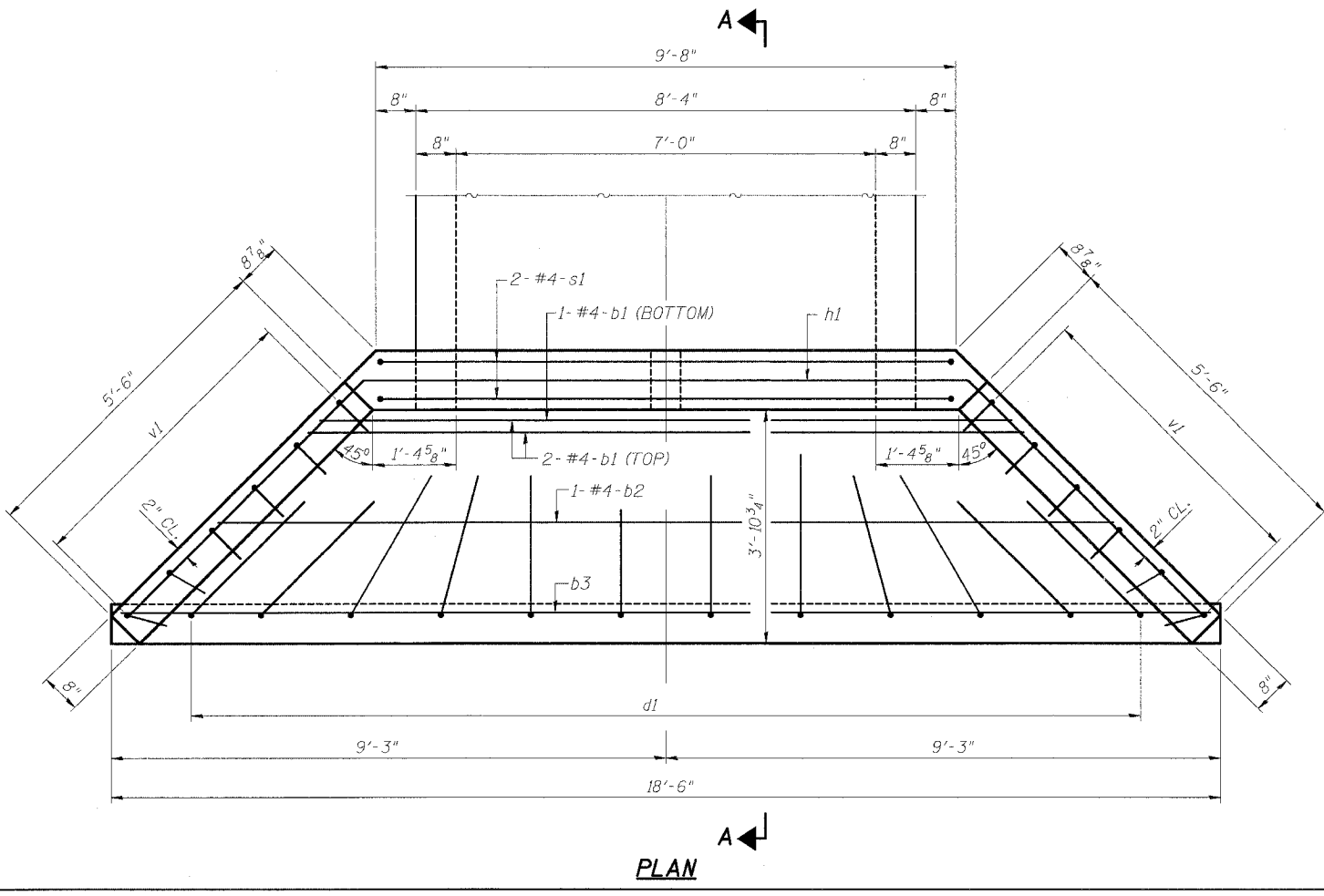

PLAN

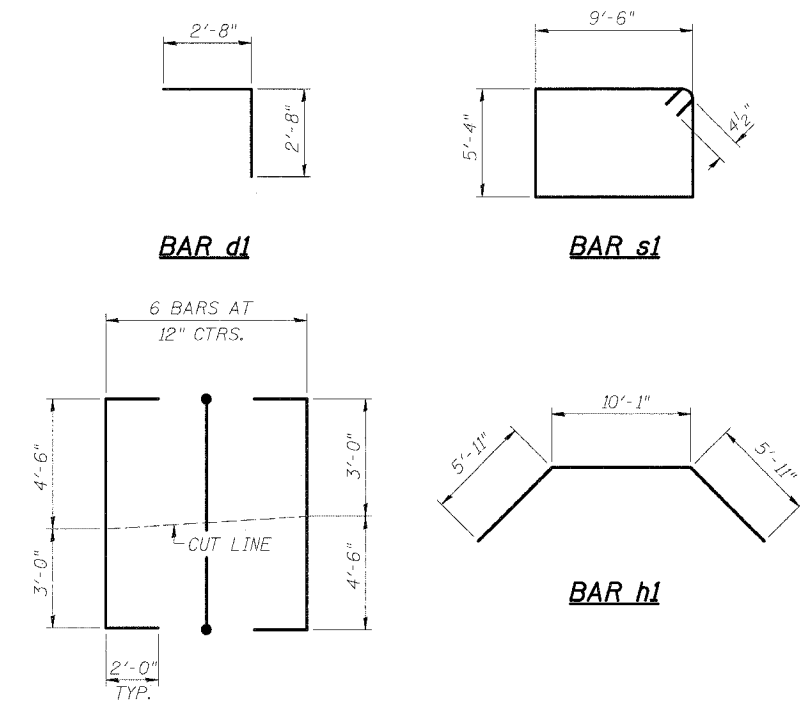

FIELD CUTTING DIAGRAM BARS v1

BILL OF MATERIAL

Bar	No.	Size	Length	Shape
b1	3	#4	11'-6"	—
b2	1	#4	14'-11"	—
b3	2	#4	18'-2"	—
d1	12	#4	5'-4"	└
h1	1	#4	21'-11"	┌
h2	6	#4	6'-2"	—
s1	2	#4	30'-5"	□
v1	6	#4	11'-6"	└
CONCRETE HEADWALLS			CU YD	4.6
REINFORCEMENT BARS			POUND	230

NOTES:
 TABLE FOR (1) HEADWALL ONLY. TWO (2) HEADWALLS REQUIRED. BAR DIMENSIONS ARE OUT TO OUT.
 CONCRETE HEADWALLS SHALL BE USED THROUGHOUT.
 EXPOSED EDGES SHALL BE BEVELED 3/4".
 REINFORCEMENT BARS SHALL CONFORM TO THE REQUIREMENTS OF ASSHTO M-31, M-42, M-53, GRADE 60
 NOT TO SCALE OR PROPER ORIENTATION.

SHEET #1 OF 1

REVISIONS	
NAME	DATE

ILLINOIS DEPARTMENT OF TRANSPORTATION
 CAST-IN-PLACE END SECTIONS
 -STA 11+40 TR 151A LT. & RT.
 FAP 322 (US 51)
 SECTION 11-1
 CHRISTIAN COUNTY
 SCALE: NOT TO SCALE
 DATE: 02/09/05
 DRAWN BY: EAW
 CHECKED BY: ADL

3/29/2005

F.A.P. RTE.	SECTION	COUNTY	TOTAL SHEETS	SHEET NO.
322	11-10	CHRISTIAN	310	163
STA.		TO STA.		
FED. ROAD DIST. NO.	ILLINOIS	FED. AID PROJECT		

FAP 322 CURVE (PI STA 763+16.39)											
SECTION	STATION	OUTSIDE EDGE	SLOPE %	CL	SLOPE %	MEDIAN EDGE	MEDIAN EDGE	SLOPE %	CL	SLOPE %	OUTSIDE EDGE
A	752+61.00	624.22	-1.50	624.40	-1.50	624.22	624.22	-1.50	624.40	-1.50	624.22
	752+75.00	624.24	-0.99	624.36	-1.50	624.18	624.18	-0.99	624.29	-1.50	624.11
	753+00.00	624.27	-0.07	624.28	-1.50	624.10	624.10	-0.07	624.11	-1.50	623.93
B	753+02.00	624.27	0.00	624.27	-1.50	624.09	624.09	0.00	624.09	-1.50	623.91
	753+25.00	624.27	0.51	624.21	-1.50	624.03	624.03	0.51	623.96	-1.50	623.78
	753+50.00	624.26	1.07	624.13	-1.50	623.95	623.95	1.07	623.82	-1.50	623.64
C	753+69.50	624.25	1.50	624.07	-1.50	623.89	623.89	1.50	623.71	-1.50	623.53
	753+75.00	624.26	1.62	624.07	-1.62	623.88	623.88	1.62	623.68	-1.50	623.50
	754+00.00	624.32	2.18	624.06	-2.18	623.80	623.80	2.18	623.54	-2.18	623.28
	754+25.00	624.38	2.73	624.05	-2.73	623.73	623.73	2.73	623.40	-2.73	623.07
D	754+28.00	624.39	2.80	624.05	-2.80	623.72	623.72	2.80	623.38	-2.80	623.04
	754+50.00	624.44	3.29	624.04	-3.29	623.65	623.65	3.29	623.26	-3.29	622.86
	754+75.00	624.50	3.84	624.04	-3.84	623.58	623.58	3.84	623.11	-3.84	622.65
E	754+91.00	624.54	4.20	624.03	-4.20	623.53	623.53	4.20	623.02	-4.20	622.52
MAXIMUM SUPERELEVATION											
E	771+17.00	620.32	4.20	620.82	-4.20	620.32	620.32	4.20	619.81	-4.20	619.31
	771+25.00	620.33	4.02	620.81	-4.02	620.33	620.33	4.02	619.84	-4.02	619.36
	771+50.00	620.36	3.47	620.77	-3.47	620.36	620.36	3.47	619.94	-3.47	619.52
D	771+75.00	620.39	2.91	620.74	-2.91	620.39	620.39	2.91	620.04	-2.91	619.69
	771+80.00	620.40	2.80	620.73	-2.80	620.40	620.40	2.80	620.06	-2.80	619.72
	772+00.00	620.43	2.36	620.71	-2.36	620.43	620.43	2.36	620.14	-2.36	619.86
C	772+25.00	620.46	1.80	620.68	-1.80	620.46	620.46	1.80	620.25	-1.80	620.03
	772+38.50	620.49	1.50	620.67	-1.50	620.49	620.49	1.50	620.31	-1.50	620.13
	772+50.00	620.51	1.24	620.69	-1.50	620.51	620.51	1.24	620.36	-1.50	620.18
B	772+75.00	620.55	0.69	620.73	-1.50	620.55	620.55	0.69	620.47	-1.50	620.29
	773+00.00	620.60	0.13	620.78	-1.50	620.60	620.60	0.13	620.58	-1.50	620.40
	773+06.00	620.61	0.00	620.79	-1.50	620.61	620.61	0.00	620.61	-1.50	620.43
A	773+25.00	620.65	-0.70	620.83	-1.50	620.65	620.65	-0.70	620.73	-1.50	620.55
	773+47.00	620.69	-1.50	620.87	-1.50	620.69	620.69	-1.50	620.87	-1.50	620.69

NOTE:
ELEVATIONS GIVEN ARE FOR FINAL PAVING

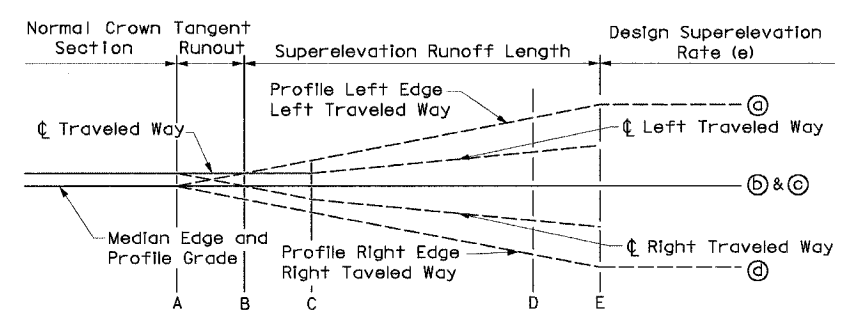

AXIS OF ROTATION ABOUT MEDIAN EDGES OF TRAVELED WAY

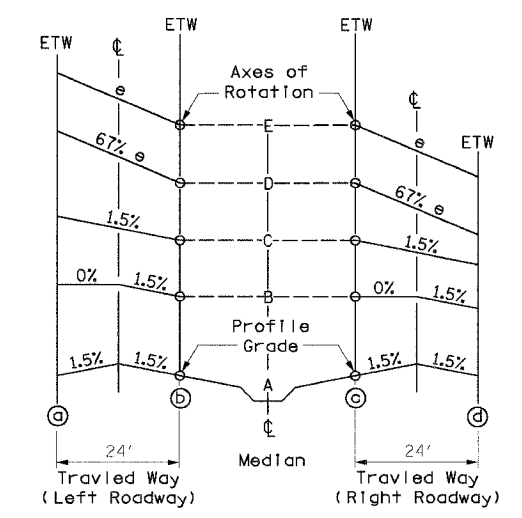

REVISIONS	
NAME	DATE

ILLINOIS DEPARTMENT OF TRANSPORTATION
SUPERELEVATION RUNOFF TABLES
 4 LANE EXPRESSWAY
 FAP 322 (US 51)
 SECTION 11-1
 CHRISTIAN COUNTY

SCALE: NONE
 DATE: 3/21/05

DRAWN BY: SEB
 CHECKED BY: EBB

3/21/2005

F.A.P. RTE.	SECTION	COUNTY	TOTAL SHEETS	SHEET NO.
322	11-10	CHRISTIAN	310	165
STA.		TO STA.		
FED. ROAD DIST. NO.		ILLINOIS FED. AID PROJECT		

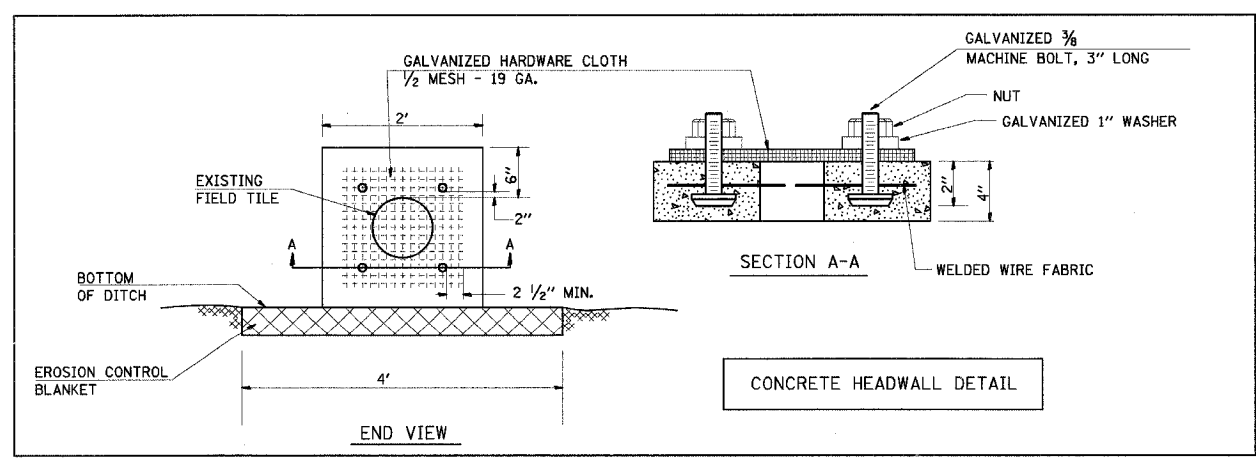
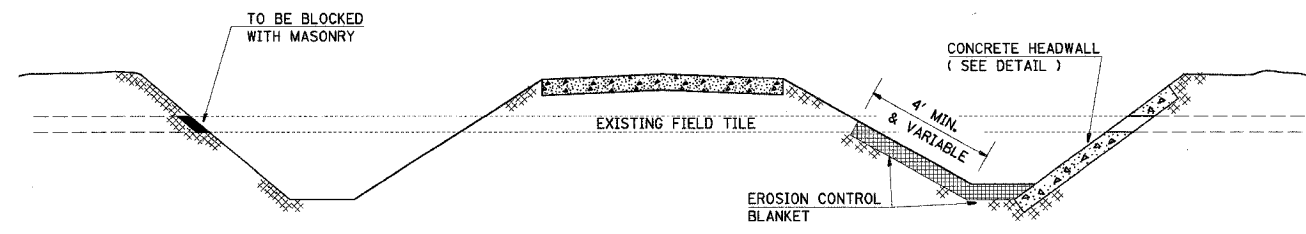
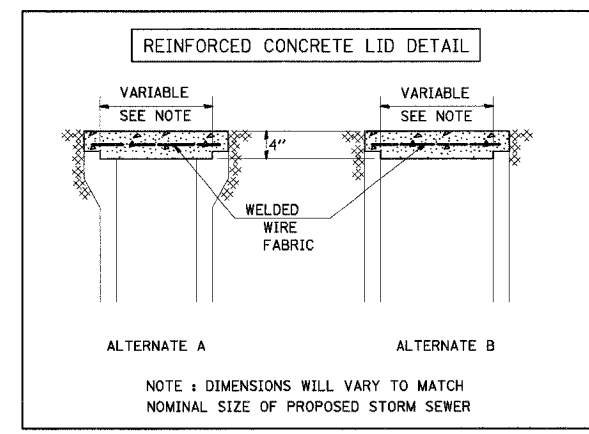
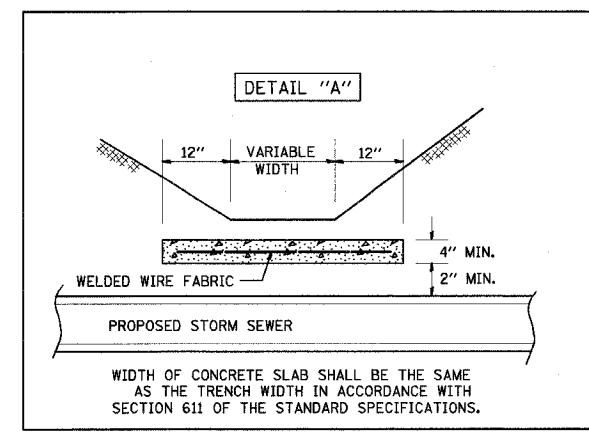
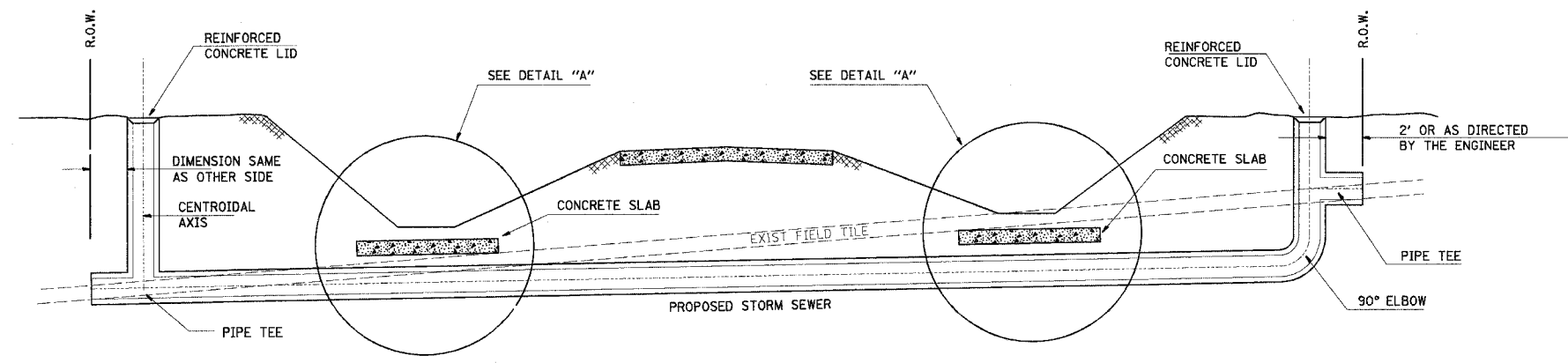

GENERAL NOTES

1. FIELD TILE SHALL BE REPLACED IN ACCORDANCE WITH SECTION 611 OF THE STANDARD SPECIFICATIONS. THE COST PER CONTRACT UNIT PRICE OF ITEMS INCLUDED IN THIS CONTRACT SHALL BE PAID FOR AS STATED IN SECTION 611 OF THE STANDARD SPECIFICATIONS. IF THE CONTRACT UNIT PRICE IS NOT INCLUDED IN THIS CONTRACT, PAYMENT FOR THIS WORK WILL BE IN ACCORDANCE WITH ARTICLE 109.04 OF THE STANDARD SPECIFICATIONS.
2. THE DIAMETER OF THE PROPOSED STORM SEWER SHALL BE EQUAL TO OR GREATER THAN THE EXISTING FIELD TILE.
3. ALL EXISTING FIELD TILE SHALL BE REPLACED WITH STORM SEWER OF THE TYPE REQUIRED FOR BY THE DEPTH OF COVER. THE LINEAL FEET MEASUREMENT WILL BE ALONG THE CENTROIDAL AXIS AND INCLUDE ALL BENDS, ELBOWS, OR PIPE TEE'S WHICH ARE REQUIRED.
4. THE REINFORCED CONCRETE LID SHALL BE CLASS SI CONCRETE (MISCELLANEOUS) OR PRECAST REINFORCED CONCRETE.

ALL DIMENSIONS ARE IN INCHES UNLESS OTHERWISE SHOWN.

REVISIONS	
NAME	DATE

ILLINOIS DEPARTMENT OF TRANSPORTATION
 MISCELLANEOUS DETAILS -
 FIELD TILE REPLACEMENT
 FAP 322 (US 51)
 SECTION 11-1
 CHRISTIAN COUNTY

SCALE: None DRAWN BY DIST. 6
 DATE CHECKED BY

3/27/2005

F.A.P. RTE.	SECTION	COUNTY	TOTAL SHEETS	SHEET NO.
322	11-10	CHRISTIAN	310	166
STA.		TO STA.		
FED. ROAD DIST. NO.		ILLINOIS FED. AID PROJECT		

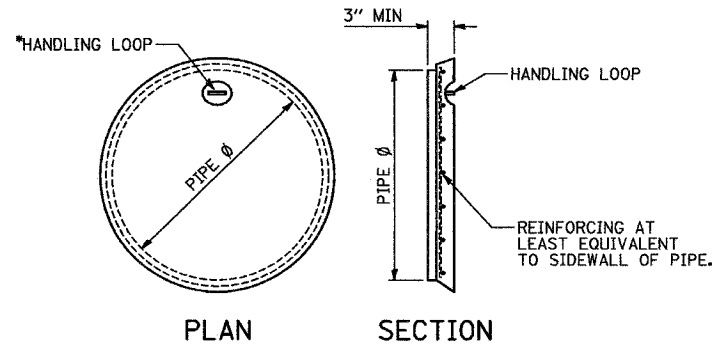

•THE HANDLING LOOP MAY BE OMITTED WHEN THE CAP IS PLACED IN A BURIED INSTALLATION.

COST OF FURNISHING AND INSTALLING CONCRETE PIPE TEE PLUG TO BE INCLUDED IN THE PAY ITEM "PIPE TEE" OF THE SIZE SPECIFIED.

DETAILS OF CONCRETE PIPE TEE PLUG

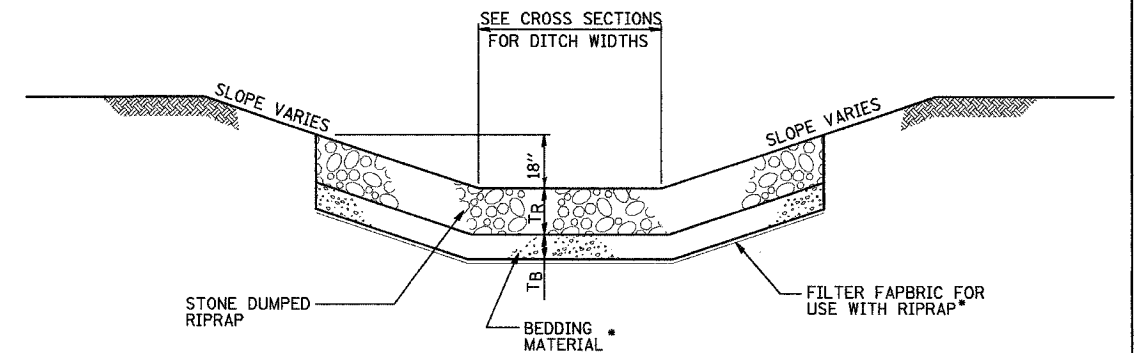

RIPRAP CLASS	RIPRAP THICKNESS (TR)	BEDDING THICKNESS (TB)
B3	8"	•
A4	16"	6"
A5	22"	8"

•STONE DUMP RIPRAP CLASS B-3 HAS NO BEDDING MATERIAL OR FILTER FABRIC UNLESS IN SANDY SOILS.

TYPICAL STONE RIPRAP DITCH LINING
SEE SCHEDULE FOR INSTALLATION LOCATIONS

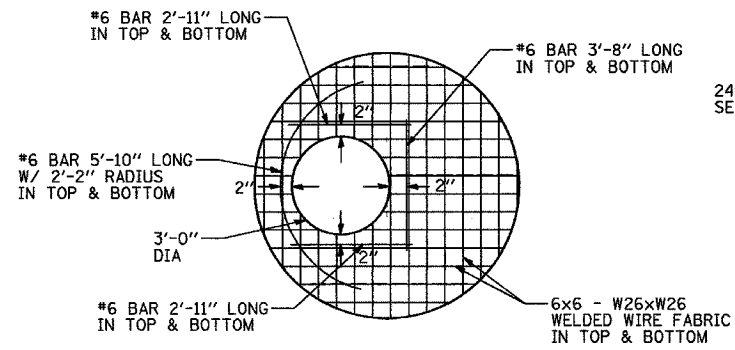

5' FLAT SLAB TOP DETAIL WITH 36" OPENING

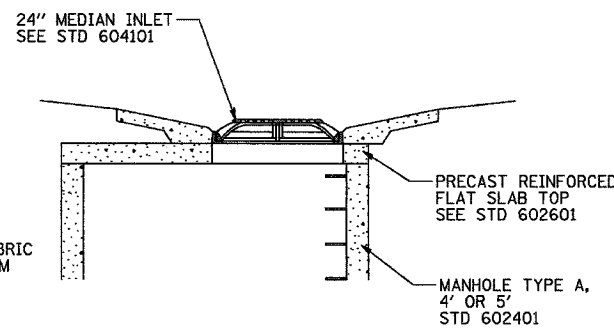

DETAIL OF STANDARD 24" MEDIAN INLET OF FLAT SLAB TOP

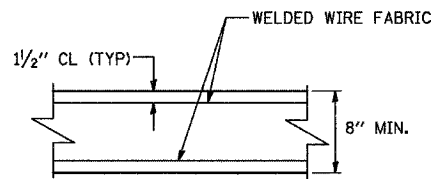

TYPICAL SLAB TOP SECTION FOR 5' OR 6' MANHOLES

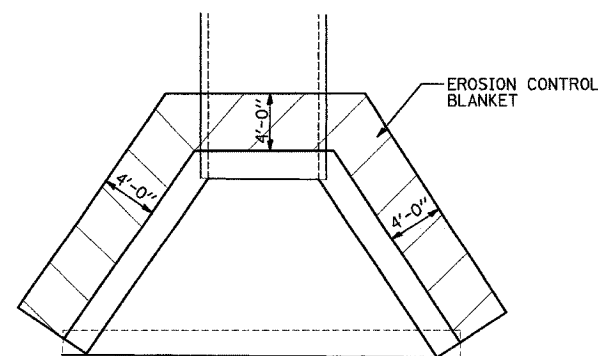

EROSION CONTROL BLANKET AROUND HEADWALLS & CULVERT WINGWALLS

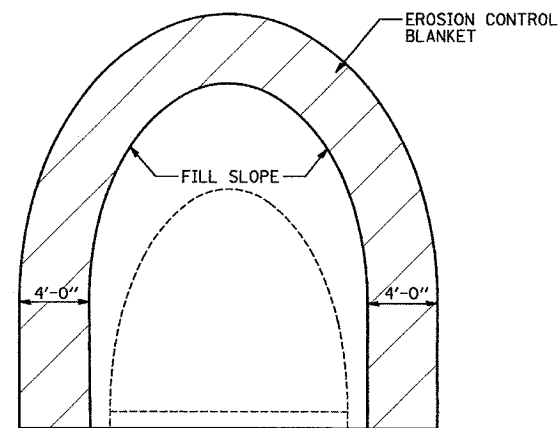

EROSION CONTROL BLANKET AROUND FLARED END SECTION STD. 542301

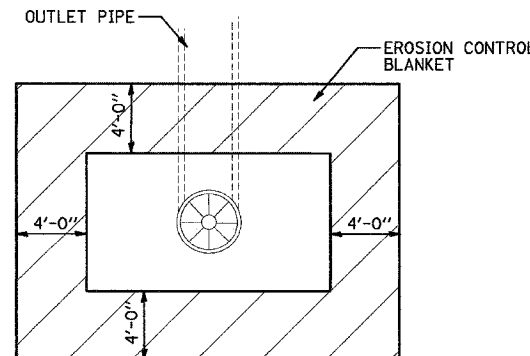

EROSION CONTROL BLANKET AROUND MEDIAN INLETS STD. 604101 & STD. 604106

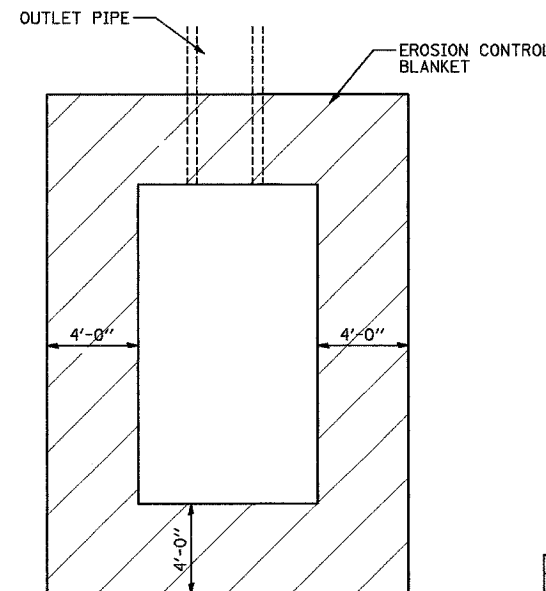

EROSION CONTROL BLANKET AROUND HEADWALL FOR PIPE UNDERDRAIN STD. 601101

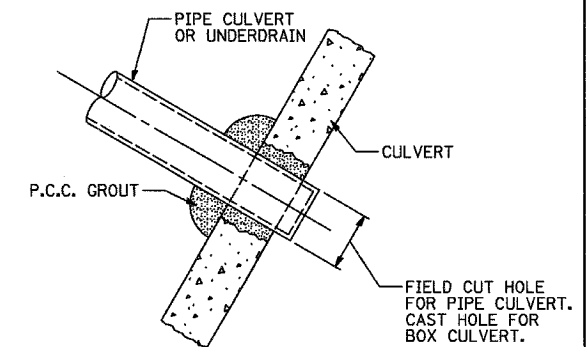

DETAIL OF PLACING PIPE IN CULVERT

NOTE: COST OF PLACING PIPE IN THE CULVERT SHALL BE INCLUDED IN THE PAY ITEM FOR THE CULVERT OR UNDERDRAIN.

REVISIONS	
NAME	DATE
PIPE NOTE - SEB	4/4/05

ILLINOIS DEPARTMENT OF TRANSPORTATION
MISCELLANEOUS DETAILS
FAP 322 (US 51)
SECTION 11-1
CHRISTIAN COUNTY
SCALE: None
DATE: 3/21/05
DRAWN BY: SEB
CHECKED BY: EBB

F.A.P. RTE.	SECTION	COUNTY	TOTAL SHEETS	SHEET NO.
322	11-10	CHRISTIAN	310	167
STA.		TO STA.		
FED. ROAD DIST. NO.	ILLINOIS FED. AID PROJECT			

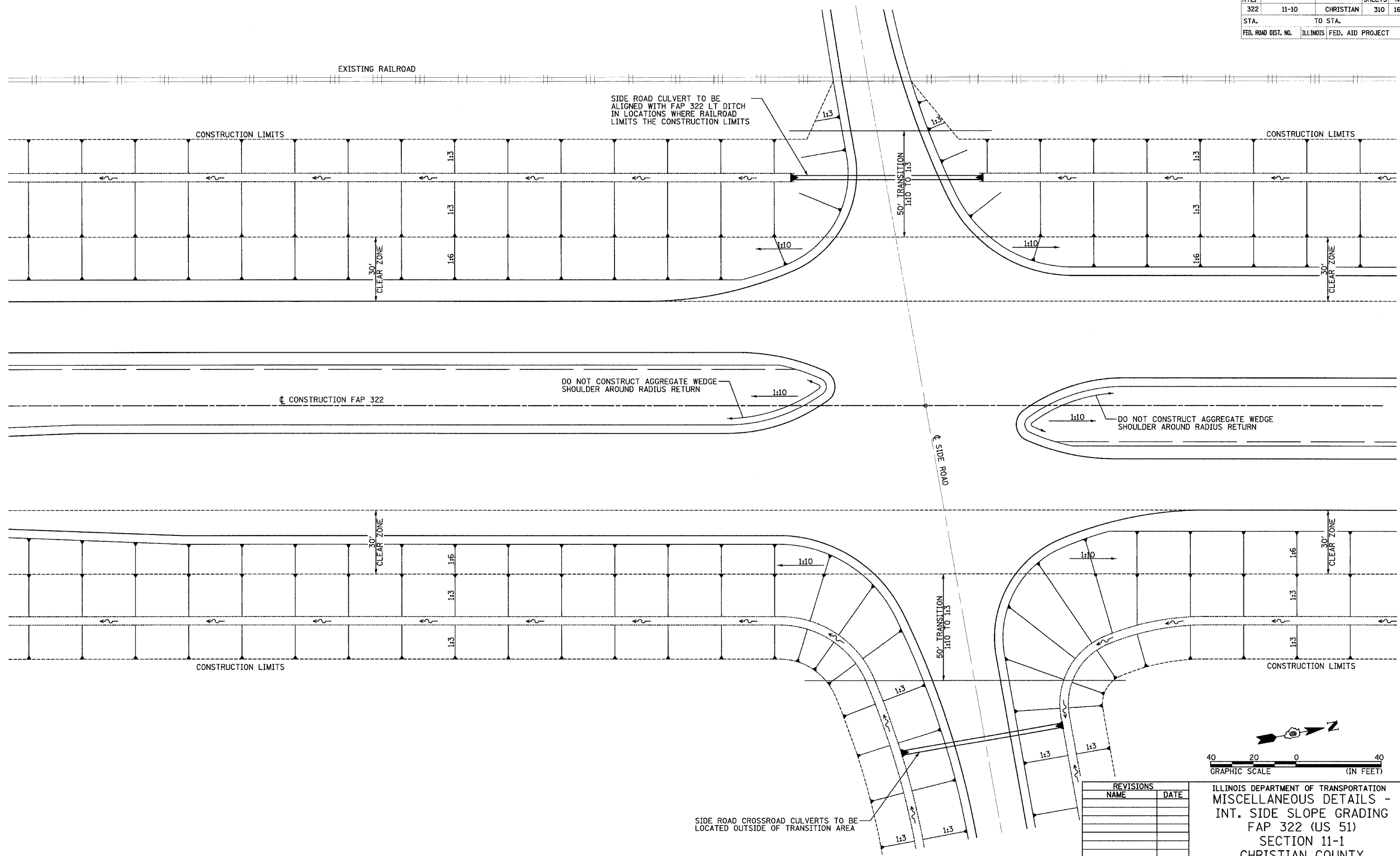

3/21/2005

p:\211\Task\0323\New-1\Figures\167.mxd

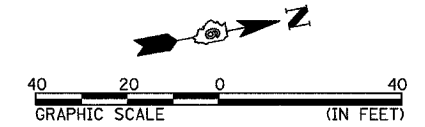

REVISIONS	
NAME	DATE

ILLINOIS DEPARTMENT OF TRANSPORTATION
 MISCELLANEOUS DETAILS -
 INT. SIDE SLOPE GRADING
 FAP 322 (US 51)
 SECTION 11-1
 CHRISTIAN COUNTY

SCALE: 1"=20'
 DATE: 3/18/05

DRAWN BY: BDJ
 CHECKED BY: SEB

F.A.P. RTE.	SECTION	COUNTY	TOTAL SHEETS	SHEET NO.
322	11-10	CHRISTIAN	310	168
STA.		TO STA.		
FED. ROAD DIST. NO.		ILLINOIS FED. AID PROJECT		

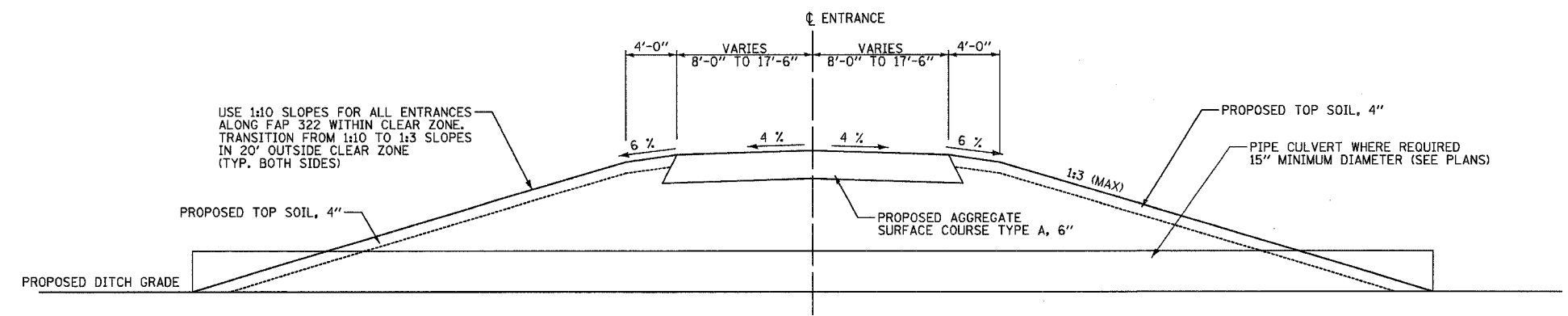

TYPICAL SECTION (PRIVATE / FIELD ENTRANCE)

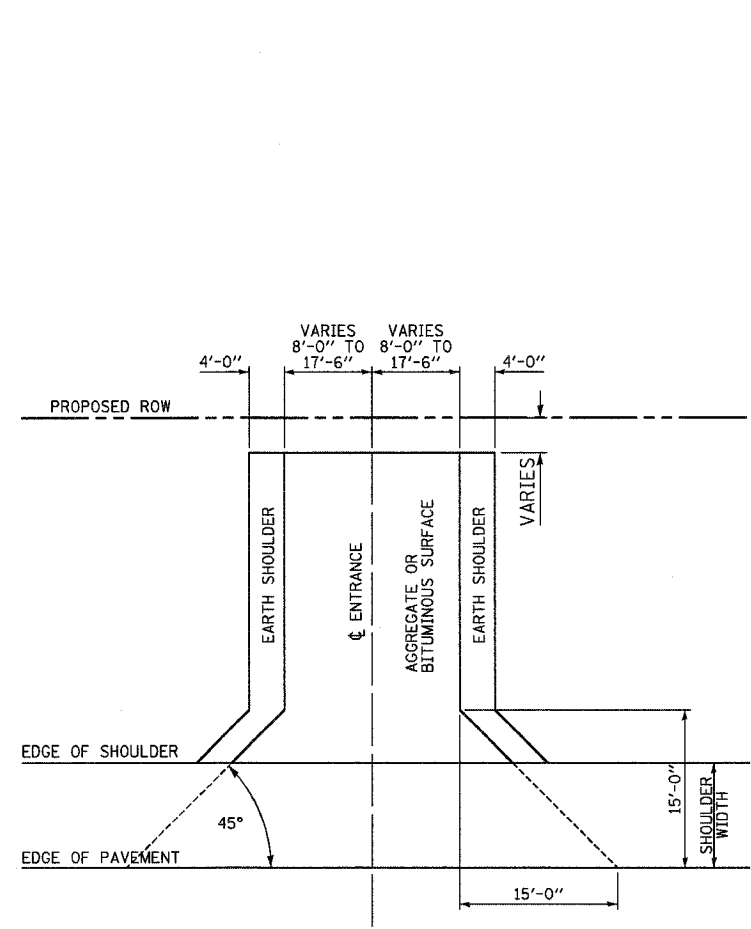

PRIVATE & FIELD ENTRANCE PLAN DETAIL SINGLE ENTRANCE

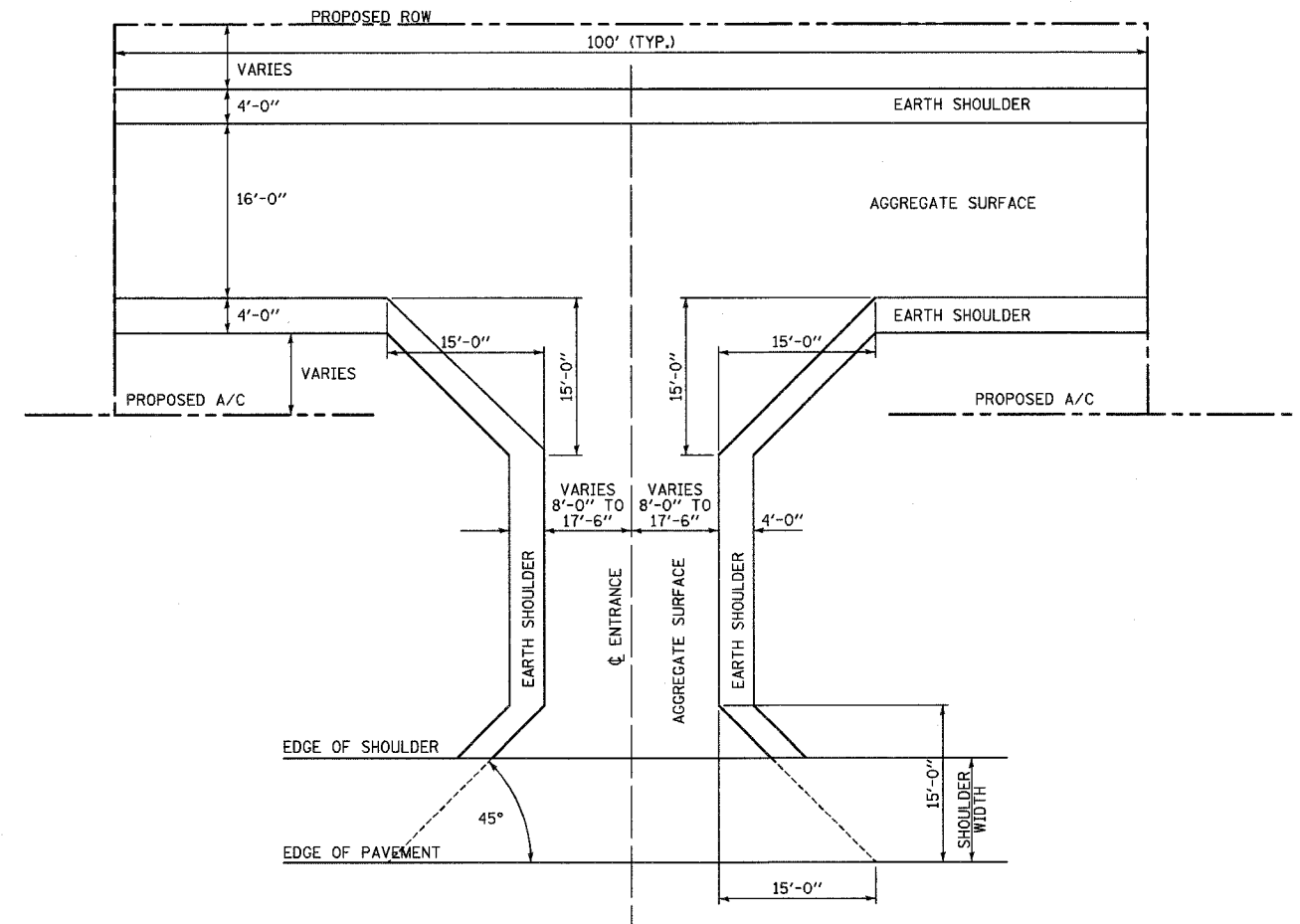

PRIVATE & FIELD ENTRANCE PLAN DETAIL DUAL ENTRANCE

PROPOSED FAP 322

REVISIONS	
NAME	DATE

ILLINOIS DEPARTMENT OF TRANSPORTATION
 MISCELLANEOUS DETAILS -
 ENTRANCES - EXPRESSWAY
 FAP 322 (US 51)
 SECTION 11-1
 CHRISTIAN COUNTY

SCALE: None DRAWN BY SEB
 DATE 3/21/05 CHECKED BY EBB

3/29/2005

\\s01\lana\B\B2020\pvc\hellana\168a\66.dwg

F.A.P. RTE.	SECTION	COUNTY	TOTAL SHEETS	SHEET NO.
322	11-10	CHRISTIAN	310	169
STA.		TO STA.		
FED. ROAD DIST. NO.		ILLINOIS FED. AID PROJECT		

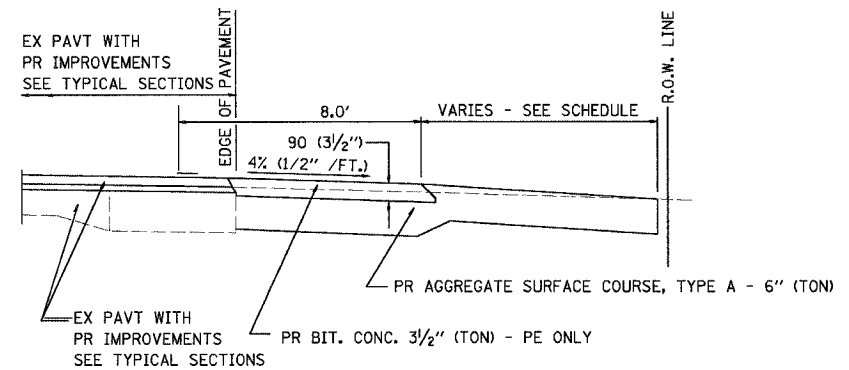

SECTION A-A FOR EX EARTH/AGGREGATE FE & PE

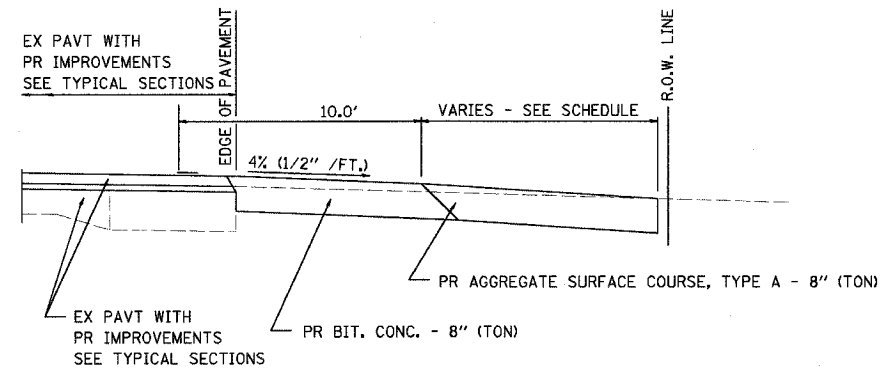

SECTION A-A FOR EX EARTH/AGGREGATE CE

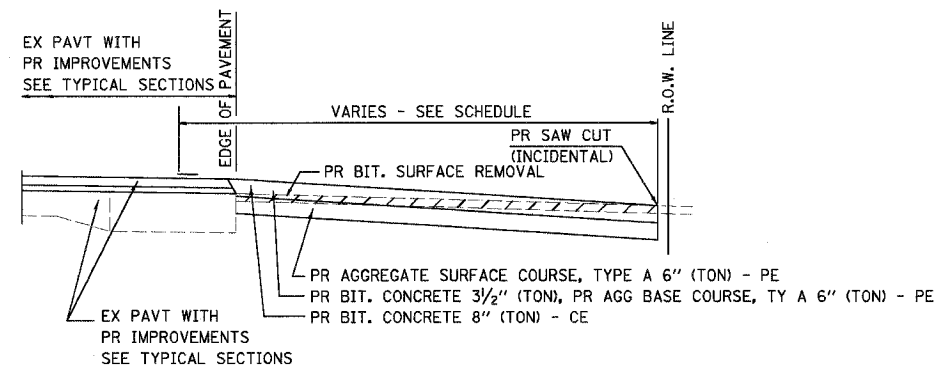

SECTION A-A FOR EX BITUMINOUS PE & CE

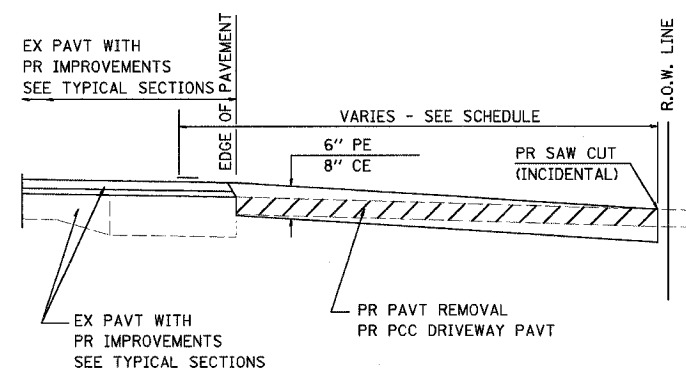

SECTION A-A FOR EX P.C. CONC. PE & CE

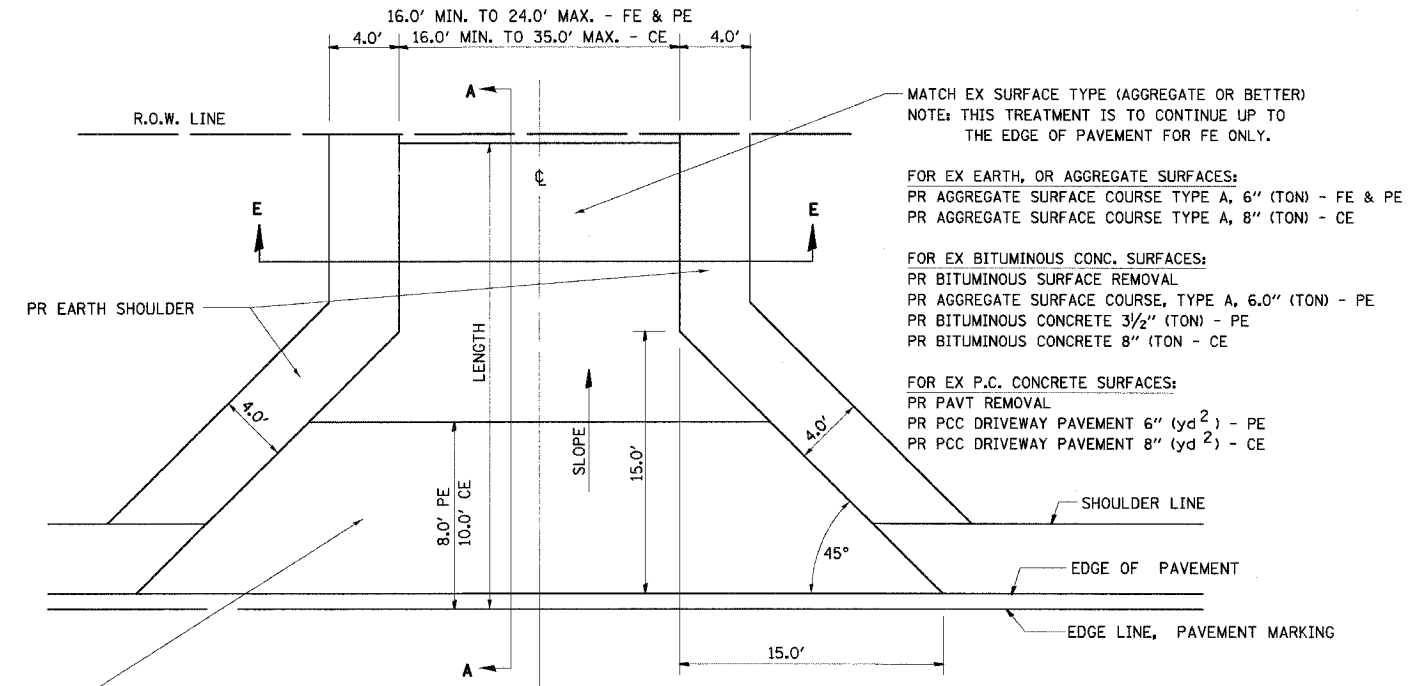

FOR EX EARTH, AGGREGATE, OR BITUMINOUS CONC SURFACES:
 PR BIT SURFACE REMOVAL (IF APPLICABLE)
 PR AGGREGATE SURFACE COURSE TYPE A 6" (TON) - FE
 PR AGGREGATE SURFACE COURSE TYPE A, 6" (TON) &
 PR BITUMINOUS CONCRETE 3 1/2" (TON) - PE
 PR BITUMINOUS CONCRETE 8" (TON) - CE

FOR P.C. CONCRETE SURFACES:
 PR PAVT REMOVAL
 PR PCC DRIVEWAY PAVT 6" (yd²) - PE
 PR PCC DRIVEWAY PAVT 8" (yd²) - CE

GENERAL NOTES:
 THE RESIDENT ENGINEER WILL DETERMINE THE EXACT TYPE OF IMPROVEMENT TO BE COMPLETED FOR ALL ENTRANCES, SIDEROADS AND MAILBOX TURNOUTS ON THIS PROJECT.

THE PLAN DETAILS AND SCHEDULES SHOULD BE USED AS A GUIDE FOR THE ENGINEER TO IMPLEMENT THE FINAL DESIGN. THE ENGINEER MAY DECIDE TO SALVAGE PORTIONS OF THE EXISTING ENTRANCE PAVEMENT STRUCTURE; THEREFORE, REDUCING PAY ITEM QUANTITIES. NO ADDITIONAL PAYMENT WILL BE ALLOWED FOR THIS REDUCTION IN QUANTITIES.

ANY WORK THE ENGINEER REQUIRES WHICH IS NOT COVERED BY A PAY ITEM CONTAINED IN THE PLANS WILL BE PAID FOR IN ACCORDANCE WITH ARTICLE 109.04 OF THE STANDARD SPECIFICATIONS.

BITUMINOUS CONCRETE REQUIRED TO CONSTRUCT THE ENTRANCES SHALL BE IN ACCORDANCE WITH THE APPLICABLE PORTIONS OF SECTION 406 AND 408 OF THE STANDARD SPECIFICATIONS AND AS DIRECTED BY THE ENGINEER.

WHEN THE BITUMINOUS CONCRETE PROPOSED FOR THE IMPROVEMENT IS THICKER THAN 3 INCHES AND REQUIRE PLACEMENT IN MORE THAN ONE LIFT. THE BOTTOM LIFT(S) SHALL MEET THE REQUIREMENTS OF BITUMINOUS BASE COURSE IN SECTION 406 OF THE STANDARD SPECIFICATIONS AND THE TOP LIFT OF 2 INCHES SHALL MEET THE REQUIREMENTS OF BITUMINOUS CONCRETE SURFACE COURSE, MIXTURE C, CLASS I, TYPE 2 OF SECTION 406 OF THE STANDARD SPECIFICATIONS.

THIS WORK WILL BE PAID FOR AT THE CONTRACT UNIT PRICE PER METRIC TON (TON) FOR "INCIDENTAL BITUMINOUS SURFACING" WHICH SHALL INCLUDE ALL MATERIALS, EQUIPMENT, AND LABOR INVOLVED.

NOTE 1: WIDTH OF ENTRANCE MAY BE INCREASED AT THE PIPE CULVERT DUE TO THE DITCHLINE BEING LOCATED IN THE ENTRANCE FLARE AREA.

SIDE ROADS

REVISIONS	NAME	DATE

ILLINOIS DEPARTMENT OF TRANSPORTATION
 MISCELLANEOUS DETAILS -
 ENTRANCES - SIDE ROADS
 FAP 322 (US 51)
 SECTION 11-1
 CHRISTIAN COUNTY

SCALE: NONE DRAWN BY SEB
 DATE 3/21/05 CHECKED BY EBB

3/21/05

F.A. RTE.	SECTION	COUNTY	TOTAL SHEETS	SHEET NO.
322	11-10	CHRISTIAN	310	171
STA.		TO STA.		
FED. ROAD DIST. NO.		ILLINOIS FED. AID PROJECT		

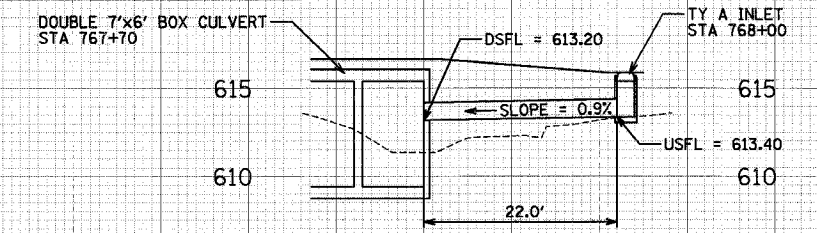
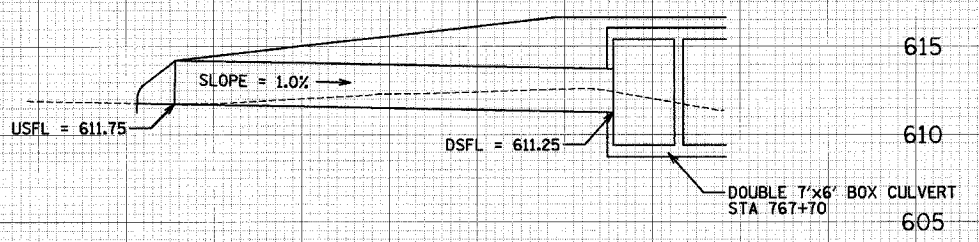
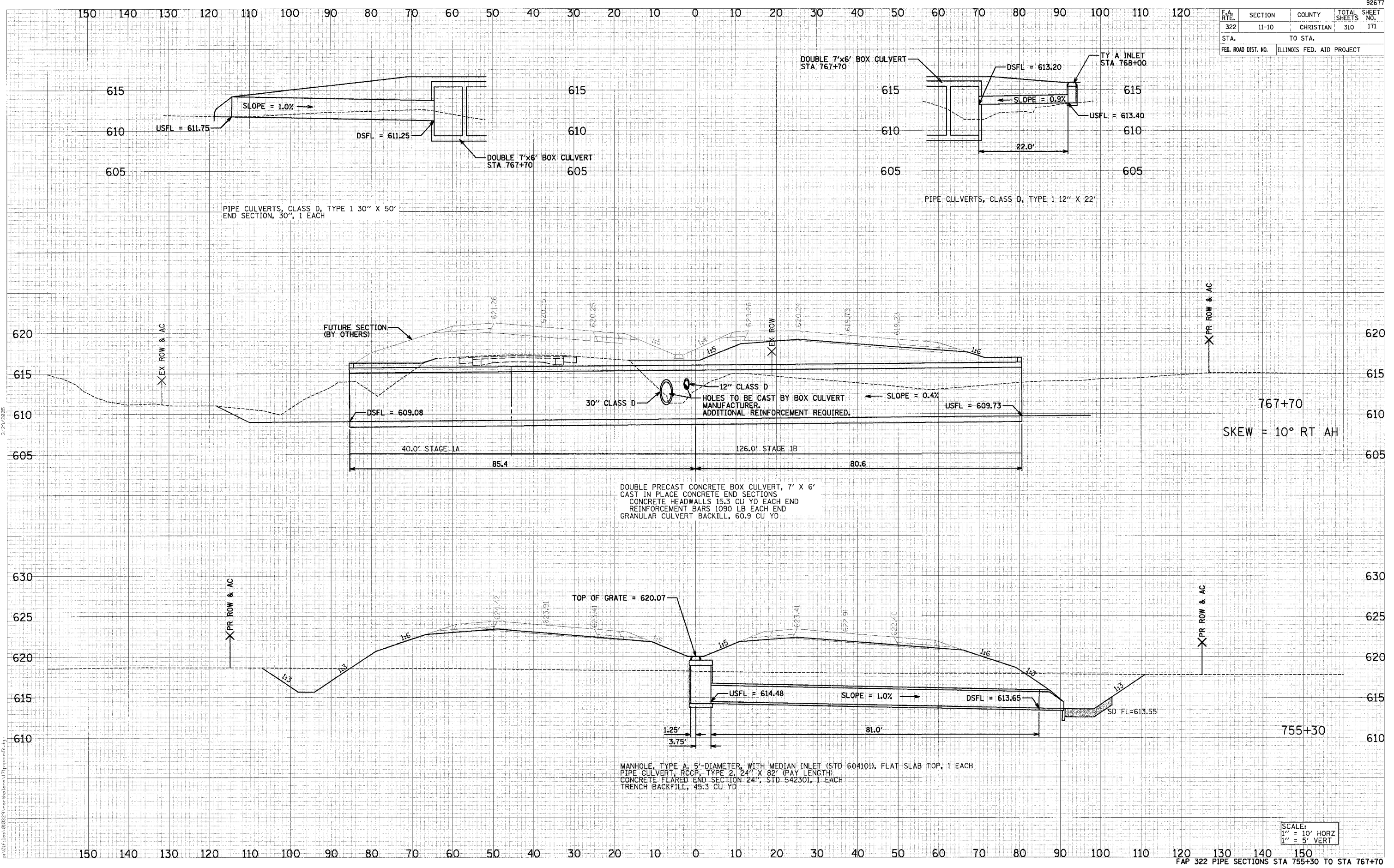

PIPE CULVERTS, CLASS D, TYPE 1 30" X 50'
END SECTION, 30", 1 EACH

PIPE CULVERTS, CLASS D, TYPE 1 12" X 22'

12" CLASS D HOLES TO BE CAST BY BOX CULVERT MANUFACTURER. ADDITIONAL REINFORCEMENT REQUIRED.

DOUBLE PRECAST CONCRETE BOX CULVERT, 7' X 6'
CAST IN PLACE CONCRETE END SECTIONS
CONCRETE HEADWALLS 15.3 CU YD EACH END
REINFORCEMENT BARS 1090 LB EACH END
GRANULAR CULVERT BACKFILL, 60.9 CU YD

MANHOLE, TYPE A, 5'-DIAMETER, WITH MEDIAN INLET (STD 604101), FLAT SLAB TOP, 1 EACH
PIPE CULVERT, RCCP, TYPE 2, 24" X 82' (PAY LENGTH)
CONCRETE FLARED END SECTION 24", STD 542301, 1 EACH
TRENCH BACKFILL, 45.3 CU YD

767+70
SKEW = 10° RT AH

755+30

SCALE:
1" = 10' HORZ
1" = 5' VERT

DATE	
BY	
NO.	
FINAL SURVEY	
SKIPPED SURVEY	
NOTED BOOK	
TEMPLATE	
AREAS CHECKED	

DATE	
BY	
NO.	
ORIGINAL SURVEY	
SKIPPED SURVEY	
NOTED BOOK	
TEMPLATE	
AREAS CHECKED	

F.A. RITE	SECTION	COUNTY	TOTAL SHEET NO.
322	11-10	CHRISTIAN	310
STA.	TO STA.		
FED. ROAD DIST. NO.	ILLINOIS	FED. AID PROJECT	

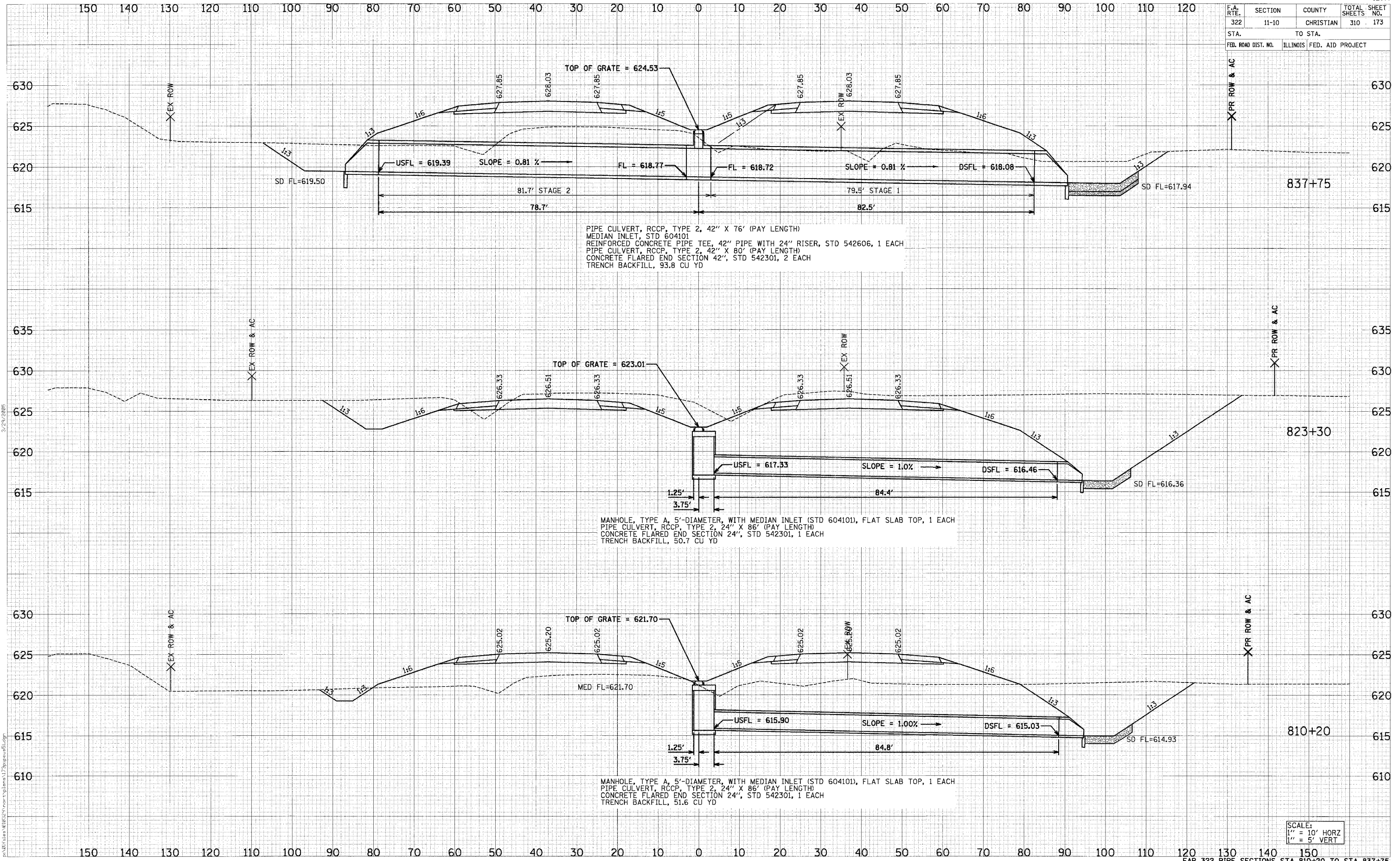

PIPE CULVERT, RCCP, TYPE 2, 42" X 76' (PAY LENGTH)
 MEDIAN INLET, STD 604101
 REINFORCED CONCRETE PIPE TEE, 42" PIPE WITH 24" RISER, STD 542606, 1 EACH
 PIPE CULVERT, RCCP, TYPE 2, 42" X 80' (PAY LENGTH)
 CONCRETE FLARED END SECTION 42", STD 542301, 2 EACH
 TRENCH BACKFILL, 93.8 CU YD

MANHOLE, TYPE A, 5'-DIAMETER, WITH MEDIAN INLET (STD 604101), FLAT SLAB TOP, 1 EACH
 PIPE CULVERT, RCCP, TYPE 2, 24" X 86' (PAY LENGTH)
 CONCRETE FLARED END SECTION 24", STD 542301, 1 EACH
 TRENCH BACKFILL, 50.7 CU YD

MANHOLE, TYPE A, 5'-DIAMETER, WITH MEDIAN INLET (STD 604101), FLAT SLAB TOP, 1 EACH
 PIPE CULVERT, RCCP, TYPE 2, 24" X 86' (PAY LENGTH)
 CONCRETE FLARED END SECTION 24", STD 542301, 1 EACH
 TRENCH BACKFILL, 51.6 CU YD

SCALE:
 1" = 10' HORZ
 1" = 5' VERT

DATE
 BY
 SURVEY
 TEMPLATE
 NOTE BOOK
 AREAS CHECKED

DATE
 BY
 SURVEY
 TEMPLATE
 NOTE BOOK
 AREAS CHECKED

DATE
 BY
 SURVEY
 TEMPLATE
 NOTE BOOK
 AREAS CHECKED

F.A. RTE.	SECTION	COUNTY	TOTAL SHEETS	SHEET NO.
322	11-10	CHRISTIAN	310	175
STA.	TO STA.			
FED. ROAD DIST. NO.	ILLINOIS FED. AID PROJECT			

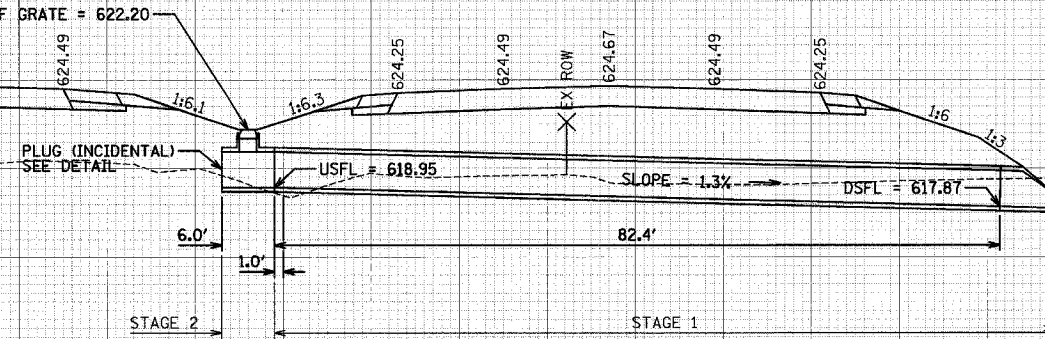
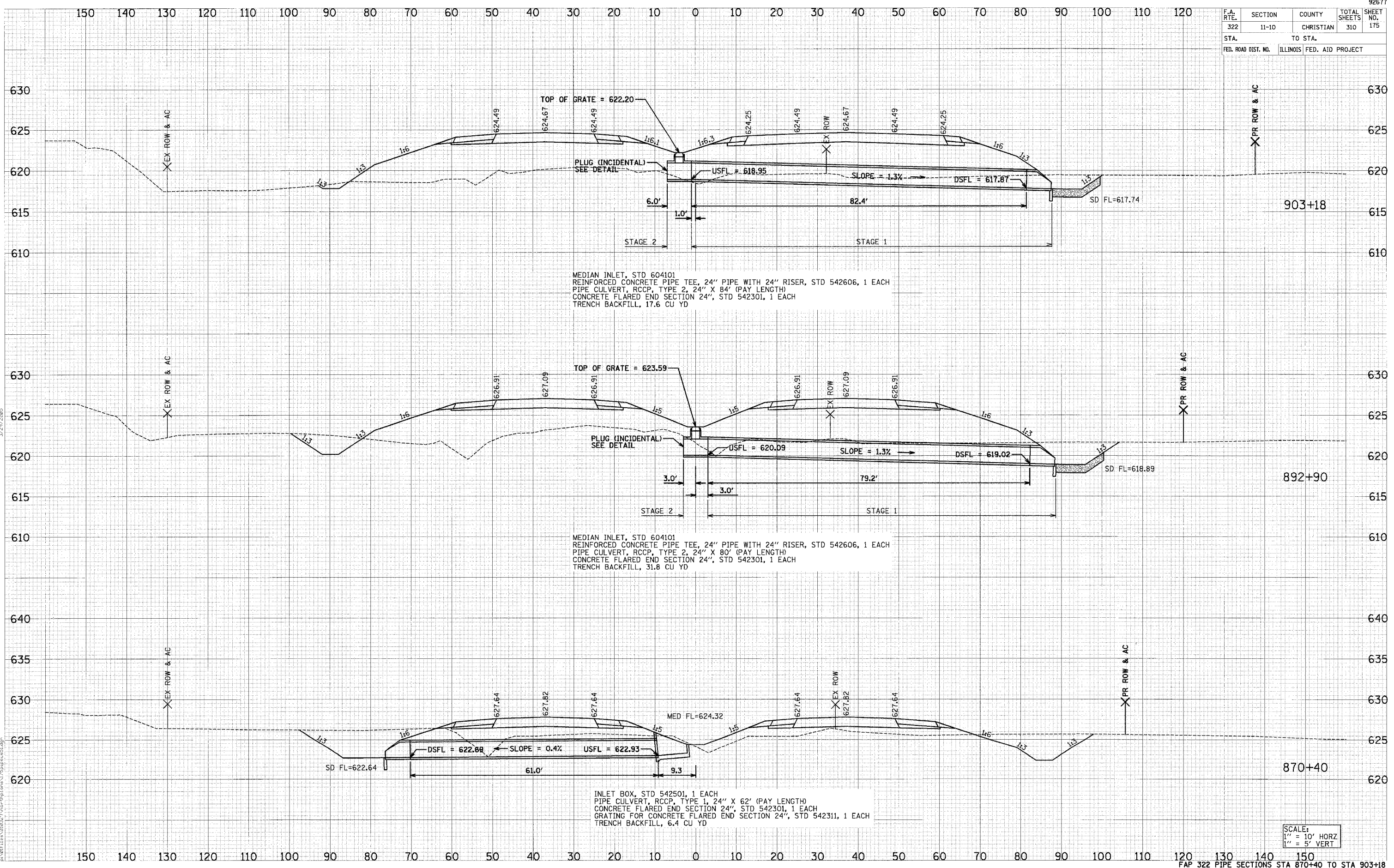

MEDIAN INLET, STD 604101
 REINFORCED CONCRETE PIPE TEE, 24" PIPE WITH 24" RISER, STD 542606, 1 EACH
 PIPE CULVERT, RCCP, TYPE 2, 24" X 84" (PAY LENGTH)
 CONCRETE FLARED END SECTION 24", STD 542301, 1 EACH
 TRENCH BACKFILL, 17.6 CU YD

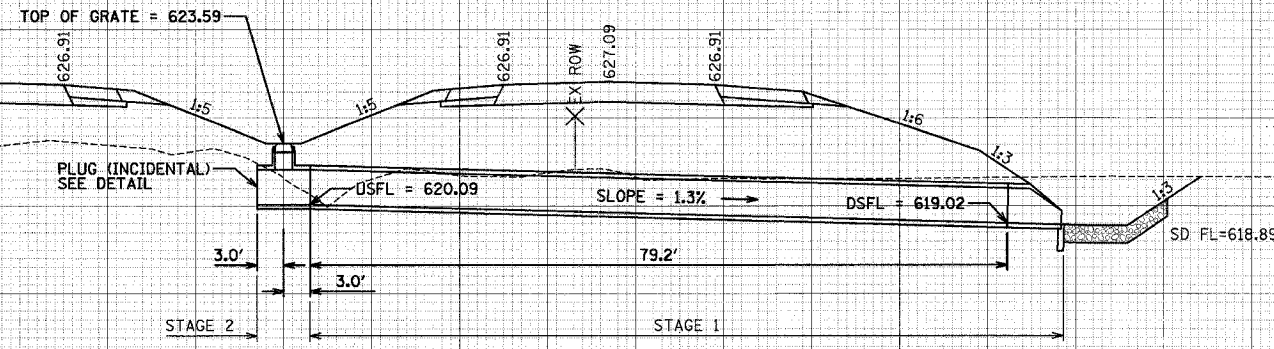

MEDIAN INLET, STD 604101
 REINFORCED CONCRETE PIPE TEE, 24" PIPE WITH 24" RISER, STD 542606, 1 EACH
 PIPE CULVERT, RCCP, TYPE 2, 24" X 80" (PAY LENGTH)
 CONCRETE FLARED END SECTION 24", STD 542301, 1 EACH
 TRENCH BACKFILL, 31.8 CU YD

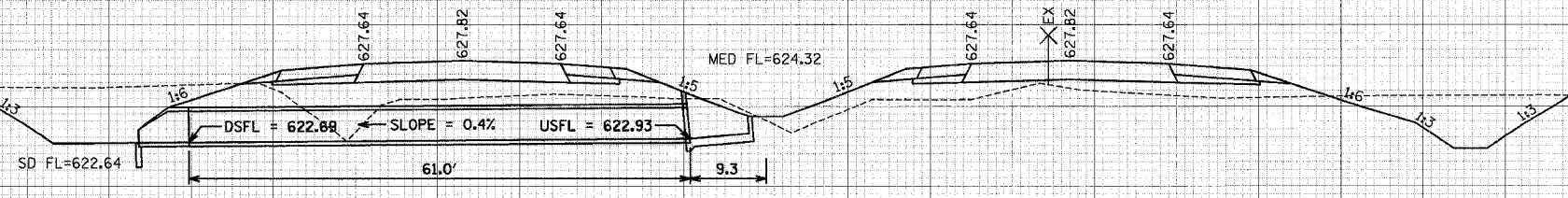

INLET BOX, STD 542501, 1 EACH
 PIPE CULVERT, RCCP, TYPE 1, 24" X 62' (PAY LENGTH)
 CONCRETE FLARED END SECTION 24", STD 542301, 1 EACH
 GRATING FOR CONCRETE FLARED END SECTION 24", STD 542311, 1 EACH
 TRENCH BACKFILL, 6.4 CU YD

SCALE:
 1" = 10' HORZ
 1" = 5' VERT

DATE: _____
 BY: _____
 SUPERVISOR: _____
 CHECKED: _____
 NO. _____

DATE: _____
 BY: _____
 SUPERVISOR: _____
 CHECKED: _____
 NO. _____

DATE: _____
 BY: _____
 SUPERVISOR: _____
 CHECKED: _____
 NO. _____

F.A. RTE.	SECTION	COUNTY	TOTAL SHEETS	SHEET NO.
322	11-10	CHRISTIAN	310	178
STA.		TO STA.		
FED. ROAD DIST. NO.		ILLINOIS FED. AID PROJECT		

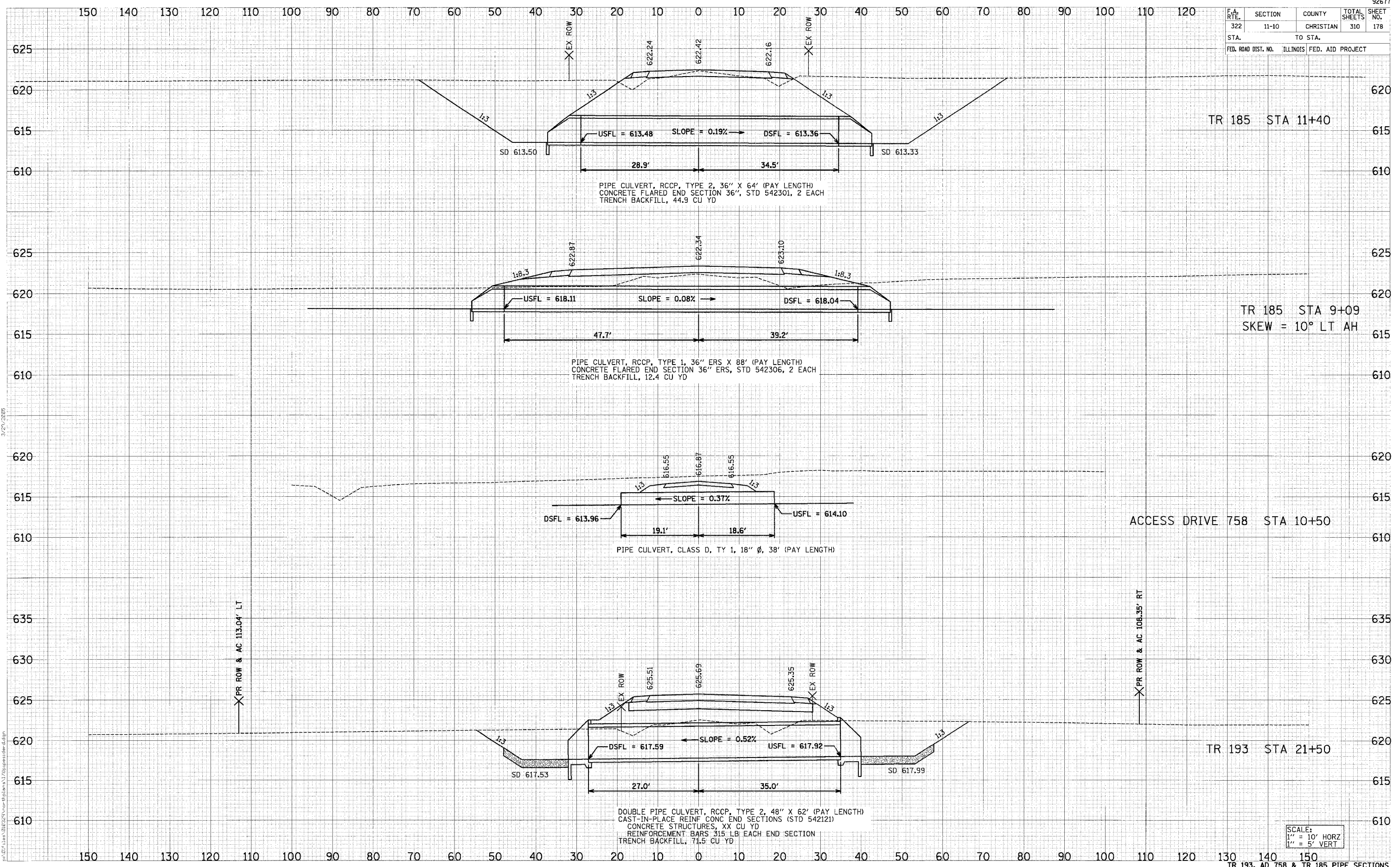

TR 185 STA 11+40

TR 185 STA 9+09
SKEW = 10° LT AH

ACCESS DRIVE 758 STA 10+50

TR 193 STA 21+50

SCALE:
1" = 10' HORZ
1" = 5' VERT

DATE	
BY	
ORIGINAL SURVEY	
NOTE BOOK	
TEMP. PLAT	
AREAS CHECKED	

DATE	
BY	
ORIGINAL SURVEY	
NOTE BOOK	
TEMP. PLAT	
AREAS CHECKED	

D:\01-Han\01025\work\p100\1\03\p1001.dwg

F.A. RTE.	SECTION	COUNTY	TOTAL SHEETS	SHEET NO.
322	11-10	CHRISTIAN	310	179
STA.		TO STA.		
FED. ROAD DIST. NO.		ILLINOIS	FED. AID PROJECT	

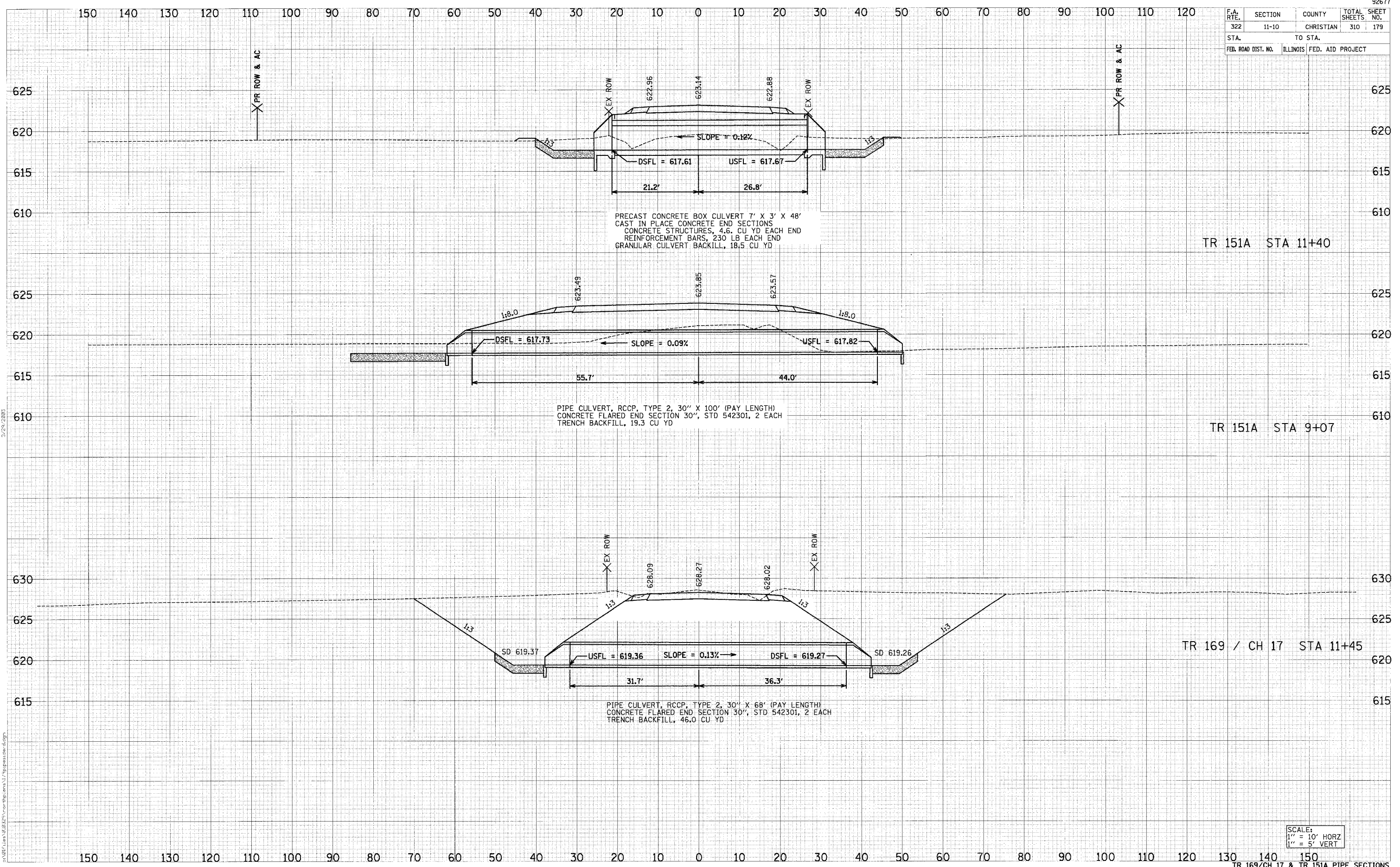

DATE	
BY	
FINAL SURVEY	
SURVEY	
NOTE BOOK	
TEMPLATE	
AREAS	
CHECKED	

DATE	
BY	
ORIGINAL SURVEY	
SURVEY	
NOTE BOOK	
TEMPLATE	
AREAS	
CHECKED	

SCALE:
 1" = 10' HORIZ
 1" = 5' VERT

F.A. RTE.	SECTION	COUNTY	TOTAL SHEETS	SHEET NO.
322	11-10	CHRISTIAN	310	180
STA.		TO STA.		
FED. ROAD DIST. NO.		ILLINOIS FED. AID PROJECT		

DATE	BY
DATE	BY
DATE	BY
DATE	BY
DATE	BY

DATE	BY
DATE	BY
DATE	BY
DATE	BY
DATE	BY

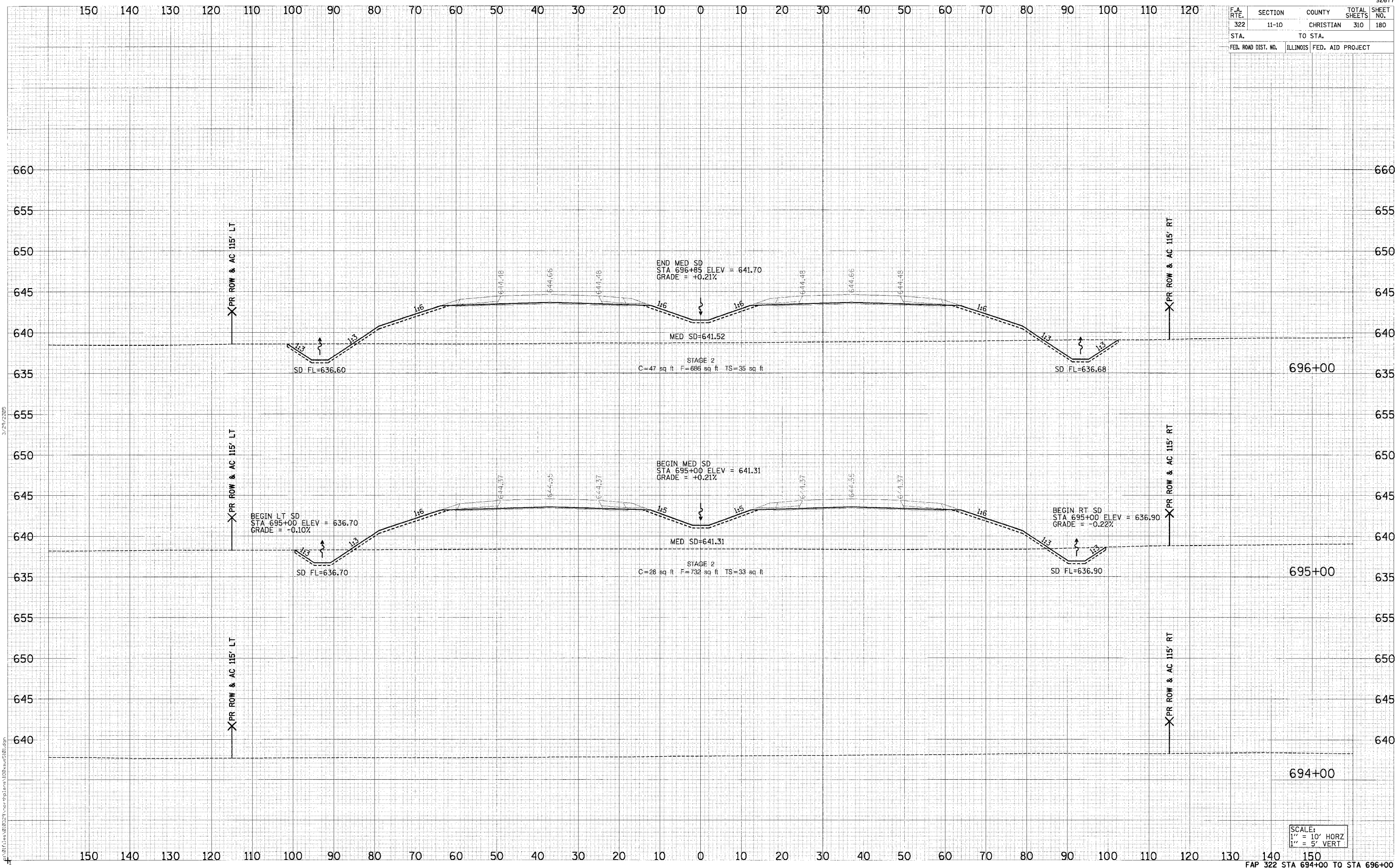

SCALE:
 1" = 10' HORIZ
 1" = 5' VERT

F.A. RTE.	SECTION	COUNTY	TOTAL SHEET NO.
322	11-10	CHRISTIAN	310 184
STA.		TO STA.	
FED. ROAD DIST. NO.		ILLINOIS FED. AID PROJECT	

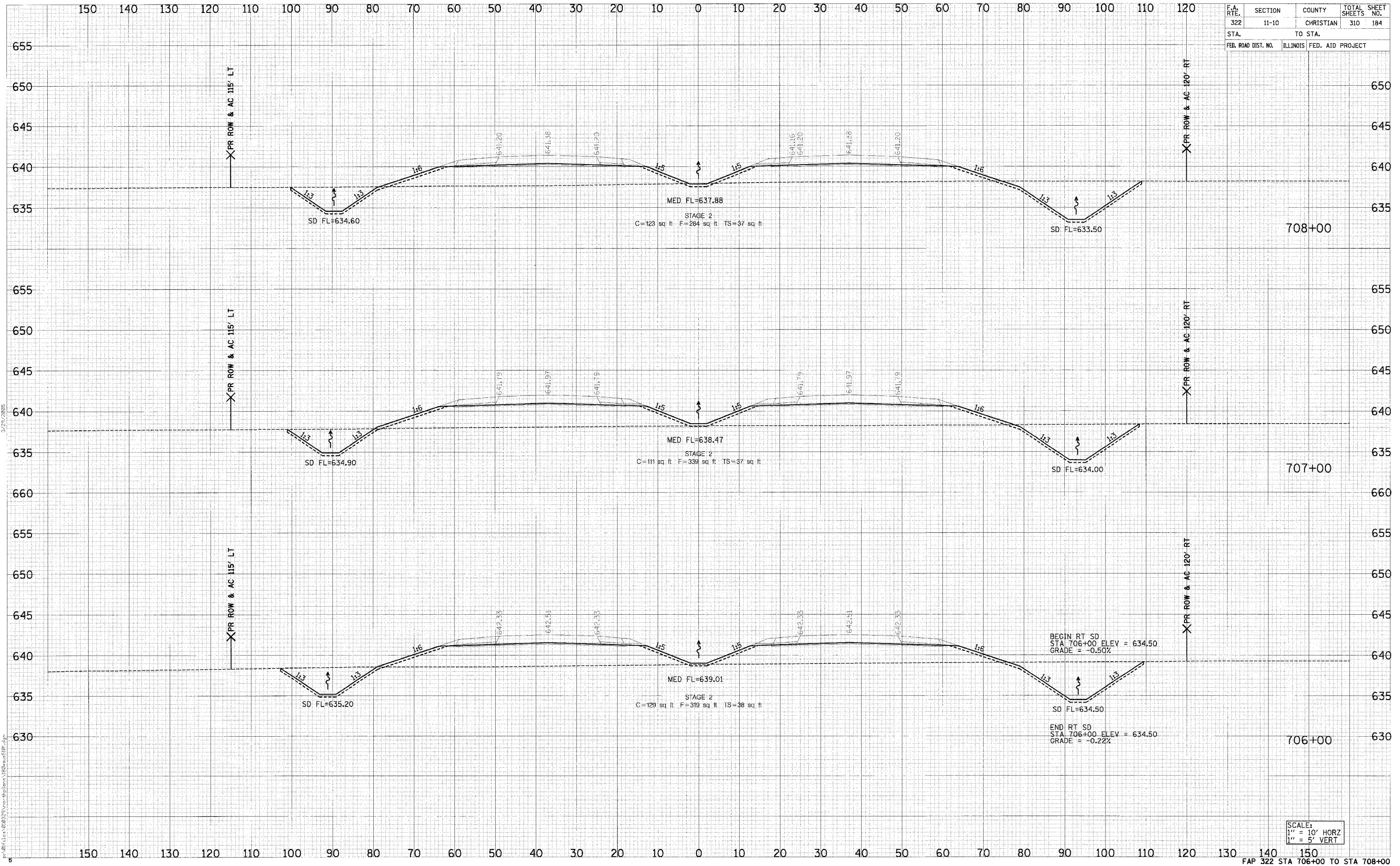

DATE: _____
 BY: _____
 CHECKED: _____
 SURVEYED: _____
 PLANNED: _____
 TEMPLATE: _____
 AREAS: _____
 AREAS CHECKED: _____

DATE: _____
 BY: _____
 CHECKED: _____
 ORIGINAL SURVEY: _____
 PLANNED: _____
 TEMPLATE: _____
 AREAS: _____
 AREAS CHECKED: _____

SCALE:
 1" = 10' HORZ
 1" = 5' VERT

F.A. RTE.	SECTION	COUNTY	TOTAL SHEETS	SHEET NO.
322	11-10	CHRISTIAN	310	185
STA.		TO STA.		
FED. ROAD DIST. NO.		ILLINOIS	FED. AID PROJECT	

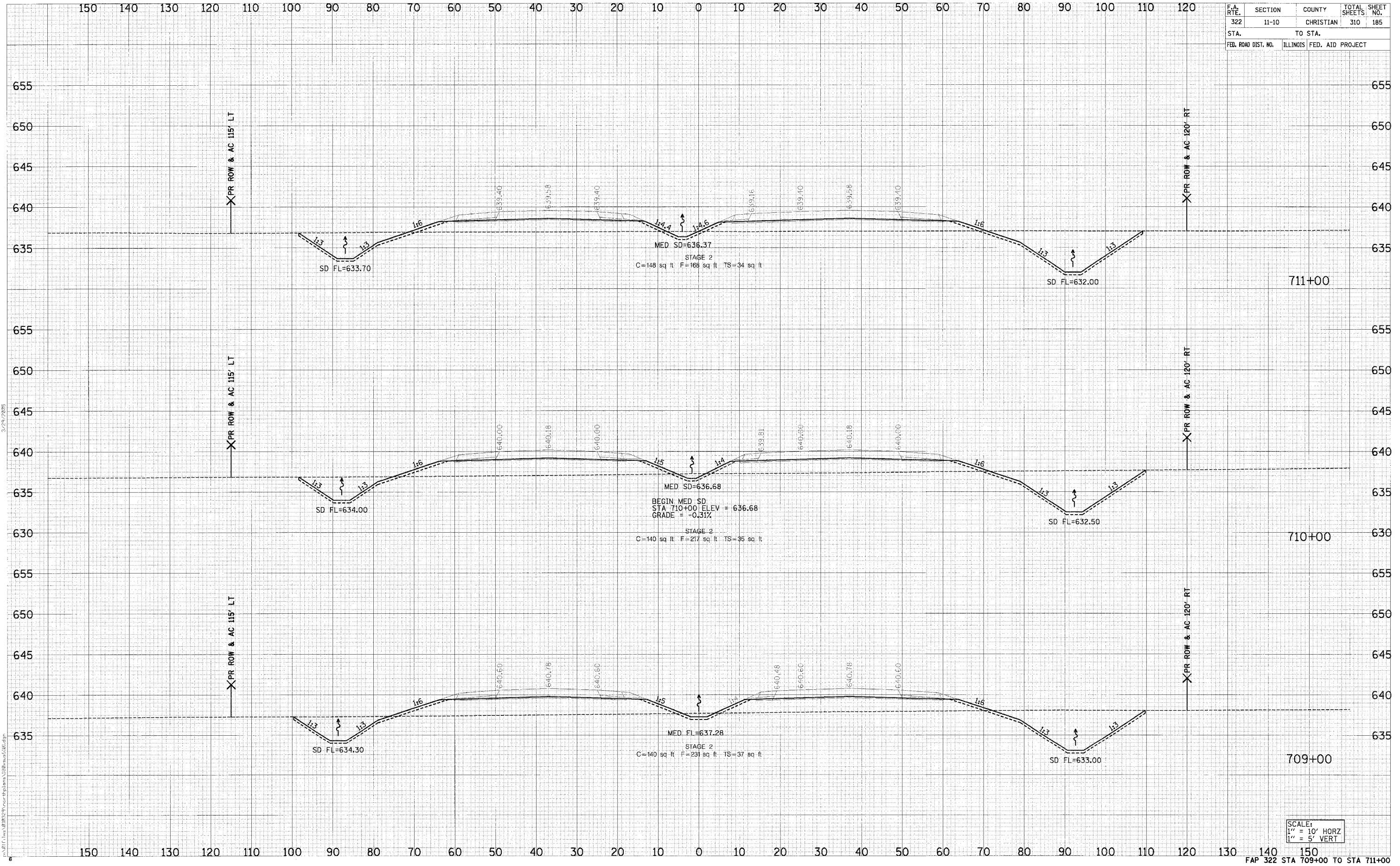

DATE	
BY	
REVIEWED	
DATE	
BY	
NO. OF SHEETS	
NO. OF BOOKS	
NO. OF PLATES	
NO. OF AREAS	
NO. OF CHECKS	

DATE	
BY	
REVIEWED	
DATE	
BY	
NO. OF SHEETS	
NO. OF BOOKS	
NO. OF PLATES	
NO. OF AREAS	
NO. OF CHECKS	

SCALE:
 1" = 10' HORZ
 1" = 5' VERT

F.A. FILE NO.	SECTION	COUNTY	TOTAL SHEETS	SHEET NO.
322	11-10	CHRISTIAN	310	187
STA.		TO STA.		
FED. ROAD DIST. NO.		ILLINOIS FED. AID PROJECT		

DATE	BY
DATE	BY
DATE	BY

DATE	BY
DATE	BY
DATE	BY

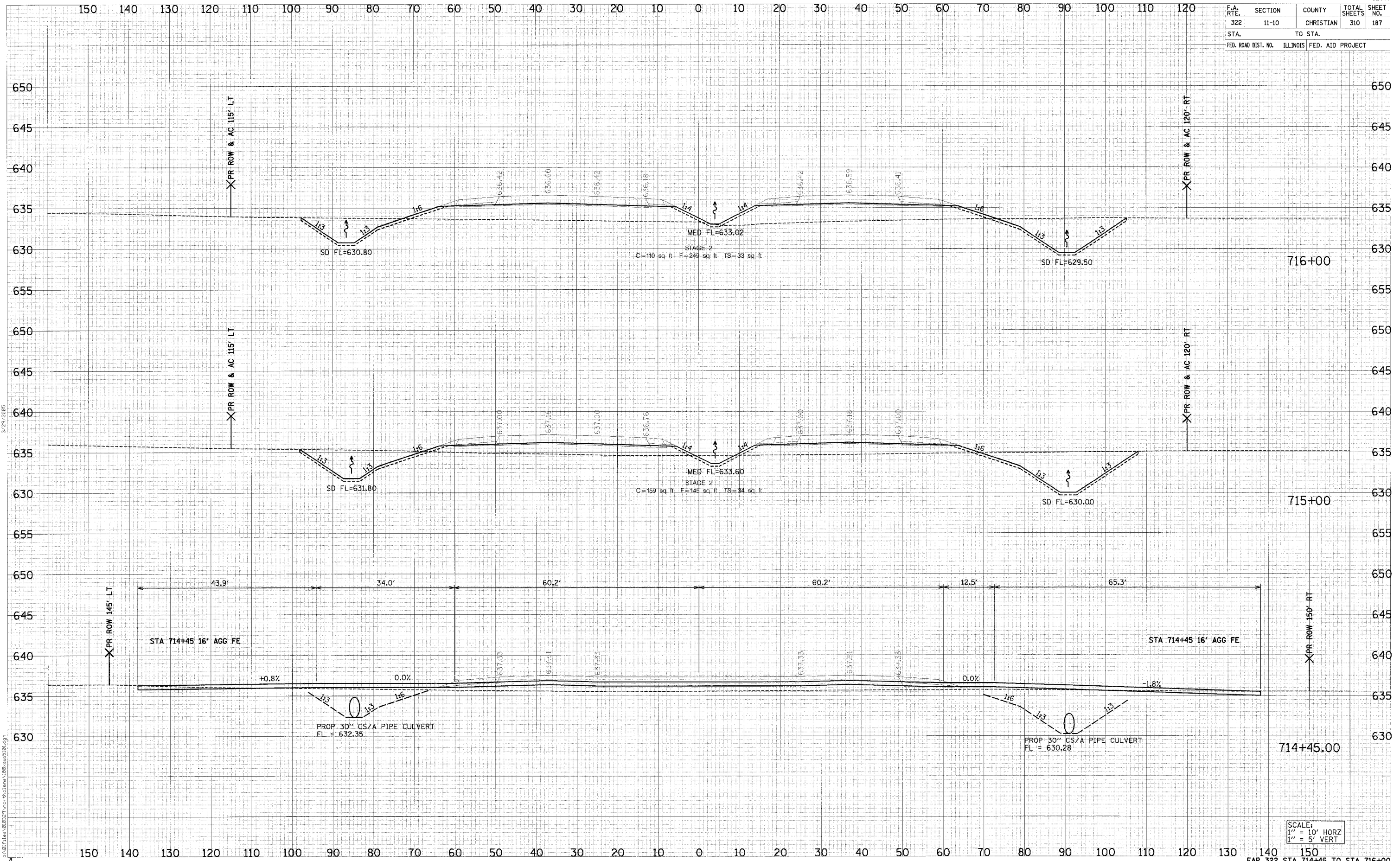

SCALE:
1" = 10' HORIZ
1" = 5' VERT

F.A. RTE.	SECTION	COUNTY	TOTAL SHEETS	SHEET NO.
322	11-10	CHRISTIAN	310	189
STA.		TO STA.		
FED. ROAD DIST. NO.		ILLINOIS FED. AID PROJECT		

DATE	BY
DATE	BY
DATE	BY
DATE	BY

DATE	BY
DATE	BY
DATE	BY
DATE	BY

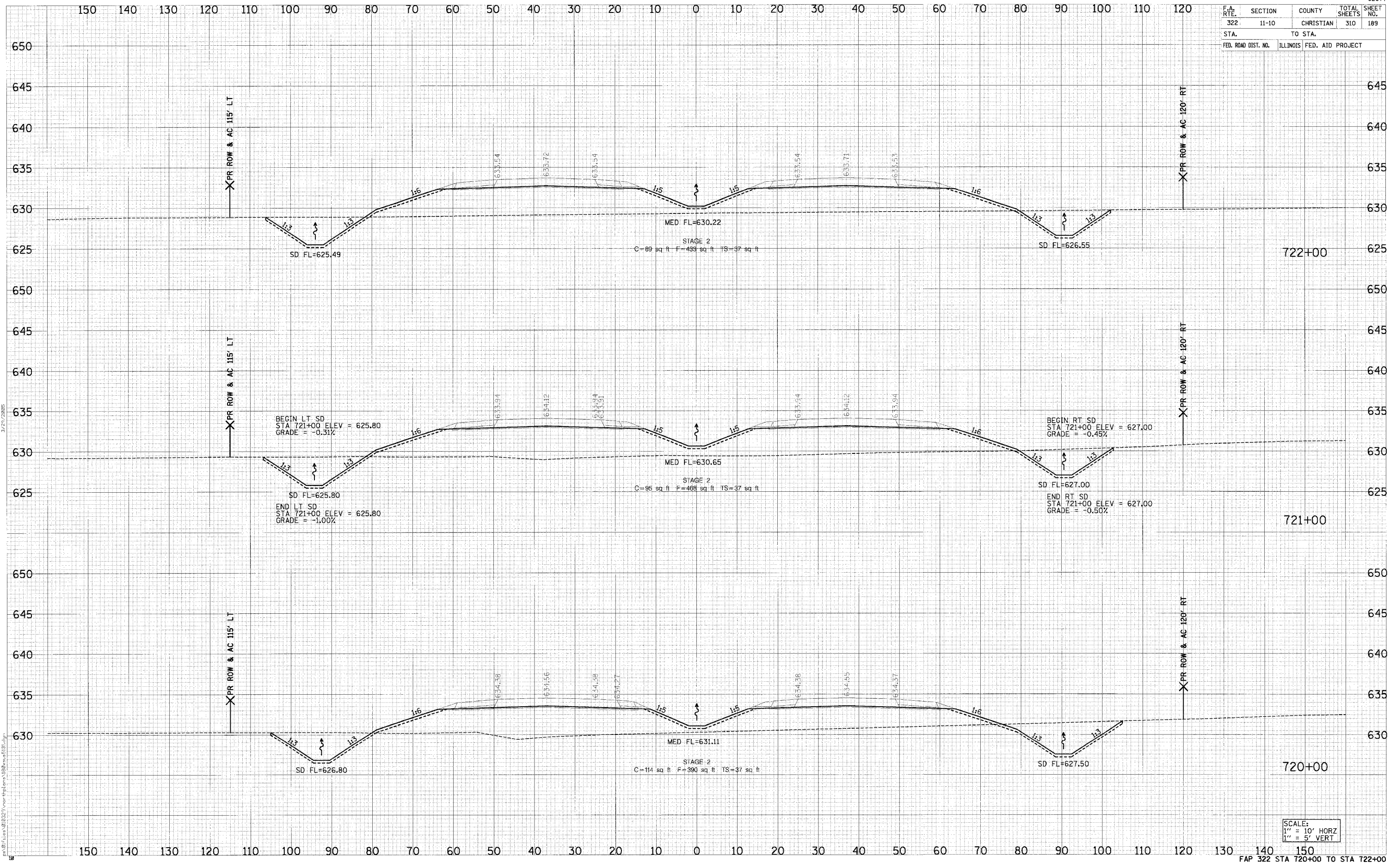

SCALE:
 1" = 10' HORZ
 1" = 5' VERT

F.A. RTE.	SECTION	COUNTY	TOTAL SHEETS	SHEET NO.
322	11-10	CHRISTIAN	310	190
STA.		TO STA.		
FED. ROAD DIST. NO.		ILLINOIS FED. AID PROJECT		

FINAL SURVEY	BY	DATE
SUBMITTED		
TEMPLATE		
NOTE BOOK		
AREAS CHECKED		
NO.		

ORIGINAL SURVEY	BY	DATE
SUBMITTED		
TEMPLATE		
NOTE BOOK		
AREAS CHECKED		
NO.		

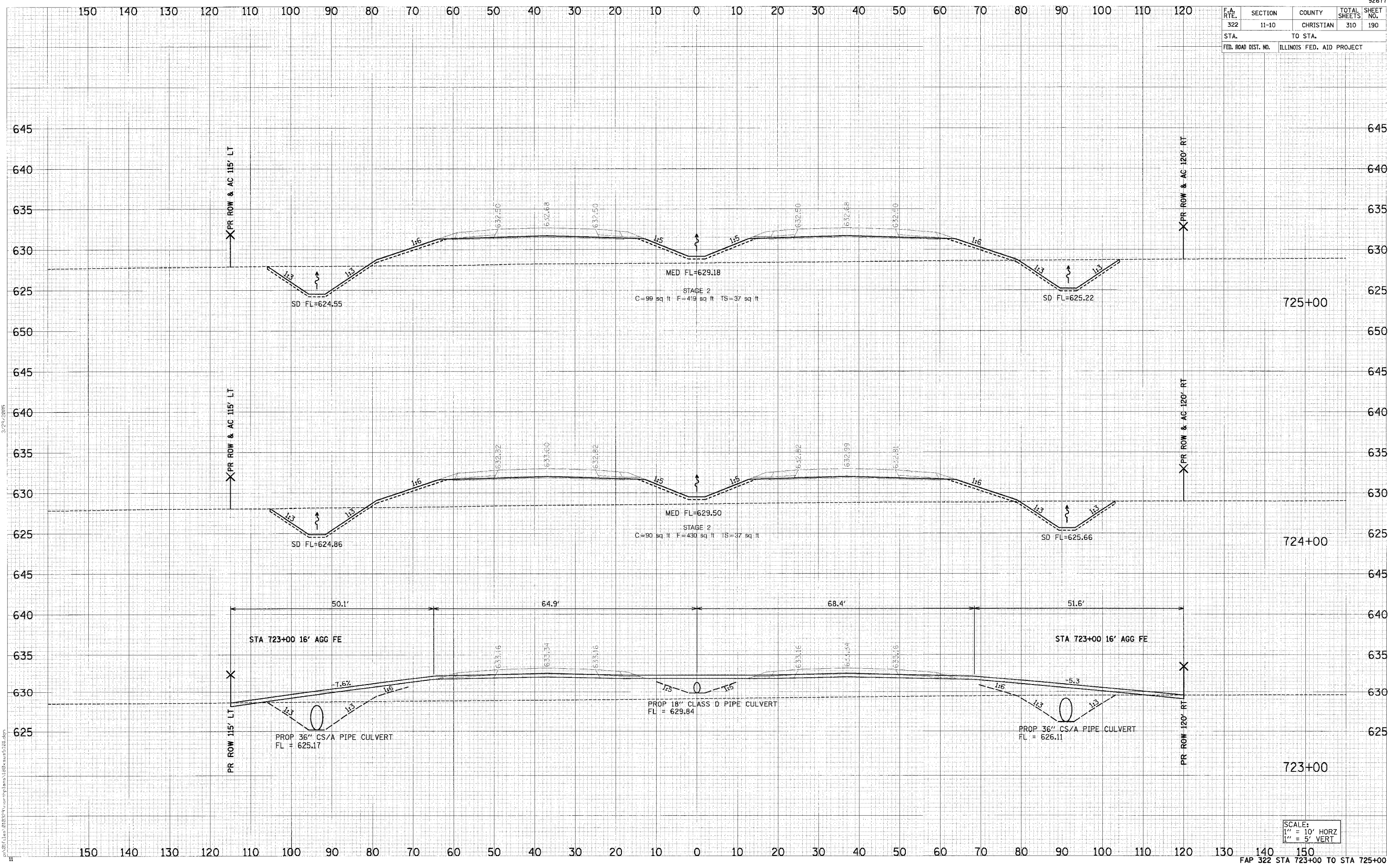

SCALE:
 1" = 10' HORZ
 1" = 5' VERT

F.A. RTE.	SECTION	COUNTY	TOTAL SHEETS	SHEET NO.
322	11-10	CHRISTIAN	310	192
STA.		TO STA.		
FED. ROAD DIST. NO.		ILLINOIS FED. AID PROJECT		

DATE	
BY	
FINAL SURVEY	
TEMPLATE	
NOTE BOOK	
AREAS CHECKED	
NO.	

DATE	
BY	
ORIGINAL SURVEY	
TEMPLATE	
NOTE BOOK	
AREAS CHECKED	
NO.	

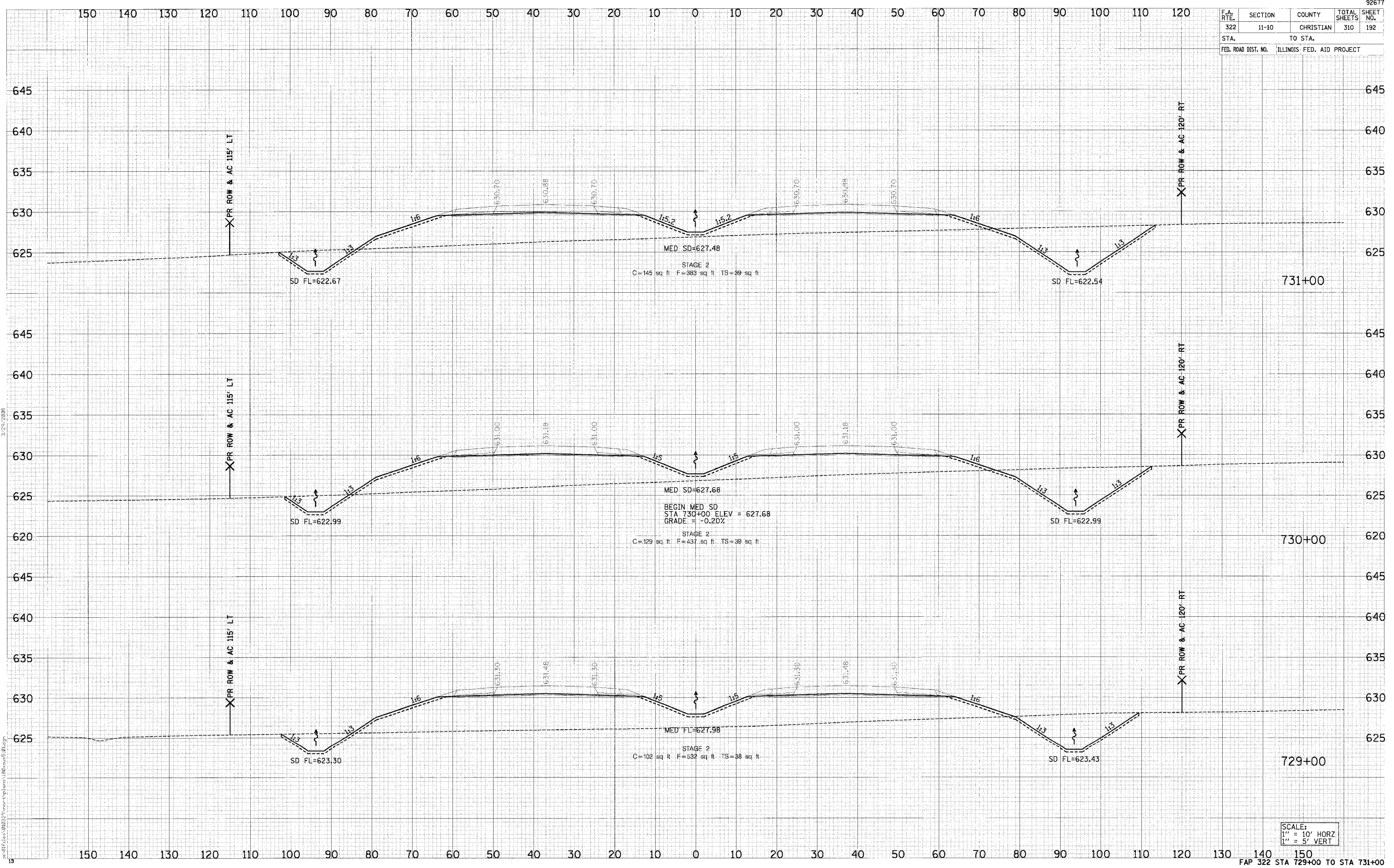

SCALE:
 1" = 10' HORZ
 1" = 5' VERT

F.A. RTE.	SECTION	COUNTY	TOTAL SHEETS	SHEET NO.
322	11-10	CHRISTIAN	310	194
STA.		TO STA.		
FED. ROAD DIST. NO.		ILLINOIS FED. AID PROJECT		

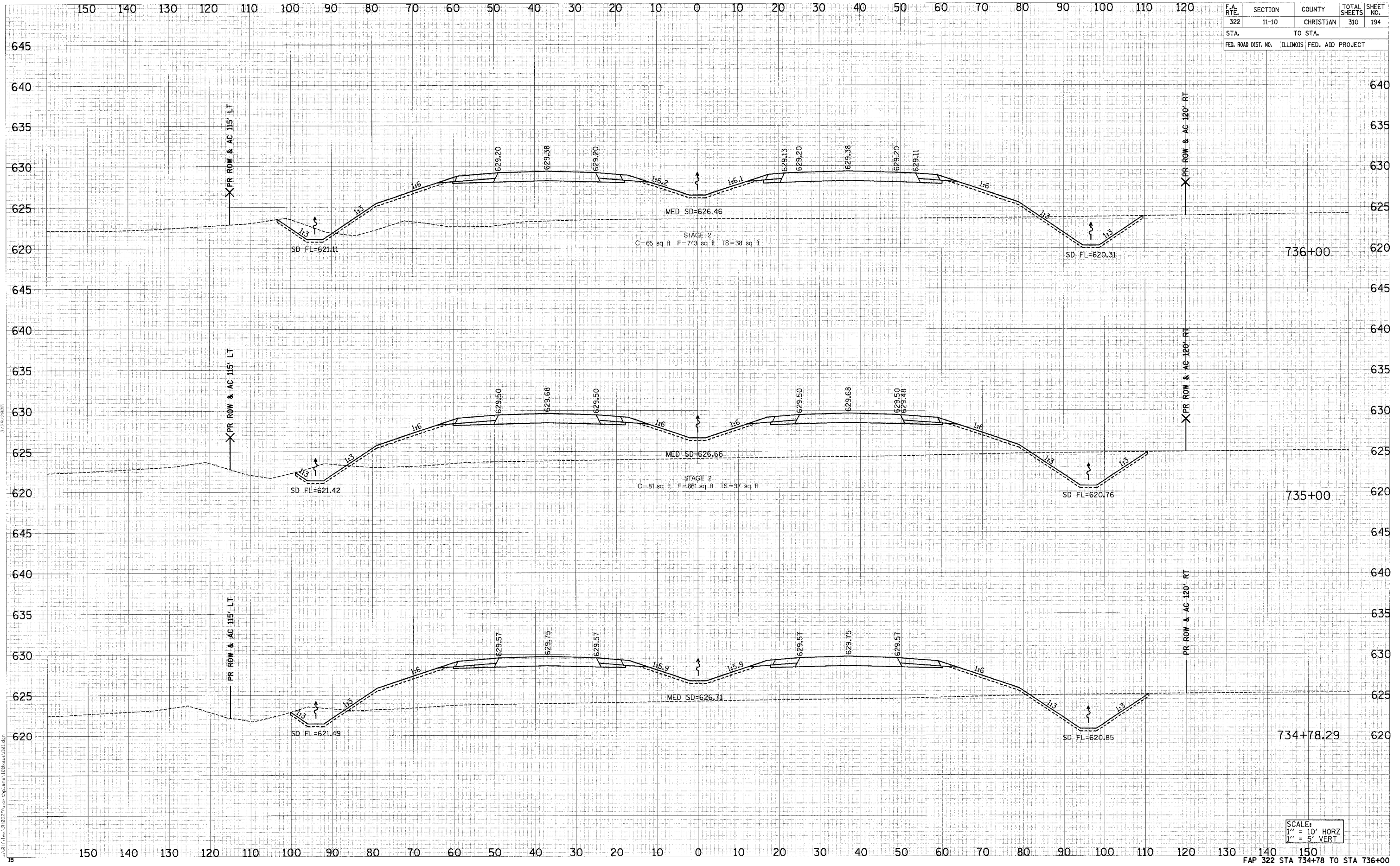

BY	DATE
REVISIONS	
NOTED	
TEMPLA	
AREAS	
CHECKED	

BY	DATE
REVISIONS	
NOTED	
TEMPLA	
AREAS	
CHECKED	

SCALE:
1" = 10' HORZ
1" = 5' VERT

F.A. RTE.	SECTION	COUNTY	TOTAL SHEETS	SHEET NO.
322	11-10	CHRISTIAN	310	196
STA.		TO STA.		
FED. ROAD DIST. NO.		ILLINOIS FED. AID PROJECT		

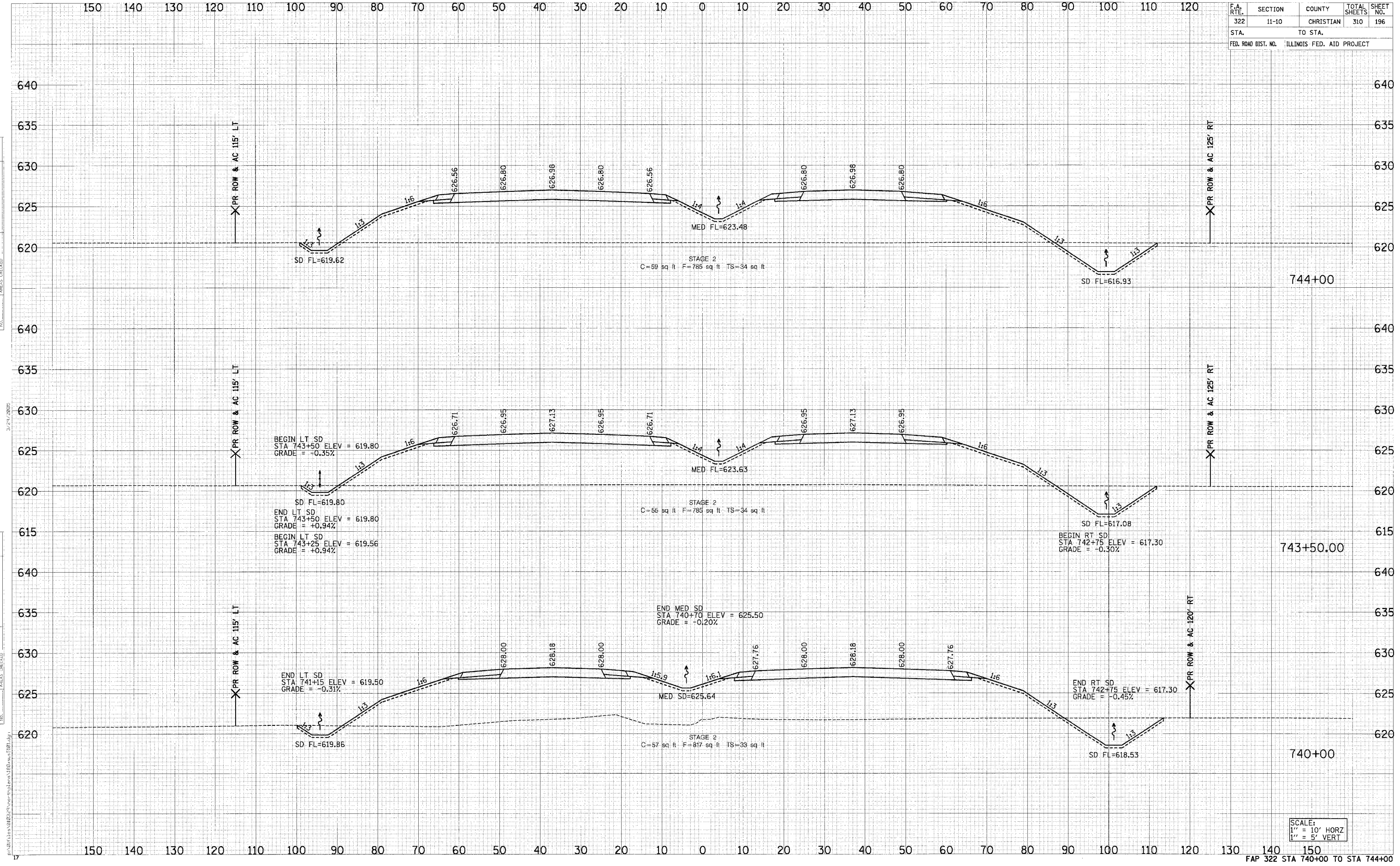

FILE	DATE
SAVED	
PRINTED	
NOTED	
AREAS CHECKED	

ORIGINAL	DATE
SAVED	
PRINTED	
NOTED	
AREAS CHECKED	

SCALE:
 1" = 10' HORZ
 1" = 5' VERT

F.A. RTE.	SECTION	COUNTY	TOTAL SHEETS	SHEET NO.
322	11-10	CHRISTIAN	310	198
STA.		TO STA.		
FED. ROAD DIST. NO.		ILLINOIS FED. AID PROJECT		

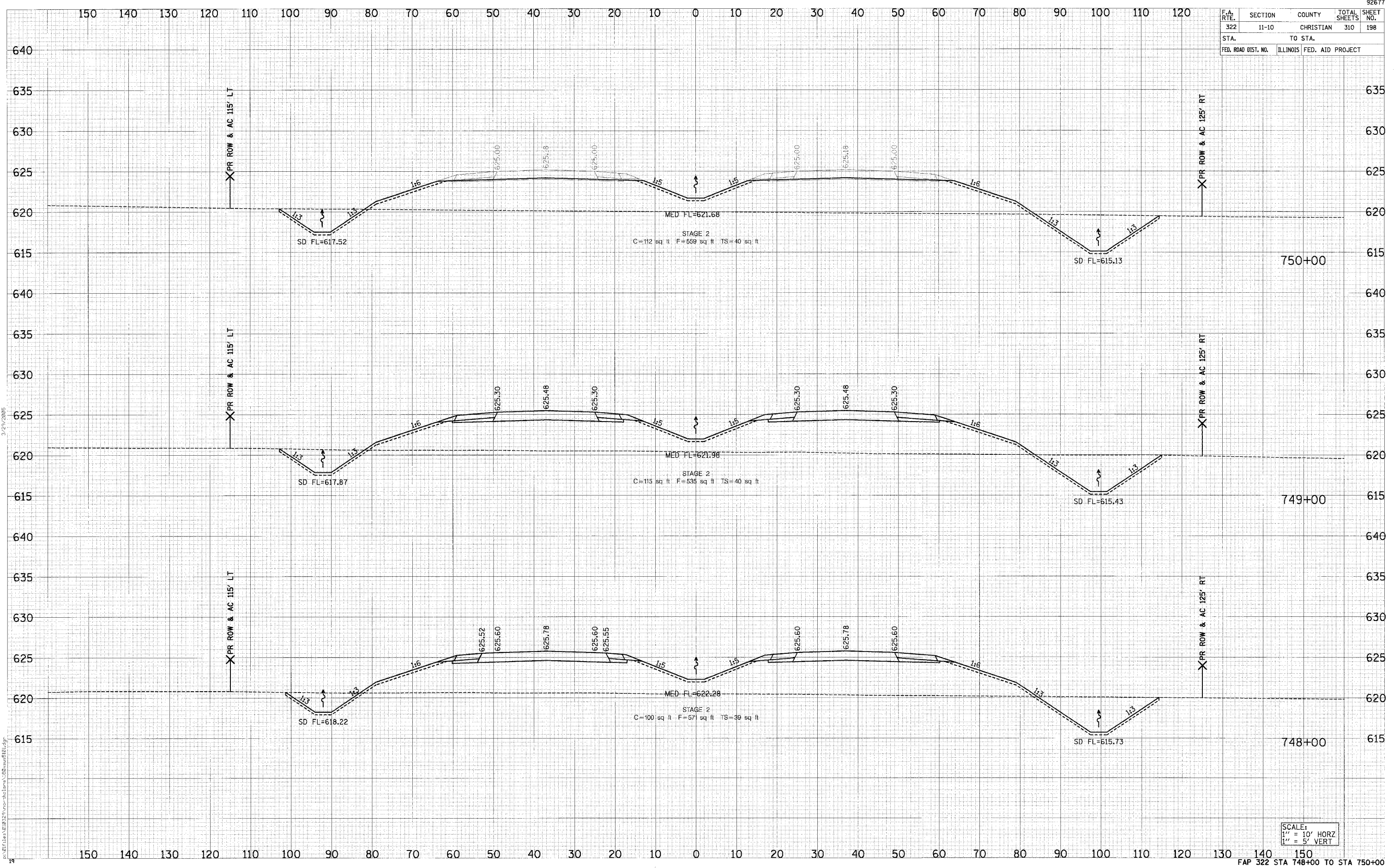

DATE _____
 BY _____
 SURVEYED _____
 DRAWN _____
 CHECKED _____
 DATE _____
 BY _____
 SURVEYED _____
 DRAWN _____
 CHECKED _____

DATE _____
 BY _____
 SURVEYED _____
 DRAWN _____
 CHECKED _____
 DATE _____
 BY _____
 SURVEYED _____
 DRAWN _____
 CHECKED _____

SCALE:
 1" = 10' HORZ
 1" = 5' VERT

F.A. RTE.	SECTION	COUNTY	TOTAL SHEET NO.
322	11-10	CHRISTIAN	310 200
STA.		TO STA.	
FED. ROAD DIST. NO.		ILLINOIS FED. AID PROJECT	

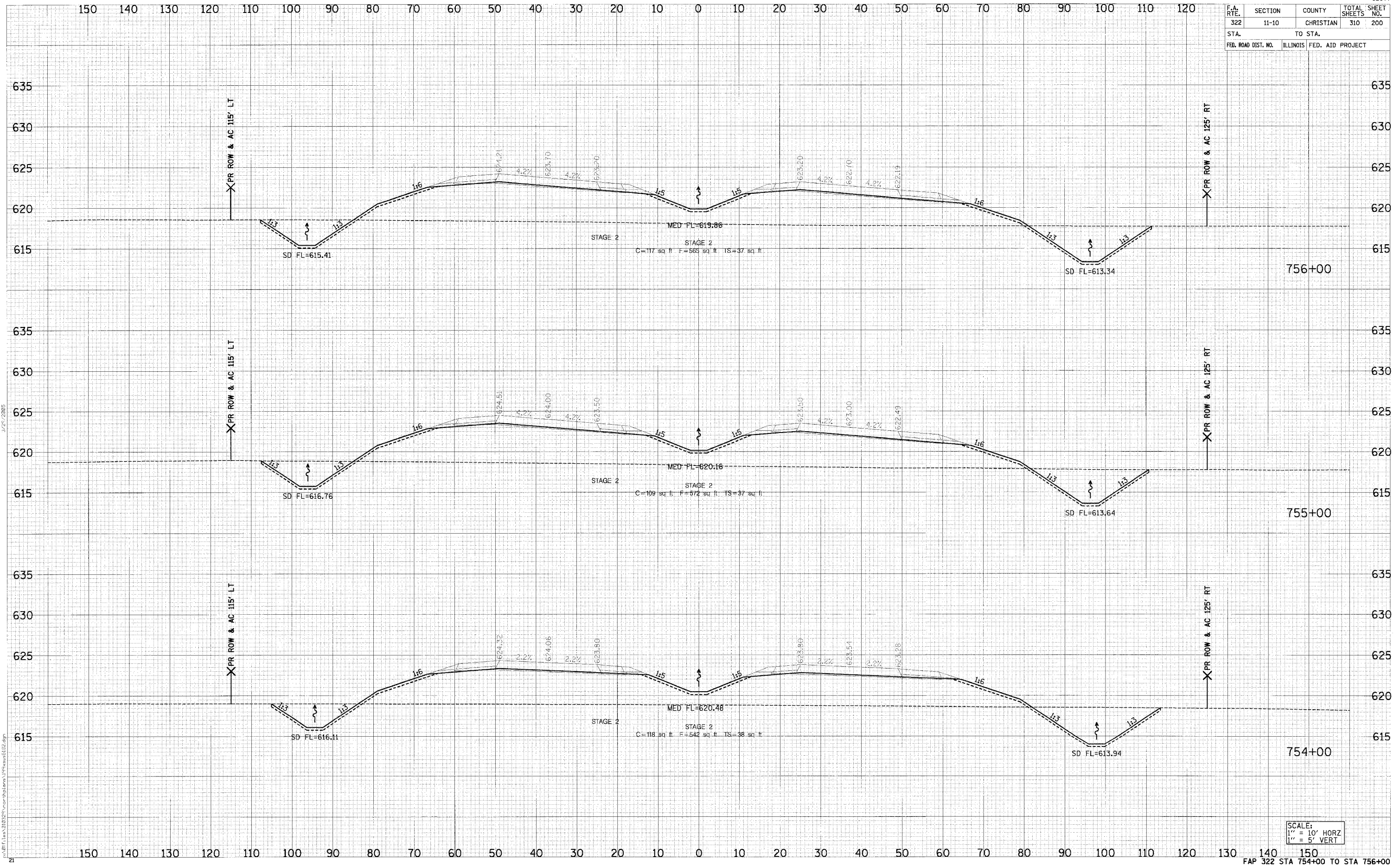

DATE	BY
DATE	BY
DATE	BY

DATE	BY
DATE	BY
DATE	BY

SCALE:
1" = 10' HORIZ
1" = 5' VERT