

FAP ROUTE	SECTION	COUNTY	TOTAL SHEETS	SHEET NO.
600	51RS-3	*	347	10
STA.		TO STA.		
CONTRACT : 76563				
* ST. CLAIR & MONROE COUNTIES				

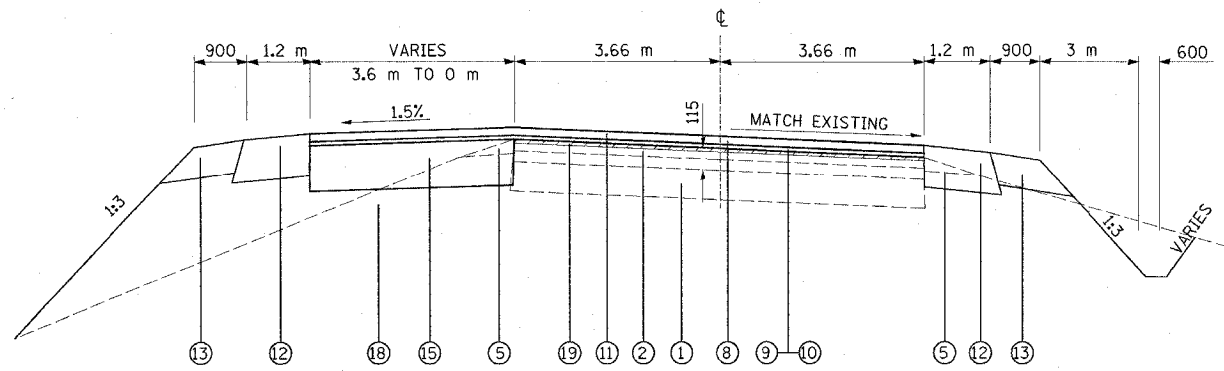

**SUPERELEVATED SECTION**  
 SE TRANSITION STA 28+618.2 TO STA 28+644.2  
 STA. 28+644.2 TO STA. 28+735.99

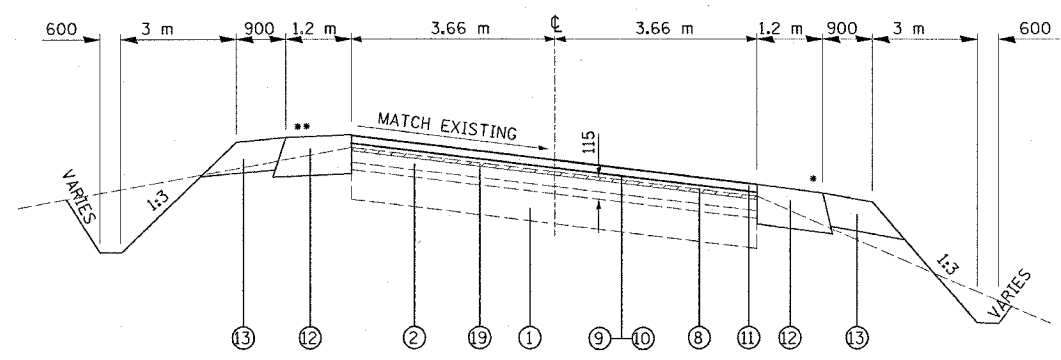

**SUPERELEVATED SECTION**  
 SE TRANSITION STA 28+582.3 TO STA 28+618.2  
 STA. 28+735.99 TO STA. 29+011.3  
 SE TRANSITION STA 29+011.2 TO STA 29+073.0

**LEGEND**

- ① EXISTING CONCRETE PAVEMENT
- ② EXISTING RESURFACING
- ③ EXISTING CONCRETE WIDENING
- ④ EXISTING BITUMINOUS SHOULDER (TBR)
- ⑤ EXISTING AGGREGATE SHOULDER
- ⑥ EXISTING CURB AND GUTTER
- ⑦ EXISTING BITUMINOUS PARKING LANE
- ⑧ LEVELING BINDER (MACHINE METHOD), SUPERPAVE N70, 19 mm
- ⑨ AGGREGATE (PRIME COAT)
- ⑩ BITUMINOUS MATERIALS (PRIME COAT)
- ⑪ BITUMINOUS CONCRETE SURFACE COURSE, SUPERPAVE, MIX D, N70, 38 mm
- ⑫ BITUMINOUS SHOULDER SUPERPAVE, 200 mm
- ⑬ AGGREGATE SHOULDER, TYPE A, 150 mm
- ⑭ STRIP REFLECTIVE CRACK CONTROL
- ⑮ BITUMINOUS BASE COURSE, SUPERPAVE, 230 mm
- ⑯ BITUMINOUS BASE COURSE, SUPERPAVE, 150 mm
- ⑰ TYPE A GUTTER
- ⑱ OMITTED
- ⑲ BITUMINOUS SURFACE REMOVAL, 20 mm

DENOTES REMOVAL

**NOTES:**

- SHOULDER SLOPE SHALL BE THE SAME AS SUPERELEVATION RATE BUT NOT LESS THAN 4%. (STD 482006)
  - WHEN THE SUPERELEVATION RATE IS BETWEEN 0% AND 4%, SHOULDER SLOPE SHALL BE 4%. MAXIMUM BREAKOVER OF 8%. (STD 482006)
- BITUMINOUS PARKING LANE VARIES IN THICKNESS FROM 50 TO 115 mm.

ALL DIMENSIONS ARE IN mm UNLESS DESIGNATED OTHERWISE

REVISIONS	
NAME	DATE

**ILLINOIS DEPARTMENT OF TRANSPORTATION**  
**TYPICAL SECTIONS**

FAP ROUTE 600  
 SECTION 51RS-3  
 ST. CLAIR & MONROE COUNTIES

DRAWN BY:

4/29/2005 8:22:00 AM  
 Friday April 29, 2005 8:22:00 AM  
 c:\projects\mtd\2851\plan\superelev.dgn LV1:EG