

FAP ROUTE	SECTION	COUNTY	TOTAL SHEETS	SHEET NO
600	5IRS-3	*	347	9
STA. _____ TO STA. _____				
CONTRACT : 76563				
* ST. CLAIR & MONROE COUNTIES				

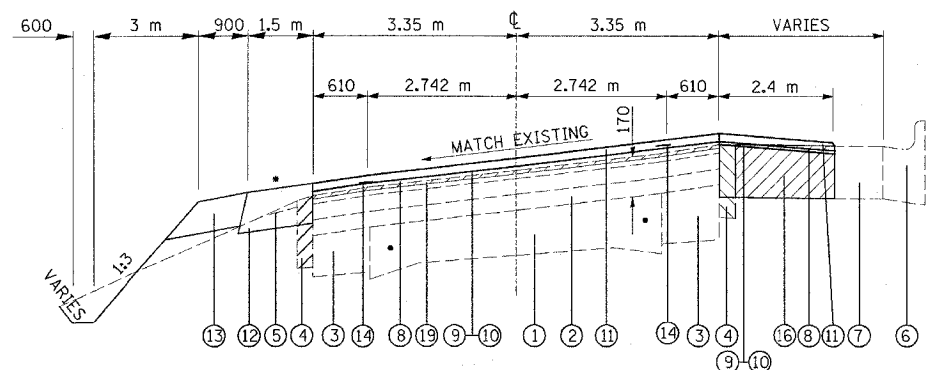

SUPERELEVATED SECTION
STA. 21+826.7 TO STA. 21+861.6

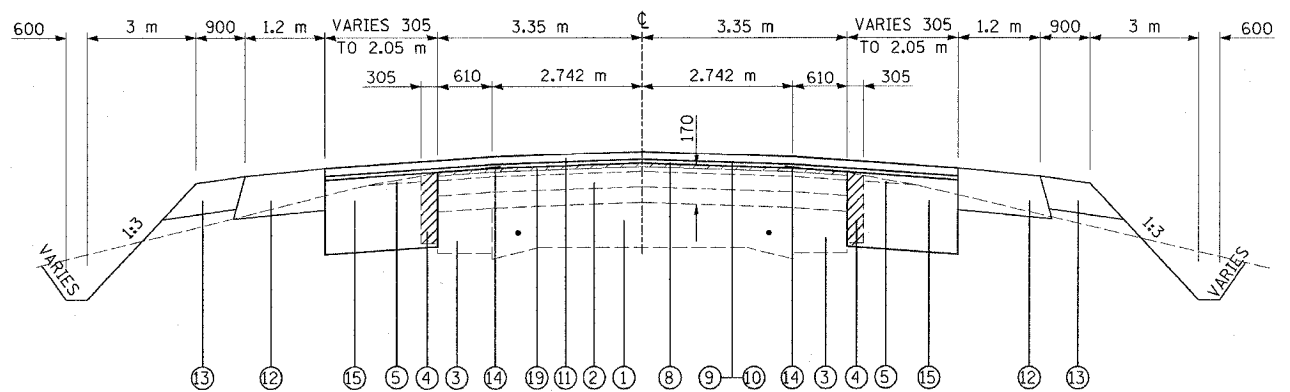

TYPICAL SECTION
STA. 23+422.4 TO STA. 23+722.1
STA. 26+574.0 TO STA. 26+881.1

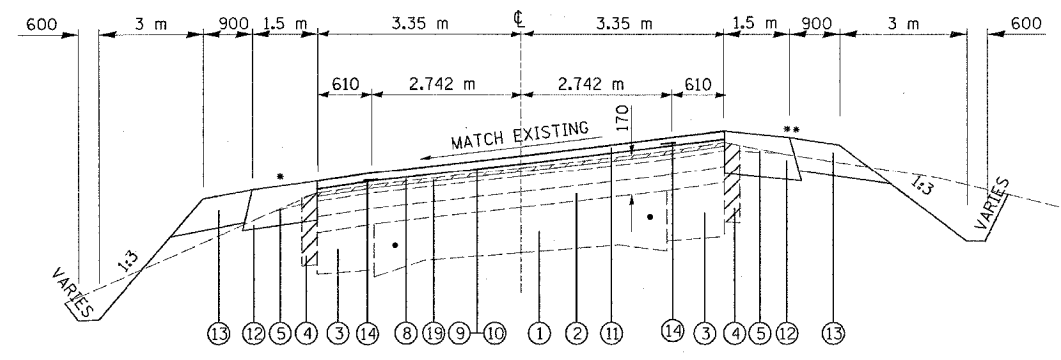

SUPERELEVATED SECTION
STA. 28+107.1 TO STA. 28+359.3
STA. 29+551.7 TO STA. 29+990.5
STA. 30+603.4 TO STA. 30+883.4
STA. 31+555.4 TO STA. 31+819.0

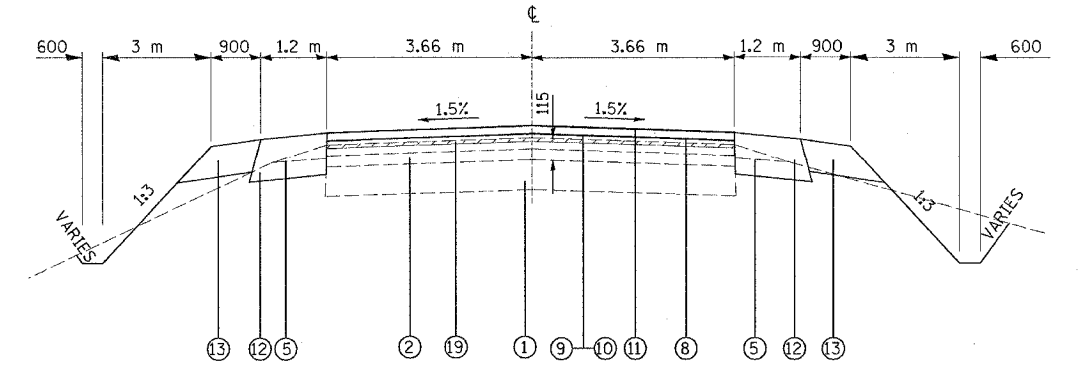

TYPICAL SECTION
STA. 28+423.2 TO STA. 28+582.3
STA. 29+073.0 TO STA. 29+227.6

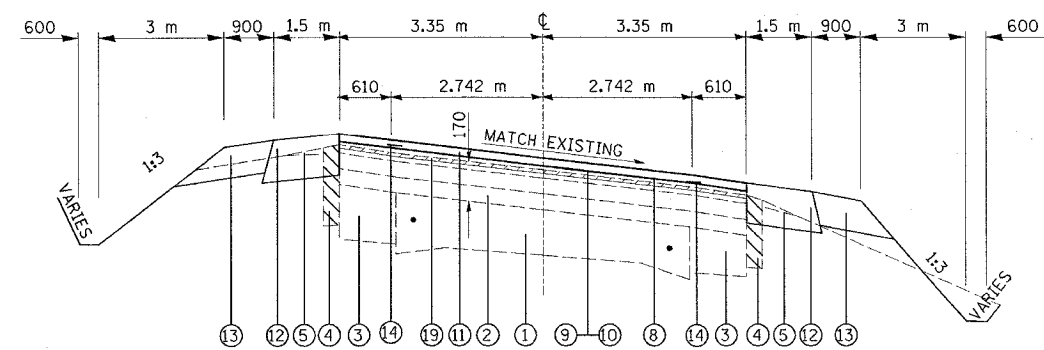

SUPERELEVATED SECTION
STA. 21+978.1 TO STA. 22+074.1
STA. 30+987.8 TO STA. 31+268.7

LEGEND

- ① EXISTING CONCRETE PAVEMENT
- ② EXISTING RESURFACING
- ③ EXISTING CONCRETE WIDENING
- ④ EXISTING BITUMINOUS SHOULDER (TBR)
- ⑤ EXISTING AGGREGATE SHOULDER
- ⑥ EXISTING CURB AND GUTTER
- ⑦ EXISTING BITUMINOUS PARKING LANE
- ⑧ LEVELING BINDER (MACHINE METHOD), SUPERPAVE N70, 19 mm
- ⑨ AGGREGATE (PRIME COAT)
- ⑩ BITUMINOUS MATERIALS (PRIME COAT)
- ⑪ BITUMINOUS CONCRETE SURFACE COURSE, SUPERPAVE, MIX D, N70, 38 mm
- ⑫ BITUMINOUS SHOULDER SUPERPAVE, 200 mm
- ⑬ AGGREGATE SHOULDER, TYPE A, 150 mm
- ⑭ STRIP REFLECTIVE CRACK CONTROL
- ⑮ BITUMINOUS BASE COURSE, SUPERPAVE, 230 mm
- ⑯ BITUMINOUS BASE COURSE, SUPERPAVE, 150 mm
- ⑰ TYPE A GUTTER
- ⑱ OMITTED
- ⑲ BITUMINOUS SURFACE REMOVAL, 20 mm

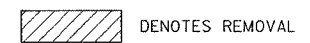

NOTES:

- SHOULDER SLOPE SHALL BE THE SAME AS SUPERELEVATION RATE BUT NOT LESS THAN 4%. (STD 482006)
 - WHEN THE SUPERELEVATION RATE IS BETWEEN 0% AND 4%, SHOULDER SLOPE SHALL BE 4%, MAXIMUM BREAKOVER OF 8%. (STD 482006)
- BITUMINOUS PARKING LANE VARIES IN THICKNESS FROM 50 TO 115 mm.

ALL DIMENSIONS ARE IN mm UNLESS DESIGNATED OTHERWISE

REVISIONS	
NAME	DATE

ILLINOIS DEPARTMENT OF TRANSPORTATION

TYPICAL SECTIONS

FAP ROUTE 600
SECTION 5IRS-3
ST. CLAIR & MONROE COUNTIES

DRAWN BY: _____

DATE	
BY	
DESIGNED	
CHECKED	
PLANNED	
NO.	

4/29/2005 8:22:00 AM
Fr:day Apr11 2005 8:22:00 AM
LVA-63