

ISLAND DETAIL STA./OFFSETS
FAP 502 (IL 57) STATIONING

- I1 69+56.19
34.00' RT
- I2 69+56.19
38.00' RT
- I3 69+60.67
40.00' RT
2.0' R.
- I4 69+68.73
51.35' RT
2.0' R.
- I5 69+68.63
55.53' RT
- I6 69+70.36
56.53' RT
- I7 69+74.67
39.00' RT
3.0' R.
- I8 69+83.30
34.00' RT

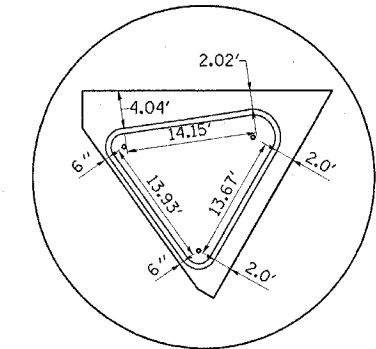

M-6.06 ISLAND DETAIL

ISLAND DETAIL (NOT TO SCALE)
STAGE IV CONSTRUCTION

MEDIAN BARRIER SEPARATOR STA./OFFSETS

PR. RADIO RD. STATIONING
STA. 48+53.82 - 49+58.00
STAGE IV CONSTRUCTION

- | | |
|-------------------------|-------------------------|
| B1 48+55.32
6.50' LT | B5 49+56.50
6.50' LT |
| B2 48+54.07
6.00' LT | B6 49+58.00
6.00' LT |
| B3 48+53.82
6.00' LT | B7 49+57.75
6.00' LT |
| B4 48+55.32
5.50' LT | B8 49+56.50
5.50' LT |

MEDIAN BARRIER SEPARATOR STA./OFFSETS

PR. RADIO RD. STATIONING
STA. 46+99.04 - 47+85.59
STAGE IV CONSTRUCTION

- | | |
|-----------------------------------|-------------------------|
| M1 46+99.29, 6.00' RT
0.25' R. | M5 47+85.59
6.01' RT |
| M2 47+00.54
5.50' RT | M6 47+85.34
6.00' RT |
| M3 47+00.54
6.50' RT | M7 47+84.09
5.50' RT |
| M4 46+99.04
6.00' RT | M8 47+84.09
6.50' RT |

REVISIONS	
NAME	DATE

ILLINOIS DEPARTMENT OF TRANSPORTATION
ISLAND DETAIL
MEDIAN BARRIER SEPARATORS

SCALE: VERT.
HORIZ.
DATE 01-26-05

DRAWN BY TMJ
CHECKED BY MEB