

F.A.S. RTE.	SECTION	COUNTY	TOTAL SHEETS	SHEET NO.
1678	6 MFT, Q	EDGAR	29	1

D-95-015-05

STATE OF ILLINOIS
DEPARTMENT OF TRANSPORTATION
DIVISION OF HIGHWAYS

**PROPOSED
HIGHWAY PLANS**

F.A.S. ROUTE 1678 (SCOTTLAND ROAD)
SECTION 6 MFT, Q
EDGAR COUNTY

SEAL COAT 2 MILES NORTH OF SCOTTLAND TO U.S. 36
C-95-016-05

FOR INDEX OF SHEETS, SEE SHEET NO. 2
FOR SUMMARY OF QUANTITIES, SEE SHEET NO. 4

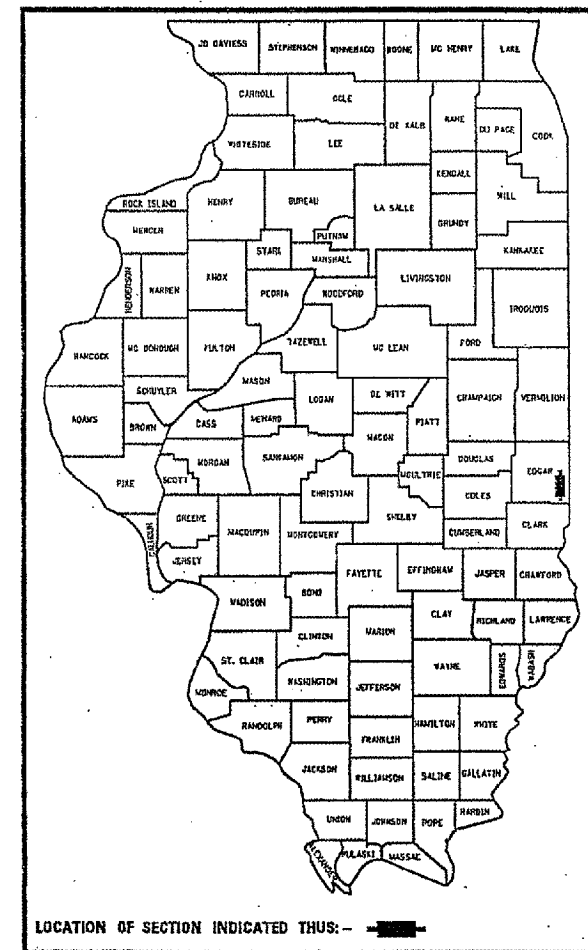

(217) 465-4181

PROJECT ENGINEER: JIM BRANDENBURG

DESIGNER: CAREN ELLEDGE

**CURRENT ADT:
F.A.S. 1678 = 350 (2003)**

**DESIGN DESIGNATION
MAJOR COLLECTOR**

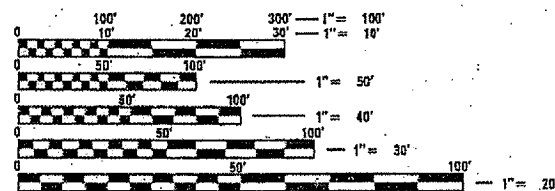

FULL SIZE PLANS HAVE BEEN PREPARED USING STANDARD ENGINEERING SCALES. REDUCED SIZED PLANS WILL NOT CONFORM TO STANDARD SCALES. IN MAKING MEASUREMENTS ON REDUCED PLANS, THE ABOVE SCALES MAY BE USED.

J.U.L.I.E.
JOINT UTILITY LOCATION INFORMATION FOR EXCAVATION
1-800-892-0123

CONTRACT NO. 70467

SECTION 6 MFT, Q
ENDS STA. 105+45

RAILROAD OMISSION
STA. 23+00 - STA. 23+40

SECTION 6 MFT, Q
BEGINSS STA. 0+09

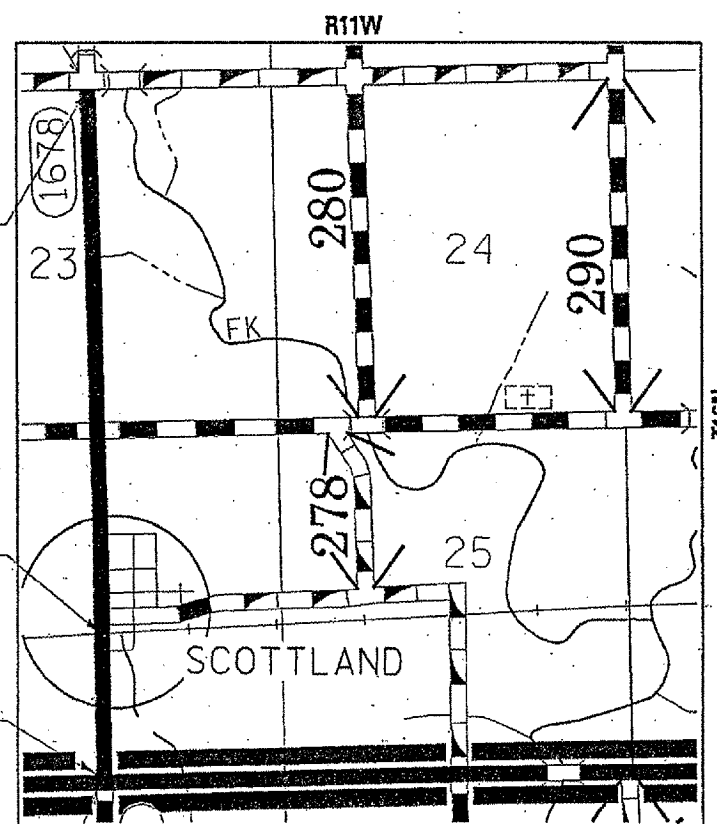

R11W
SCALE: N/A

TOTAL LENGTH OF SECTION & PROJECT = 10,536 FEET = 1.995 MILES
NET LENGTH OF SECTION & PROJECT = 10,476 FEET = 1.984 MILES

STATE OF ILLINOIS
DEPARTMENT OF TRANSPORTATION
DIVISION OF HIGHWAYS

SUBMITTED 3/24 2005
Mark S. Lowe
DEPUTY DIRECTOR OF HIGHWAYS, REGION ENGINEER

May 13 2005
Mike Rine
ENGINEER OF DESIGN AND ENVIRONMENT

May 13 2005
Vester Moore
DIRECTOR OF HIGHWAYS, CHIEF ENGINEER

**PRINTED BY THE AUTHORITY
OF THE STATE OF ILLINOIS**

F.A.S. RTE.	SECTION	COUNTY	TOTAL SHEETS	SHEET NO.
1678	6 MET. Q	EDGAR	29	2

CONTRACT NO. 70467

INDEX OF SHEETS

<u>SHEET NO.</u>	<u>ITEM</u>
1	COVER SHEET
2	INDEX OF SHEETS
2	LIST OF HIGHWAY STANDARDS
3-4	GENERAL NOTES
5	SUMMARY OF QUANTITIES
6	EXISTING TYPICAL CROSS SECTIONS
7	PROPOSED TYPICAL CROSS SECTIONS
8	SCHEDULES OF QUANTITIES
9-24	PLAN SHEETS
25-26	DETAILS
27-29	TYPICAL APPLICATIONS OF PAVEMENT MARKINGS AND MARKERS

STANDARDS

000001-04	STANDARD SYMBOLS, ABBREVIATIONS AND PATTERNS
001006	DECIMAL ON AN INCH AND OF A FOOT
701201-02	LANE CLOSURE 2L, 2W DAY ONLY ON-ROAD TO 24- OFF-ROAD FOR SPEEDS > 45 MPH
701301-02	LANE CLOSURE 2L, 2W SHORT TIME OPERATIONS
701306-01	LANE CLOSURE 2L, 2W SLOW MOVING OPERATIONS-DAY ONLY FOR SPEEDS > 45 MPH
701311-02	LANE CLOSURE 2L, 2W MOVING OPERATIONS-DAY ONLY
702001-05	TRAFFIC CONTROL DEVICES
780001-01	TYPICAL PAVEMENT MARKINGS

GENERAL NOTES

F.A.S. RTE.	SECTION	COUNTY	TOTAL SHEETS	SHEET NO.
1678	6 MFT. Q	EDGAR	29	3

CONTRACT NO. 70467

G. N. -100
ENGLISH UNITS OF MEASUREMENT SHALL GOVERN OVER AND SUPERSEDE ANY METRIC UNITS SHOWN IN THIS CONTRACT. WHERE INCLUDED, METRIC UNITS ARE FOR INFORMATION ONLY.

G. N. -107.12
THE NAME, ADDRESS AND TELEPHONE NUMBER OF THE LOCAL RAILROAD CONTACT IS:

Mr. Gale Free
Roadmaster
CSX Transportation
564 CSX Lane
Danville, IL 61834

SPECIAL ATTENTION IS CALLED TO ARTICLE 107.12 REGARDING RAILROAD FLAGGERS. THE NAME, ADDRESS AND TELEPHONE NUMBER OF THE RAILROAD CONTACT PERSON FOR FLAGGERS IS:

David Clifford
CSX Transportation
1700 West 167th Street
Calumet City, IL 60409
708-832-2170

G. N. -403
BITUMINOUS SURFACE TREATMENTS: GRADATION CA-14 (MID SPEC.) IS ASSUMED FOR COVER COATS AND GRADATION CA-16 (MID-SPEC.) IS ASSUMED FOR SEAL COATS. THE RESULTING TARGET APPLICATION RATES ARE AS FOLLOWS:

TYPE OF CONSTRUCTION	BITUMINOUS MATERIAL	APPLICATION RATE	AGGREGATE	APPLICATION RATE
PRIME COAT (AGGREGATE SURFACE)	MC-30, PEP (40300100)	0.25 GAL/SQ YD*	FA-1 OR FA-2 (40600300)	3 LBS/SQ YD
A-2 (COVER COAT)	HFP (40300300)	0.35 GAL/SQ YD	CM-16 (SPECIAL) (40300500)	20 LBS/SQ YD
A-2 (SEAL COAT)	HFP (X4032500)	0.20 GAL/SQ YD	FM-20 (SPECIAL) (40300600)	12 LBS/SQ YD

NOTE: THE ENGINEER RESERVES THE RIGHT TO ADJUST THE TARGET APPLICATION RATES AND THE QUANTITIES.

*NOTE: DO NOT PUDDLE PRIME.
SEE THIRD PARAGRAPH OF ARTICLE 403.09 FOR APPLICATION OF BITUMINOUS MATERIALS.

GENERAL NOTES

F.A.S. RTE.	SECTION	COUNTY	TOTAL SHEETS	SHEET NO.
1678	6 MFT. Q	EDGAR	29	4

CONTRACT NO. 70467

G. N. -703A

SHORT TERM PAVEMENT MARKING SHALL BE APPLIED TO THE PAVEMENT AFTER ANY OF THE FOLLOWING: COLD MILLING AND/OR PLACING BITUMINOUS MATERIALS (PRIME COAT), LEVELING BINDER (MACHINE METHOD), BINDER AND SURFACE COURSES. SHORT TERM PAVEMENT MARKING PLACED ON THE SURFACE, SHALL COINCIDE WITH THE FINAL PAVEMENT STRIPING. SHORT TERM PAVEMENT MARKING PLACED PRIOR TO THE SURFACE SHALL COINCIDE WITH THE EXISTING PAVEMENT MARKINGS. USE 4 FEET PER 40 FEET (OR 10% PER STATION).

SUMMARY OF QUANTITIES

F.A.S. RTE.	SECTION	COUNTY	TOTAL SHEETS	SHEET NO.
1678	6 MFT, Q	EDGAR	29	5

CONTRACT NO. 70467

LOCATION OF WORK:

SCOTTLAND ROAD
STA. 0+09.00
TO
STA. 105+45.00
100% STATE

CONSTRUCTION TYPE CODE:

F000
TOTAL

<u>CODE NO</u>	<u>ITEM</u>	<u>UNIT</u>	<u>QUANTITY</u>
35800100	PREPARATION OF BASE	SQ YD	3,128.0
35800200	AGGREGATE BASE REPAIR	TON	313.0
40300100	BITUMINOUS MATERIALS (PRIME COAT)	GALLON	6,451.0
40300300	BITUMINOUS MATERIALS (COVER AND SEAL COATS)	GALLON	8,214.0
40300500	COVER COAT AGGREGATE	TON	235.0
40300600	SEAL COAT AGGREGATE	TON	141.0
40600300	AGGREGATE (PRIME COAT)	TON	39.0
67100100	MOBILIZATION	L SUM	1.0
70101835	TRAFFIC CONTROL AND PROTECTION, STANDARD BLR 22	L SUM	1.0
70300100	SHORT-TERM PAVEMENT MARKING	FOOT	1,051.0
70301000	WORK ZONE PAVEMENT MARKING REMOVAL	SQ FT	350.0
* 78001110	PAINT PAVEMENT MARKING - LINE 4"	FOOT	3,274.0
X4032500	BITUMINOUS MATERIALS (COVER AND SEAL COATS), SPECIAL	GALLON	4,694.0
XX000125	AGGREGATE BASE COURSE, TYPE B, SPECIAL	TON	4,066.0
Z0048665	RAILROAD PROTECTIVE LIABILITY INSURANCE	L SUM	1.0

* SPECIALTY ITEM

EXISTING TYPICAL CROSS SECTION

STATION 0+09 TO STATION 79+05

F.A.S. RTE.	SECTION	COUNTY	TOTAL SHEETS	SHEET NO.
1678	6 MFT. Q	EDGAR	29	6

CONTRACT NO. 70467

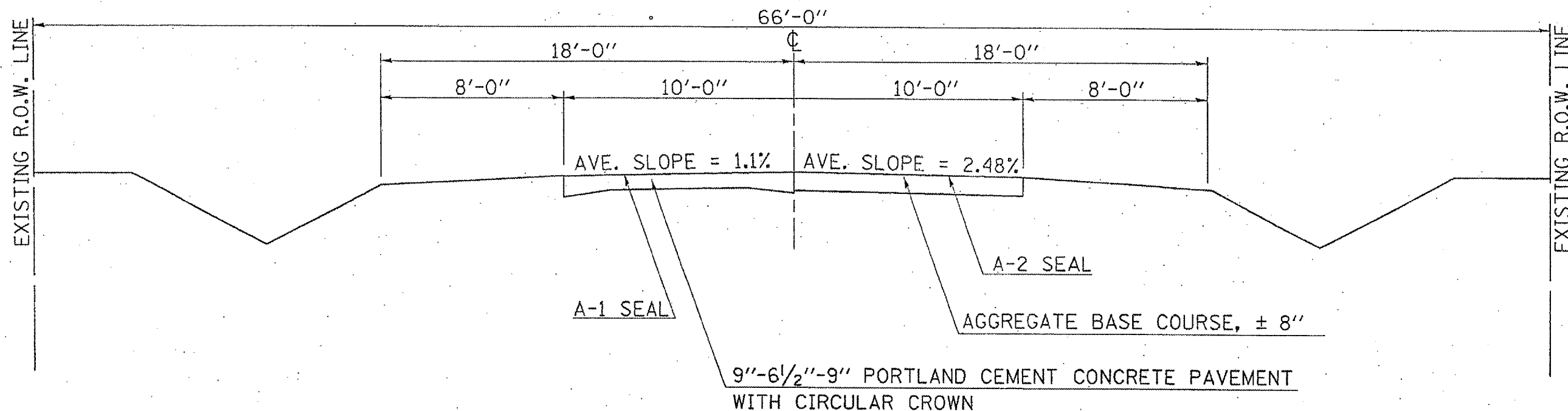

EXISTING TYPICAL CROSS SECTION

STATION 79+05 TO STATION 105+45

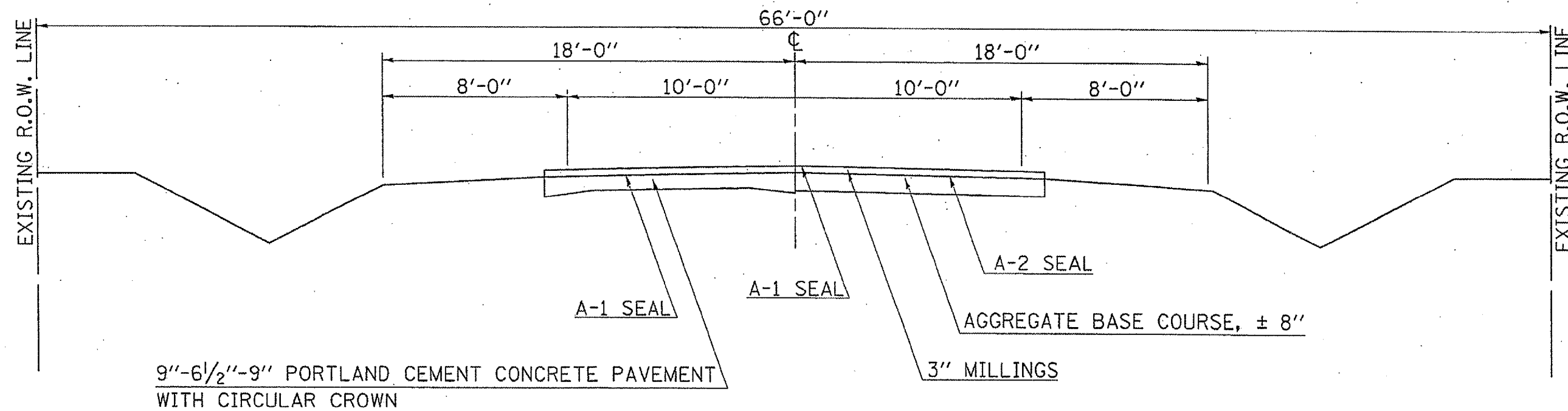

PROPOSED TYPICAL CROSS SECTION ①

STATION 0+09 TO STATION 79+05 ②

F.A.S. RTE.	SECTION	COUNTY	TOTAL SHEETS	SHEET NO.
1678	6 MFT, Q	EDGAR	29	7

CONTRACT NO. 70467

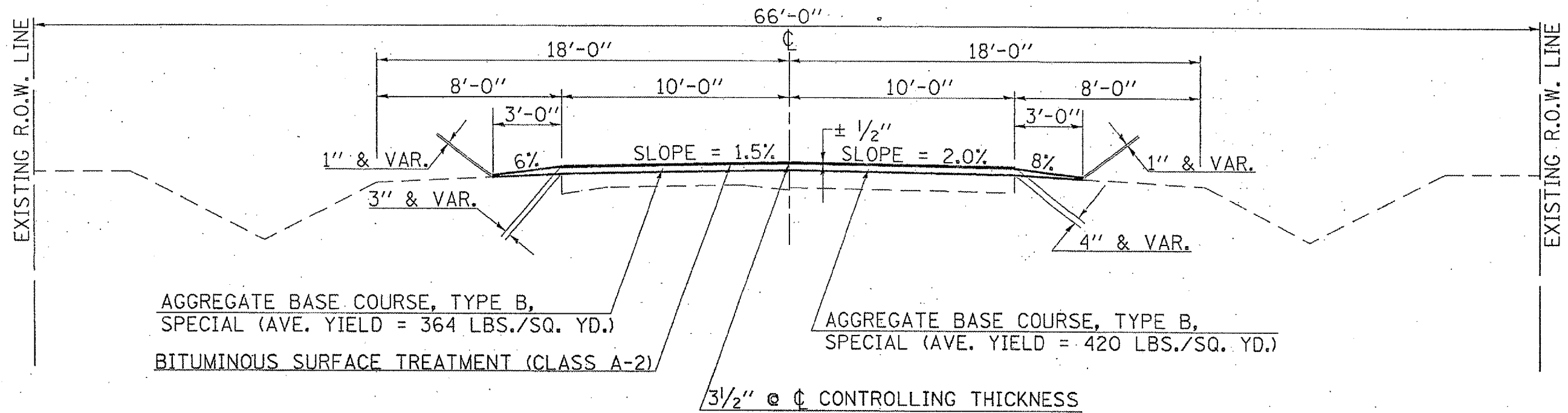

PROPOSED TYPICAL CROSS SECTION ②

① STATION 79+05 TO STATION 105+45

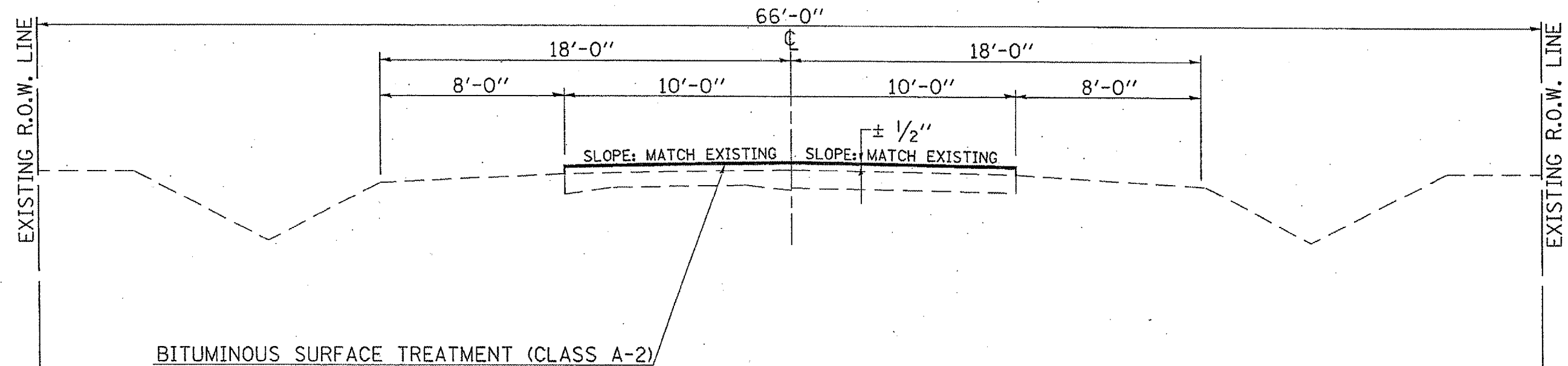

F.A.S. RTE.	SECTION	COUNTY	TOTAL SHEETS	SHEET NO.
1678	6 MFT. Q	EDGAR	29	8

CONTRACT NO. 70467

SCHEDULE OF QUANTITIES

78001180 - PAINT PAVEMENT MARKING - LINE 4"

*NO EDGE LINES

YELLOW:

SKIP-DASH LINES = 2,632 FEET

SOLID LINES = 640 FEET

NO PASSING ZONES

NB STA. 19+95 TO STA. 23+15

SB STA. 23+25 TO STA. 26+45

TOTAL QUANTITY = 3,272 FEET

XX000125 - AGGREGATE BASE COURSE TYPE B SPECIAL

SIDEROADS:

STA. 18+50.0 RT. (2240N) = 9.18 TONS
 STA. 24+15.0 RT. (2256N) = 9.18 TONS
 STA. 31+67.0 RT. (2263N) = 9.18 TONS
 STA. 37+47.0 RT. (2275N) = 9.18 TONS
 STA. 52+49.8 RT. (2308N) = 9.18 TONS
 STA. 52+49.8 LT. (2308N) = 9.18 TONS

TOTAL = 55.10 TONSPRIVATE ENTRANCES:

STA. 6+52 LT. = 0.06 TON
 STA. 7+50 RT. = 0.06 TON
 STA. 15+96 RT. = 0.06 TON
 STA. 19+52 RT. = 0.06 TON
 STA. 25+85 LT. = 0.06 TON
 STA. 25+99 RT. = 0.06 TON
 STA. 30+92 RT. = 0.06 TON
 STA. 33+44 RT. = 0.06 TON
 STA. 35+74 RT. = 0.06 TON
 STA. 39+11 RT. = 0.06 TON
 STA. 39+55 LT. = 0.06 TON
 STA. 72+79 RT. = 0.06 TON

TOTAL = 0.70 TONSMAILBOX TURNOUTS:

STA. 11+31 LT. = 0.06 TON
 STA. 16+35 LT. = 0.06 TON
 STA. 18+80 LT. = 0.06 TON
 STA. 25+85 LT. = 0.06 TON
 STA. 31+66 LT. = 0.06 TON
 STA. 36+07 LT. = 0.06 TON
 STA. 72+79 RT. = 0.06 TON

TOTAL = 0.40 TONSGRAND TOTALS = 57.00 TONS

F.A.S. RTE.	SECTION	COUNTY	TOTAL SHEETS	SHEET NO.
1678	6 MFT, Q	EDGAR	29	9

CONTRACT NO. 70467

1"=50'

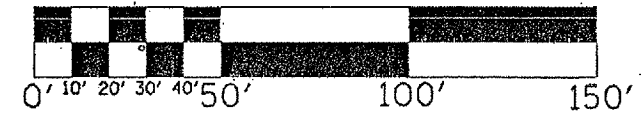

U.S. ROUTE 36

U.S. ROUTE 36

BITUMINOUS SURFACE TREATMENT (CLASS A-2)
 ONLY ON P.C.C. SIDEROAD RETURN



F.E. STA. 1+78 LT.

F.E. STA. 6+06 LT.

P.E. STA. 6+52 LT.

SEE PRIVATE ENTRANCE DETAIL

0+59

1+04

5+00

3/4" TO 3" AGGREGATE BASE COURSE,
 TYPE B SPECIAL (SEE RUNDOWN DETAIL)

SECTION 6 MFT, Q
 BEGINS STATION 0+09

PLAN NOTE:
 AGGREGATE BASE COURSE TYPE B, SPECIAL
 APRONS SHALL BE PLACED ON PRIVATE
 ENTRANCES AND MAILBOX TURNOUTS ONLY.
 APRONS BEYOND THE 3'-0" SHOULDER, AS SHOWN
 ON THE PROPOSED TYPICALS, ARE NOT REQUIRED
 AT FIELD ENTRANCES.

35800100 - PREPARATION OF BASE
STA. 9+00 - STA. 10+00 = 111.11 SQ. YD.

35800200 - AGGREGATE BASE REPAIR
STA. 9+00 - STA. 10+00 = 11.1 TONS

F.A.S. RTE.	SECTION	COUNTY	TOTAL SHEETS	SHEET NO.
1678	6 MFT. G	EDGAR	29	10

CONTRACT NO. 70467

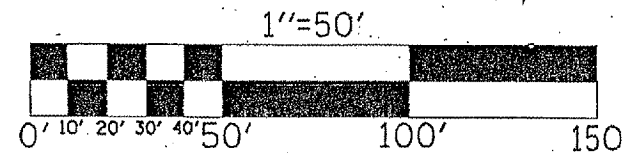

CL F.E. STA. 10+39 LT.

CL MAILBOX TURNOUT STA. 11+31 LT.
SEE MAILBOX TURNOUT DETAIL

10+00

CL P.E. STA. 7+50 RT.
SEE PRIVATE ENTRANCE DETAIL

 AGGREGATE BASE REPAIR

F.A.S. RTE.	SECTION	COUNTY	TOTAL SHEETS	SHEET NO.
1678	6 MFT. 0	EDGAR	29	11

CONTRACT NO. 70467

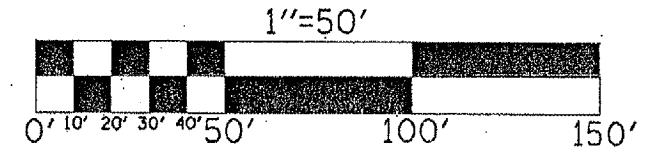

☐ MAILBOX TURNOUT STA. 16+35 LT.
SEE MAILBOX TURNOUT DETAIL

☐ MAILBOX TURNOUT STA. 18+80 LT.
SEE MAILBOX TURNOUT DETAIL

15+00

20+00

☐ P.E. STA. 15+96 RT.
SEE PRIVATE ENTRANCE DETAIL

STA. 18+50 RT.
2240 N

☐ P.E. STA. 19+52 RT.
SEE PRIVATE ENTRANCE DETAIL

35800100 - PREPARATION OF BASE
 STA. 21+40 - STA. 22+90 = 166.67 SQ. YD.

35800200 - AGGREGATE BASE REPAIR
 STA. 21+40 - STA. 22+90 = 16.7 TONS

F.A.S. RTE.	SECTION	COUNTY	TOTAL SHEETS	SHEET NO.
1678	6. MFT. Q	EDGAR	29	12

CONTRACT NO. 70467

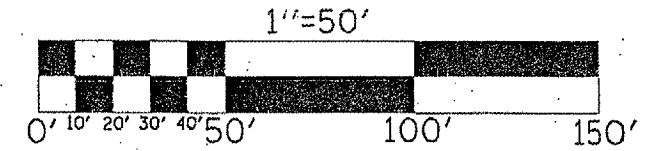

RAILROAD OMISSION
 STA. 23+00 - STA. 23+40

END BITUMINOUS SURFACE TREATMENT (CLASS. A-2)

3/4" TO 3" AGGREGATE BASE COURSE,
 TYPE B, SPECIAL (SEE RUNDOWN DETAIL)

☐ P.E. STA. 25+85 LT. &
 MAILBOX TURNOUT ON
 NORTH SIDE OF P.E.
 SEE PRIVATE ENTRANCE
 & MAILBOX TURNOUT DETAILS

☐ F.E. STA. 28+50 LT.

22+45

22+90

23+00

23+40

23+50

23+95

25+00

3" TO 3/4" AGGREGATE BASE COURSE,
 TYPE B SPECIAL (SEE RUNDOWN DETAIL)

--- STA. 24+15 RT.
 --- 2256 N ---

☐ P.E. STA. 25+99 RT.
 SEE PRIVATE ENTRANCE DETAIL

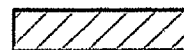
 AGGREGATE BASE REPAIR

F.A.S. RTE.	SECTION	COUNTY	TOTAL SHEETS	SHEET NO.
1678	6 MFT. Q	EDGAR	29	13

CONTRACT NO. 70467

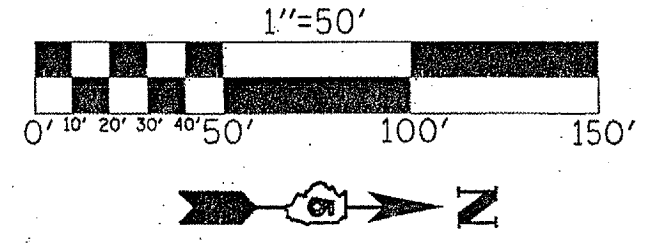

Φ F.E. STA. 28+50 LT.

Φ MAILBOX TURNOUT STA. 31+66 LT.
SEE MAILBOX TURNOUT DETAIL

30+00

35+00

Φ P.E. STA. 30+92 RT.
SEE PRIVATE ENTRANCE DETAIL

STA. 31+67 RT.
2263 N

Φ P.E. STA. 33+44 RT.
SEE PRIVATE ENTRANCE DETAIL

F.A.S. RTE.	SECTION	COUNTY	TOTAL SHEETS	SHEET NO.
1678	6 MFT. 0	EDGAR	29	14

CONTRACT NO. 70467

35800100 - PREPARATION OF BASE
 STA. 36+00 - STA. 37+00 = 111.11 SQ. YD.
 STA. 37+75 - STA. 41+00 = 361.11 SQ. YD.

35800200 - AGGREGATE BASE REPAIR
 STA. 36+00 - STA. 37+00 = 11.1 TONS
 STA. 37+75 - STA. 41+00 = 36.1 TONS

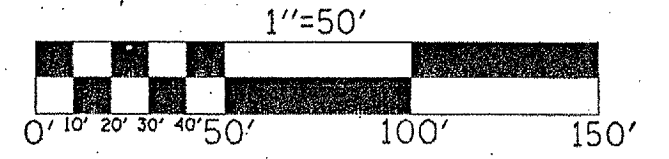

☉ MAILBOX TURNOUT STA. 36+07 LT.
 SEE MAILBOX TURNOUT DETAIL

☉ F.E. STA. 39+55 LT.

35+00

40+00

☉ P.E. STA. 35+74 RT.
 SEE PRIVATE ENTRANCE DETAIL

--- STA. 37+47 RT.
 --- 2275 N

☉ P.E. STA. 39+11 RT.
 SEE PRIVATE ENTRANCE DETAIL

 AGGREGATE BASE REPAIR

35800100 - PREPARATION OF BASE
STA. 45+60 - STA. 48+40 = 311.11 SQ. YD.

35800200 - AGGREGATE BASE REPAIR
STA. 45+60 - STA. 48+40 = 31.1 TONS

F.A.S. RTE.	SECTION	COUNTY	TOTAL SHEETS	SHEET NO.
1678	6 MFT. 0	EDGAR	29	15

CONTRACT NO. 70467

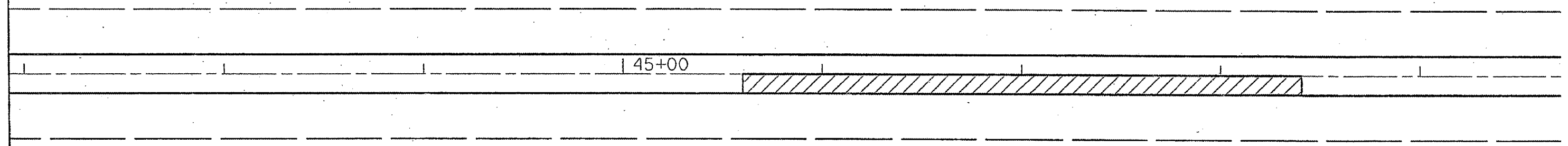
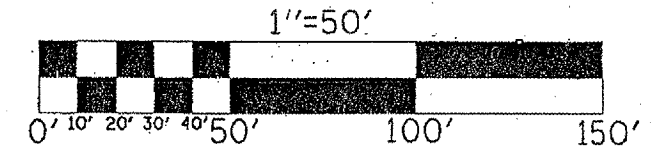

 AGGREGATE BASE REPAIR

35800100 - PREPARATION OF BASE

STA. 50+40 - STA. 52+00 = 177.78 SQ. YD.
STA. 54+50 - STA. 60+50 = 666.67 SQ. YD.

35800200 - AGGREGATE BASE REPAIR

STA. 50+40 - STA. 52+00 = 17.8 TONS
STA. 54+50 - STA. 60+50 = 66.7 TONS

F.A.S. RTE.	SECTION	COUNTY	TOTAL SHEETS	SHEET NO.
1678	6 MFT. Q	EDGAR	29	16

CONTRACT NO. 70467

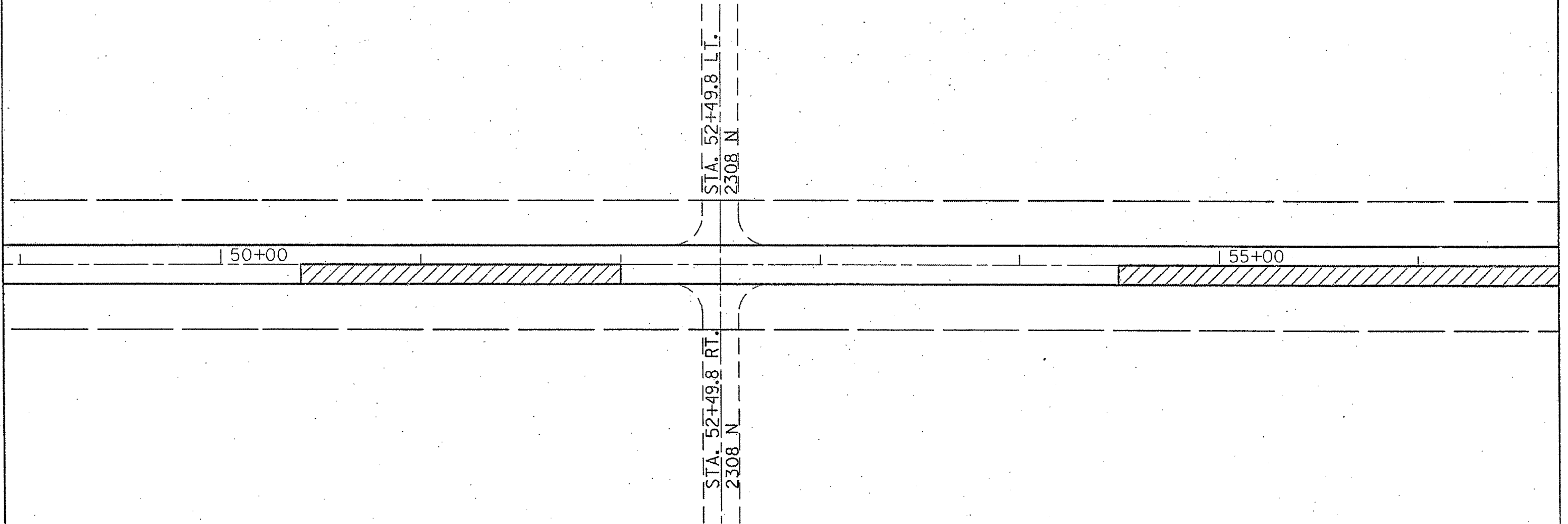
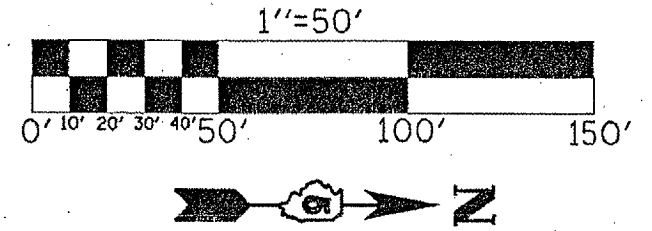

 AGGREGATE BASE REPAIR

35800100 - PREPARATION OF BASE
STA. 54+50 - STA. 60+50 = 666.67 SQ. YD.

35800200 - AGGREGATE BASE REPAIR
STA. 54+50 - STA. 60+50 = 66.7 TONS

F.A.S. RTE.	SECTION	COUNTY	TOTAL SHEETS	SHEET NO.
1678	6 MFT. Q	EDGAR	29	17

CONTRACT NO. 70467

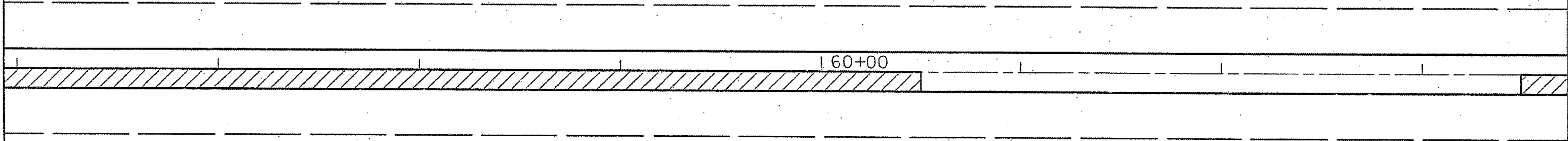
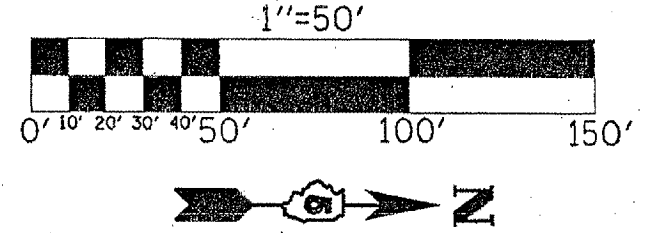

 AGGREGATE BASE REPAIR

35800100 - PREPARATION OF BASE
STA. 63+50 - STA. 74+50 = 1,222.22 SQ. YD.

35800200 - AGGREGATE BASE REPAIR
STA. 63+50 - STA. 74+50 = 122.2 TONS

F.A.S. RTE.	SECTION	COUNTY	TOTAL SHEETS	SHEET NO.
1678	6 MFT. Q	EDGAR	29	18

CONTRACT NO. 70467

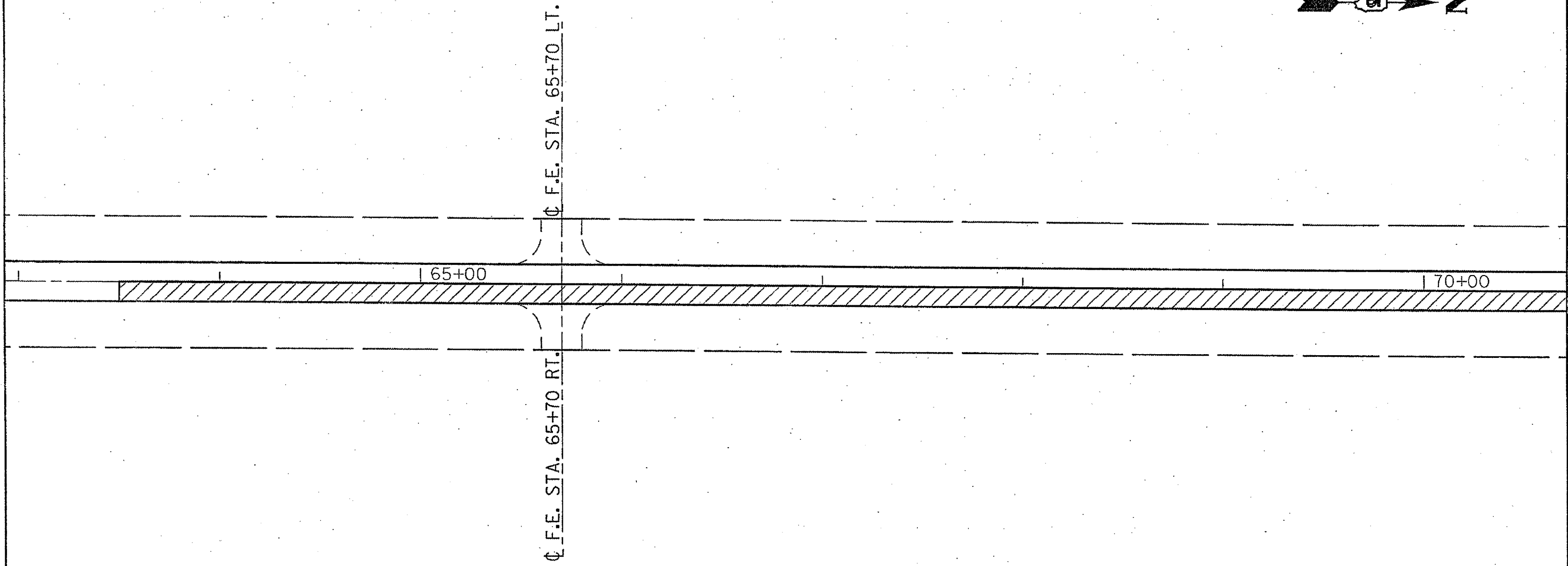
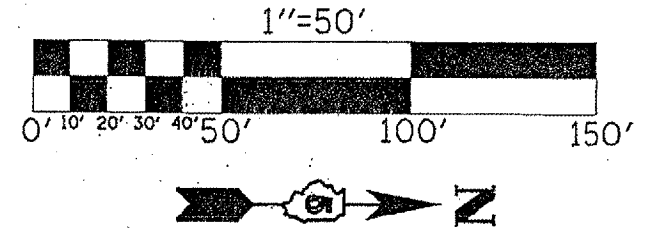

 AGGREGATE BASE REPAIR

35800100 - PREPARATION OF BASE
STA. 63+50 - STA. 74+50 = 1,222.22 SQ. YD.

35800200 - AGGREGATE BASE REPAIR
STA. 63+50 - STA. 74+50 = 122.2 TONS

F.A.S. RTE.	SECTION	COUNTY	TOTAL SHEETS	SHEET NO.
1678	6 MFT, Q	EDGAR	29	19

CONTRACT NO. 70467

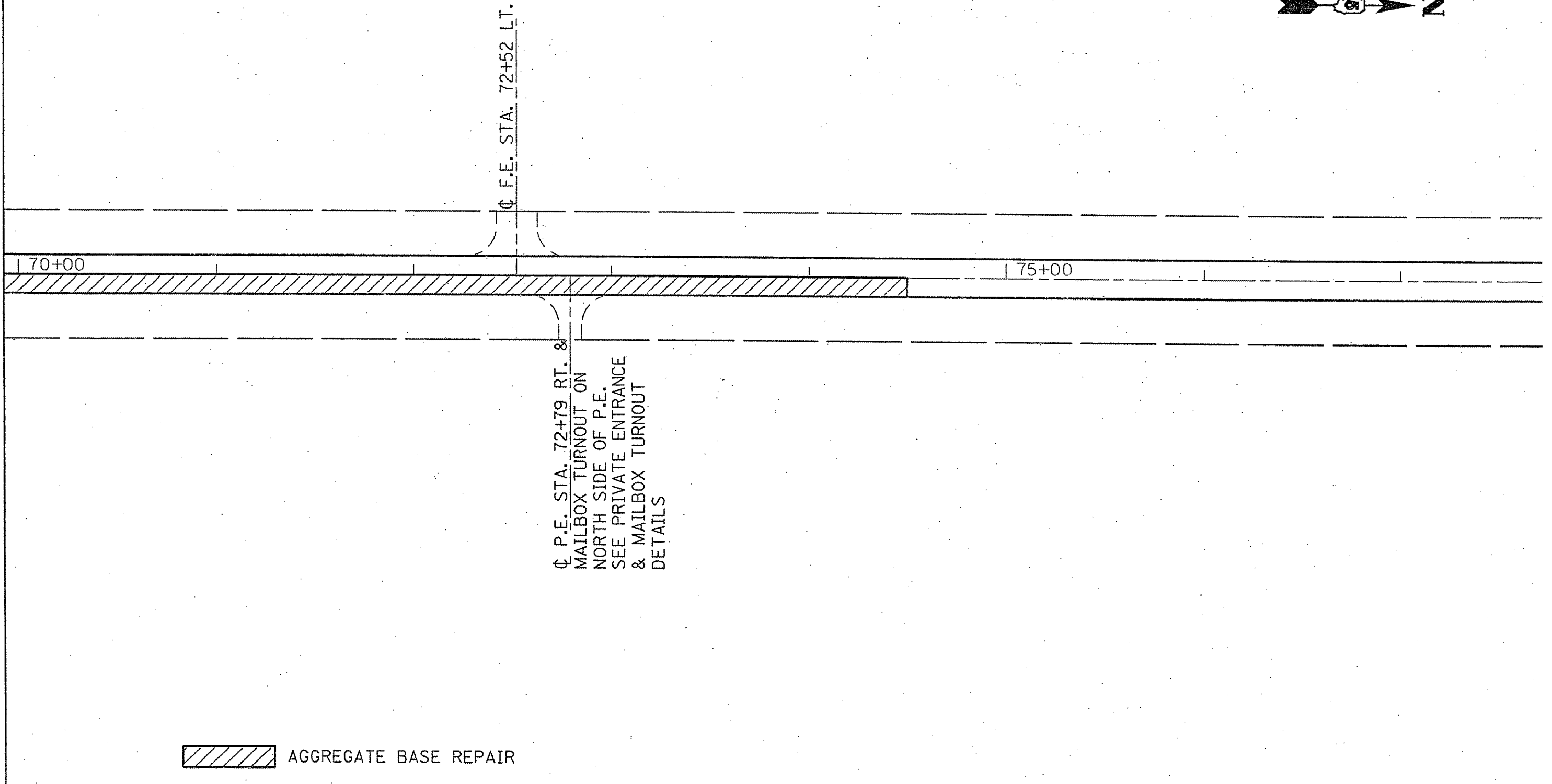
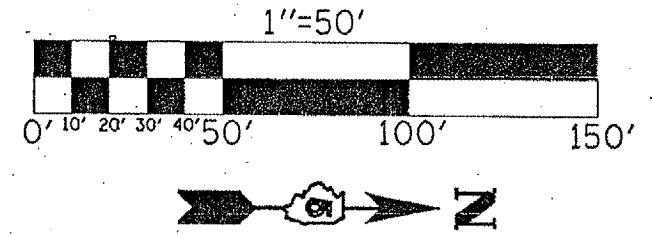

 AGGREGATE BASE REPAIR

F.A.S. RTE.	SECTION	COUNTY	TOTAL SHEETS	SHEET NO.
1678	6 MFT, Q	EDGAR	29	20

CONTRACT NO. 70467

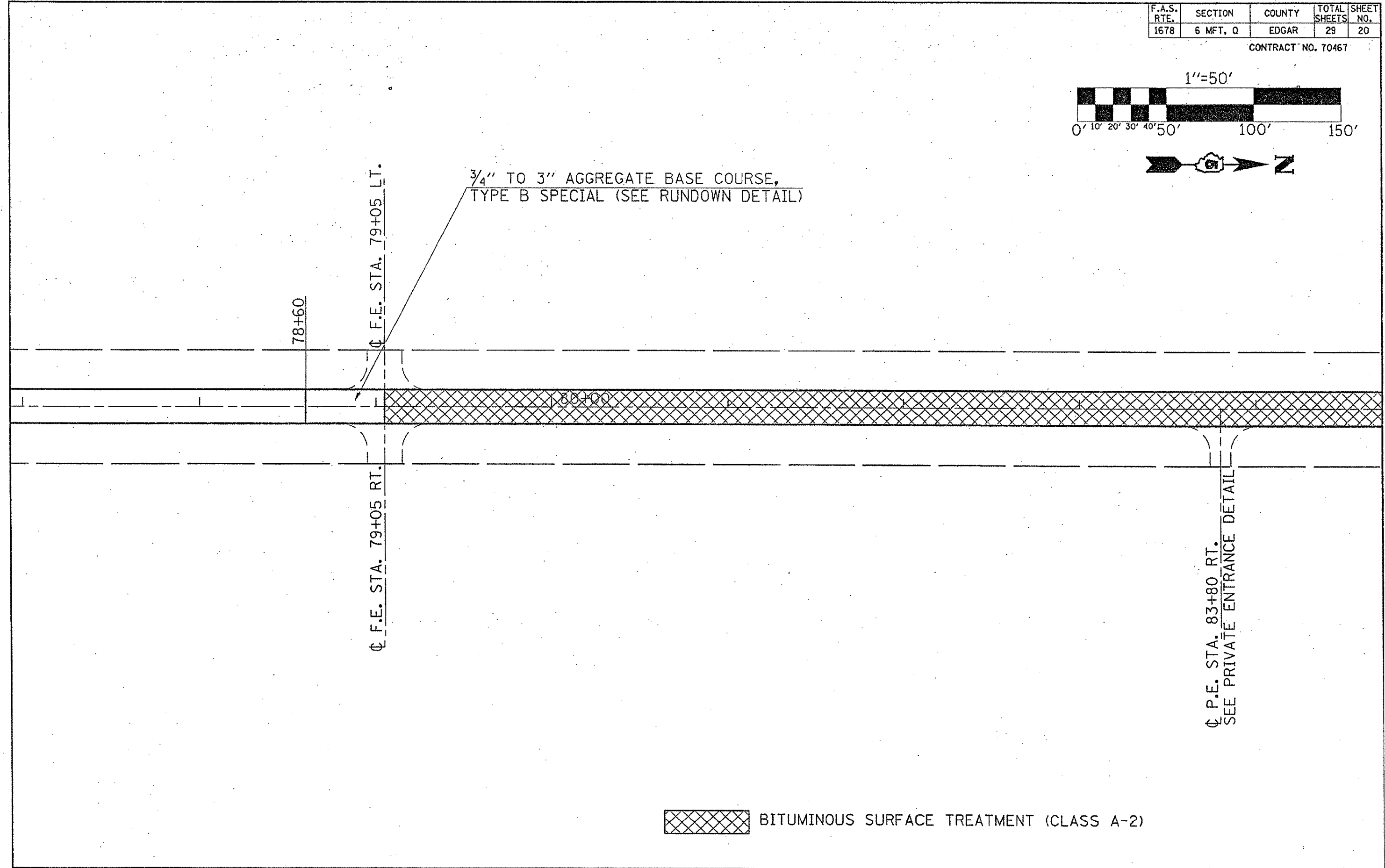
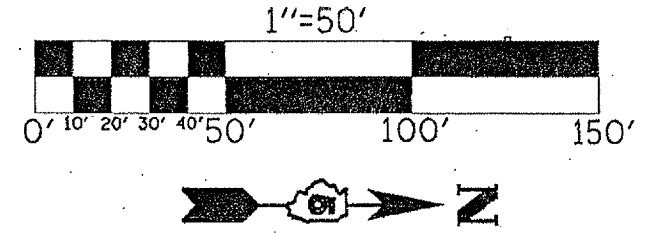

 BITUMINOUS SURFACE TREATMENT (CLASS A-2)

F.A.S. RTE.	SECTION	COUNTY	TOTAL SHEETS	SHEET NO.
1678	6 MFT, Q	EDGAR	29	21

CONTRACT NO. 70467

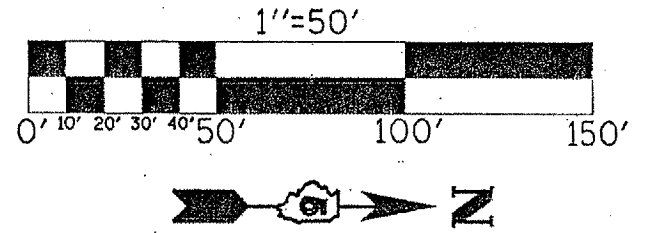

⊥ P.E. STA. 85+31 RT. &
MAILBOX TURNOUT ON
NORTH SIDE OF P.E.
SEE PRIVATE ENTRANCE
& MAILBOX TURNOUT
DETAILS

 BITUMINOUS SURFACE TREATMENT (CLASS A-2)

F.A.S. RTE.	SECTION	COUNTY	TOTAL SHEETS	SHEET NO.
1678	6 MFT, Q	EDGAR	29	22

CONTRACT NO. 70467

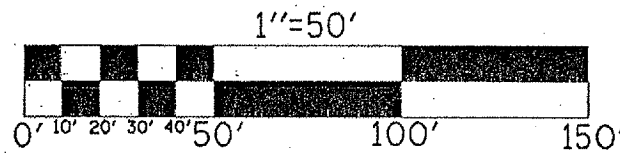

Q F.E. STA. 92+45 LT.

Q F.E. STA. 92+65 RT.

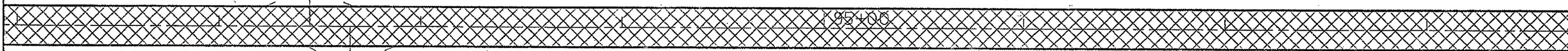

 BITUMINOUS SURFACE TREATMENT (CLASS A-2)

F.A.S. RTE.	SECTION	COUNTY	TOTAL SHEETS	SHEET NO.
1678	6 MFT, Q	EDGAR	29	23

CONTRACT NO. 70467

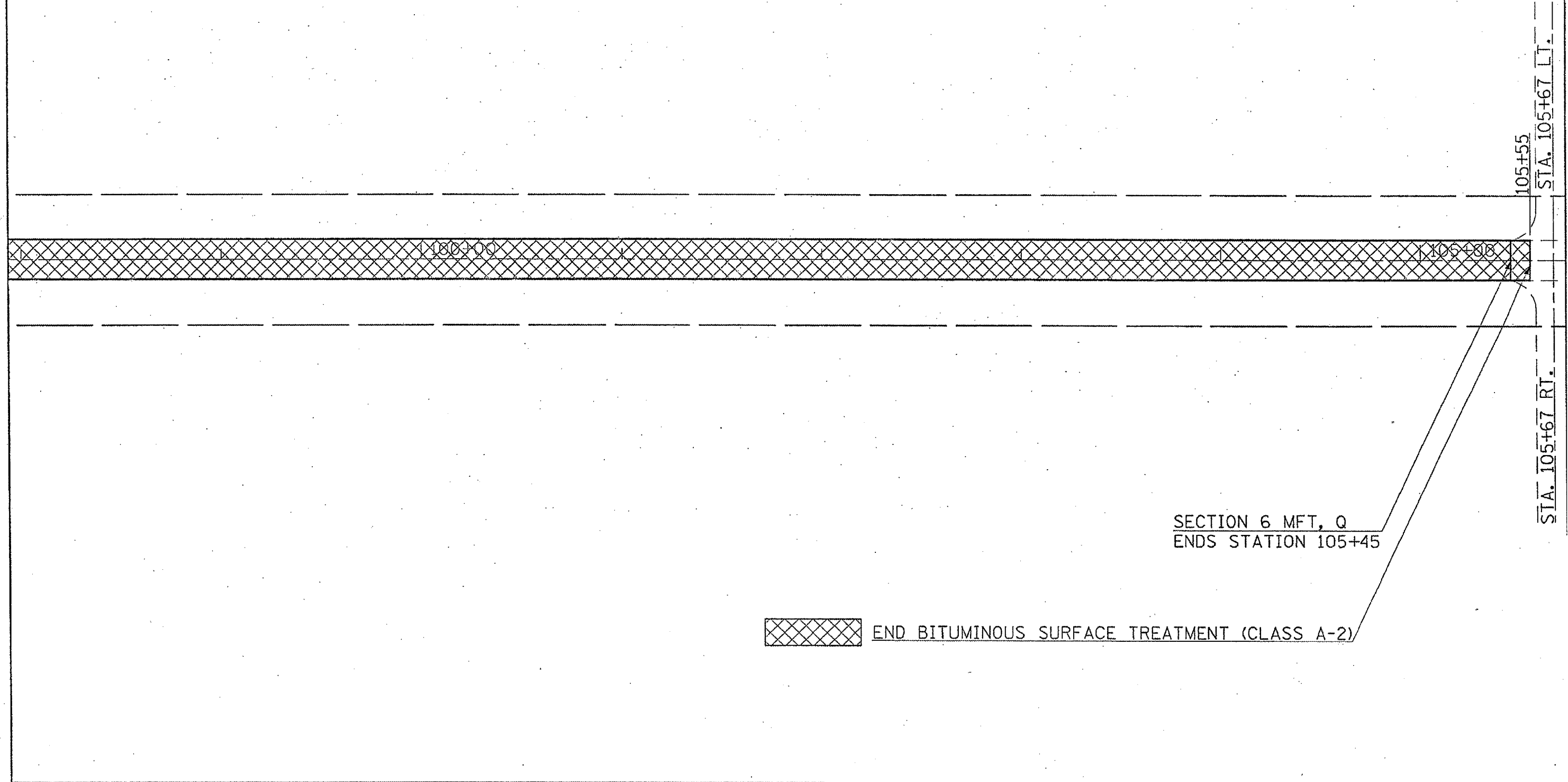
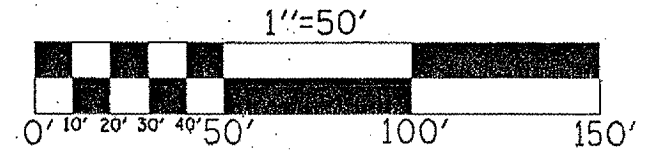

SECTION 6 MFT, Q
ENDS STATION 105+45

 END BITUMINOUS SURFACE TREATMENT (CLASS A-2)

F.A.S. RTE.	SECTION	COUNTY	TOTAL SHEETS	SHEET NO.
1678	6 MFT, Q	EDGAR	29	24

CONTRACT NO. 70467

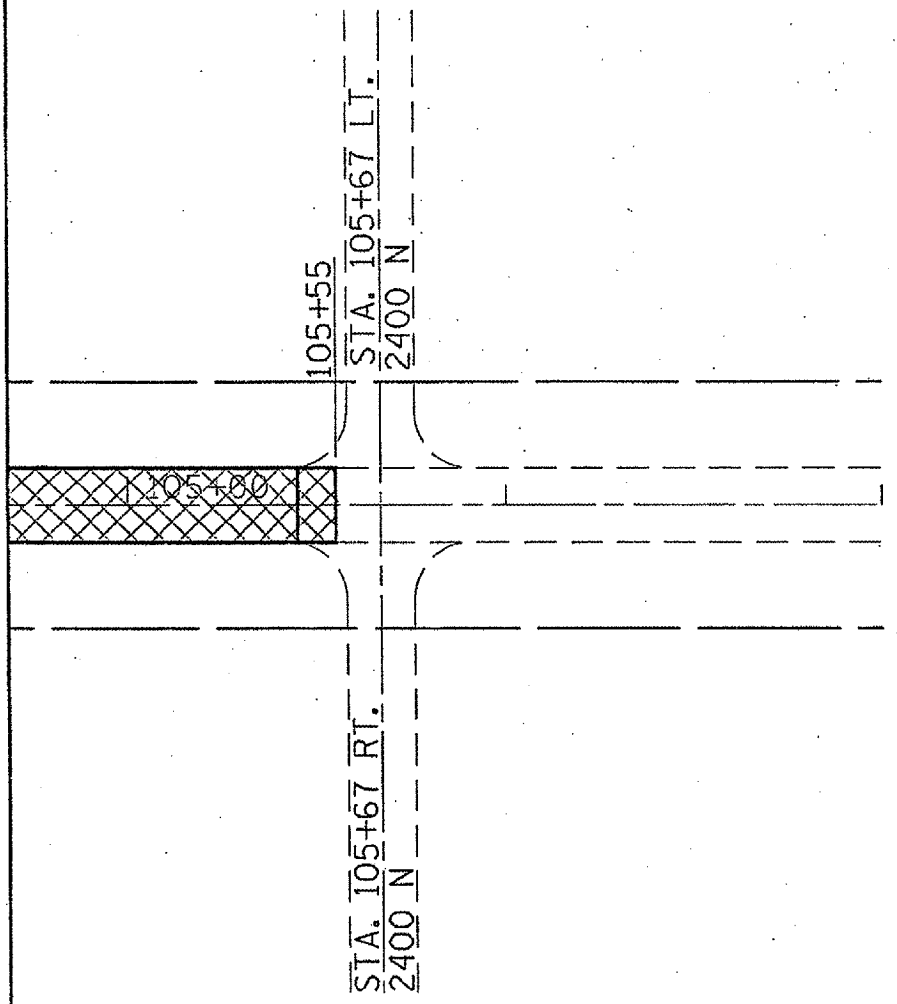
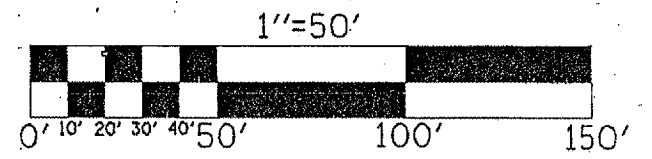

RUNDOWN DETAIL

F.A.S. RTE.	SECTION	COUNTY	TOTAL SHEETS	SHEET NO.
1678	6 MFT. Q	EDGAR	29	25

CONTRACT NO. 70467

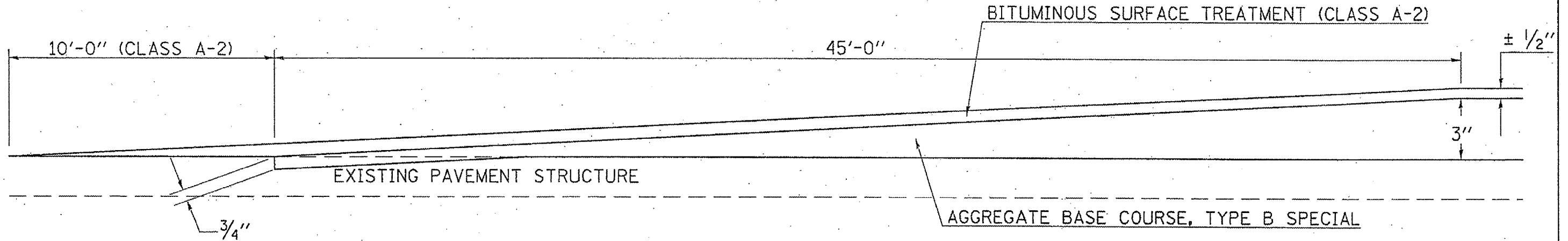

SIDEROADS

(BITUMINOUS OR OIL & CHIP)

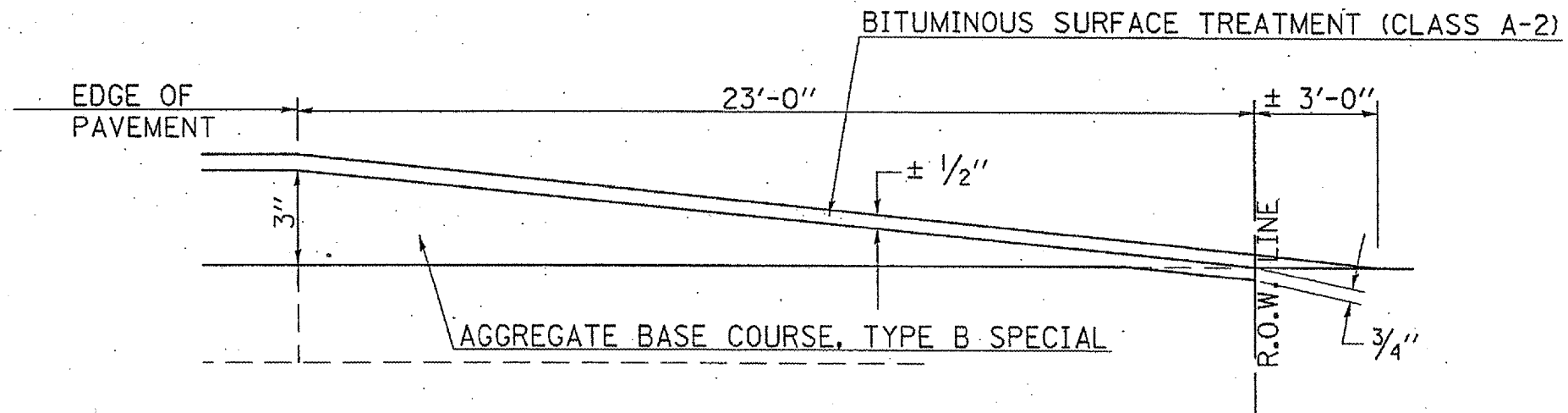

NOTE: THE BASE COURSE AND A-2 TREATMENT ARE INTENDED TO RESURFACE THE EXISTING SIDEROAD CONFIGURATIONS IN THEIR ENTIRETY.

PRIVATE OR COMMERCIAL ENTRANCES

(BITUMINOUS, OIL & CHIP, AGGREGATE OR EARTH)

F.A.S. RTE.	SECTION	COUNTY	TOTAL SHEETS	SHEET NO.
1678	6 MFT. Q	EDGAR	29	26

CONTRACT NO. 70467

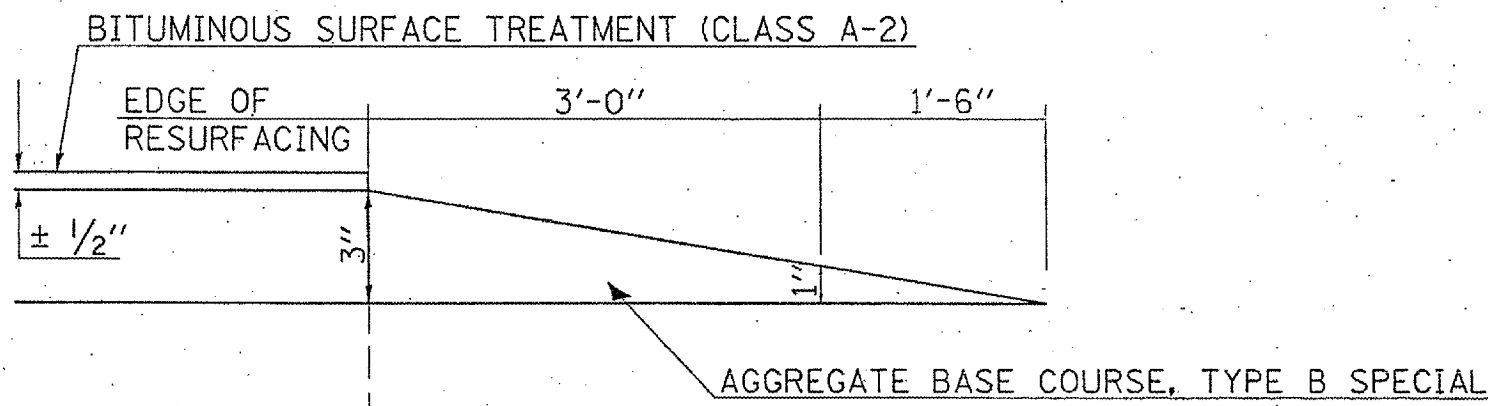

NOTE: THE BASE COURSE IS INTENDED TO RESURFACE THE EXISTING ENTRANCES IN THEIR ENTIRETY.

MAILBOX TURNOUTS

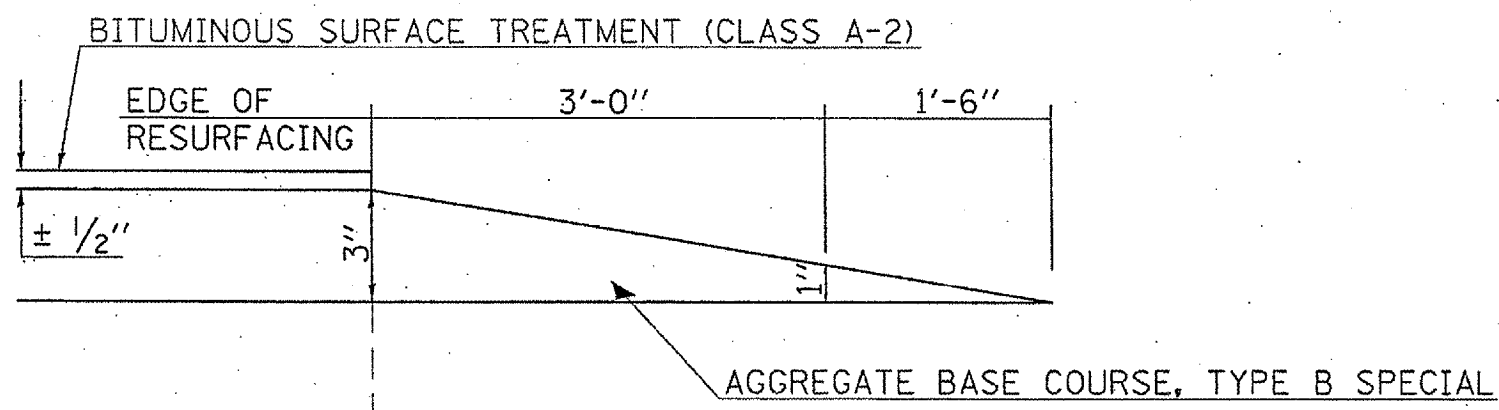

NOTE: THE BASE COURSE IS INTENDED TO RESURFACE THE EXISTING MAILBOX TURNOUTS IN THEIR ENTIRETY.

F.A.S. RTE.	SECTION	COUNTY	TOTAL SHEETS	SHEET NO.
1678	6 MFT, Q	EDGAR	29	27

CONTRACT NO. 70467

TYPICAL APPLICATIONS OF PAVEMENT MARKINGS AND MARKERS

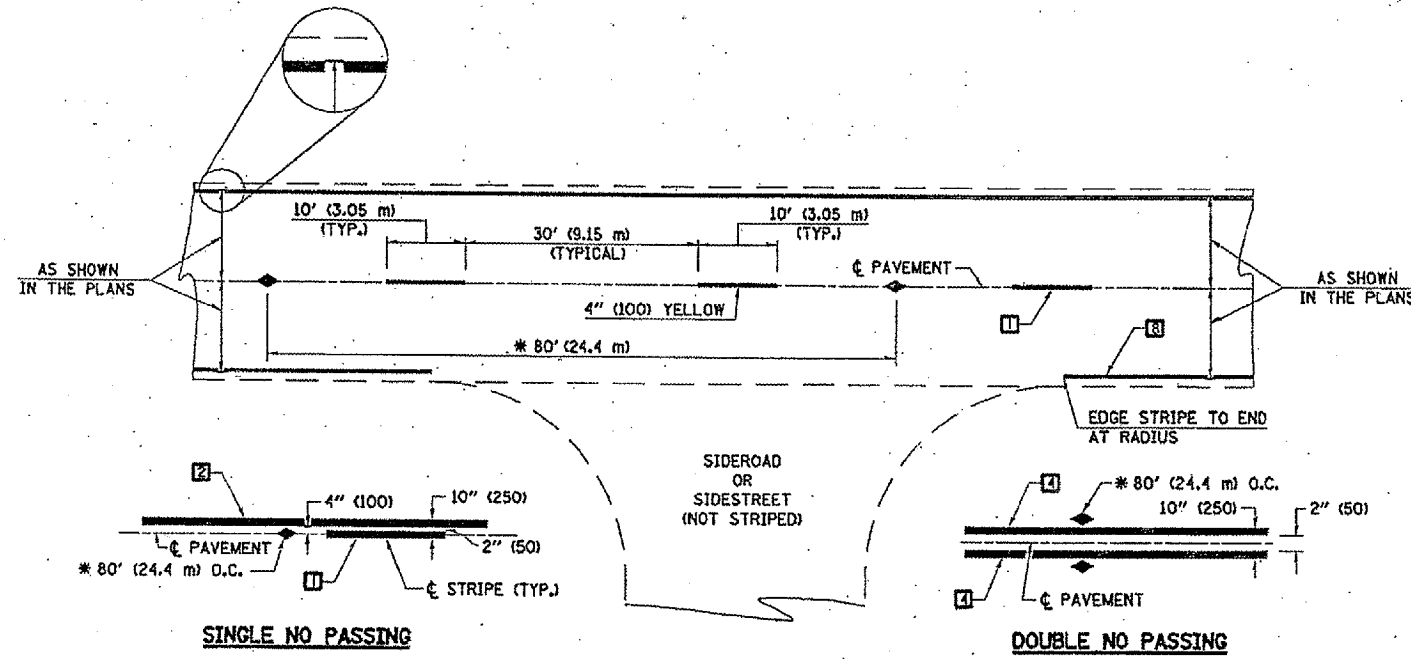

* REDUCE TO 40' (12.2 m) O.C. ON CURVES WITH POSTED OR ADVISORY SPEEDS OF 45 mph (70 km/h) OR LESS.

TYPICAL PAVEMENT MARKING LEGEND

- 1 4" (100) SKIP-DASH (YELLOW)
- 2 4" (100) SOLID (YELLOW)
- 3 12" (300) DIAGONAL (YELLOW)
- 4 4" (100) DOUBLE YELLOW (NARROW)
- 5 RESERVED
- 6 RESERVED
- 7 4" (100) SKIP-DASH (WHITE)
- 8 4" (100) SOLID (WHITE)
- 9 12" (300) DIAGONAL (WHITE)
- 10 6" (150) CROSS WALK (WHITE)
- 11 24" (600) STOP BAR (WHITE)
- 12 8" (200) SOLID (WHITE)
- 13 4" (100) LANE LINE EXTENSIONS (WHITE)
- 14 4" (100) PARKING WHITE

TYPICAL PAVEMENT MARKERS LEGEND

- ◆ TWO-WAY AMBER MARKER
- ▶ ONE-WAY AMBER MARKER
- ▷ ONE-WAY CRYSTAL MARKER

DETAIL OF RURAL LEFT TURN LANE

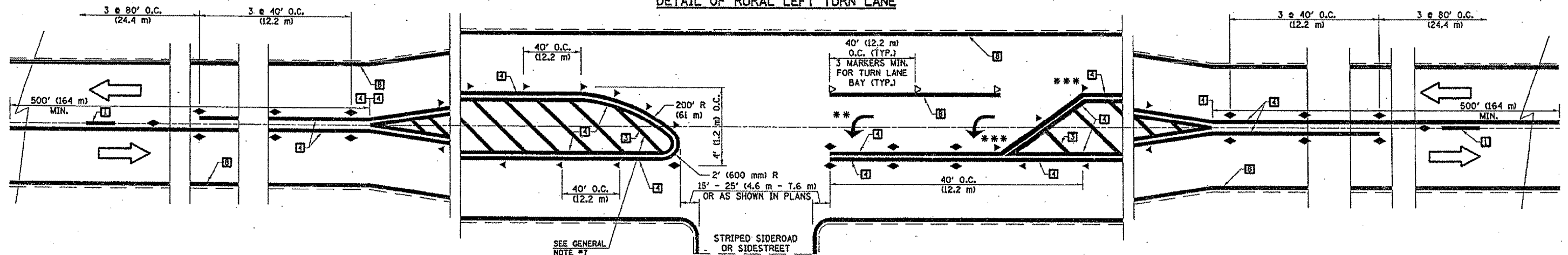

*** REDUCE SPACING IF NECESSARY TO ASSURE MARKERS AT CORNER POINTS.
 ** TURN ARROWS SHALL BE PLACED AS SHOWN ON SHEET #2.

SHEET 1 OF 3

DESIGNED	NAME	DATE	REVISIONS
J.M.H.	J.M.H.	5/85	
CHECKED	F.S.	6/85	
CADD NO.	F-5.25		

ALL DIMENSIONS ARE IN INCHES (MILLIMETERS) UNLESS OTHERWISE SHOWN.

F.A.S. RTE.	SECTION	COUNTY	TOTAL SHEETS	SHEET NO.
1678	6 MFT. Q	EDGAR	29	28

CONTRACT NO. 70467

TYPICAL APPLICATIONS OF PAVEMENT MARKINGS AND MARKERS

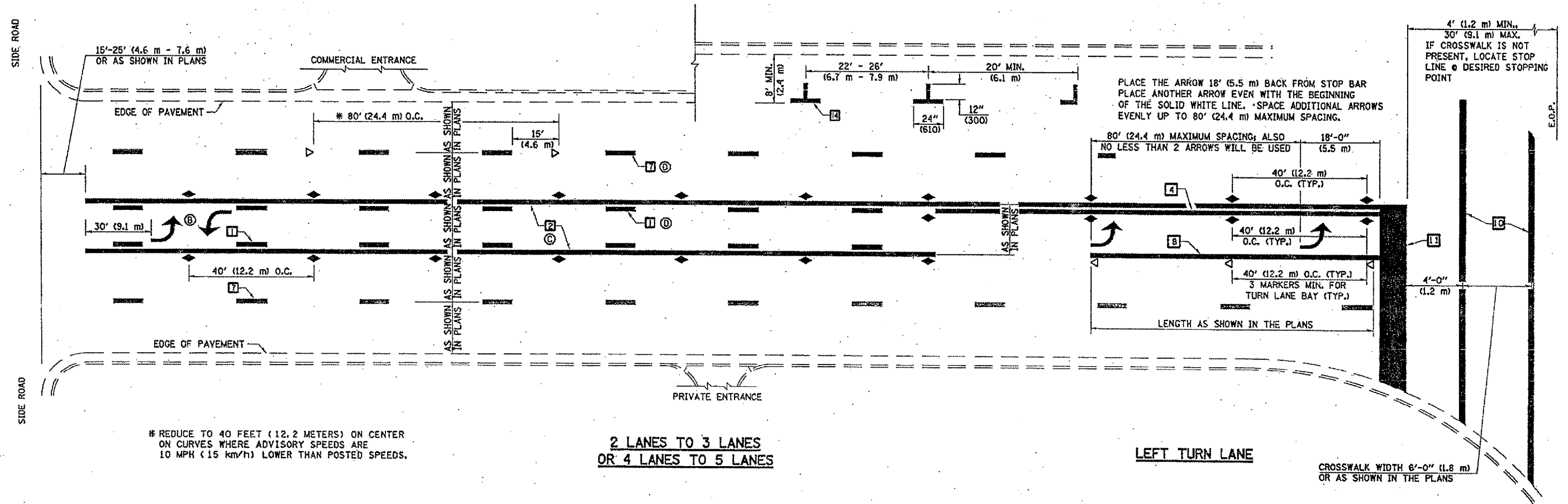

* REDUCE TO 40 FEET (12.2 METERS) ON CENTER ON CURVES WHERE ADVISORY SPEEDS ARE 10 MPH (15 km/h) LOWER THAN POSTED SPEEDS.

**2 LANES TO 3 LANES
OR 4 LANES TO 5 LANES**

LEFT TURN LANE

CROSSWALK WIDTH 6'-0" (1.8 m)
OR AS SHOWN IN THE PLANS

SHEET 2 OF 3

DESIGNED	NAME	DATE	REVISIONS
J.M.H.	J.M.H.	5/85	NAME
F.H.S.	F.H.S.	6/88	DATE
CHECKED	NAME	DATE	
FTD	GEOMETRICS/K.A.G.	07/02	
CADD NO.	F-5.25	K.A.G.	08/04

ALL DIMENSIONS ARE IN INCHES (MILLIMETERS) UNLESS OTHERWISE SHOWN.

F.A.S. RTE.	SECTION	COUNTY	TOTAL SHEETS	SHEET NO.
1678	6 MFT, Q	EDGAR	29	29

CONTRACT NO. TQ467

TYPICAL APPLICATIONS OF PAVEMENT MARKINGS AND MARKERS

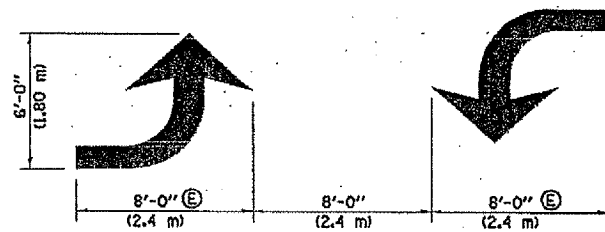

TYPICAL DOUBLE TURN ARROWS (WHITE)

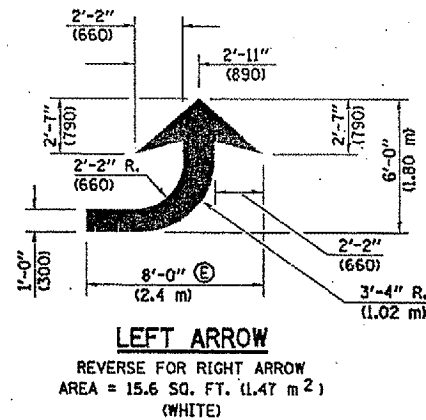

LEFT ARROW
REVERSE FOR RIGHT ARROW
AREA = 15.6 SQ. FT. (1.47 m²)
(WHITE)

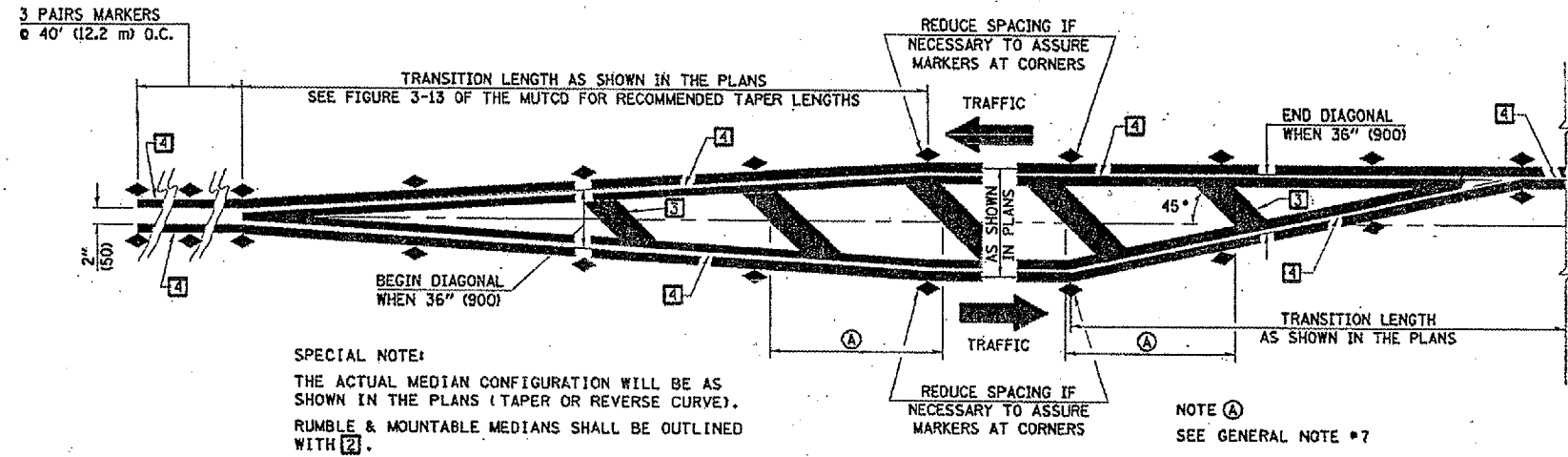

SPECIAL NOTE:
THE ACTUAL MEDIAN CONFIGURATION WILL BE AS SHOWN IN THE PLANS (TAPER OR REVERSE CURVE).
RUMBLE & MOUNTABLE MEDIANS SHALL BE OUTLINED WITH [2].

NOTE (A)
SEE GENERAL NOTE # 7

TYPICAL MEDIAN TRANSITIONS

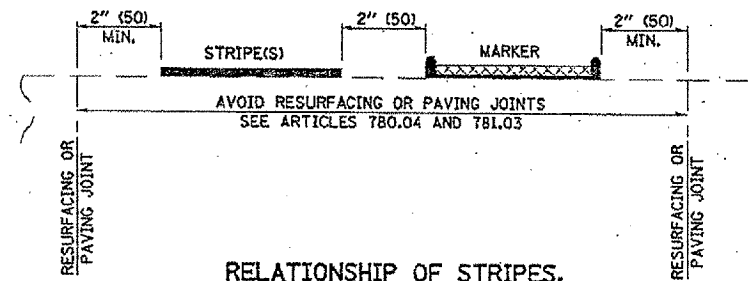

RELATIONSHIP OF STRIPES, MARKERS AND JOINTS

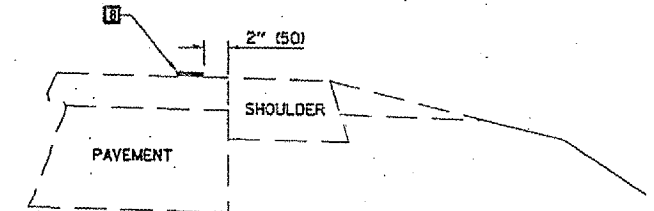

RELATIONSHIP OF EDGE STRIPE TO SAFETY SHOULDER OR PAVED SURFACE

SPECIAL NOTES:

- Ⓒ TURN ARROW PAIRS SHALL BE PLACED AT 250' (75 m) INTERVALS AND SHALL BE EVENLY SPACED BETWEEN BOTH ENDS OF THE BIDIRECTIONAL LEFT TURN LANE.
- Ⓒ THE SOLID YELLOW PAVEMENT MARKINGS [2] SHOULD GENERALLY START OR END NEAR THE RADIUS POINT OF EACH STREET RETURN EXCEPT WHERE ONE OR BOTH ENDS WOULD INCLUDE STOP BARS.
- Ⓒ THE SKIP-DASH PAVEMENT MARKINGS [1] OR [7] SHOULD BE CENTERED BETWEEN BOTH ENDS OF EACH CITY BLOCK AND SHALL BE PLACED SO THEY LINE UP ACROSS FROM EACH OTHER. SEE EXAMPLE ON SHEET 2 OF 3.
- Ⓒ TURN ARROW SIZE DEPENDS ON THE LOCATION.
RURAL LOCATION - LARGE ARROW SIZE
URBAN LOCATION - SMALL ARROW SIZE

GENERAL NOTES

- 1. WHEN MEDIANS ARE PRESENT, PAVEMENT MARKINGS ARE TO BE PLACED ADJACENT TO MEDIANS.
- 2. SCALE: NONE
- 3. SOME OF THE INFORMATION INCLUDED WITH THIS DETAIL MAY NOT BE APPLICABLE TO THIS IMPROVEMENT.
- 4. PAVEMENT MARKINGS ARE TO BE EXTENDED THROUGH OMISSIONS WHEN APPLICABLE.
- 5. A STRIPING KEY IS AVAILABLE ELSEWHERE AND SHALL BE SHOWN WHERE THE QUANTITIES ARE LISTED.
- 6. FINAL PAVEMENT MARKINGS SHALL BE IN PLACE PRIOR TO PLACING ANY RAISED REFLECTIVE PAVEMENT MARKERS.
- 7. THE FOLLOWING CRITERIA SHALL BE USED FOR SELECTING THE DIAGONAL PAVEMENT MARKING SPACING.
< 30 MPH USE 15' (< 50 km/h USE 4.5 m)
30-45 MPH USE 20' (50-75 km/h USE 6.0 m)
> 45 MPH USE 30' (> 75 km/h USE 9.0 m)

SHEET 3 OF 3

DESIGNED	NAME	DATE	REVISIONS
J.M.H.	J.M.H.	5/85	
CHECKED	F.S.	6/28	
CADD NO.	F-5.25	6/28	

ALL DIMENSIONS ARE IN INCHES (MILLIMETERS) UNLESS OTHERWISE SHOWN.