

STATE OF ILLINOIS  
DEPARTMENT OF TRANSPORTATION

ROUTE NO.	SECTION	COUNTY	TOTAL SHEETS	SHEET NO.
		Cook	14	7
FED. ROAD DIST. NO. 7		ILLINOIS	FED. AID PROJECT-	

SHEET NO. 1  
4 SHEETS

Contract Number: 62912

**GENERAL NOTES**

Plan dimensions and details relative to existing structure have been taken from existing plans and are subject to nominal construction variations. It shall be the Contractor's responsibility to verify such dimensions and details in the field and make necessary approved adjustments prior to construction or ordering of materials. Such variations shall not be cause for additional compensation for a change in the scope of the work, however, the Contractor will be paid for the quantity actually furnished at the unit price bid for the work.

Any damage done to the bridge during beam removal shall be repaired by the Contractor. Cost to be included in the cost of "Removal of Existing P.P.C. Deck Beams".

Reinforcement bars shall conform to the requirements of AASHTO M 31 or M 322 Grade 60.

The top surface of the beams shall be finished in accordance with Article 504.06 of the Standard Specifications except that the surface shall not be roughened by brooming. The finished surface shall be free of depressions or high spots with sharp corners, and the top edge of keys shall be rounded or chamfered a minimum of 1/4".

Temporary concrete barrier shall only be anchored into the overlay and not the PPC Deck Beams.

Existing reinforcement extending into the removal area shall be cleaned, straightened and incorporated into the new construction.

Any reinforcement bars that are damaged during concrete removal shall be replaced with an approved bar splicer or anchorage system. Cost shall be included with Concrete Removal.

**TOTAL BILL OF MATERIAL**

ITEM	UNIT	QUANTITY
Bituminous Concrete Surface Removal	Sq. Yd.	10.6
Waterproofing Membrane System	Sq. Yd.	51.8
Removal of Existing PPC Deck Beams	Sq. Ft.	575
Bituminous Concrete Surface Course, Superpave, Mix "D", N 50	Tons	7.5
PC Mortar Fairing Course	Foot	268
PPC Deck Beams (21" Depth)	Sq. Ft.	569
Concrete Superstructure	Cu. Yd.	13.5
Protective Coat	Sq. Yd.	44.7
Concrete Removal	Cu. Yd.	5.9
Reinforcement Bars, Epoxy Coated	Pound	1410
Asbestos Bearing Pad Removal	Each	2
Removing and Re-Erecting Existing Railing	Foot	78

**DESIGN STRESSES  
PRESTRESS UNITS**

$f'_c = 5000$  psi  
 $f'_{ci} = 4000$  psi  
 $f'_s = 270000$  psi (1/2" low lax strands)  
 $f'_{si} = 201960$  psi (1/2" low lax strands)

**PLAN AND ELEVATION**  
**F.A.P. RT. 343**  
**COOK COUNTY**  
**SN 016-0525**

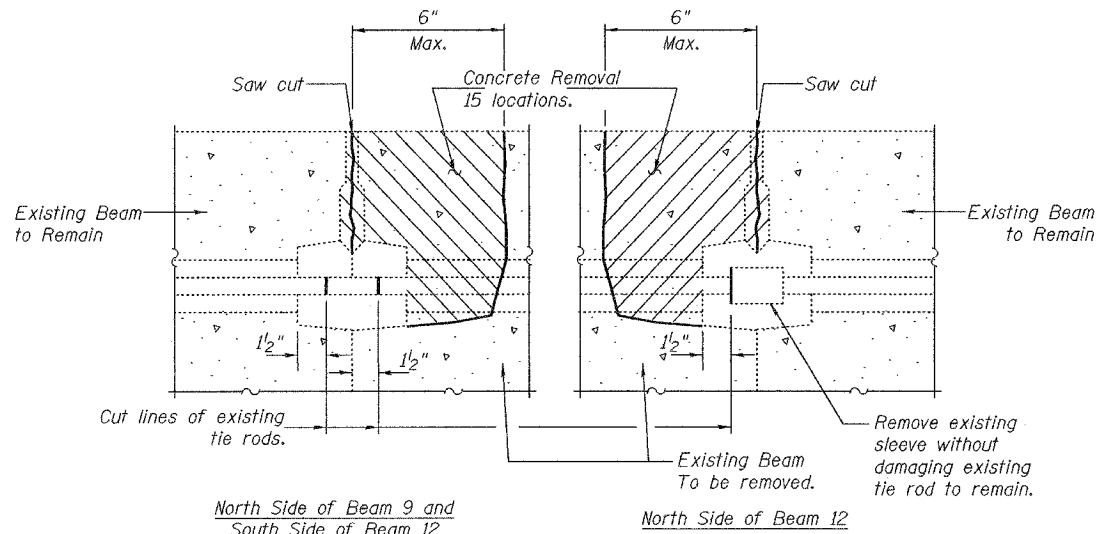

**BEAM REMOVAL DETAIL  
AT TRANSVERSE TIES**

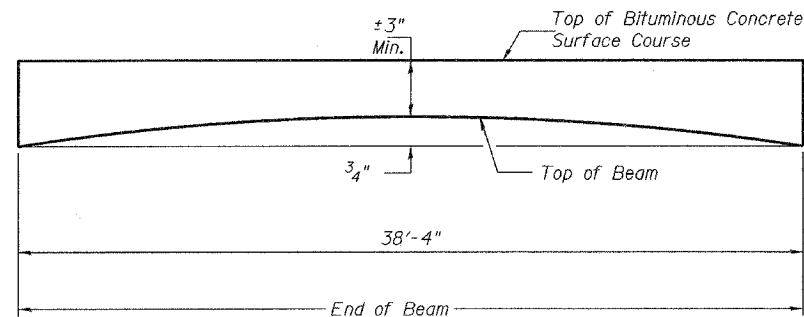

**ANTICIPATED INITIAL CAMBER DIAGRAM**

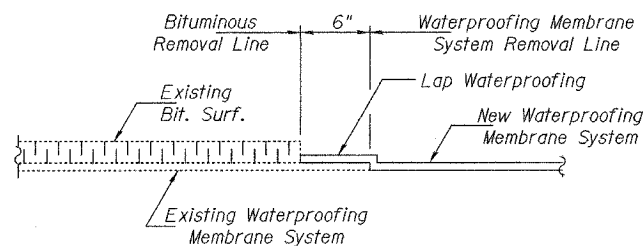

**WATERPROOFING TREATMENT**

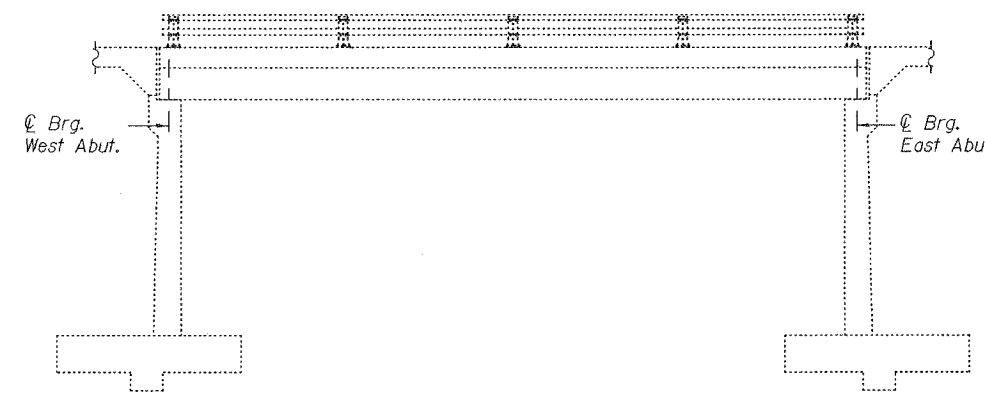

**ELEVATION**

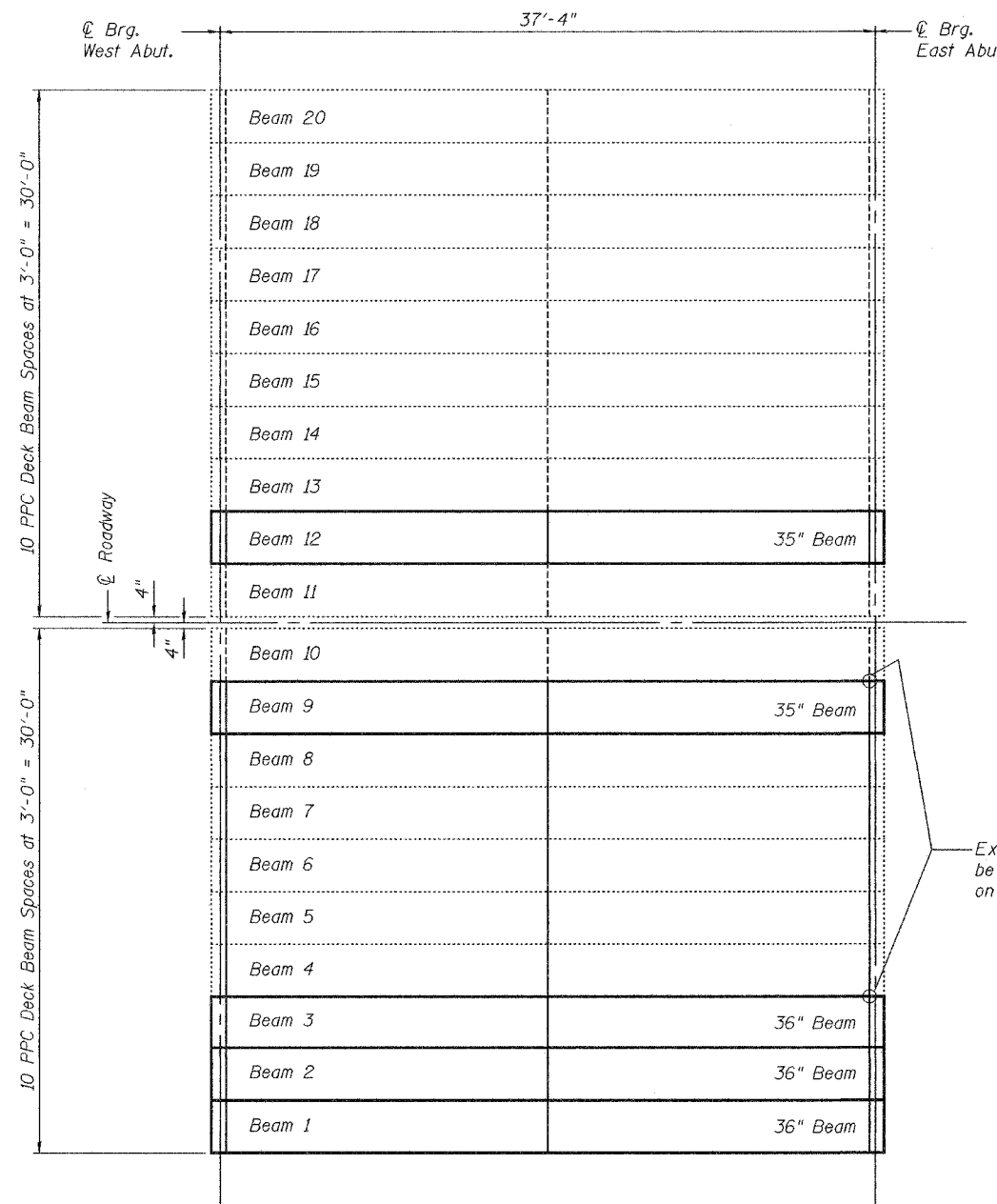

**PLAN**

DESIGNED	Vicor H. Veliz
CHECKED	[Signature]
DRAWN	[Signature]
CHECKED	VHV / S.J.B.

EXAMINED	John A. Morias ENGINEER OF STRUCTURAL SERVICES
PASSED	Ralph E. Adams ENGINEER OF BRIDGES AND STRUCTURES



Expires: November 30, 2006

