

**SOUTH ABUTMENT ELEVATION
(LOOKING SOUTH)**

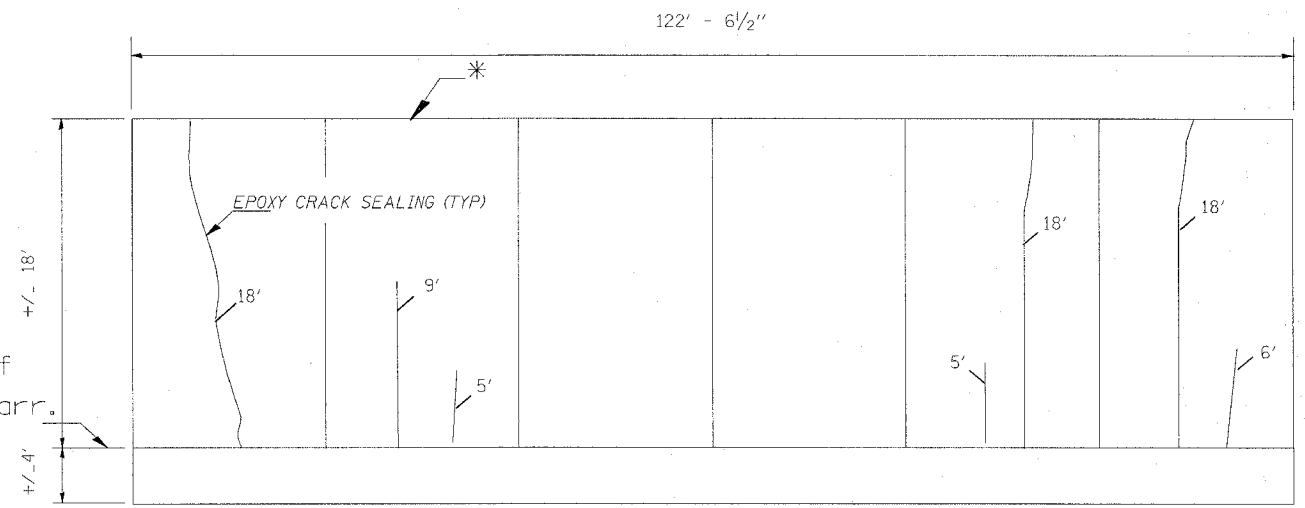

**NORTH ABUTMENT ELEVATION
(LOOKING NORTH)**

* Clean existing abutment seals before concrete is placed. Cost included w/ Concrete Superstructure.

BILL OF MATERIAL

ITEM	UNIT	QUANTITY
DECK SLAB REPAIR (FULL DEPTH TYPE II)	SQ YD	16
EPOXY CRACK SEALING	FOOT	121

Notes:
Patching not necessary within 3'-4 1/4" of end of existing deck.
Areas of deck repairs are estimated. The Engineer shall show actual locations of deck repairs on As-built Plans.

LEGEND

- DECK SLAB REPAIR (FULL DEPTH)
- DECK SLAB REPAIR (PARTIAL DEPTH) APPROX. QTY= 62 SQ YD COST INCLUDED IN "BRIDGE DECK HYDRO-SCARIFICATION"

DATE OF SURVEY = 10-1-2004

REVISIONS	
NAME	DATE

ILLINOIS DEPARTMENT OF TRANSPORTATION
DECK PATCH AND CRACK SEALING
LOC 1: US 12/ 45 OVER IL 64
SN 016-0336

SCALE: VERT. DRAWN BY
 HORIZ. CHECKED BY
DATE 4/18/2005