

no.	date	by	ckd	description
0	04/25/08	BJQ	MAR	ISSUED FOR BID

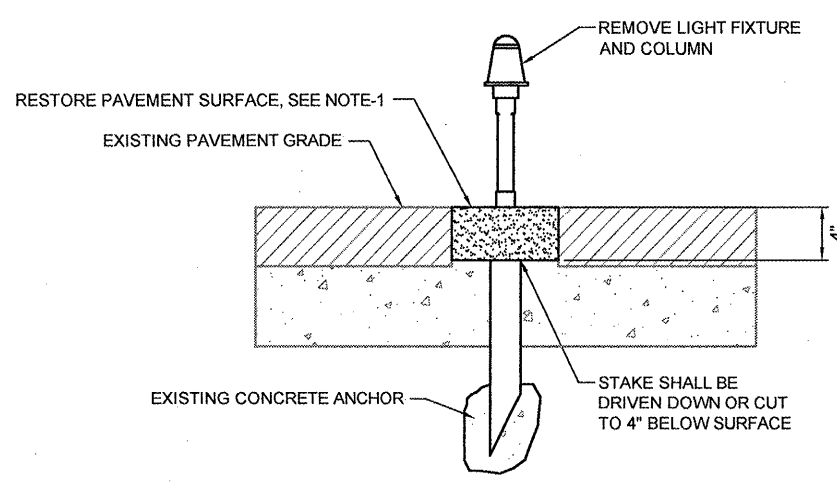

**STAKE MOUNTED LIGHT REMOVAL**  
**DETAIL**  
 NOT TO SCALE

- NOTES:**
1. RESTORATION OF PAVEMENT SURFACE SHALL BE CONSIDERED INCIDENTAL TO EXISTING STAKE MOUNTED LIGHT REMOVAL.
  2. ALL REMOVED LIGHT ASSEMBLIES AND ISOLATION TRANSFORMERS SHALL BE TURNED OVER TO THE AIRPORT MANAGER UNLESS OTHERWISE DIRECTED.

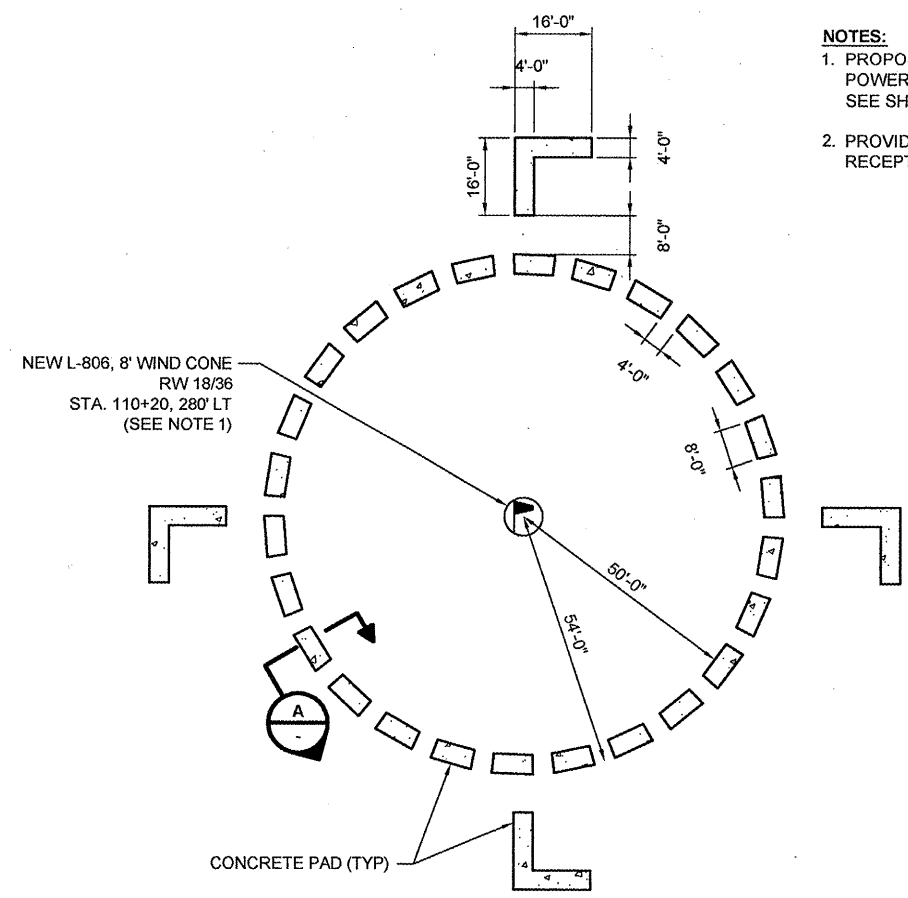

- NOTES:**
1. PROPOSED WIND CONE SHALL BE 120VAC POWERED. SEE SHEET E105 FOR LOCATION AND SEE SHEET E204 FOR INSTALLATION DETAILS.
  2. PROVIDE LOCAL DISCONNECT, 120V, WP/GFCI RECEPTACLE AND PHOTO CELL ON WIND CONE.

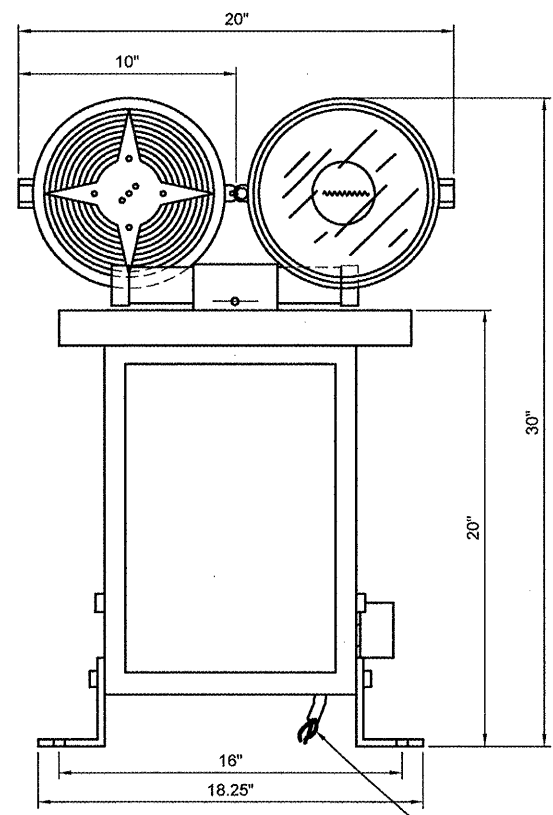

- NOTES:**
1. PROPOSED BEACON SHALL BE HALI-BRITE MODEL HBM-175/2 (OR EQUAL) BEACON SHALL BE L-801A, CLASS 2.
  2. DIMENSIONS SHOWN ON THIS DETAIL SHALL BE VERIFIED WITH MANUFACTURER.
  3. CONTRACTOR SHALL REMOVE EXISTING BEACON AND INSTALL NEW BEACON IN IT'S PLACE ON EXISTING BEACON TOWER. CONTRACTOR SHALL PROVIDE ALL NECESSARY HARDWARE FOR A COMPLETE AND OPERATIONAL BEACON TO THE SATISFACTION OF THE ENGINEER.
  4. CONTRACTOR SHALL RE-CONNECT EXISTING ELECTRIC SERVICE AND GROUNDING SYSTEM TO PROPOSED BEACON/WIRING.
  5. BEACON LAMPS SHALL BE 175W, METAL HALIDE. CONTRACTOR SHALL PROVIDE ONE SPARE SET OF LAMPS TO OWNER FOR FUTURE REPLACEMENT.

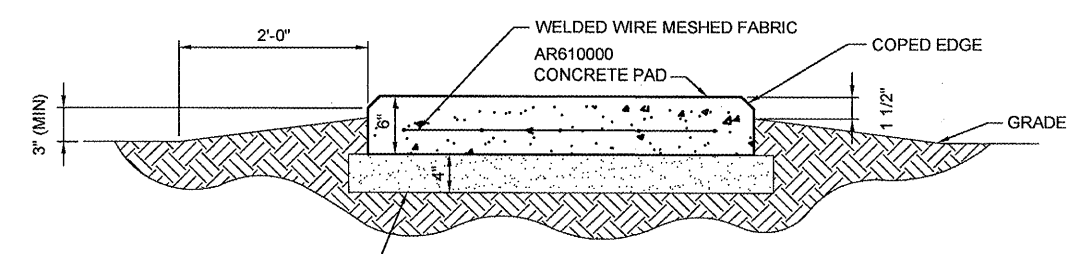

**SECTION**  
 NOT TO SCALE

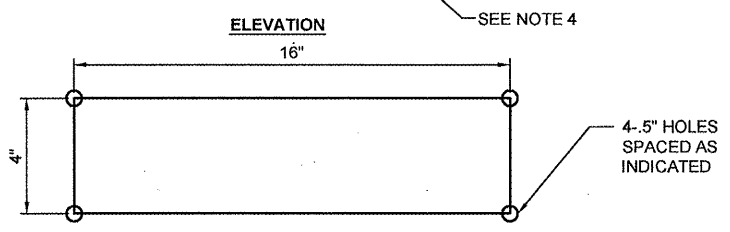

**BEACON**  
**DETAIL**  
 NOT TO SCALE

**SEGMENTED CIRCLE AND WIND CONE**  
**DETAIL**  
 NOT TO SCALE



date	02/13/08	detailed	L. TUCKER
designed	B. QUINLAN	checked	A. RAHMAN

**RUNWAY 9/27 LIGHTING, NAVAIDS AND SIGNAGE; RUNWAY 18/36 WIND CONES AND SIGNAGE**

**ELECTRICAL DETAILS 2**

project	contract
drawing	rev.
<b>E202</b>	<b>0</b>
sheet 16	of 21 sheets
file 47463E202.dwg	

Scale For Microfilming  
 Millimeters  
 Inches

COPYRIGHT © 2008 BURNS & MCDONNELL ENGINEERING COMPANY, INC.