

STATE OF ILLINOIS  
DEPARTMENT OF TRANSPORTATION

ROUTE NO.	SECTION	COUNTY	SHEET NO.	SHEET NO.
F.A.P. 304	5BR-2	CALHOUN	28	28 SHEETS
FED. ROAD DIST. NO. 7	ILLINOIS	FED. AID PROJECT		

Contract #76948

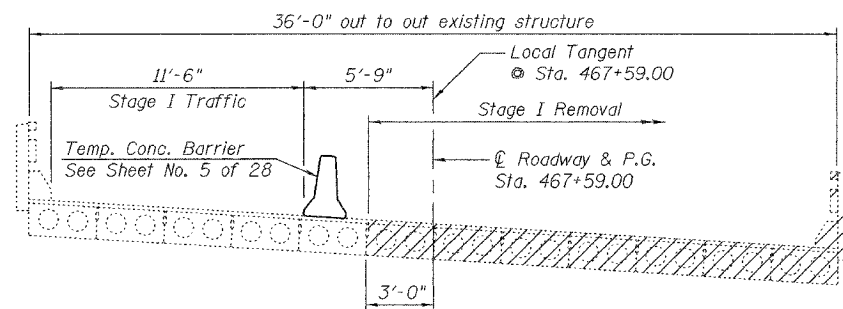

**STAGE I REMOVAL**  
(Looking upstation)

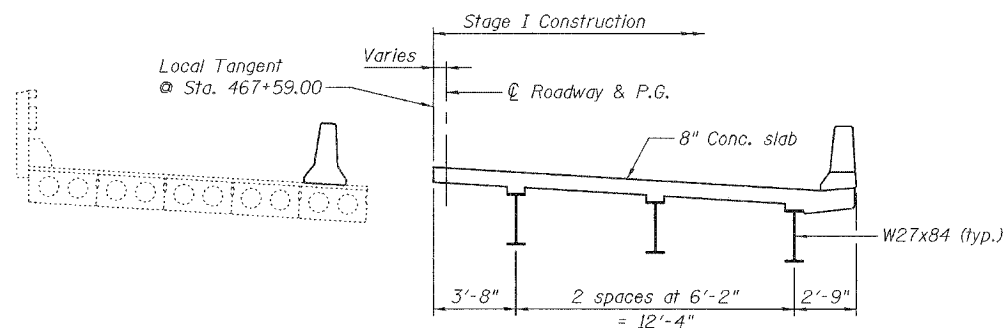

**STAGE I CONSTRUCTION**  
(Looking upstation)

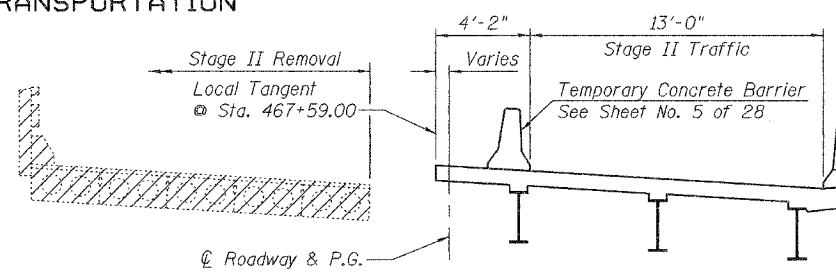

**STAGE II REMOVAL**  
(Looking upstation)

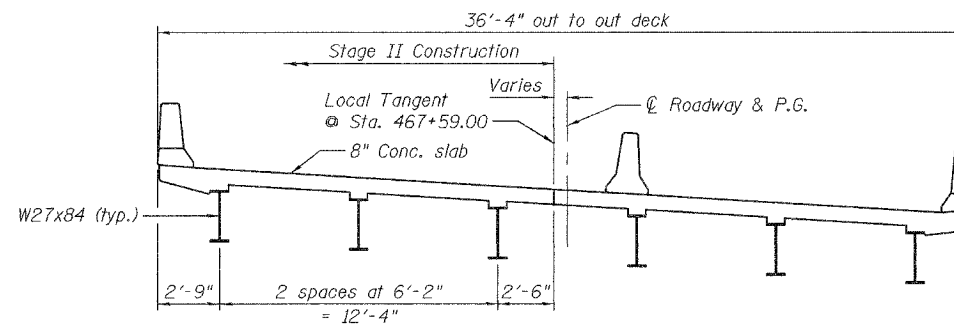

**STAGE II CONSTRUCTION**  
(Looking upstation)

Notes:  
Excavation behind existing abutment walls shall be performed to balance front and back soil pressure before removing the existing superstructure. The Contractor shall sawcut the upper portion of the existing abutment at the stage removal line before Stage I removal to ensure the remaining portion will not be prematurely damaged.

If the Contractor chooses to alter the temporary cantilevered sheet piling design requirements shown on the plans, a design submittal including plan details and calculations will be required for review and acceptance by the Engineer.

The Contractor shall connect the first sheet to the existing abutment wall to ensure stability of sheets driven to the top of the existing footing. This connection shall be reviewed and accepted by the Engineer and included in the cost for Temporary Sheet Piling.

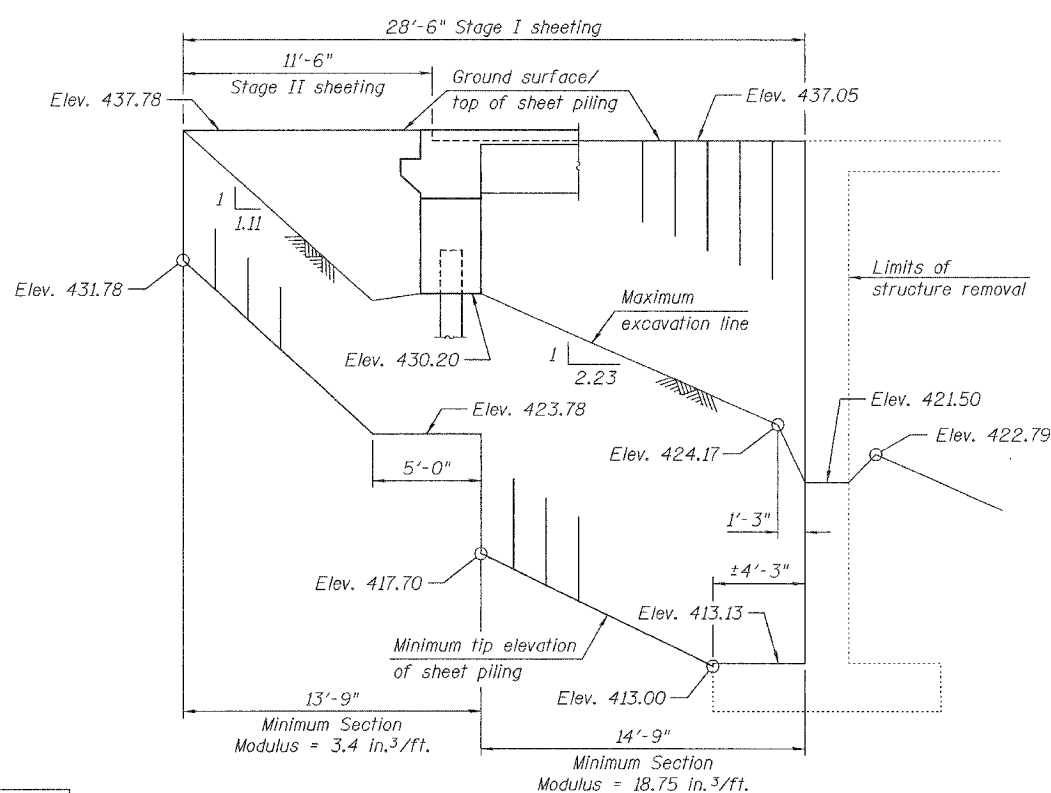

**TEMPORARY SHEET PILING**  
(at South Abutment)

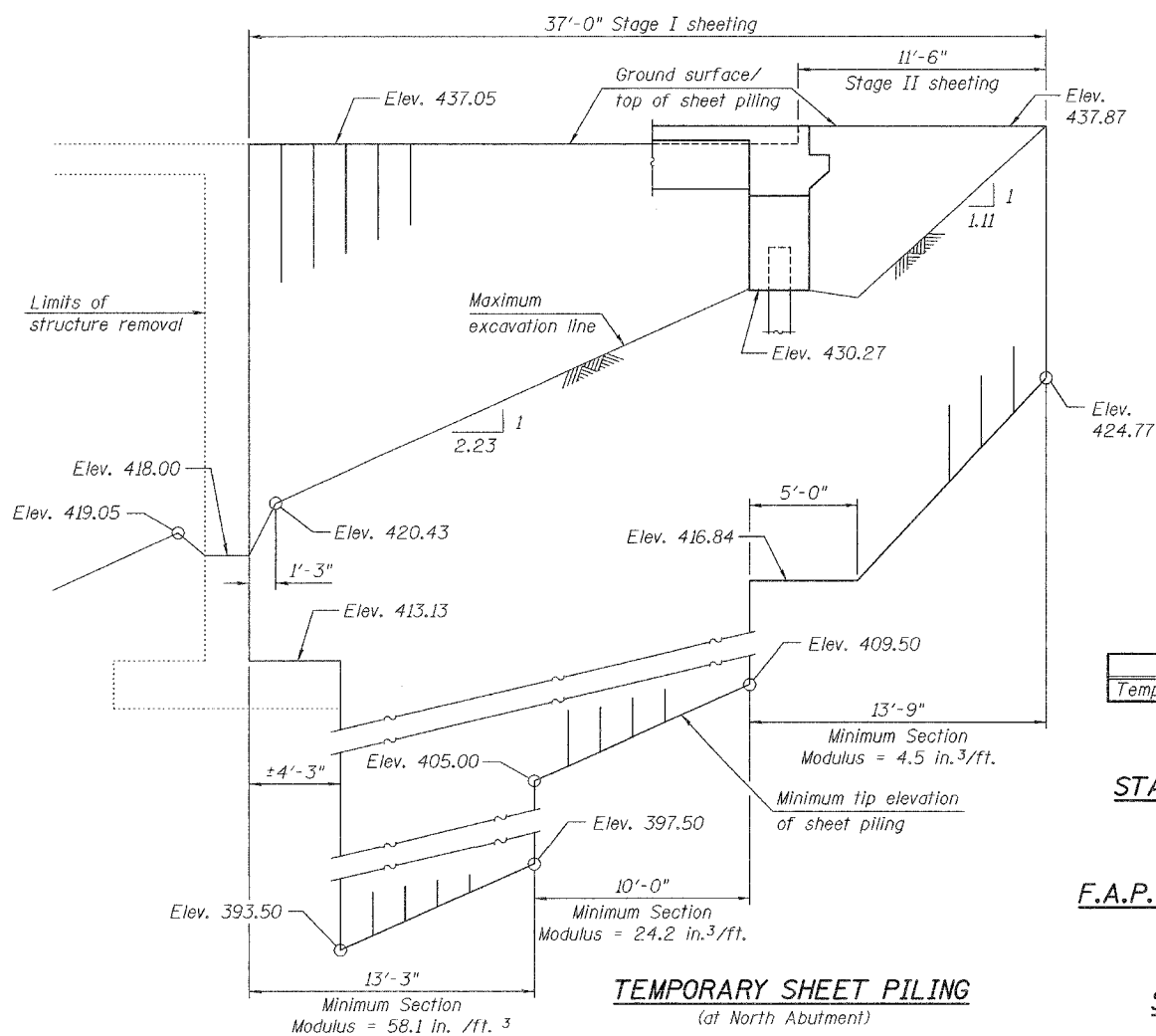

**TEMPORARY SHEET PILING**  
(at North Abutment)

**BILL OF MATERIAL**

Item	Unit	Total
Temporary Sheet Piling	Sq. Ft.	673

**STAGE CONSTRUCTION DETAILS**  
**IL. ROUTE 100 OVER**  
**CRAWFORD CREEK**  
**F.A.P. ROUTE 304 - SECTION 5BR-2**  
**CALHOUN COUNTY**  
**STATION 467+59.00**  
**STRUCTURE NO. 007-0027**

DESIGNED	YSS
CHECKED	RLM
DRAWN	PRC
CHECKED	RLM



02/27/08