

SUGGESTED INSTALLATION SEQUENCE

(SEE ALSO SECTION 284 OF THE STANDARD SPECIFICATIONS)

- INDIVIDUALLY ASSEMBLE THE EMPTY GABION BASKET UNITS.
- POSITION THE INITIAL LINE OF EMPTY GABION BASKET UNITS ON THE PREPARED SURFACE IN A DIRECTION PERPENDICULAR TO STREAM FLOW. SECURE ADJOINING BASKETS AND PARTIALLY FILL TO PROVIDE ANCHORAGE AGAINST DEFORMATION AND DISPLACEMENT DURING FILLING OPERATIONS.
- POSITION AND SECURE THE REMAINING EMPTY GABION BASKET UNITS ON THE PREPARED SURFACE AS SHOWN ON THE PLANS.
- PLACE THE BASKETS IN TENSION AND STRETCH TO REMOVE ANY KINKS FROM THE FABRIC. STRETCH THE EMPTY GABION BASKET UNITS IN A MANNER THAT WILL PREVENT UNRAVELING.
- FILL THE BASKET UNITS IN STAGES TO PREVENT LOCALIZED DEFORMATION. INTERNAL CONNECTING WIRES SHALL BE INSTALLED BETWEEN STONE LAYERS TO CONNECT THE FRONT FACE OF THE BASKET UNIT TO THE BACK FACE. AT NO TIME SHALL ANY CELL BE FILLED TO A DEPTH EXCEEDING 12 INCHES MORE THAN THE ADJOINING CELL. THE MAXIMUM HEIGHT FROM WHICH THE STONE MAY BE DROPPED INTO THE BASKET SHALL BE 3 FT.
- TIGHTLY STRETCH THE LID OVER THE STONE FILL USING A LID CLOSING TOOL APPROVED BY THE MANUFACTURER. USING CROWBARS OR OTHER SINGLE POINT LEVERAGE BARS FOR LID CLOSING SHALL BE PROHIBITED. TIGHTLY SECURE THE LID TO THE FILLED BASKET ALONG ALL EDGES, ENDS AND INTERNAL CELL DIAPHRAMS.
- IN LIEU OF FILLING BASKETS IN PLACE, THE BASKETS MAY BE PREFILLED ON A LEVEL SURFACE AS INDICATED IN STEPS 5 AND 6. THE BASKETS CAN THEN BE LIFTED AND PLACED ON THE PREPARED SURFACE USING A MANUFACTURER'S APPROVED LIFTING TECHNIQUE. CARE SHALL BE TAKEN NOT TO ABRASE THE ZINC OR VINYL COATING OR PERMANENTLY DISTORT THE SHAPE OF THE BASKET IN TRANSPORTATION. ANY DAMAGE TO THE BASKETS SHALL BE REPAIRED AT THE CONTRACTOR'S EXPENSE TO THE SATISFACTION OF THE ENGINEER. BASKETS SHALL BE PLACED TIGHTLY AGAINST AND SECURED TO BASKETS ALREADY IN PLACE.
- WHERE A COMPLETE GABION UNIT CANNOT BE INSTALLED AS SHOWN ON THE PLANS BECAUSE OF SPACE LIMITATIONS, THE BASKET UNIT SHALL BE CUT, FOLDED AND WIRED TOGETHER TO SUIT EXISTING SITE CONDITIONS.

FABRIC OPENING
NOMINAL DIMENSIONS
3 1/4" x 4 1/2"

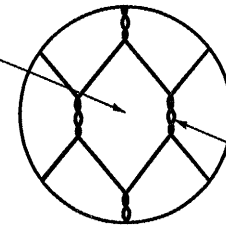

HEXAGONAL MESH
FABRIC WITH AT LEAST
THREE HALF TWISTS

NOTES:

- GABION BASKETS SHALL BE CONSTRUCTED OF A GALVANIZED, ALUMINIZED, OR PVC-COATED GALVANIZED OR ALUMINIZED STEEL WIRE.
- STEEL WIRE SHALL CONFORM TO SECTION 1006.35 OF THE STANDARD SPECIFICATIONS

GABION FABRIC DETAIL

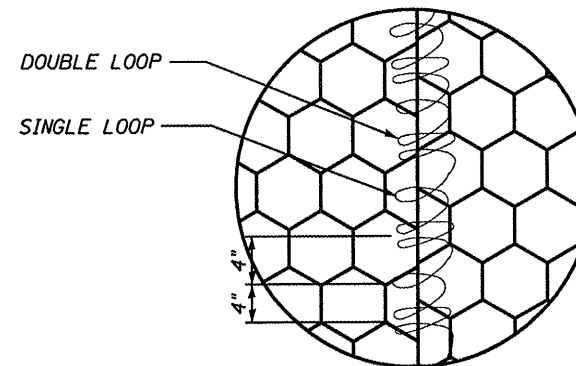

LACING DETAIL

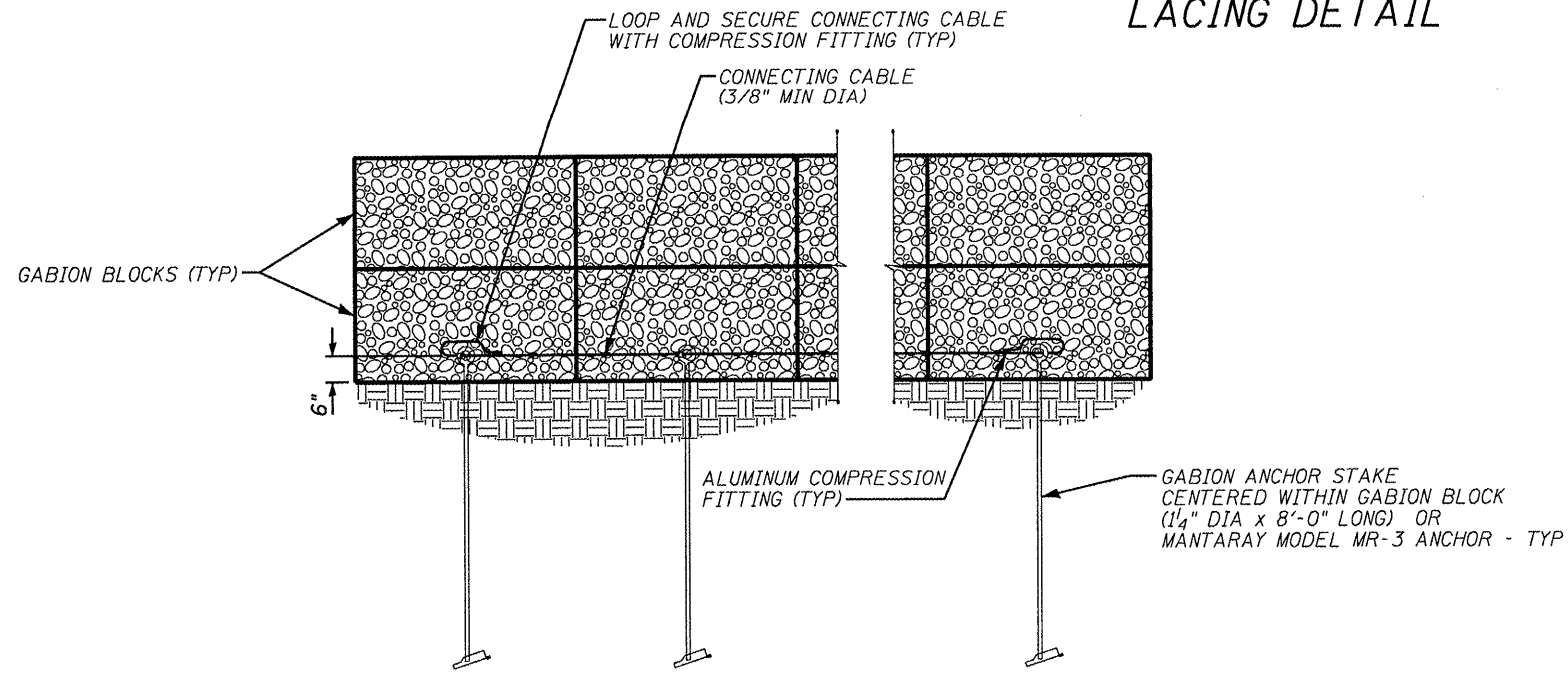

GABION ANCHOR STAKE SECURING DETAIL

ROUTE NO.	SECTION	COUNTY	TOTAL SHEETS	SHEET NO.
VAR	*	VAR	66	64
FED. ROAD DIST. NO. 4		ILLINOIS	FED. AID PROJECT	

* D4 SCOUR MITIGATION 2006

GABION BASKET NOTES:

- BASKETS SHALL BE OF SINGLE UNIT CONSTRUCTION. THE BASE, LID, ENDS AND SIDES SHALL BE EITHER WOVEN INTO A SINGLE UNIT OR ONE EDGE OF THESE MEMBERS CONNECTED TO THE BASE SECTION OF THE BASKETS. FOR PROPER ASSEMBLY, SEE LACING DETAIL.
- DIAPHRAMS SHALL EQUALLY DIVIDE BASKETS WHERE THE LENGTH OF THE BASKET EXCEEDS 1/2 IT'S HORIZONTAL LENGTH.
- GABION BASKET ASSEMBLY, INSTALLATION, FILLING AND LID-CLOSING SHALL BE IN ACCORDANCE WITH SECTION 284 OF THE STANDARD SPECIFICATIONS.

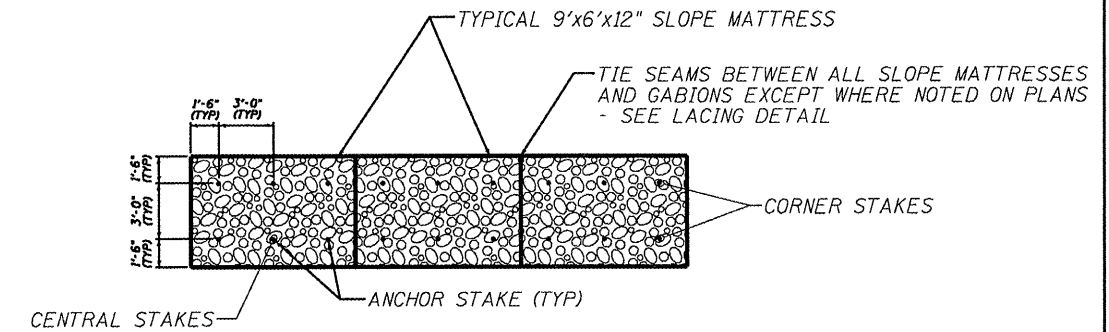

NOTES:

- ANCHOR STAKES SHALL BE PROVIDED IN ACCORDANCE WITH SECTION 284 OF THE STANDARD SPECIFICATIONS.
- ANCHOR STAKES ARE TO BE PLACED ON THREE-FOOT CENTERS, WITH AN ARRANGEMENT AS SHOWN ABOVE, FOR ALL SLOPE MATRESSES LAID ON A SLOPE OF 2:1 OR GREATER.
- ANCHOR STAKES FOR SLOPE MATRESSES LAID ON SLOPE LESS THAN 2:1 AND GREATER THAN 10% SHALL OMIT THE CENTRAL STAKES SHOWN ABOVE - 4 STAKES PER 6'x9' MATRESS.
- ALL SLOPE MATRESSES LAID ON SLOPES LESS THAN 10% SHALL NOT HAVE ANCHOR STAKES.

TYPICAL ANCHOR STAKE LAYOUT DETAIL

GABION LEGEND			
MARK	LENGTH	WIDTH	HEIGHT
A	6'	3'	3'
B	9'	3'	3'
C	12'	3'	3'
D	6'	3'	1 1/2'
G	6'	3'	1'
H	9'	3'	1'

ILLINOIS DEPARTMENT OF TRANSPORTATION

GABION DETAILS
SECTION D4 SCOUR
MITIGATION 2006
VARIOUS ROUTES
VARIOUS COUNTIES