

ELEVATION

SECTION B-B

DIMENSIONS

Location	A	B	C	D	E	F

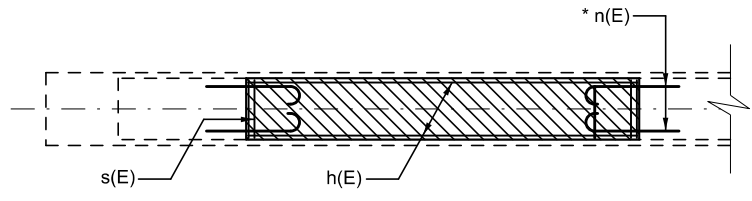

SECTION A-A

*Epoxy grout n(E) bars in 9" min. holes according to Article 584 of the Standard Specifications.

BILL OF MATERIAL

Bar	No.	Size	Length	Shape
h(E)	7	#5	'-"	—
n(E)		#5	'-"	⊂
s(E)		#5	'-"	⊂
Reinforcement Bars, Epoxy Coated			Pound	000
Concrete Structures			Cu. Yd.	00.0

GENERAL NOTES

Plan dimensions and details relative to existing plans are subject to nominal construction variations. The Contractor shall field verify existing dimensions and details affecting new construction and make necessary approved adjustments prior to construction or ordering of materials. Such variations shall not be cause for additional compensation for a change in scope of the work, however, the Contractor will be paid for the quantity actually furnished at the unit price bid for the work.

Reinforcement bars designated (E) shall be epoxy coated.

Reinforcement bars shall conform to the requirements of AASHTO M-31, M-42 or M-53 Grade 60.

The cost of epoxy grouting bars shall be included with reinforcement bars (epoxy coated).

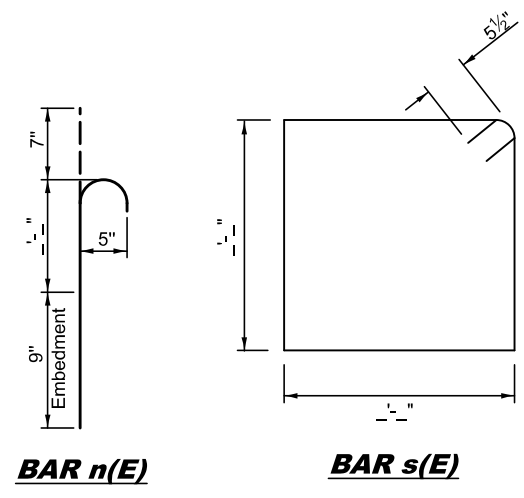

BAR n(E)

BAR s(E)

Revised per Structural Services Manual Section 2.7.7 Crashwall Extensions

Two Column Trapezoidal Pier Shown. (Multiple Columns Similar)

MODEL: XX002909B
FILE NAME: c:\pwworking\piper\personnel\0872377.D55\###-Sht-Detail_XX002909B.dgn

USER NAME = Bridgette.Pierson	DESIGNED - KJT	REVISED - KJT 5/2011
PLOT SCALE = 0.16666633' / in.	CHECKED -	REVISED - SWN 3/6/2017
PLOT DATE = 7/18/2024	DATE - 11/2006	REVISED - TJB 6/7/2022
		REVISED - TJB 7/17/2024

**STATE OF ILLINOIS
DEPARTMENT OF TRANSPORTATION**

CRASHWALL EXTENSION (TRAPEZOIDAL COLUMN PIER)

SCALE: SHEET 1 OF 1 SHEETS STA. TO STA.

DISTRICT 5 DETAIL NO. XX002909B				
F.A. RTE.	SECTION	COUNTY	TOTAL SHEETS	SHEET NO.
CONTRACT NO.				
ILLINOIS FED. AID PROJECT				