

MODEL: det 3 details  
 FILE: \\miller.pwllll.com\pww\benley.com\PI\DOT\Documents\DOT Offices\DH\dtr: 3\Projects\Carry Detail\03 Detail Rev\03 INCIDENTAL CONSTRUCTION.dgn

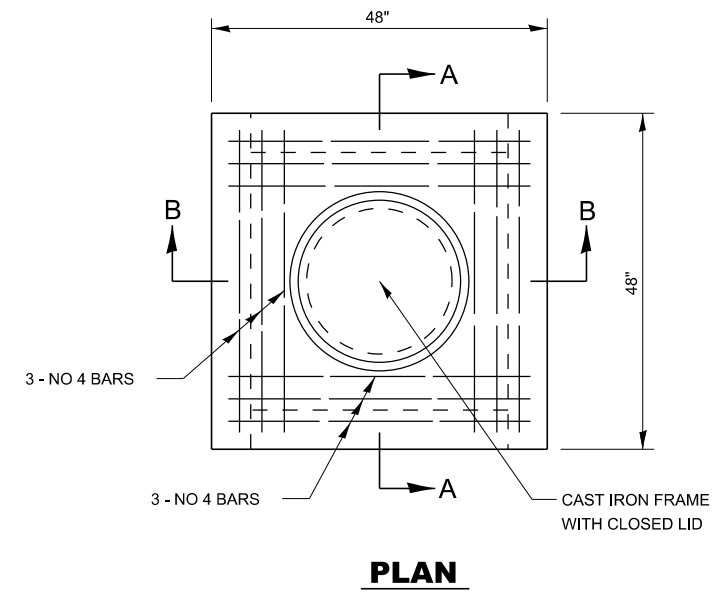

**PLAN**

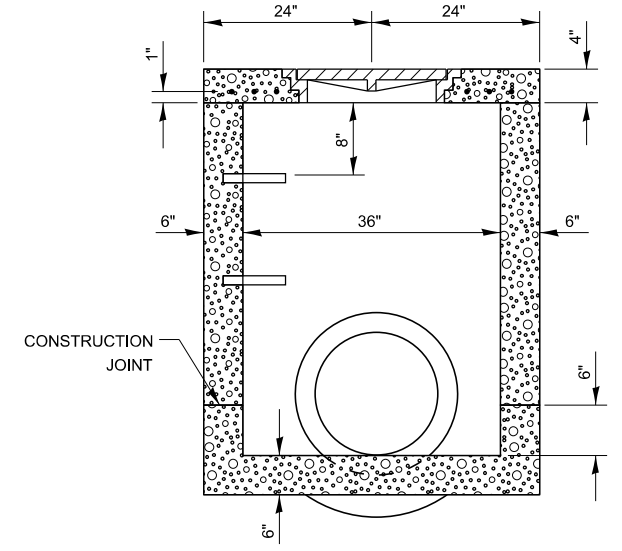

**SECTION A-A**

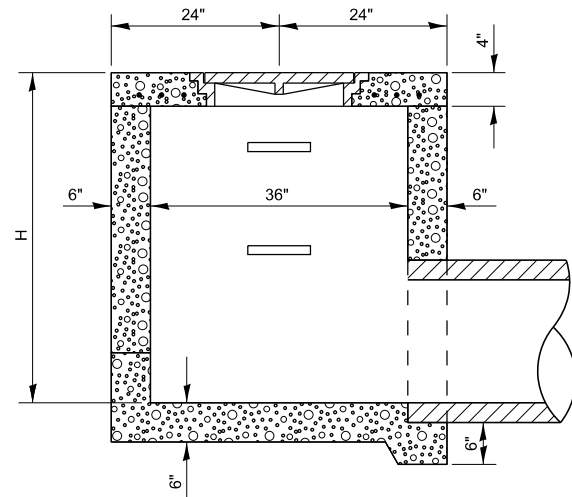

**SECTION B-B**

NOTES:

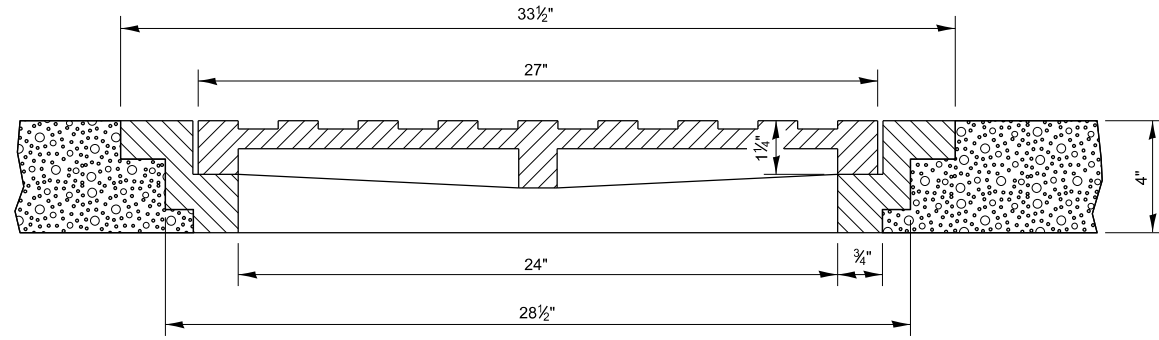

**SECTION THRU FRAME & LID**

WEIGHT OF FRAME & LID, 300 LBS

**MANHOLES, SPECIAL**

602-6

|                              |            |           |
|------------------------------|------------|-----------|
| USER NAME = anthony.grunstad | DESIGNED - | REVISED - |
|                              | DRAWN -    | REVISED - |
| PLOT SCALE = 100,000 ' / in. | CHECKED -  | REVISED - |
| PLOT DATE = 10/3/23          | DATE -     | REVISED - |

**STATE OF ILLINOIS  
DEPARTMENT OF TRANSPORTATION**

|        |       |    |        |      |    |      |
|--------|-------|----|--------|------|----|------|
| SCALE: | SHEET | OF | SHEETS | STA. | TO | STA. |
|--------|-------|----|--------|------|----|------|

|                           |         |        |              |           |
|---------------------------|---------|--------|--------------|-----------|
| F.A. RTE.                 | SECTION | COUNTY | TOTAL SHEETS | SHEET NO. |
|                           |         |        |              |           |
| CONTRACT NO.              |         |        |              |           |
| ILLINOIS FED. AID PROJECT |         |        |              |           |