

GENERAL NOTES

- CONNECTORS - ROUND SIZES THRU 24" ATTACH TO PIPE WITH TYPE #1 STRAPS, ALL OTHER SIZES ATTACH WITH TYPE #2 RODS AND LUGS.
- TOE PLATE EXTENSIONS - WHEN REQUIRED, TOE PLATE EXTENSIONS ARE TO BE THE SAME GAGE AS END SECTIONS. DIMENSIONS SHALL BE OVERALL WIDTH LESS 6 INCHES BY 8 INCHES HIGH.
- OPTIONAL BARS - BARS WHEN SPECIFIED, SHALL BE SCHEDULE 40 GALVANIZED STEEL PIPE.
- TYPICALLY PARALLEL BARS ARE PLACED ON 24" CENTERS.
- TYPICALLY THE CROSS BARS ARE USED ON CROSS DRAIN APPLICATIONS.
- HOLES FOR BAR ATTACHMENTS SHALL BE PROVIDED ON ALL END SECTIONS.
- DIMENSIONS ARE SUBJECT TO MANUFACTURING TOLERANCES.
- THESE END SECTIONS WILL BE PAID FOR AT THE CONTRACT UNIT PRICE PER EACH FOR SLOPED METAL END SECTIONS WITH GRATE OF THE DIAMETER SPECIFIED, WHICH SHALL INCLUDE FURNISHING AND INSTALLING THE END SECTION COMPLETE IN PLACE, INCLUDING THE TOE PLATE, EXCAVATING, BACKFILLING, CONNECTING TO THE PIPE, AND CROSS DRAINAGE BARS.

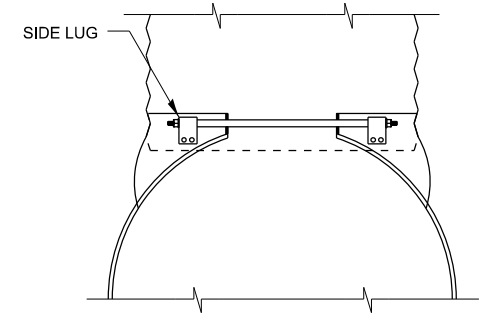

TYPE #1 CONNECTOR DETAILS THRU 24" GALVANIZED STRAP

TYPE #2 CONNECTOR DETAILS (SHOWN) FOR 30" AND LARGER 21" x 15" AND LARGER 1/2" THREADED ROD W/FLANGED NUT AND SIDE LUG

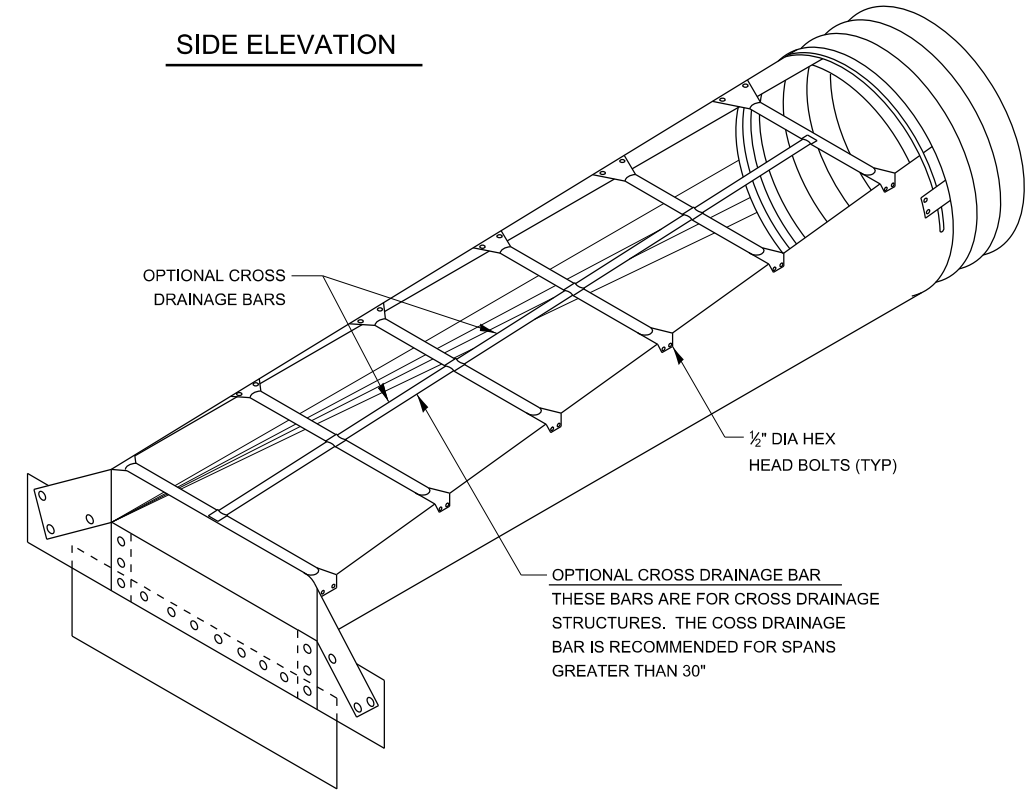

METAL END SECTIONS FOR ROUND PIPE										
PIPE DIA (IN)	MIN THICK IN	GAGE	DIMENSIONS (INCHES)			L DIMENSIONS				
			A	H	W	OVERALL WIDTH	SLOPE	LENGTH (IN)	SLOPE	LENGTH (IN)
15	.064	16	8	6	21	37	6:1	30	4:1	20
18	.064	16	8	6	24	40	6:1	48	4:1	32
21	.064	16	8	6	27	43	6:1	66	4:1	44
24	.064	16	8	6	30	46	6:1	84	4:1	56
30	.109	12	12	9	36	60	6:1	120	4:1	80
36	.109	12	12	9	42	66	4:1	104	6:1	156
42	.109	12	16	12	48	80	4:1	128	6:1	192
48	.109	12	16	12	54	86	4:1	152	6:1	228
54	.109	12	16	12	60	92	4:1	176	6:1	264
60	.109	12	16	12	66	98	4:1	200	6:1	300

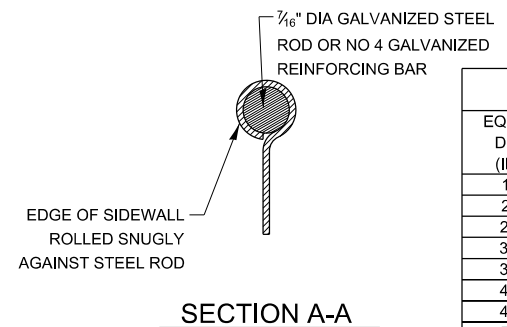
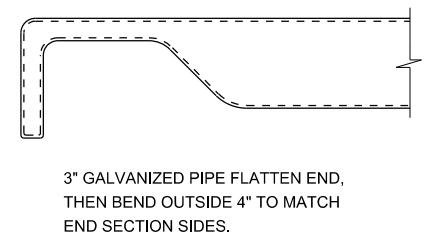
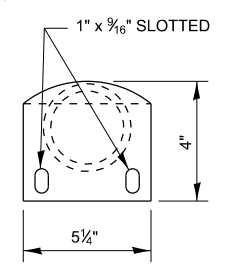
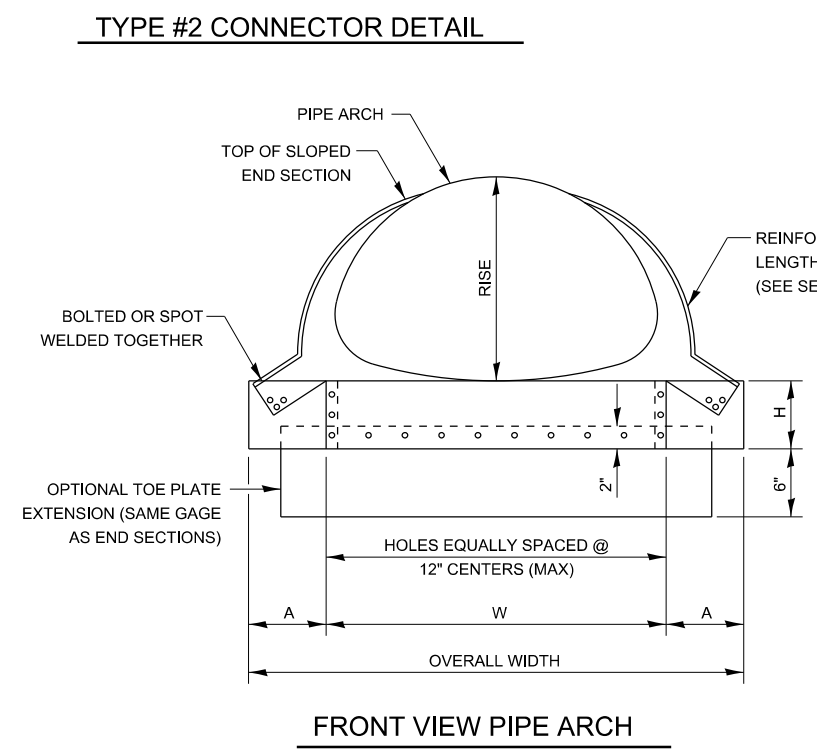

METAL END SECTIONS FOR PIPE ARCH												
EQUIV DIA (IN)	(INCHES)		MIN THICK IN	GAGE	DIMENSIONS (INCHES)			OVERALL WIDTH	L DIMENSIONS			
	SPAN	RISE			A	H	W		SLOPE	LENGTH (IN)	SLOPE	LENGTH (IN)
18	21	15	.064	16	8	6	27	43	6:1	30	4:1	20
21	24	18	.064	16	8	6	30	46	6:1	48	4:1	32
24	28	20	.064	16	8	6	34	50	6:1	60	4:1	40
30	36	24	.079	14	12	9	41	65	6:1	84	4:1	56
36	42	29	.109	12	12	9	48	72	6:1	114	4:1	76
42	49	33	.109	12	16	12	55	87	4:1	92	6:1	138
48	57	38	.109	12	16	12	63	95	4:1	112	6:1	168
54	64	43	.109	12	16	12	70	102	4:1	132	6:1	198
60	71	47	.109	12	16	12	77	109	4:1	148	6:1	222
72	83	57	.109	12	16	12	89	121	4:1	188	6:1	282

MODEL: det 3 details
FILE: \\msc\pwworkspace\benetec\com\PIV\DOT\Documents\DOT Offices\District 3\Standards - District 3\DETAILS\SUBDISTRICT 3 STANDARD DETAILS - DGN\500-599 STRUCTURES.dgn

USER NAME = ronald.pohar	DESIGNED -	REVISED -
DRAWN -	REVISOR -	
PLOT SCALE = 100,000 ' / in.	CHECKED -	REVISOR -
PLOT DATE = 3/18/2024	DATE -	REVISOR -

**STATE OF ILLINOIS
DEPARTMENT OF TRANSPORTATION**

SLOPED METAL END SECTIONS WITH GRATE

SCALE: SHEET OF SHEETS STA. TO STA.

F.A. RTE.	SECTION	COUNTY	TOTAL SHEETS	SHEET NO.
CONTRACT NO.				
ILLINOIS FED. AID PROJECT				