

HANDRAIL FOR CONCRETE STEPS

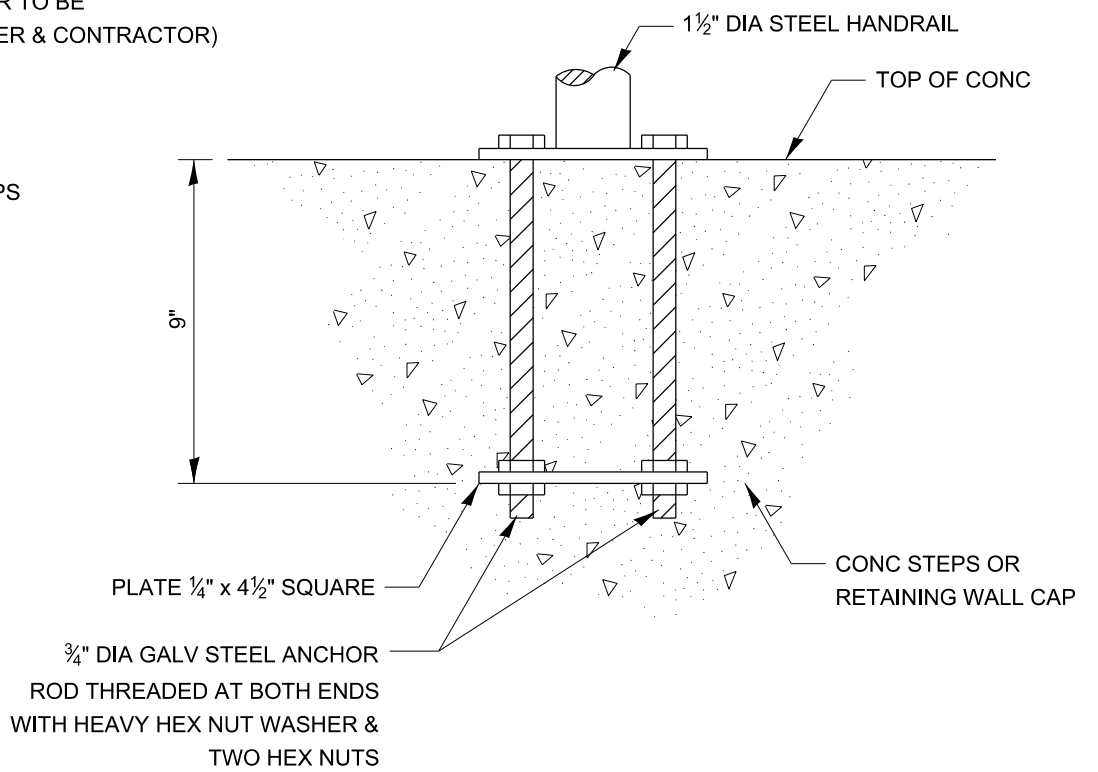

ANCHOR ROD DETAIL

(INCLUDED IN THE COST OF HAND OR SAFETY RAIL)

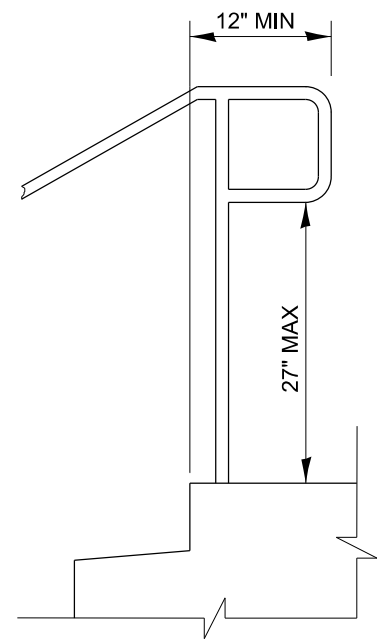
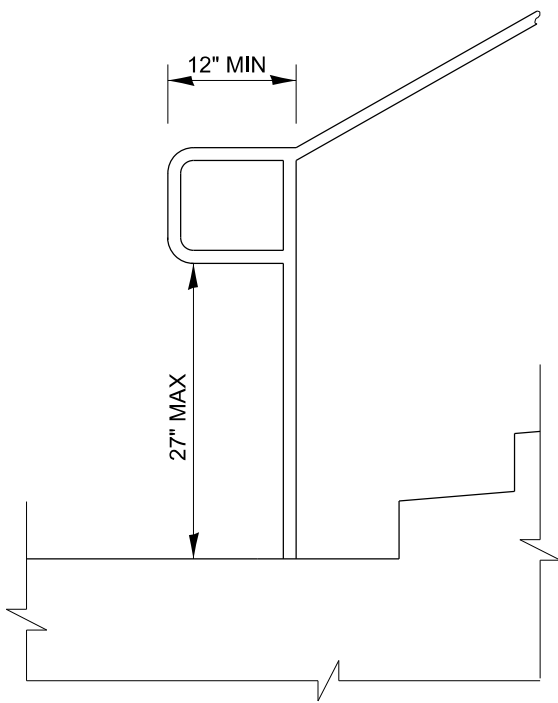

EXTENSION AT TOP OF RUN DETAIL

NOTES:

STAIRWAYS SHALL HAVE CONTINUOUS HANDRAILS BOTH SIDES OF ALL STAIRS.

THE INSIDE HANDRAIL ON SWITCHBACK OR DOGLEG STAIRS SHALL ALWAYS BE CONTINUOUS.

GRIPPING SURFACES SHALL BE UNINTERRUPTED BY NEWEL POSTS, OTHER CONSTRUCTION ELEMENTS, OR OBSTRUCTIONS.

ENDS OF HANDRAIL SHALL BE EITHER ROUNDED OR RETURNED SMOOTHLY TO FLOOR, WALL, OR POST.

HAND & SAFETY RAILS SHALL NOT ROTATE WITHIN THEIR FITTINGS.

THE CLEAR SPACES BETWEEN HANDRAILS AND ANY WALL SHALL BE 1 1/2".

HANDRAIL SHALL CONFORM TO SECTION 509 WITH THE EXCEPTION THAT ALL PIPE AND CONNECTIONS SHALL BE WELDED GALVANIZED OR ALUMINUM ACCORDING TO ARTICLE 1006.27, 1006.30, OR 1006.34.

THE DIAMETER OF THE GRIPPING SURFACE OF THE HANDRAIL SHALL BE 1 1/4" TO 1 1/2".

THIS WORK SHALL BE PAID FOR AT THE CONTRACT UNIT PRICE PER FOOT FOR PIPE HANDRAIL.

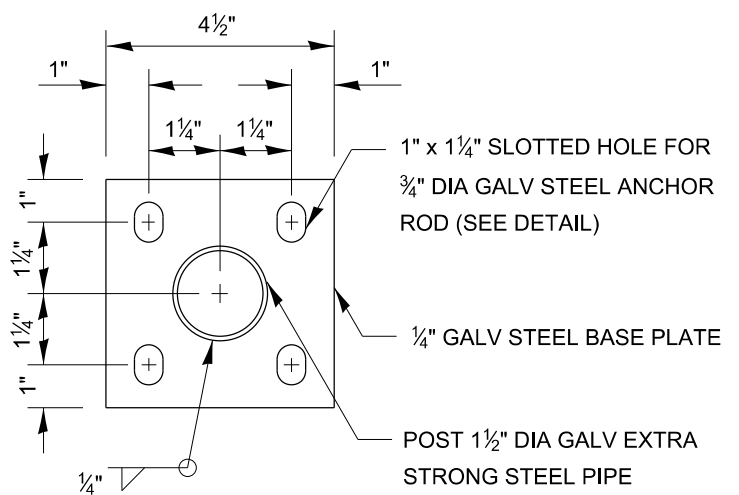

POST CASE PLATE DETAIL

(INCLUDED IN THE COST OF HAND OR SAFETY RAIL)

PIPE HANDRAILS FOR STEPS