

TYPICAL NON-COMMERCIAL P.C.C. ENTRANCE DETAIL - URBAN

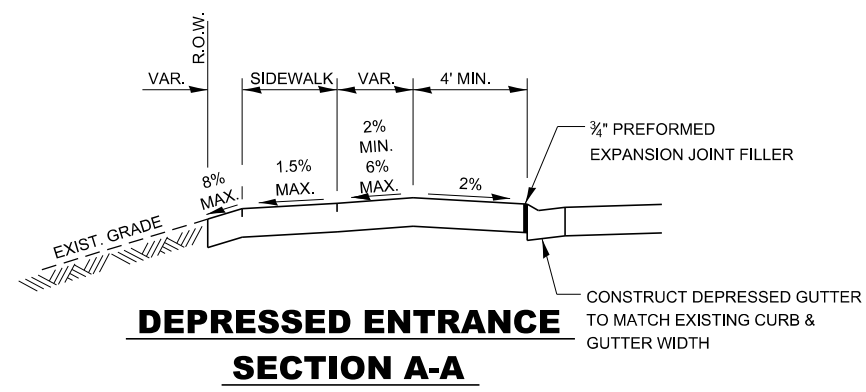

DEPRESSED ENTRANCE SECTION A-A

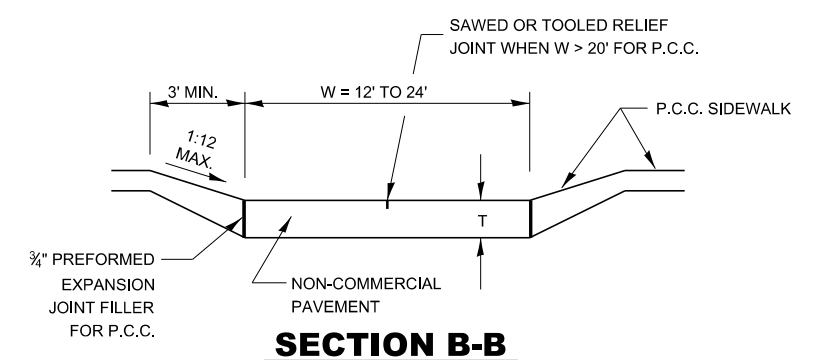

SECTION B-B

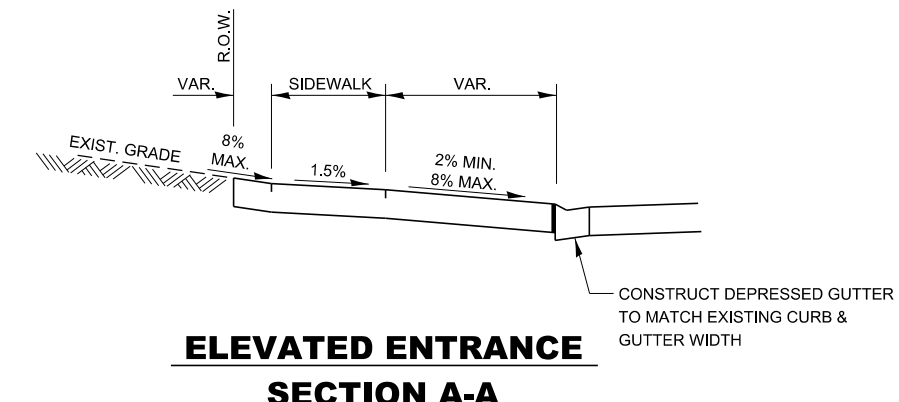

ELEVATED ENTRANCE SECTION A-A

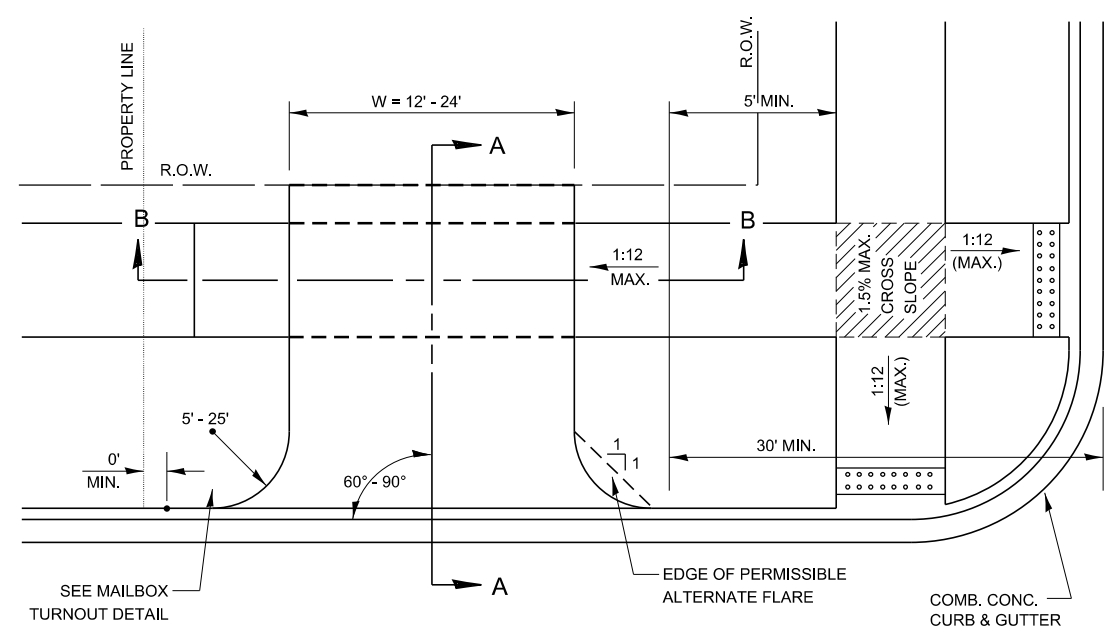

TYPICAL NON-COMMERCIAL HMA ENTRANCE DETAIL - URBAN

- NOTES:
- X = 7' (NON-COMMERCIAL) (MINIMUM)
 - INCLUDE EXPANSION JOINTS AND RELIEF JOINTS IN P.C.C. DRIVEWAY PAVEMENT TO CONTROL CRACKING. COST INCLUDED IN COST OF ENTRANCE PAVEMENT.
 - AS THE DIMENSION "D" APPROACHES A MINIMUM OF 2', THE TRANSITION TO DEPRESSED CURB SHALL BE NO STEEPER THAN 1V:12H.

- DESIGNER NOTES:
- INSTALL MAILBOX TURNOUT PER DETAIL 406-14 IF DELIVERY IS ON-ROAD BY POST MASTER.

MODEL det 3 dets1b
FILE: \\pawbentley.com\PI\DOT\Documents\DOT Office\District 3\Standards - District 3\DETAILS\DISTRICT 3 STANDARD DETAILS.DGN\400-499_SURE_CSE_PAVT_REHAB & SHLD.dgn

USER NAME = ronald.pohar	DESIGNED -	REVISED -	STATE OF ILLINOIS DEPARTMENT OF TRANSPORTATION	F.A. RTE.	SECTION	COUNTY	TOTAL SHEETS	SHEET NO.	
PLOT SCALE = 100,000' / in.	DRAWN -	REVISED -		SCALE:	SHEET	OF	SHEETS	STA.	TO STA.
PLOT DATE = 3/15/2024	CHECKED -	REVISED -		CONTRACT NO.					
	DATE -	REVISED -		ILLINOIS FED. AID PROJECT					