

F.A.I. RTE.	SECTION	COUNTY	TOTAL SHEETS	SHEET NO.
80/394	*	COOK	870	801
STA.		TO STA.		
FED. ROAD DIST. NO. 1		ILLINOIS FED. AID PROJECT		

25 20 15 10 5 0 5 10 15 20 25

FINAL SURVEY NOTE BOOK NO.	DATE

ORIGINAL SURVEY NOTE BOOK NO.	DATE

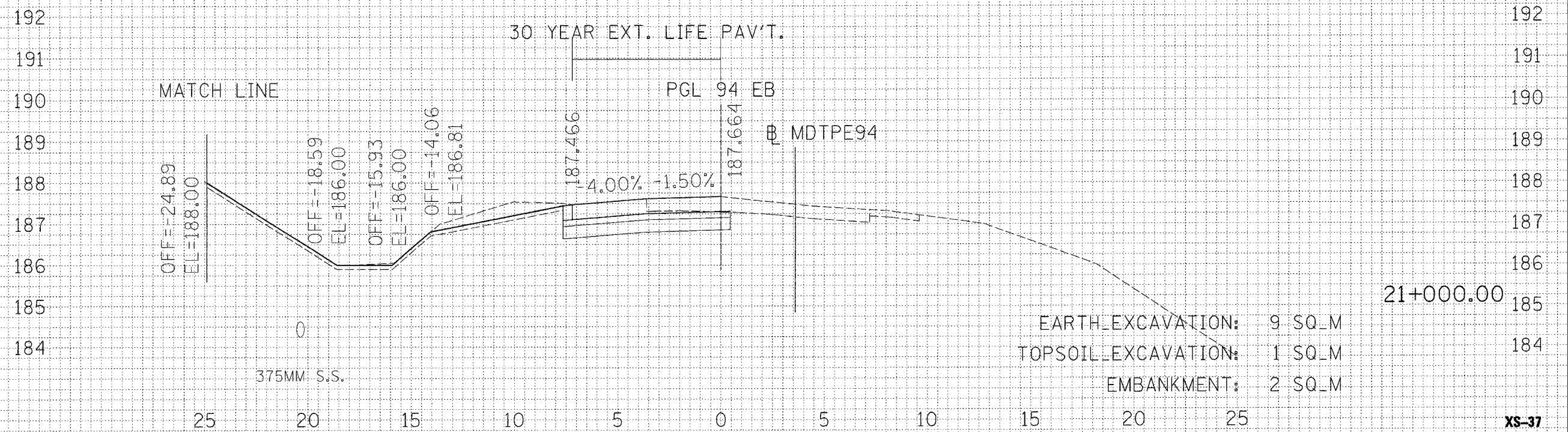

REVISIONS		ILLINOIS DEPARTMENT OF TRANSPORTATION F.A.I. ROUTE 80/94 (INTERSTATE 80/294)
NAME	DATE	
		CROSS SECTIONS EB I-94  HORIZ. SCALE: 1:100 VERT. SCALE: 1:50 DATE: JULY 18, 2005  DRAWN BY: TRK CHECKED BY: RCH

**McDonough Associates Inc.**  
Engineers / Architects

XS-37

F.A.I. RTE.	SECTION	COUNTY	TOTAL SHEETS	SHEET NO.
80/394	*	COOK	870	802
STA.		TO STA.		
FED. ROAD DIST. NO. 1		ILLINOIS FED. AID PROJECT		

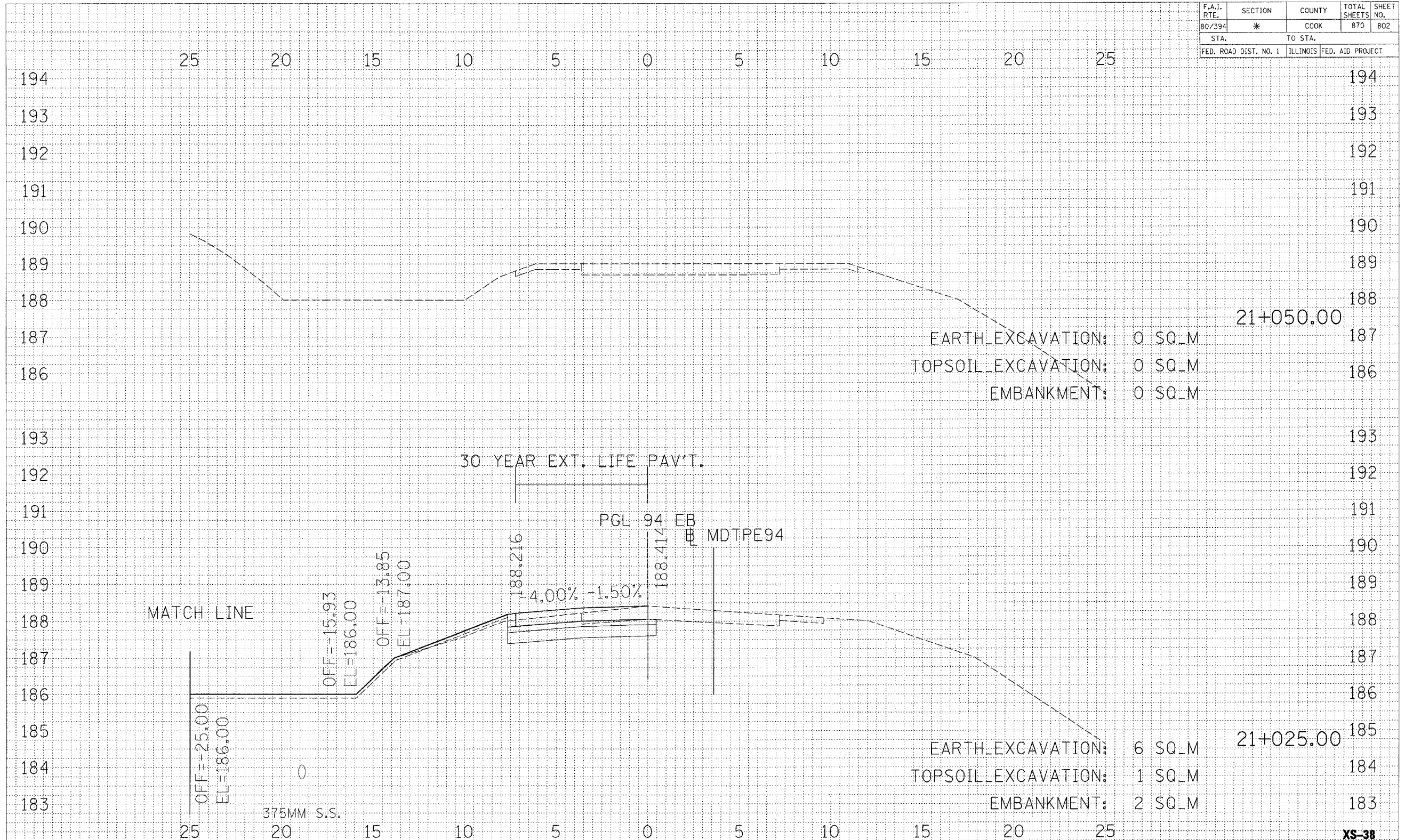

FINAL SURVEY	DATE
BY	
REVISIONS	
PLOTTED	
TEMPLATE	
NOTE BOOK	
AREAS CHECKED	
NO.	

ORIGINAL SURVEY	DATE
BY	
REVISIONS	
PLOTTED	
TEMPLATE	
NOTE BOOK	
AREAS CHECKED	
NO.	

REVISIONS		ILLINOIS DEPARTMENT OF TRANSPORTATION F.A.I. ROUTE 80/94 (INTERSTATE 80/294)
NAME	DATE	
		CROSS SECTIONS EB I-94  HORIZ. SCALE: 1:100 VERT. SCALE: 1:50 DATE: JULY 18, 2005 DRAWN BY: TRK CHECKED BY: RCH



F.A.I. RTE.	SECTION	COUNTY	TOTAL SHEETS	SHEET NO.
80/294	*	COOK	870	803
STA.		TO STA.		
FED. ROAD DIST. NO. 1		ILLINOIS FED. AID PROJECT		

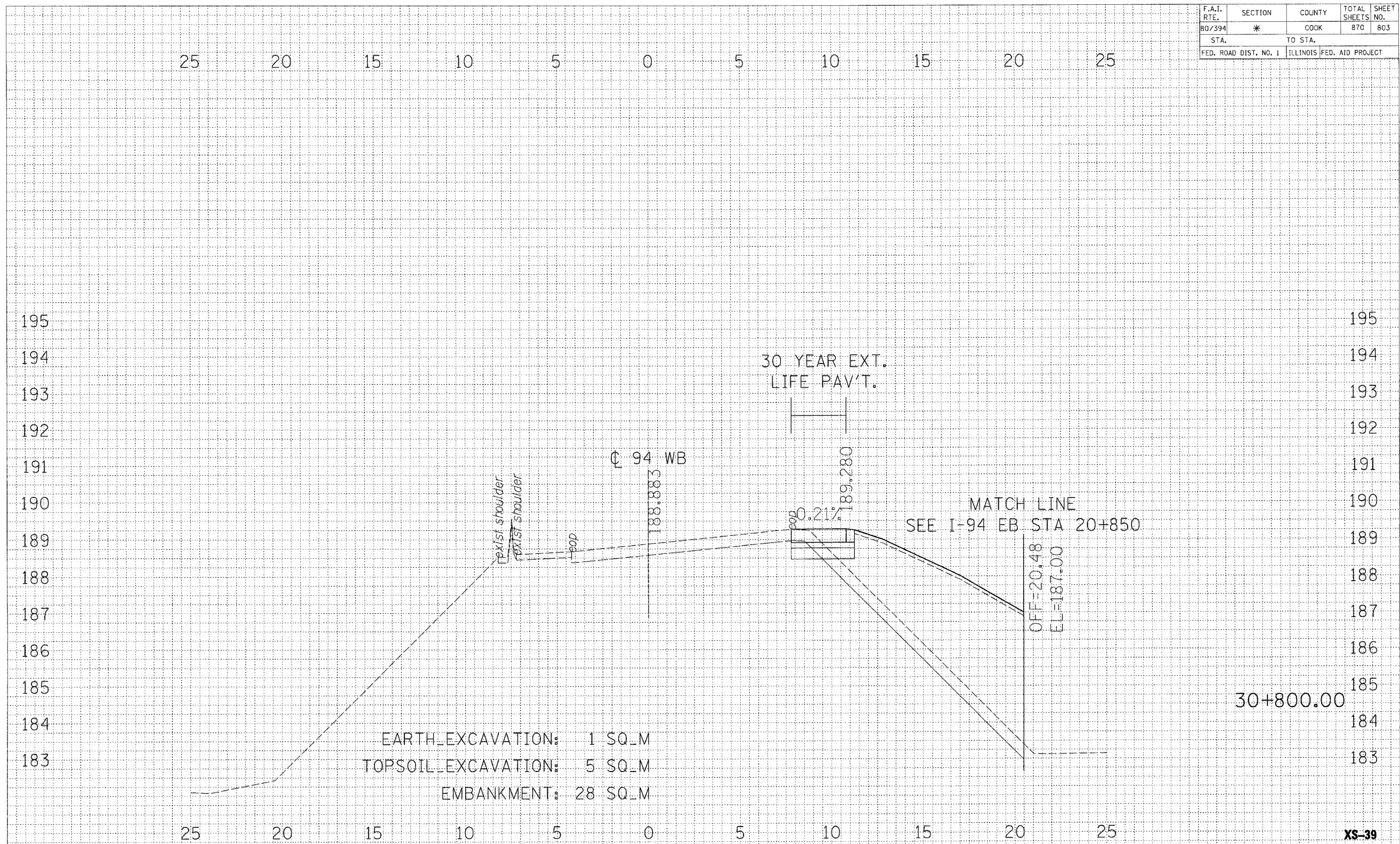

FINAL SURVEY	BY	DATE
SURVEYED		
NOTE BOOK		
AREAS CHECKED		
NO.		

ORIGINAL SURVEY	BY	DATE
SURVEYED		
NOTE BOOK		
AREAS CHECKED		
NO.		

REVISIONS		ILLINOIS DEPARTMENT OF TRANSPORTATION F.A.I. ROUTE 80/94 (INTERSTATE 80/294)
NAME	DATE	
		<b>CROSS SECTIONS</b> <b>WB I-94</b> HORIZ. SCALE: 1:100 VERT. SCALE: 1:50 DATE: JULY 18, 2005 DRAWN BY: TRK CHECKED BY: RCH <b>McDonough Associates Inc.</b> Engineers / Architects

XS-39

F.A.I. RTE.	SECTION	COUNTY	TOTAL SHEETS	SHEET NO.
80/394	*	COOK	870	804
STA.		TO STA.		
FED. ROAD DIST. NO. 1		ILLINOIS FED. AID PROJECT		

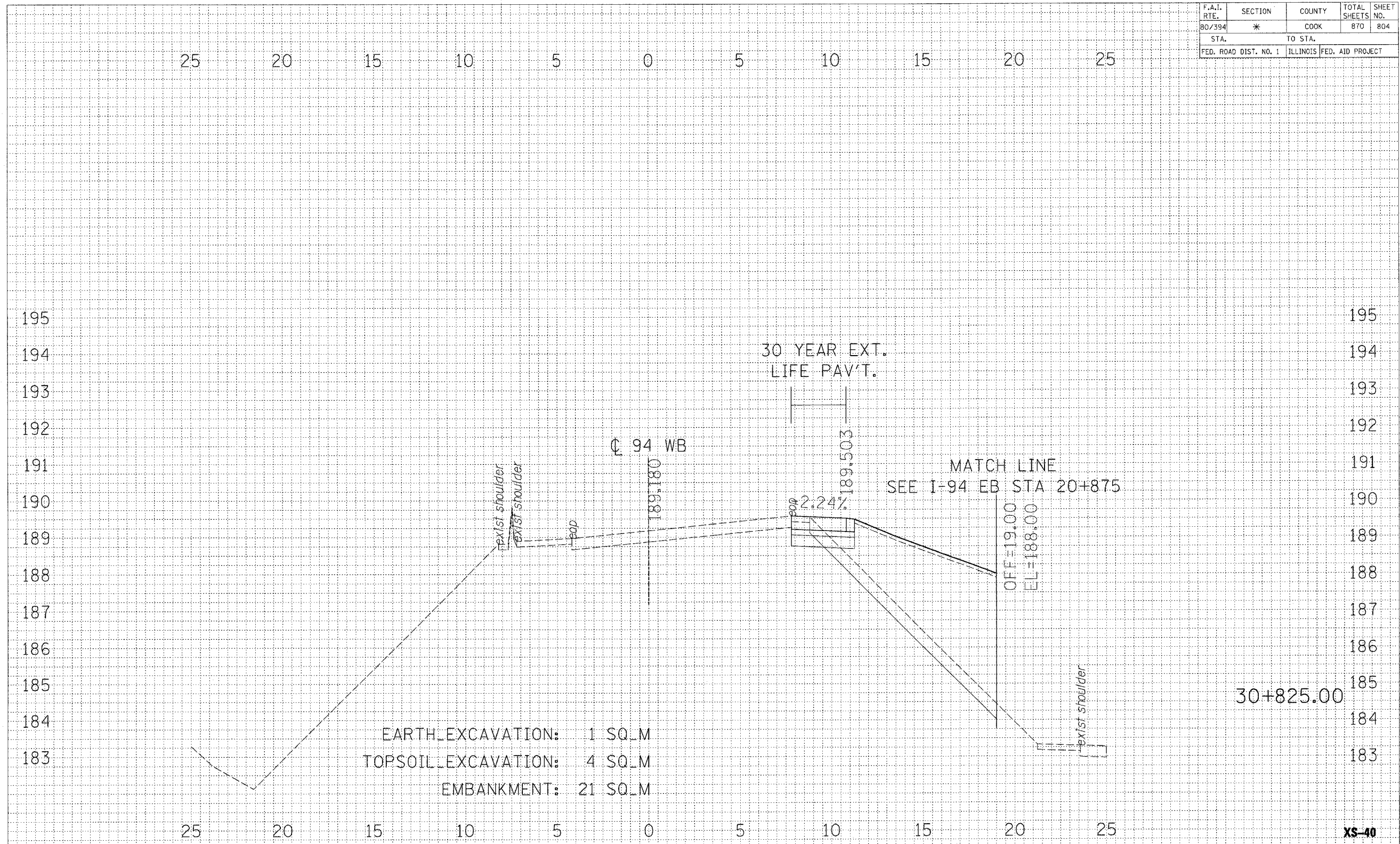

EARTH EXCAVATION: 1 SQ\_M  
 TOPSOIL EXCAVATION: 4 SQ\_M  
 EMBANKMENT: 21 SQ\_M

FINAL SURVEY	BY	DATE
SURVEYED		
NOTE BOOK		
AREAS CHECKED		
NO.		

ORIGINAL SURVEY	BY	DATE
SURVEYED		
NOTE BOOK		
AREAS CHECKED		
NO.		

REVISIONS		ILLINOIS DEPARTMENT OF TRANSPORTATION F.A.I. ROUTE 80/94 (INTERSTATE 80/294)
NAME	DATE	
		CROSS SECTIONS WB I-94
		HORIZ. SCALE: 1:100 VERT. SCALE: 1:50 DATE: JULY 18, 2005
		DRAWN BY: TRK CHECKED BY: RCH
		<b>McDonough Associates Inc.</b> Engineers / Architects

F.A.I. RTE.	SECTION	COUNTY	TOTAL SHEETS	SHEET NO.
80/394	*	COOK	870	805
STA.		TO STA.		
FED. ROAD DIST. NO. 1		ILLINOIS FED. AID PROJECT		

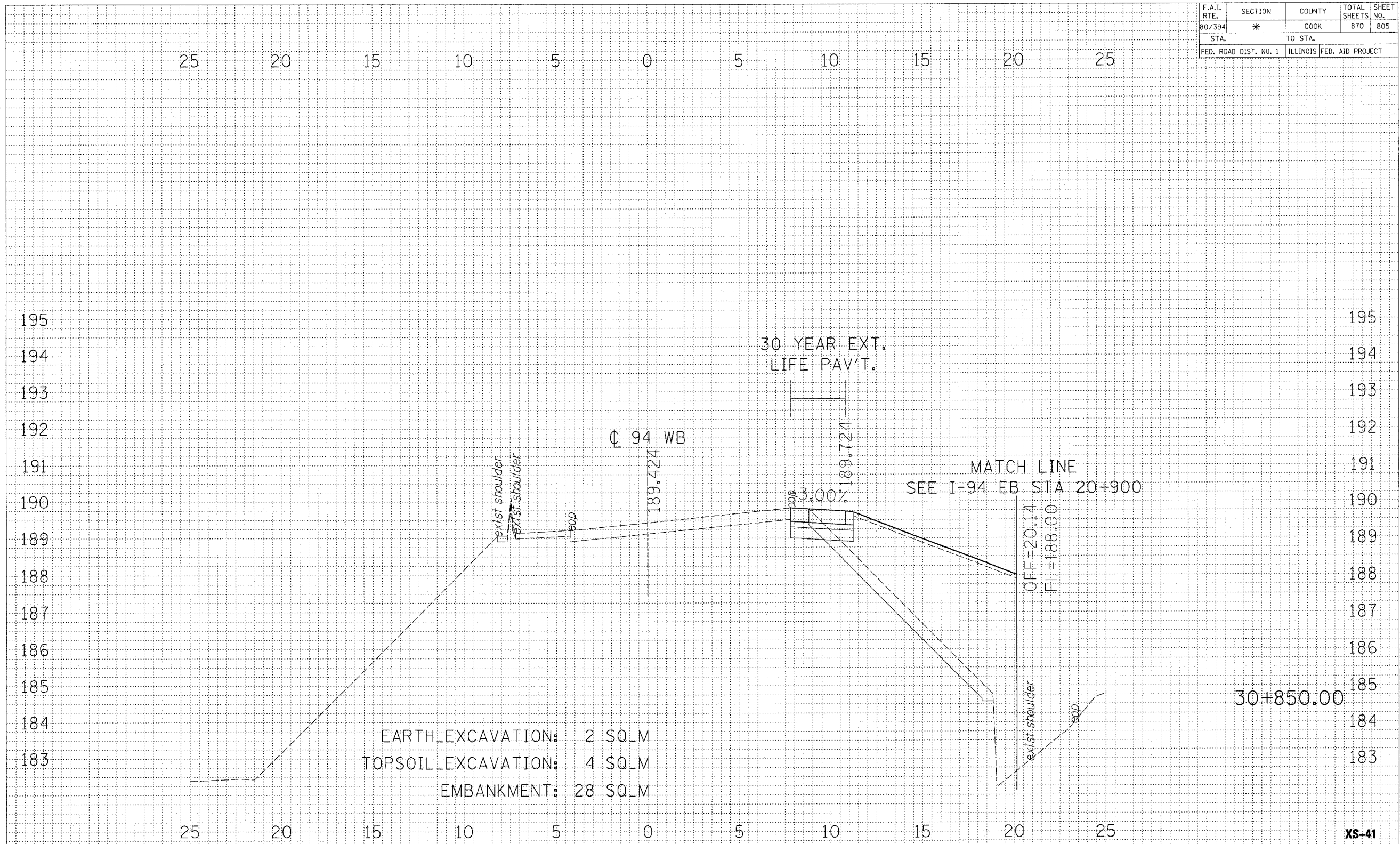

REVISIONS	DATE
BY	
DATE	
BY	
DATE	
BY	
DATE	

REVISIONS	DATE
BY	
DATE	
BY	
DATE	
BY	
DATE	

REVISIONS	
NAME	DATE

ILLINOIS DEPARTMENT OF TRANSPORTATION  
 F.A.I. ROUTE 80/94 (INTERSTATE 80/294)

**CROSS SECTIONS  
 WB I-94**

HORIZ. SCALE: 1:100  
 VERT. SCALE: 1:50  
 DATE: JULY 18, 2005

DRAWN BY: TRK  
 CHECKED BY: RCH

**McDonough Associates Inc.**  
 Engineers / Architects

XS-41



F.A.I. RTE.	SECTION	COUNTY	TOTAL SHEETS NO.	SHEET NO.
80/394	*	COOK	870	806
STA.		TO STA.		
FED. ROAD DIST. NO. 1		ILLINOIS FED. AID PROJECT		

25 20 15 10 5 0 5 10 15 20 25

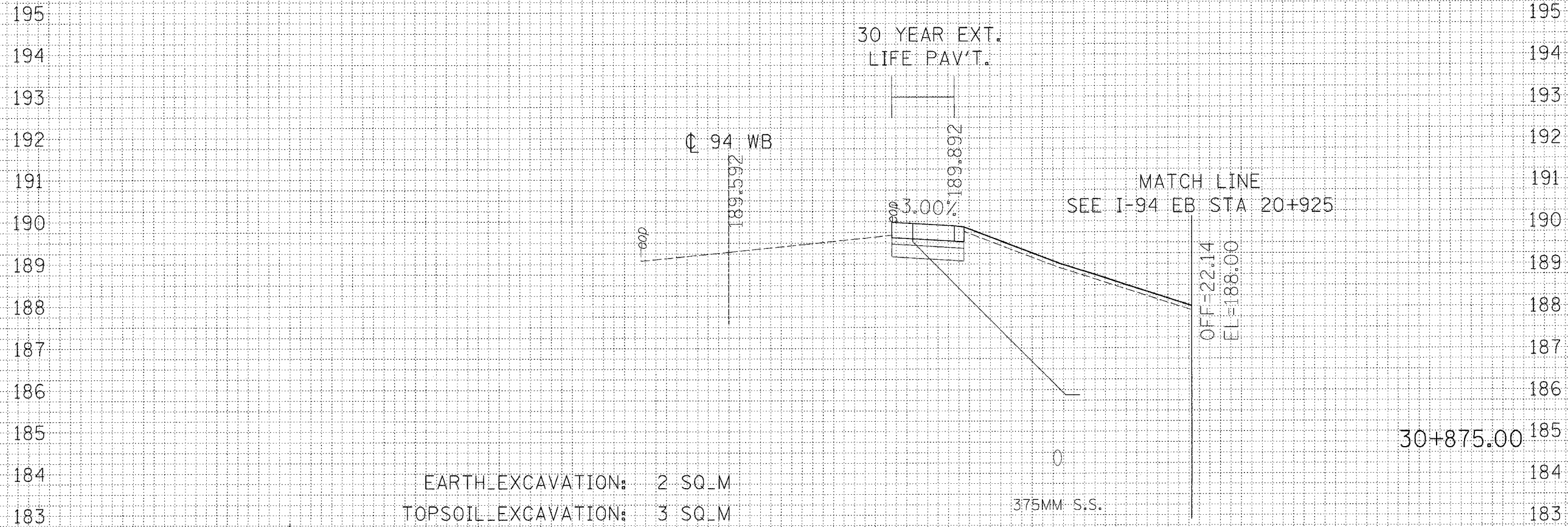

EARTH\_EXCAVATION: 2 SQ\_M  
 TOPSOIL\_EXCAVATION: 3 SQ\_M  
 EMBANKMENT: 42 SQ\_M

30+875.00

XS-42

FINAL SURVEY NOTE BOOK NO.	BY	DATE
REVISED PLOTTING TEMPLATE AREAS CHECKED		

ORIGINAL SURVEY NOTE BOOK NO.	BY	DATE
REVISED PLOTTING TEMPLATE AREAS CHECKED		

REVISIONS	
NAME	DATE

ILLINOIS DEPARTMENT OF TRANSPORTATION  
 F.A.I. ROUTE 80/94 (INTERSTATE 80/294)

CROSS SECTIONS  
 WB I-94

HORIZ. SCALE: 1:100  
 VERT. SCALE: 1:50  
 DATE: JULY 18, 2005

DRAWN BY: TRK  
 CHECKED BY: RCH

**McDonough Associates Inc.**  
 Engineers / Architects



F.A.I. RTE.	SECTION	COUNTY	TOTAL SHEETS	SHEET NO.
80/394	*	COOK	870	808
STA.		TO STA.		
FED. ROAD DIST. NO. 1		ILLINOIS FED. AID PROJECT		

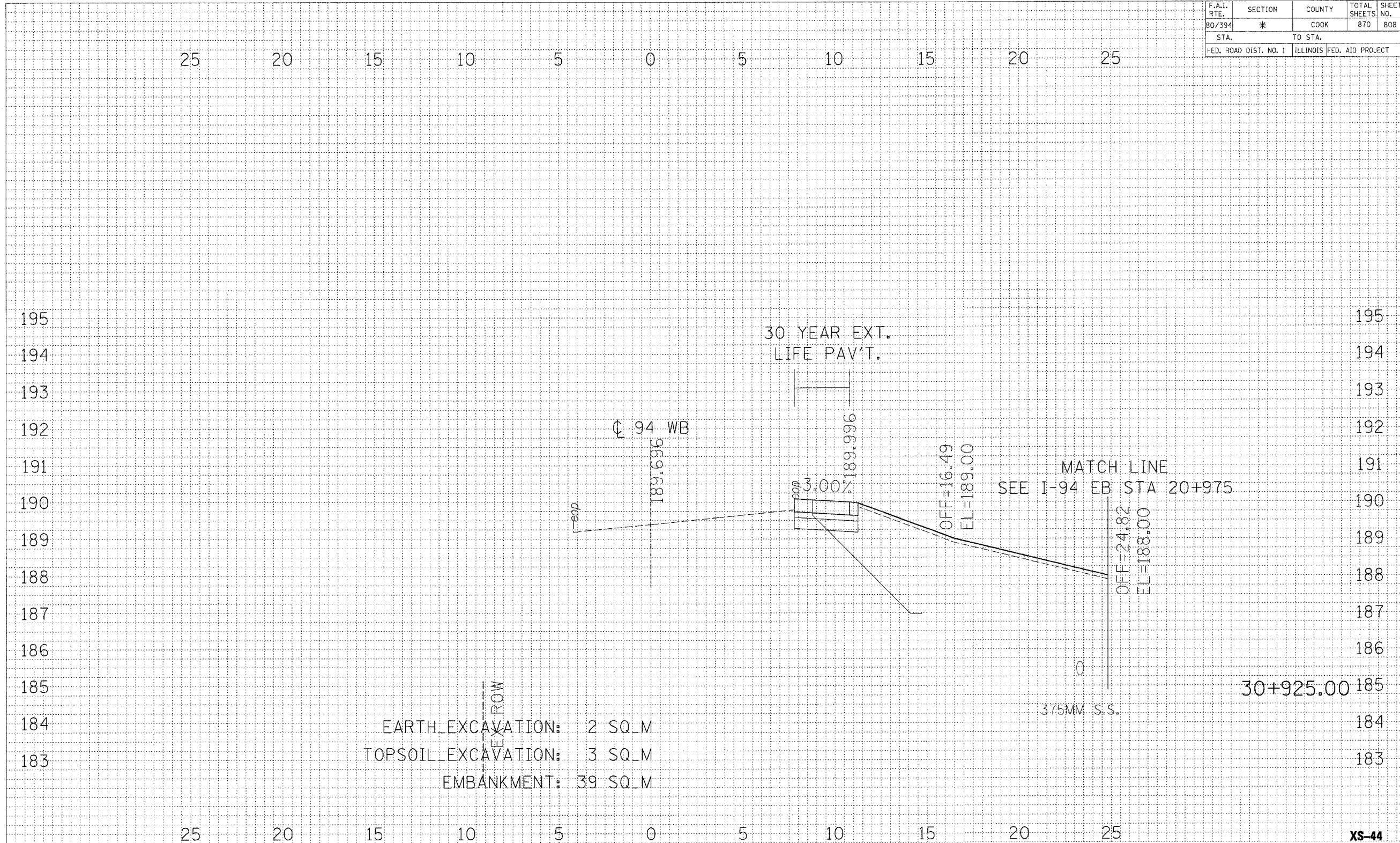

FINAL SURVEY NOTE BOOK NO.	BY	DATE

ORIGINAL SURVEY NOTE BOOK NO.	BY	DATE

REVISIONS		ILLINOIS DEPARTMENT OF TRANSPORTATION F.A.I. ROUTE 80/94 (INTERSTATE 80/294)
NAME	DATE	
		<b>CROSS SECTIONS</b> <b>WB I-94</b>  HORIZ. SCALE: 1:100 VERT. SCALE: 1:50 DATE: JULY 18, 2005 DRAWN BY: TRK CHECKED BY: RCH McDonough Associates Inc. Engineers / Architects



F.A.I. R.T.E.	SECTION	COUNTY	TOTAL SHEETS	SHEET NO.
80/394	*	COOK	870	809
STA.		TO STA.		
FED. ROAD DIST. NO. 1		ILLINOIS FED. AID PROJECT		

25 20 15 10 5 0 5 10 15 20 25

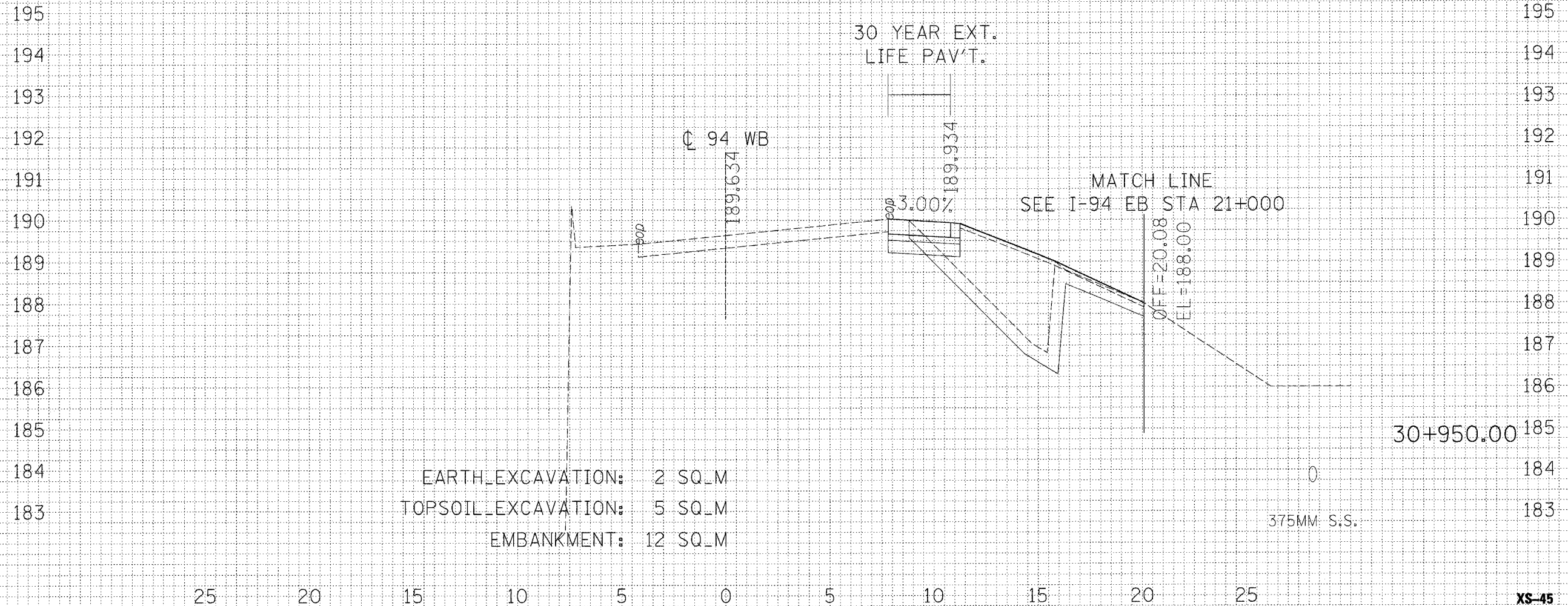

FINAL SURVEY NOTE BOOK NO.	BY	DATE
REVISIONS		

ORIGINAL SURVEY NOTE BOOK NO.	BY	DATE
REVISIONS		

REVISIONS		ILLINOIS DEPARTMENT OF TRANSPORTATION F.A.I. ROUTE 80/94 (INTERSTATE 80/294)
NAME	DATE	
		CROSS SECTIONS WB I-94
HORIZ. SCALE: 1:100		DRAWN BY: TRK CHECKED BY: RCH
VERT. SCALE: 1:50		
DATE: JULY 18, 2005		McDonough Associates Inc. Engineers / Architects

F.A.I. RTE.	SECTION	COUNTY	TOTAL SHEETS	SHEET NO.
80/394	*	COOK	870	810
STA.		TO STA.		
FED. ROAD DIST. NO. 1		ILLINOIS FED. AID PROJECT		

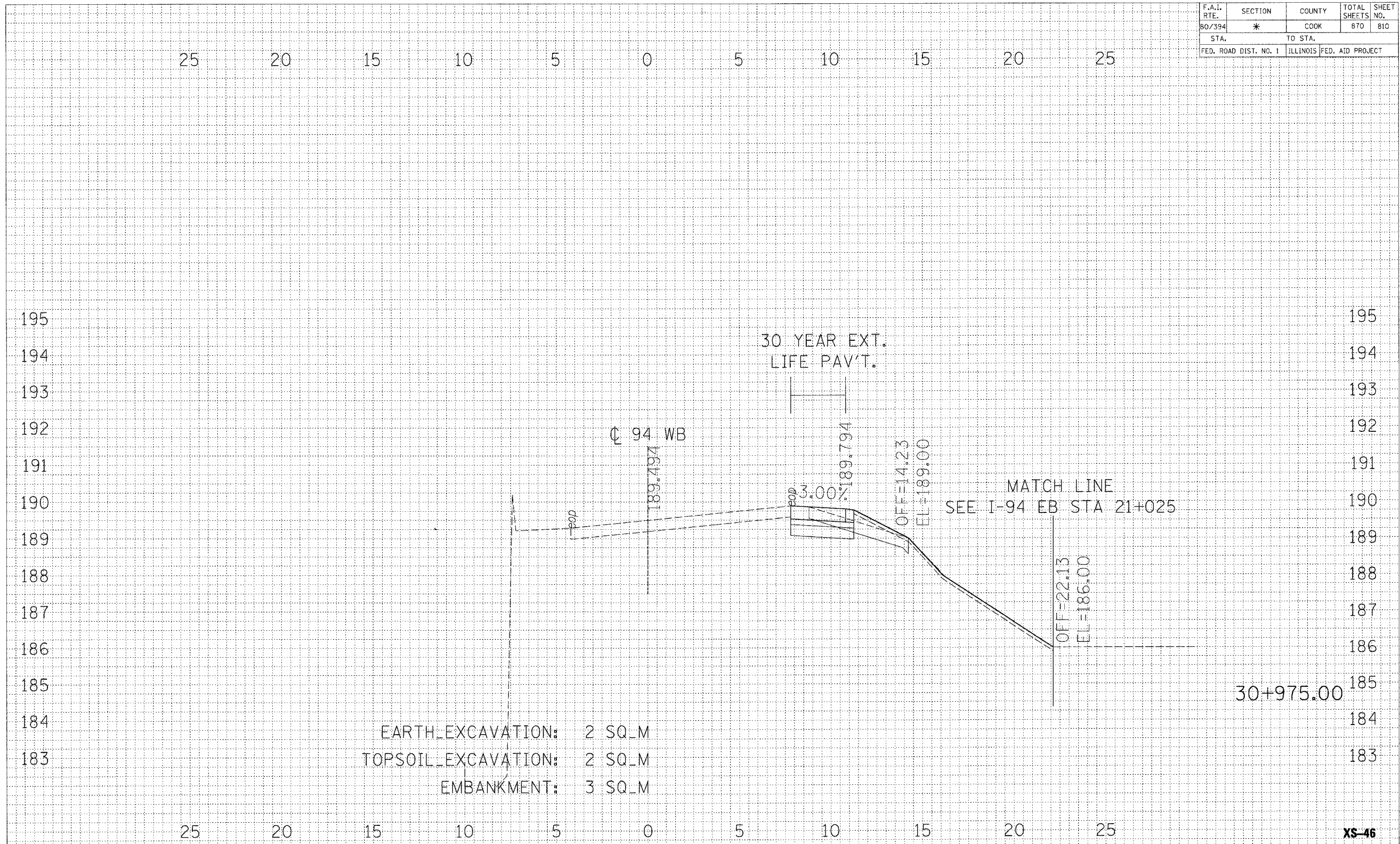

FINAL SURVEY	BY	DATE
REVISIONS		
NOTE BOOK		
AREAS CHECKED		
NO.		

ORIGINAL SURVEY	BY	DATE
REVISIONS		
NOTE BOOK		
AREAS CHECKED		
NO.		

REVISIONS		ILLINOIS DEPARTMENT OF TRANSPORTATION F.A.I. ROUTE 80/94 (INTERSTATE 80/294)
NAME	DATE	
		CROSS SECTIONS WB I-94  HORIZ. SCALE: 1:100 VERT. SCALE: 1:50 DATE: JULY 18, 2005  DRAWN BY: TRK CHECKED BY: RCH  McDonough Associates Inc. Engineers / Architects

F.A.I. RTE.	SECTION	COUNTY	TOTAL SHEETS	SHEET NO.
80/294	*	COOK	870	811
STA.		TO STA.		
FED. ROAD DIST. NO. 1		ILLINOIS FED. AID PROJECT		

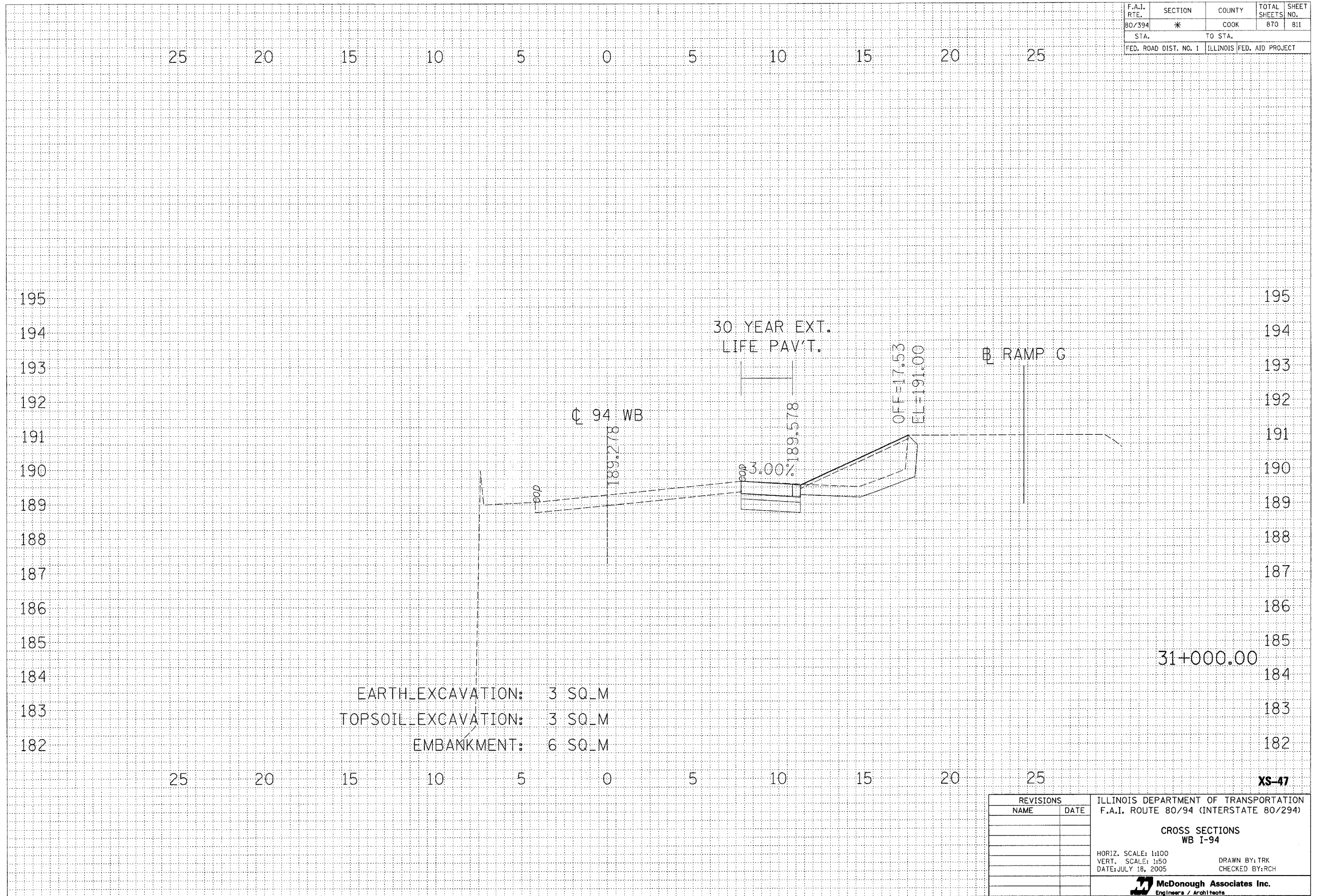

EARTH EXCAVATION: 3 SQ\_M  
 TOPSOIL EXCAVATION: 3 SQ\_M  
 EMBANKMENT: 6 SQ\_M

31+000.00

FINAL SURVEY	DATE
BY	
SIGNED SURVEY	
NOTE BOOK	
AREAS	
CHECKED	

ORIGINAL SURVEY	DATE
BY	
SIGNED SURVEY	
NOTE BOOK	
AREAS	
CHECKED	

REVISIONS		ILLINOIS DEPARTMENT OF TRANSPORTATION F.A.I. ROUTE 80/94 (INTERSTATE 80/294)
NAME	DATE	
		CROSS SECTIONS WB I-94  HORIZ. SCALE: 1:100 VERT. SCALE: 1:50 DATE: JULY 18, 2005  DRAWN BY: TRK CHECKED BY: RCH  McDonough Associates Inc. Engineers / Architects



• (0203.1 & 0312-708W) R-3 CONTRACT • 62108			
F.A.I. RTE.	SECTION	COUNTY	TOTAL SHEETS NO.
80/94	•	COOK	870 812
STA.	TO STA.		
FED ROAD DIST.	ILLINOIS FED. AID PROJECT		

FINAL SURVEY	DATE
BY	
REVISIONS	
PLOTTED	
TEMPLATE	
NOTE BOOK	
AREAS CHECKED	

ORIGINAL SURVEY	DATE
BY	
REVISIONS	
PLOTTED	
TEMPLATE	
NOTE BOOK	
AREAS CHECKED	

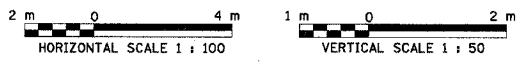
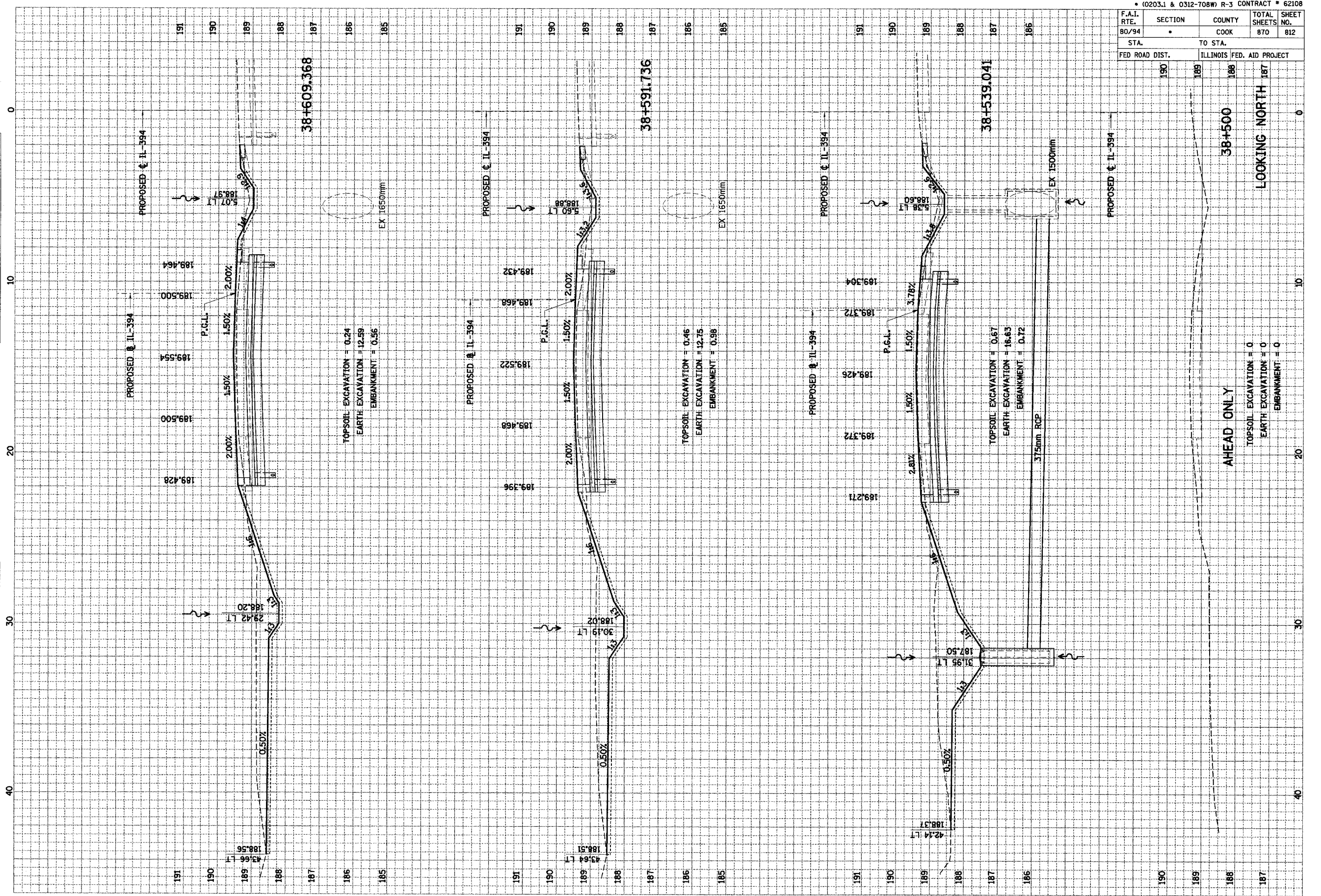

F.A.I. RTE.	SECTION	COUNTY	TOTAL SHEETS	SHEET NO.
80/94	*	COOK	870	813
STA. TO STA.		ILLINOIS FED. AID PROJECT		
FED ROAD DIST.				

FINAL SURVEYED SURVEY TEMPLATE AREAS CHECKED	BY	DATE
NO.		

ORIGINAL SURVEYED SURVEY TEMPLATE AREAS CHECKED	BY	DATE
NO.		

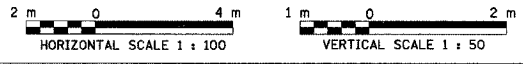
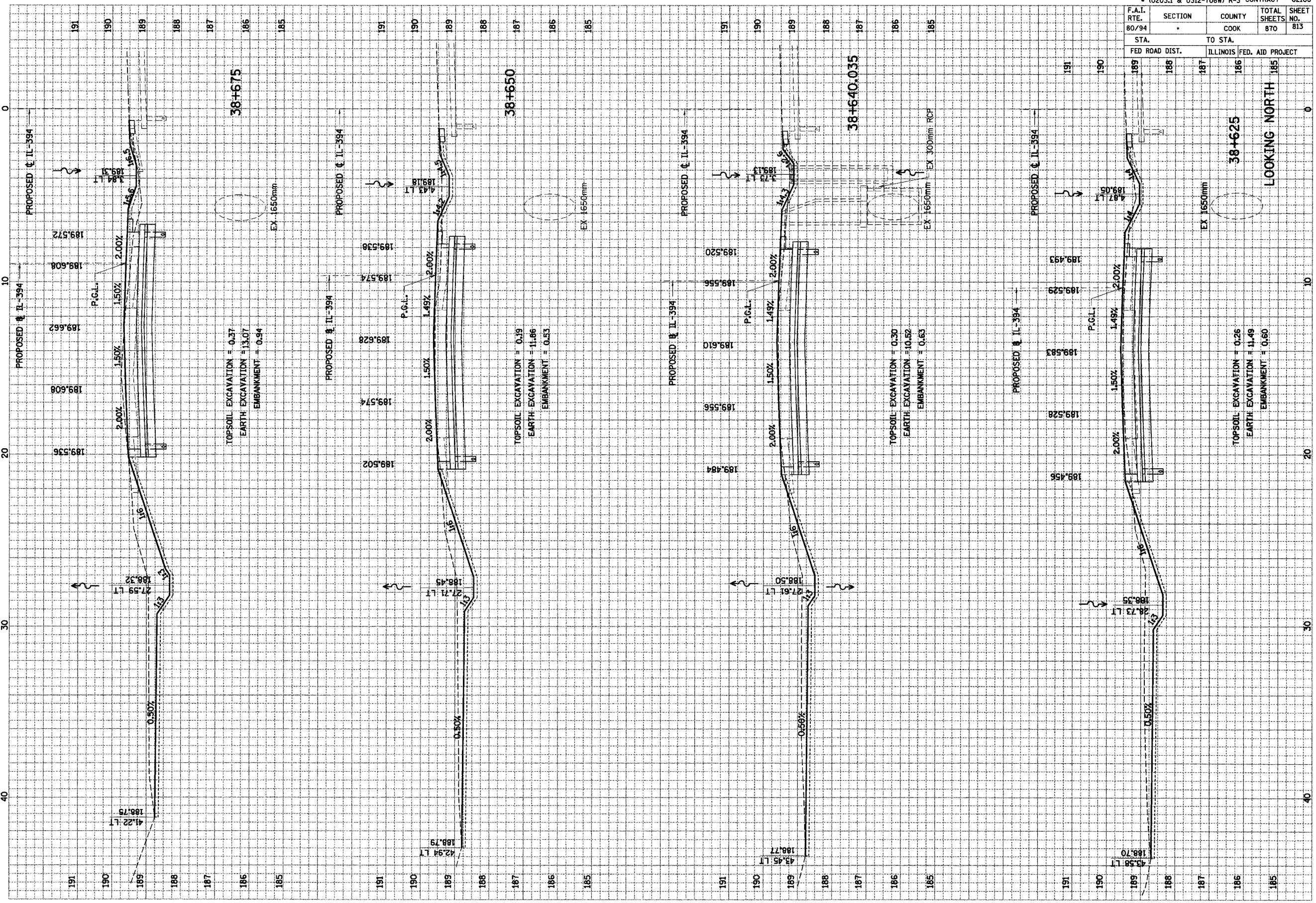



* (0203.1 & 0312-708W) R-3 CONTRACT * 62108			
F.A.I. RTE.	SECTION	COUNTY	TOTAL SHEETS NO.
80/94		COOK	870
STA. TO STA.		ILLINOIS FED. AID PROJECT	
188	187	186	185

FINAL SURVEY	DATE
SUBMITTED	BY
PLOTTED	
TEMPLATE	
NOTE BOOK	
AREAS CHECKED	

ORIGINAL SURVEY	DATE
SUBMITTED	BY
PLOTTED	
TEMPLATE	
NOTE BOOK	
AREAS CHECKED	

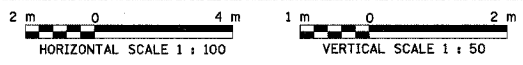
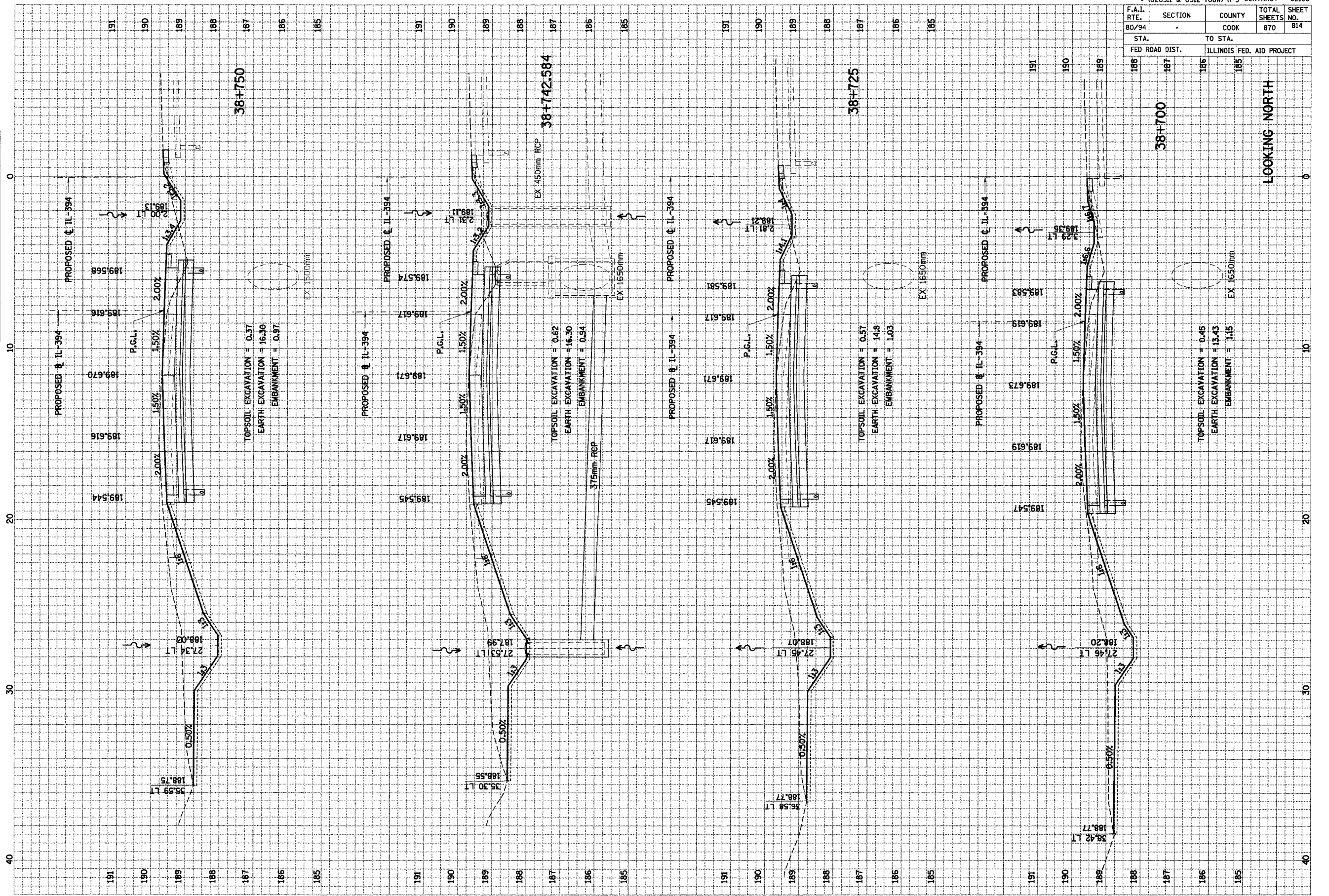



F.A.I. RTE.	SECTION	COUNTY	TOTAL SHEETS	SHEET NO.
80/94	-	COOK	870	815
STA. TO STA.		ILLINOIS FED. AID PROJECT		
FED ROAD DIST.				

FINAL SURVEY	REVISIONS	DATE
NOTE BOOK	PLOTTED	
NO.	TEMPLATE	
	AREAS CHECKED	

ORIGINAL SURVEY	REVISIONS	DATE
NOTE BOOK	PLOTTED	
NO.	TEMPLATE	
	AREAS CHECKED	

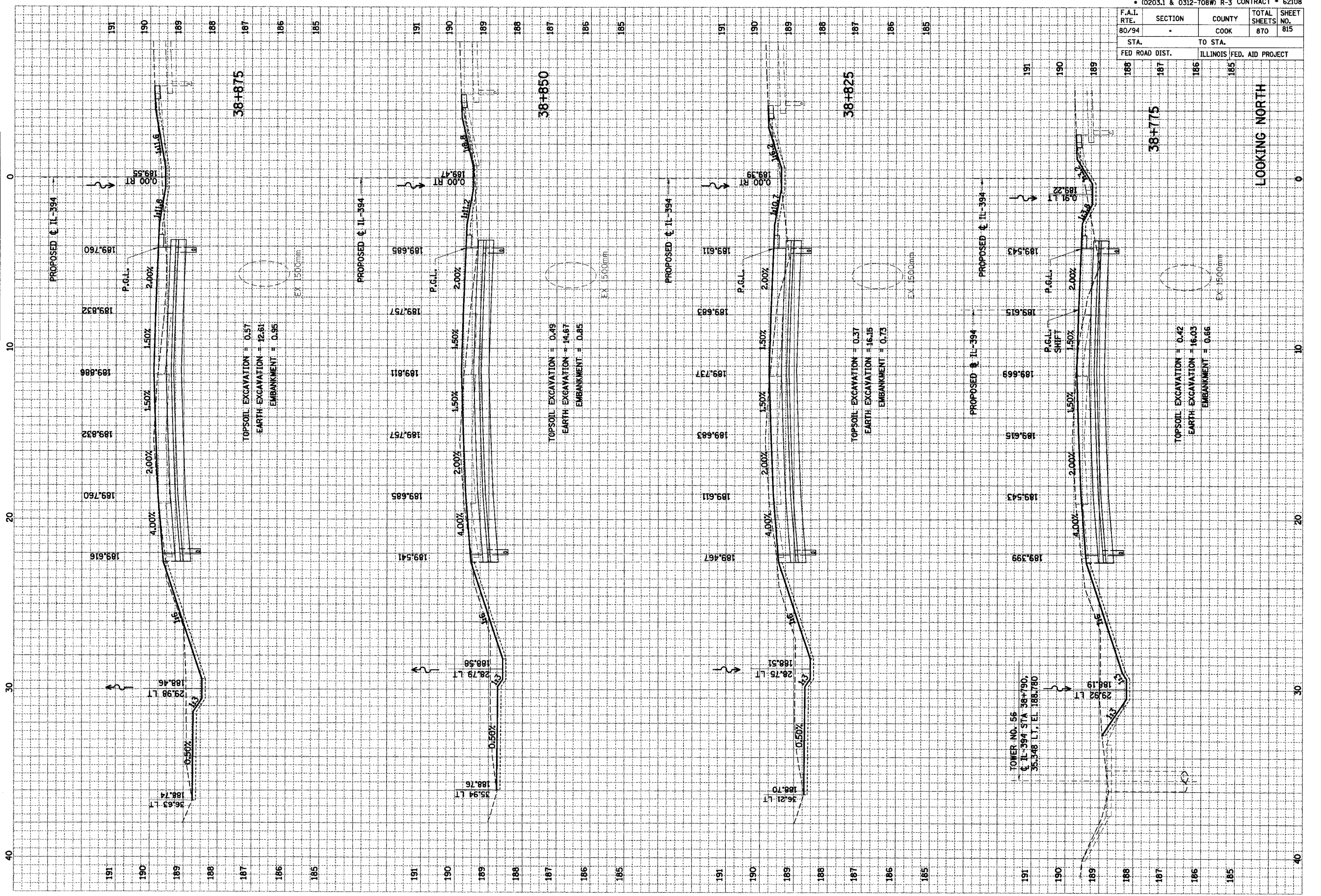

F.A.I. RTE.	SECTION	COUNTY	TOTAL SHEETS NO.	SHEET NO.
80/94		COOK	870	816
STA. 188 TO STA. 187		ILLINOIS FED. AID PROJECT		

FINAL SURVEY	BY	DATE
PLOTTED		
NOTE BOOK		
AREAS CHECKED		

ORIGINAL SURVEY	BY	DATE
PLOTTED		
NOTE BOOK		
AREAS CHECKED		

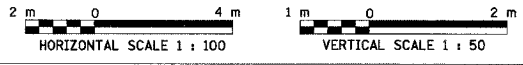
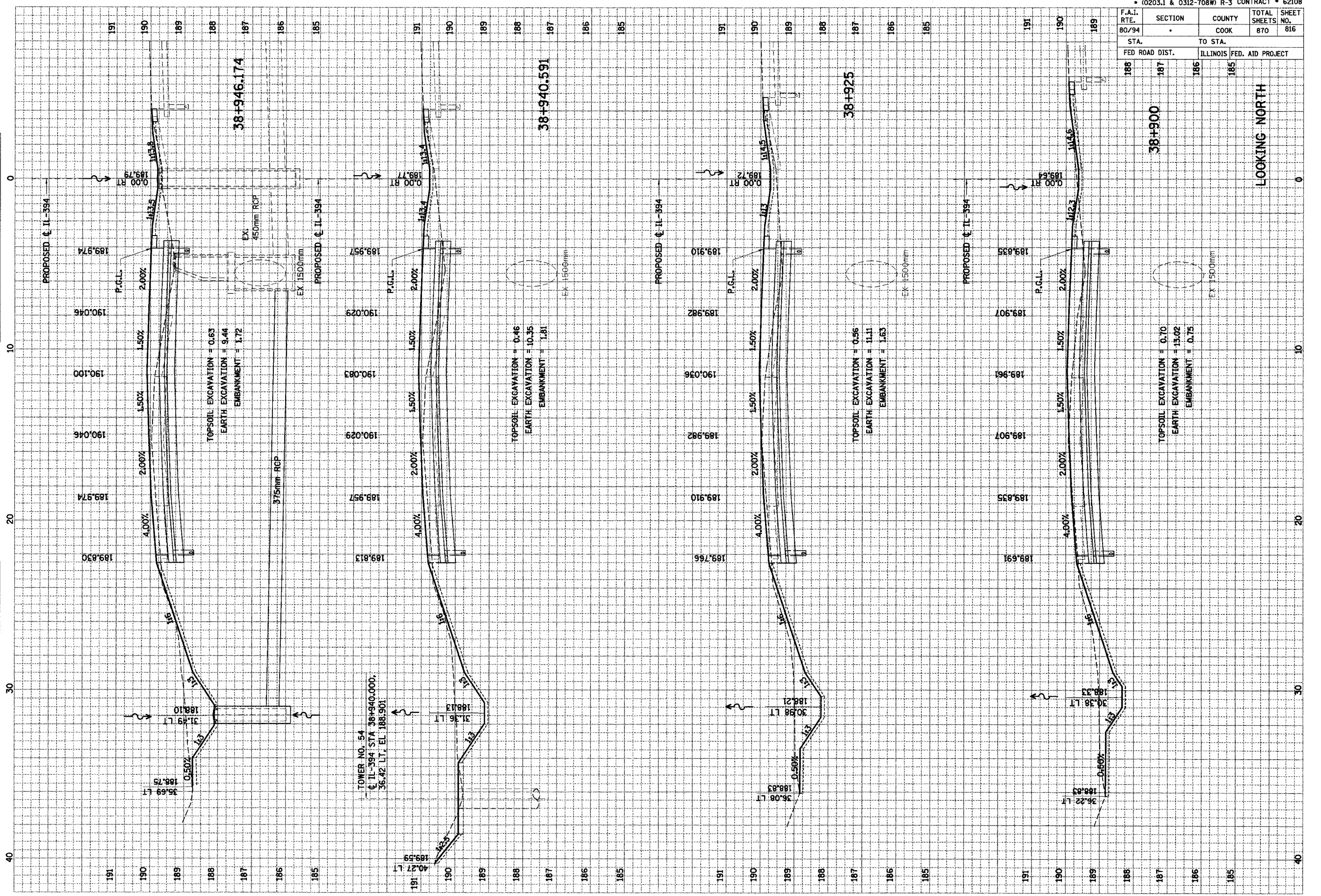



F.A.I. RTE.	SECTION	COUNTY	TOTAL SHEETS	SHEET NO.
80/94		COOK	870	817
STA. 188 TO STA. 185		ILLINOIS FED. AID PROJECT		

FINAL SURVEY	SURVEYED	BY	DATE
NOTE BOOK	PLOTTED		
NO.	TEMPLATE		
	AREAS CHECKED		

ORIGINAL SURVEY	SURVEYED	BY	DATE
NOTE BOOK	PLOTTED		
NO.	TEMPLATE		
	AREAS CHECKED		

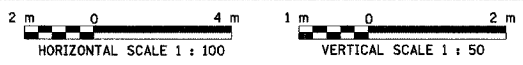
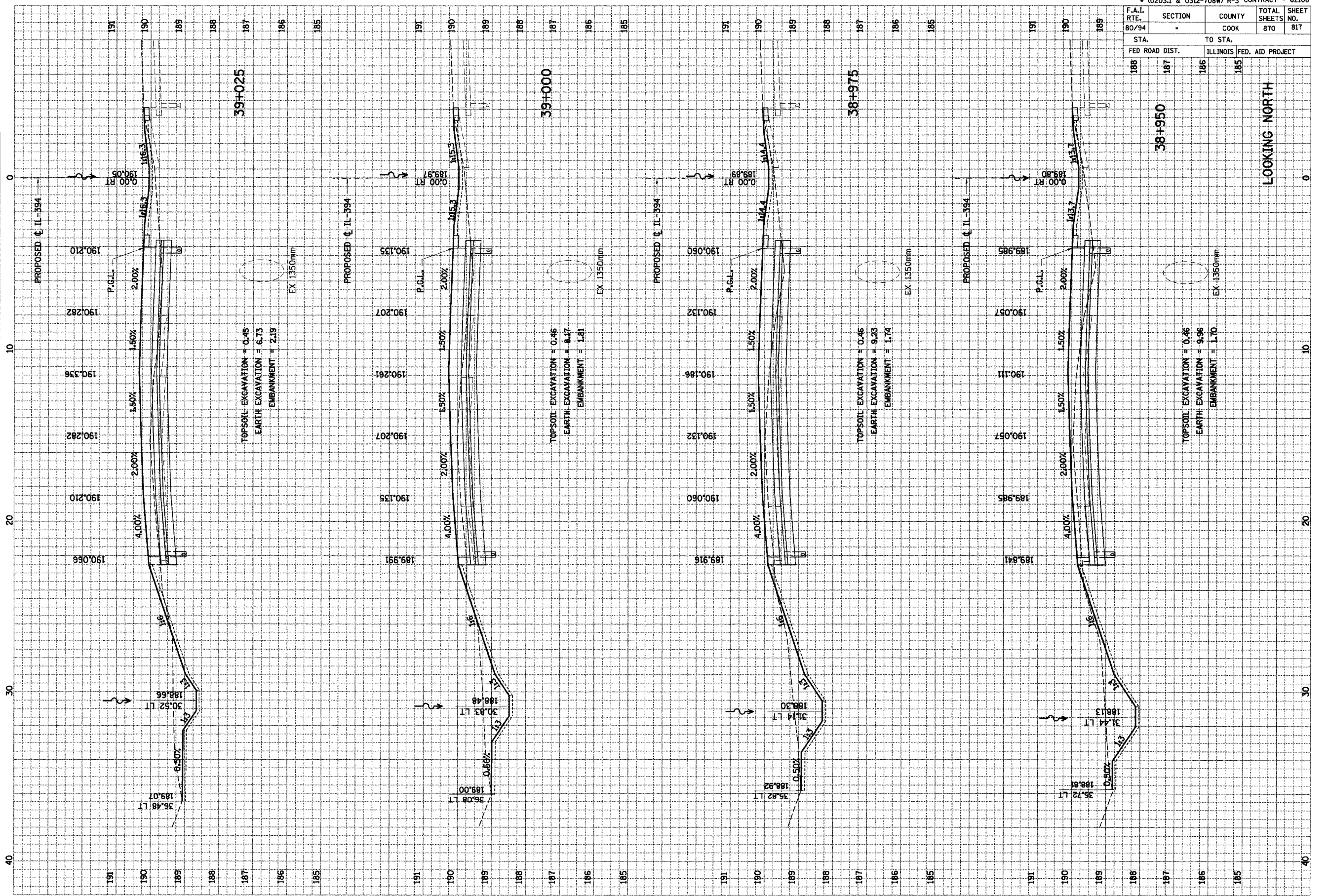



F.A.I. RTE. 80/94	SECTION •	COUNTY COOK	TOTAL SHEETS 870	SHEET NO. 818
STA. 188	TO STA. 187		ILLINOIS FED. AID PROJECT	

FINAL SURVEY	DATE
REVISIONS	BY
PLOTTED	
TEMPLATE	
NOTE BOOK	
AREAS CHECKED	

ORIGINAL SURVEY	DATE
REVISIONS	BY
PLOTTED	
TEMPLATE	
NOTE BOOK	
AREAS CHECKED	

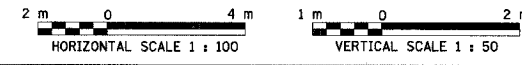
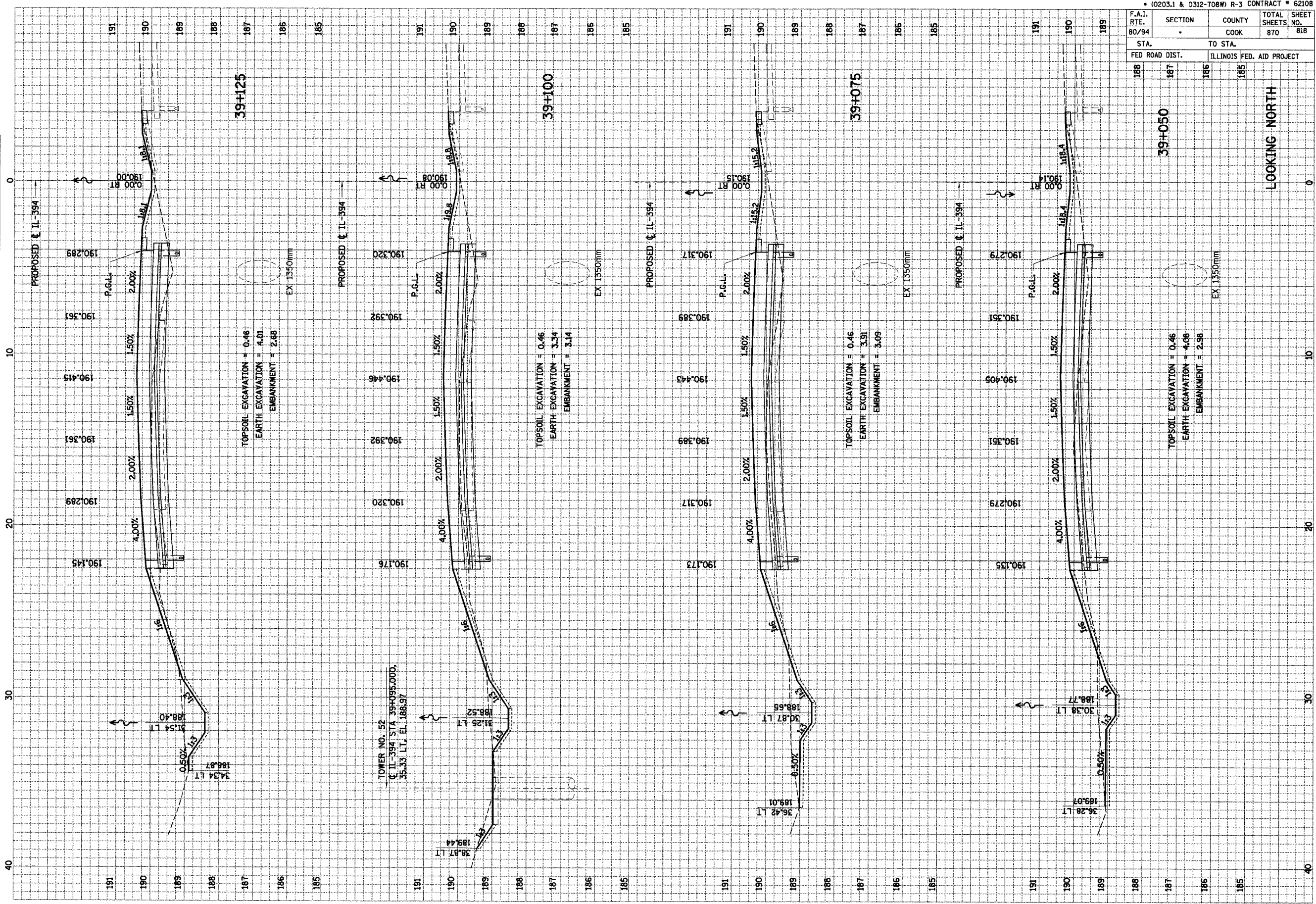

F.A.I. RTE.	SECTION	COUNTY	TOTAL SHEETS	SHEET NO.
80/94	.	COOK	870	819
STA. 188		TO STA. 185		
FED ROAD DIST.		ILLINOIS FED. AID PROJECT		

FINAL SURVEY	BY	DATE
SUBMITTED		
PLOTTED		
NOTE BOOK		
TEMPLATE		
AREAS CHECKED		

ORIGINAL SURVEY	BY	DATE
SUBMITTED		
PLOTTED		
NOTE BOOK		
TEMPLATE		
AREAS CHECKED		

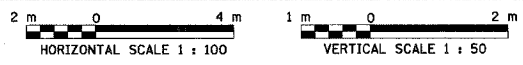
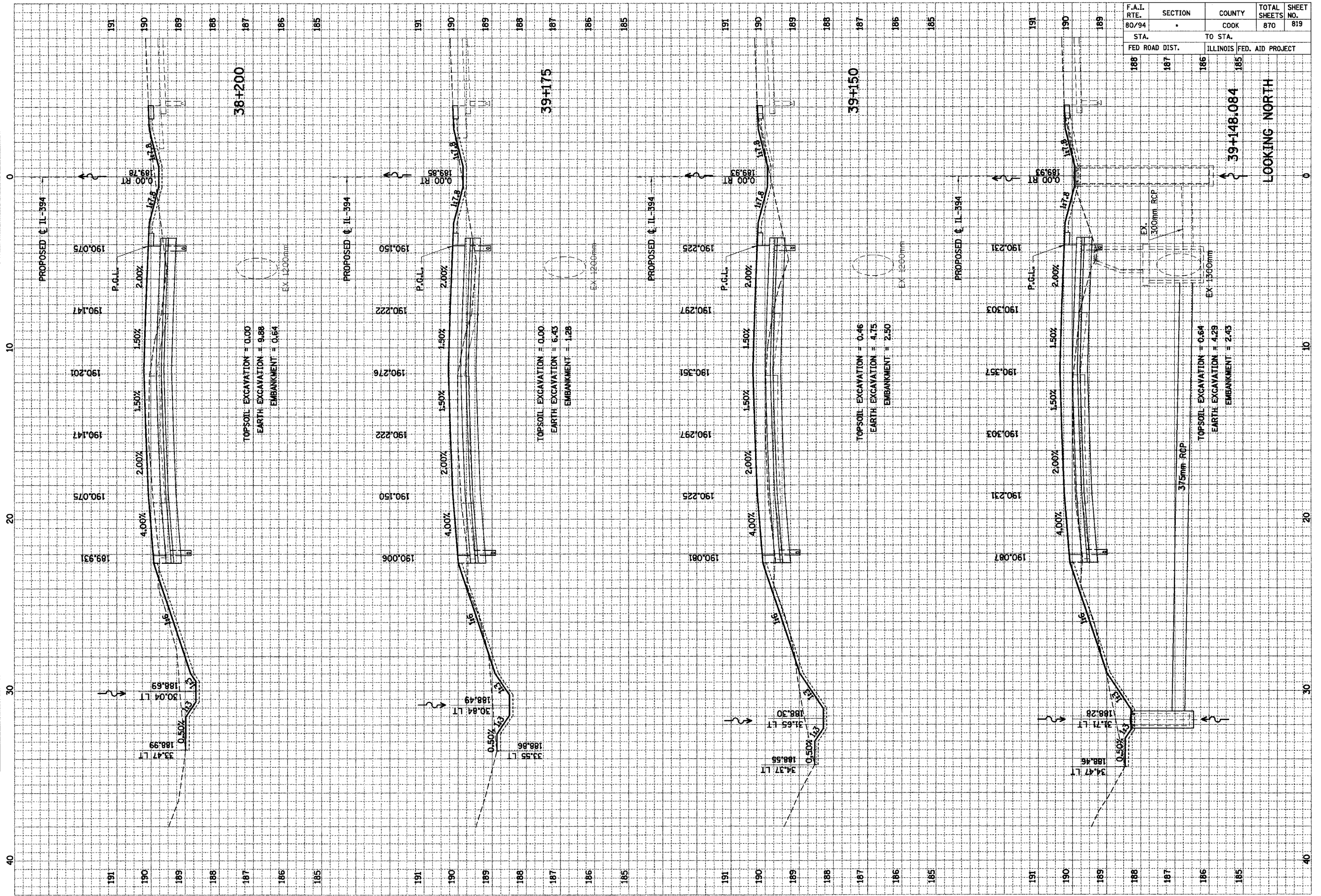



• (0203.1 & 0312-708W) R-3 CONTRACT # 62108

F.A.I. RTE.	SECTION	COUNTY	TOTAL SHEETS NO.
80/94		COOK	870
STA.	TO STA.		820
FED ROAD DIST.	ILLINOIS		FED. AID PROJECT
188	187	186	185

FINAL SURVEY	BY	DATE
FLIPPED		
REPLATE		
NOTE BOOK		
AREAS CHECKED		
NO.		

ORIGINAL SURVEY	BY	DATE
FLIPPED		
REPLATE		
NOTE BOOK		
AREAS CHECKED		
NO.		

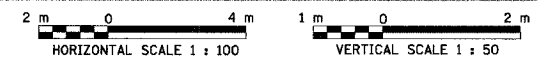
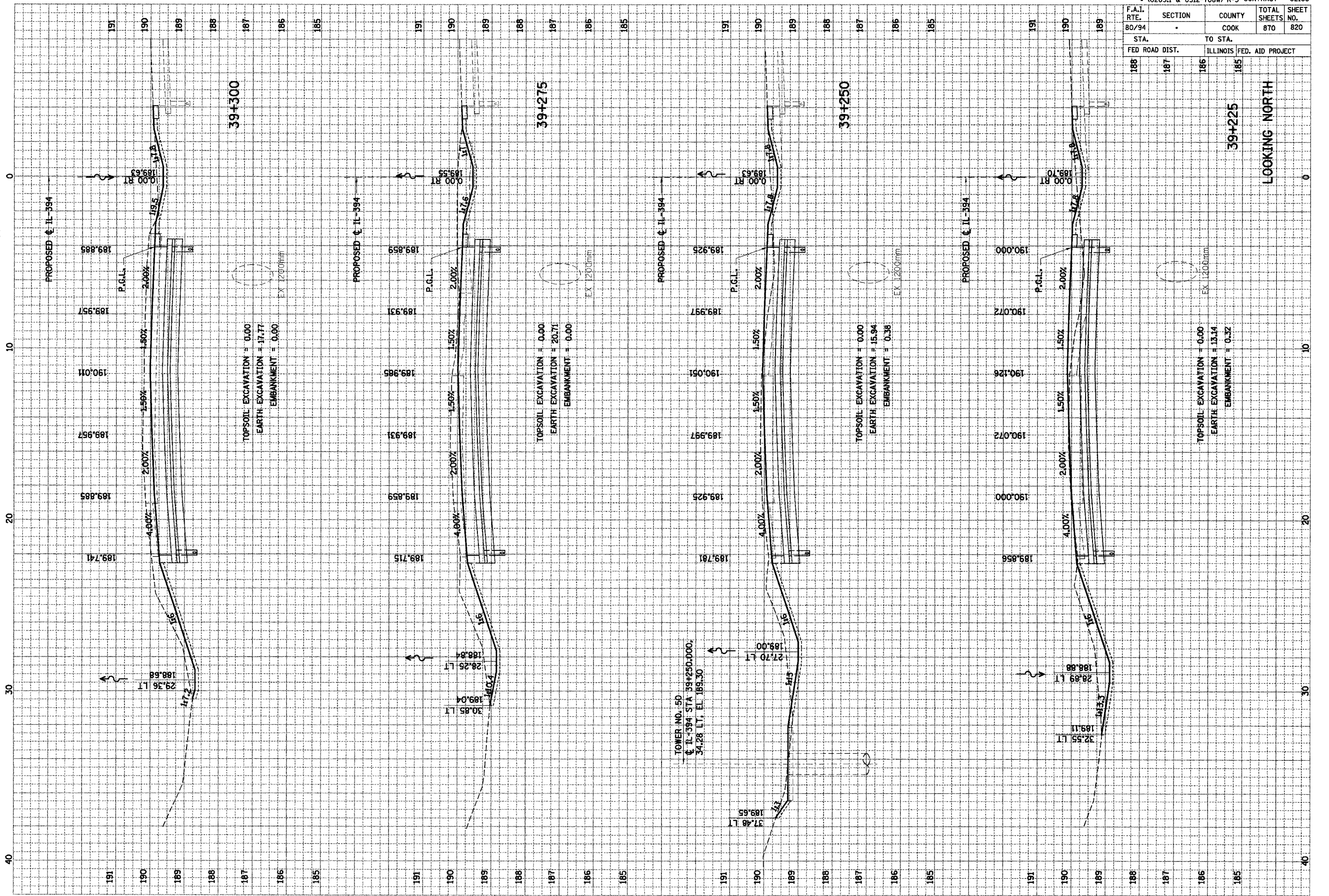





F.A.I. RTE.	SECTION	COUNTY	TOTAL SHEETS	SHEET NO.
80/94		COOK	870	822
STA. TO STA.		ILLINOIS FED. AID PROJECT		
189		186		

FINAL SURVEY	SURVEYED	BY	DATE
NOTE BOOK	PLOTTED		
NO.	TEMPLATE		
	AREAS CHECKED		

ORIGINAL SURVEY	SURVEYED	BY	DATE
NOTE BOOK	PLOTTED		
NO.	TEMPLATE		
	AREAS CHECKED		

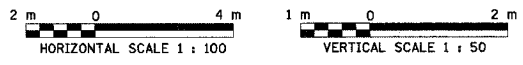
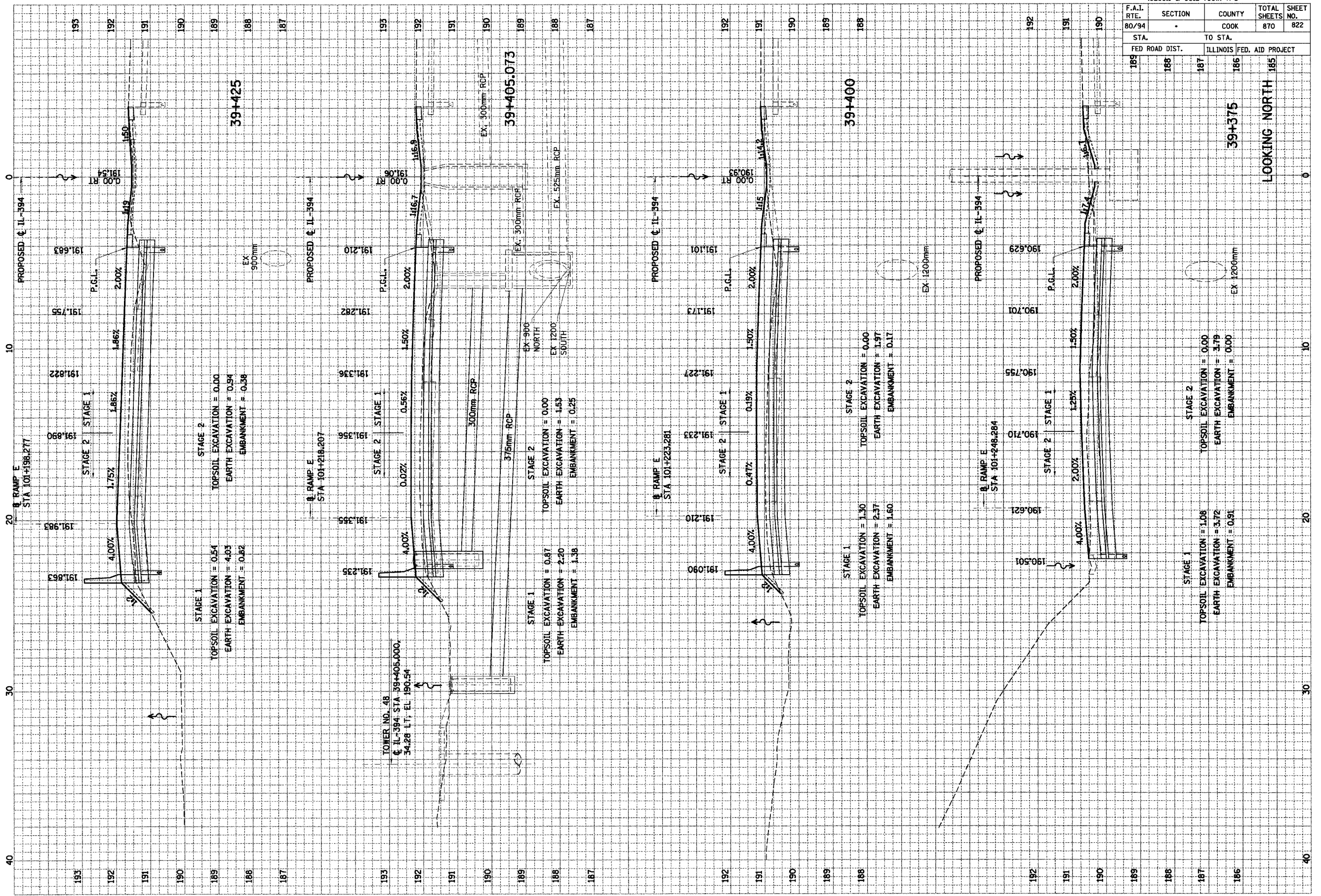



F.A.I. RTE. 80/94	SECTION •	COUNTY COOK	TOTAL SHEETS 870	SHEET NO. 823
STA. TO STA.		ILLINOIS FED. AID PROJECT		
191	190	189	188	187

FINAL SURVEY	DATE
REVISIONS	BY
NOTED	
TEMPLATE	
AREAS CHECKED	
NO.	

ORIGINAL SURVEY	DATE
REVISIONS	BY
NOTED	
TEMPLATE	
AREAS CHECKED	
NO.	

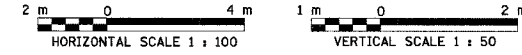
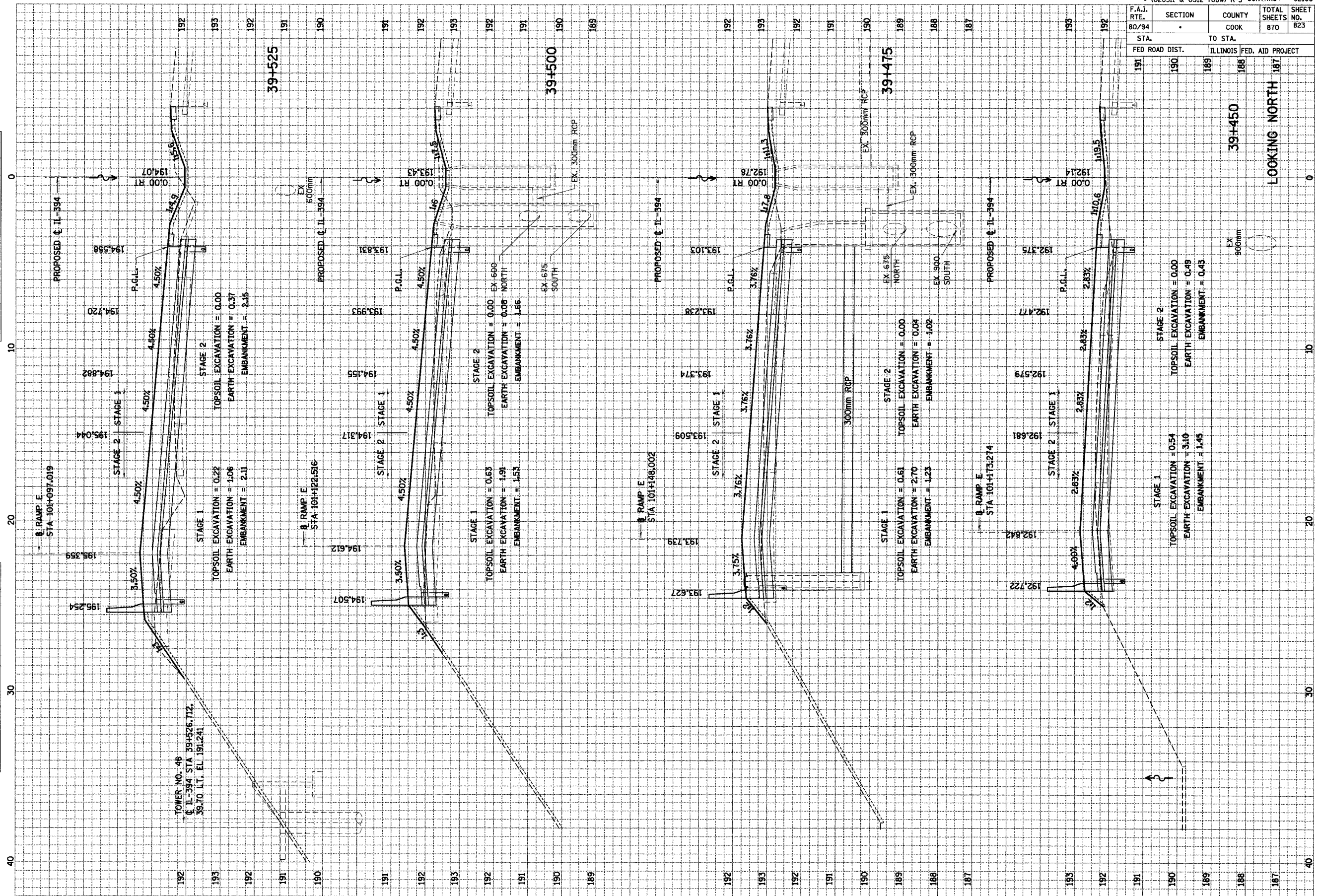

LOOKING NORTH



F.A.I. RTE.	SECTION	COUNTY	TOTAL SHEETS NO.
80/94		COOK	870
824			

STA.	TO STA.
192	191
191	190

FED ROAD DIST.	ILLINOIS FED. AID PROJECT

FINAL SURVEY	SURVEYED	BY	DATE
NOTE BOOK	PLOTTED		
	REPLATE		
	AREAS CHECKED		

ORIGINAL SURVEY	SURVEYED	BY	DATE
NOTE BOOK	PLOTTED		
	REPLATE		
	AREAS CHECKED		

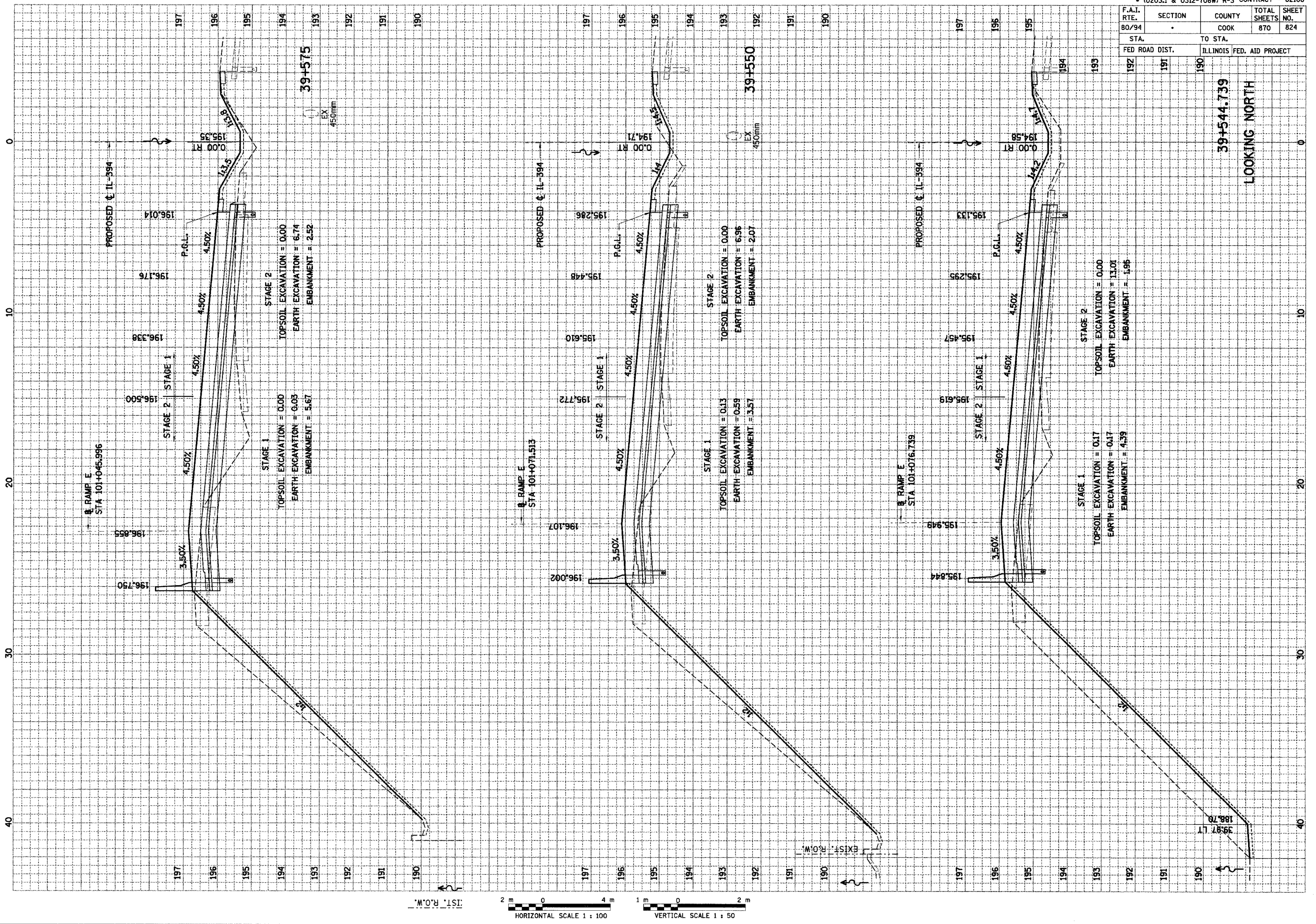

F.A.I. RTE.	SECTION	COUNTY	TOTAL SHEETS	SHEET NO.
80/94		COOK	870	825

STA.	TO STA.
FED ROAD DIST. 194	ILLINOIS FED. AID PROJECT 191
193	190

FINAL SURVEY	BY	DATE
PLOTTED		
REPLATE		
NO. AREAS CHECKED		

ORIGINAL SURVEY	BY	DATE
PLOTTED		
REPLATE		
NO. AREAS CHECKED		



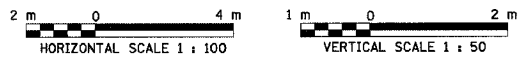
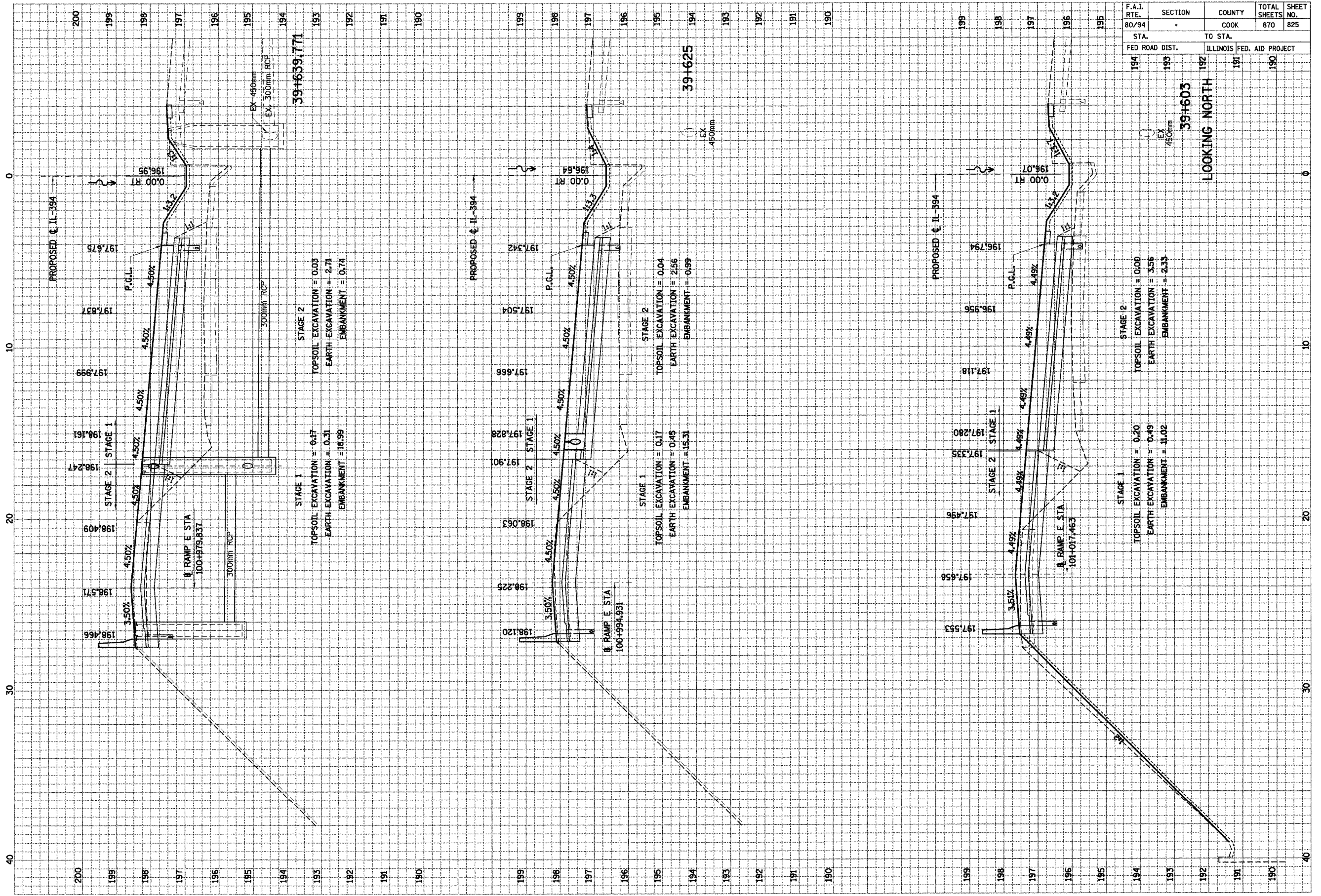

F.A.I. RTE.	SECTION	COUNTY	TOTAL SHEETS	SHEET NO.
80/94		COOK	870	826
STA.	TO STA.			
FED ROAD DIST.	ILLINOIS FED. AID PROJECT			
194	193	192	191	190

FINAL SURVEY	REWORKED	DATE
NO.	NO.	
AREAS CHECKED	AREAS CHECKED	

ORIGINAL SURVEY	REWORKED	DATE
NO.	NO.	
AREAS CHECKED	AREAS CHECKED	

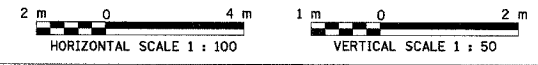
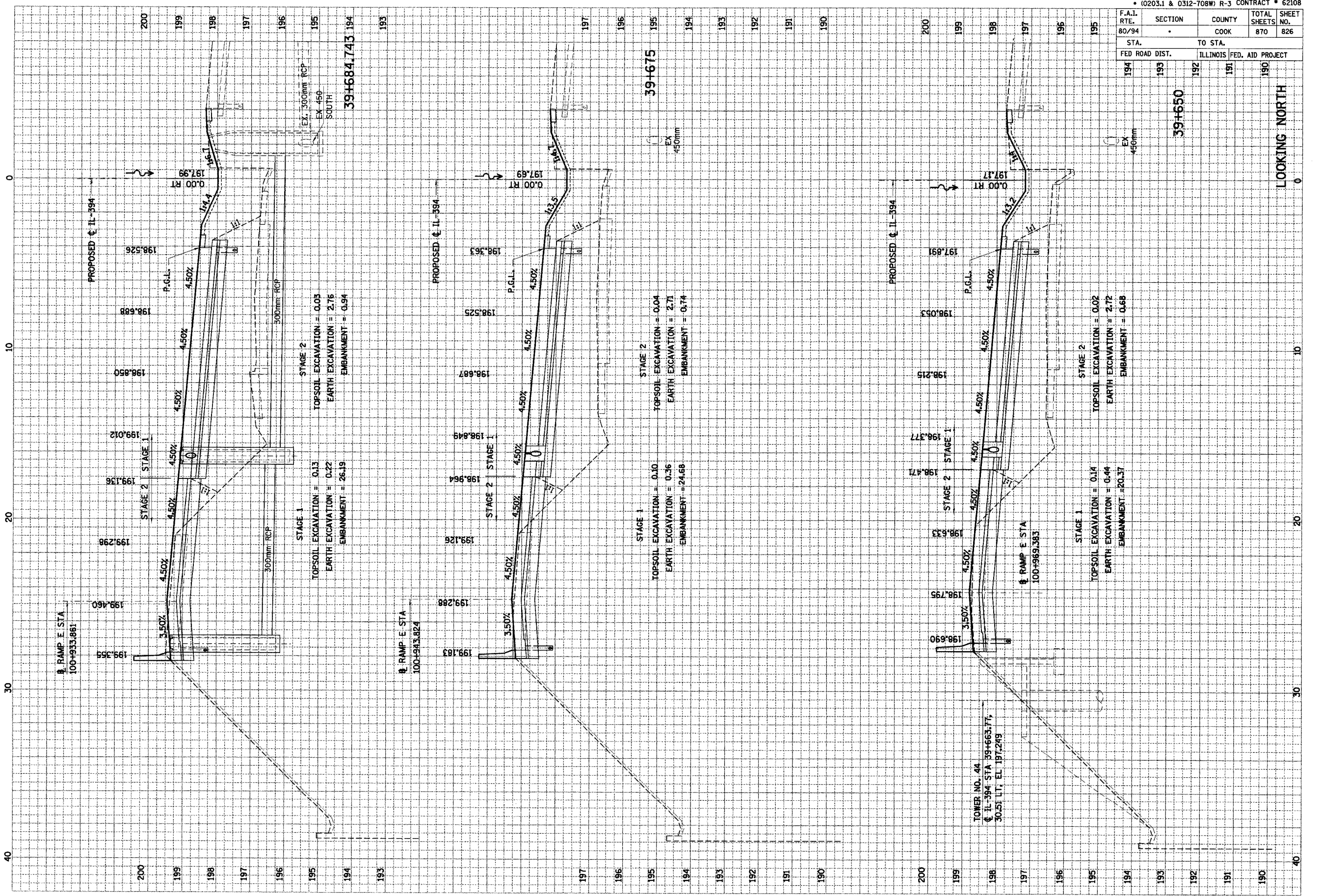



F.A.I. RTE.	SECTION	COUNTY	TOTAL SHEETS	SHEET NO.
80/94	-	COOK	870	827
STA. TO STA.		ILLINOIS FED. AID PROJECT		
196	195	194	193	192

FINAL SURVEYING	BY	DATE
SURVEY PLOTTED		
NOTE BOOK TEMPLATE		
AREAS CHECKED		

ORIGINAL SURVEYING	BY	DATE
SURVEY PLOTTED		
NOTE BOOK TEMPLATE		
AREAS CHECKED		

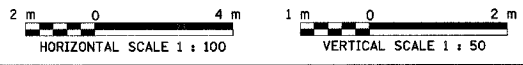
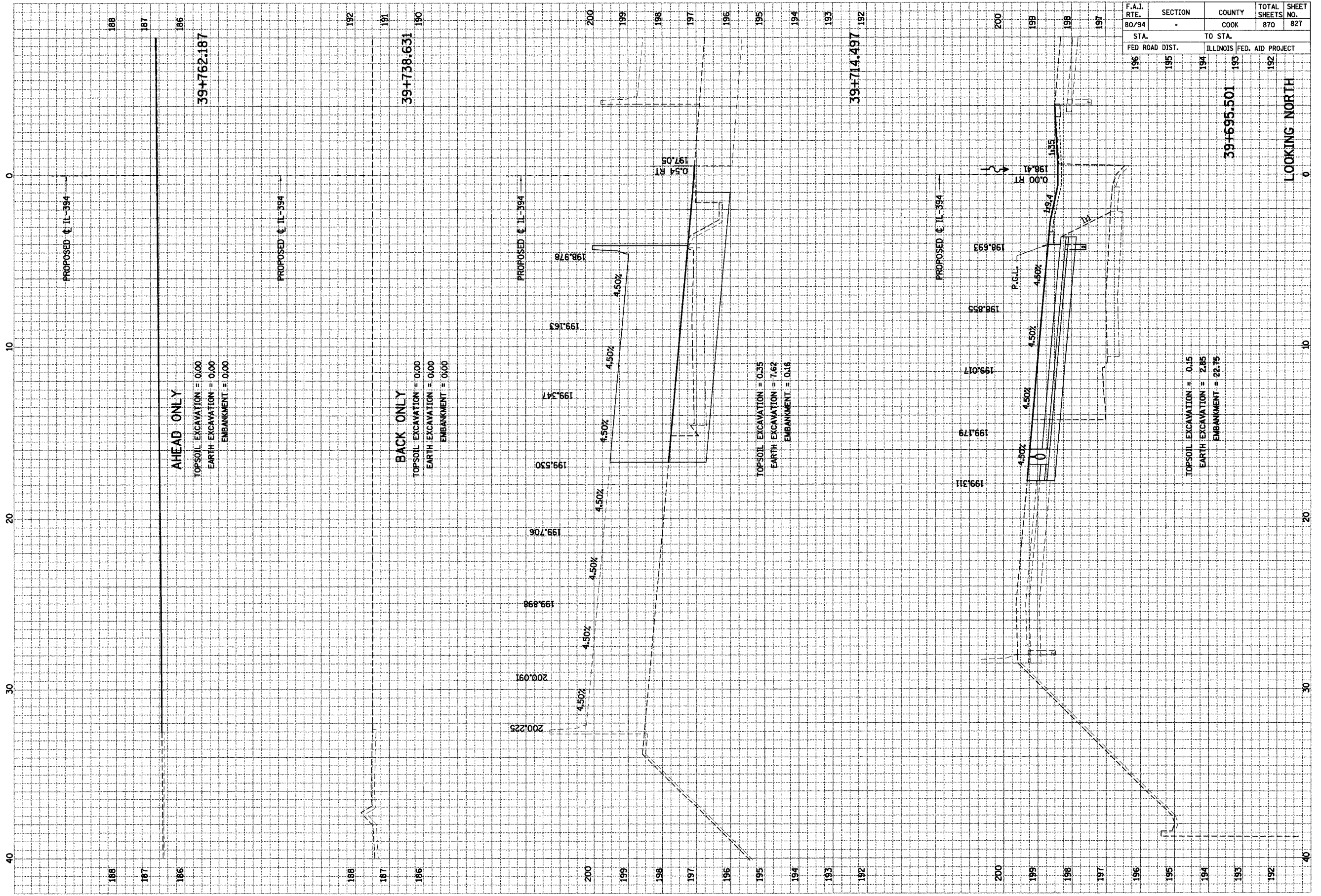

F.A.I. RTE. 80/94	SECTION	COUNTY	TOTAL SHEETS	SHEET NO.
		COOK	870	828

STA. TO STA.	FED. ROAD DIST.	ILLINOIS FED. AID PROJECT
197	196	194
	195	193

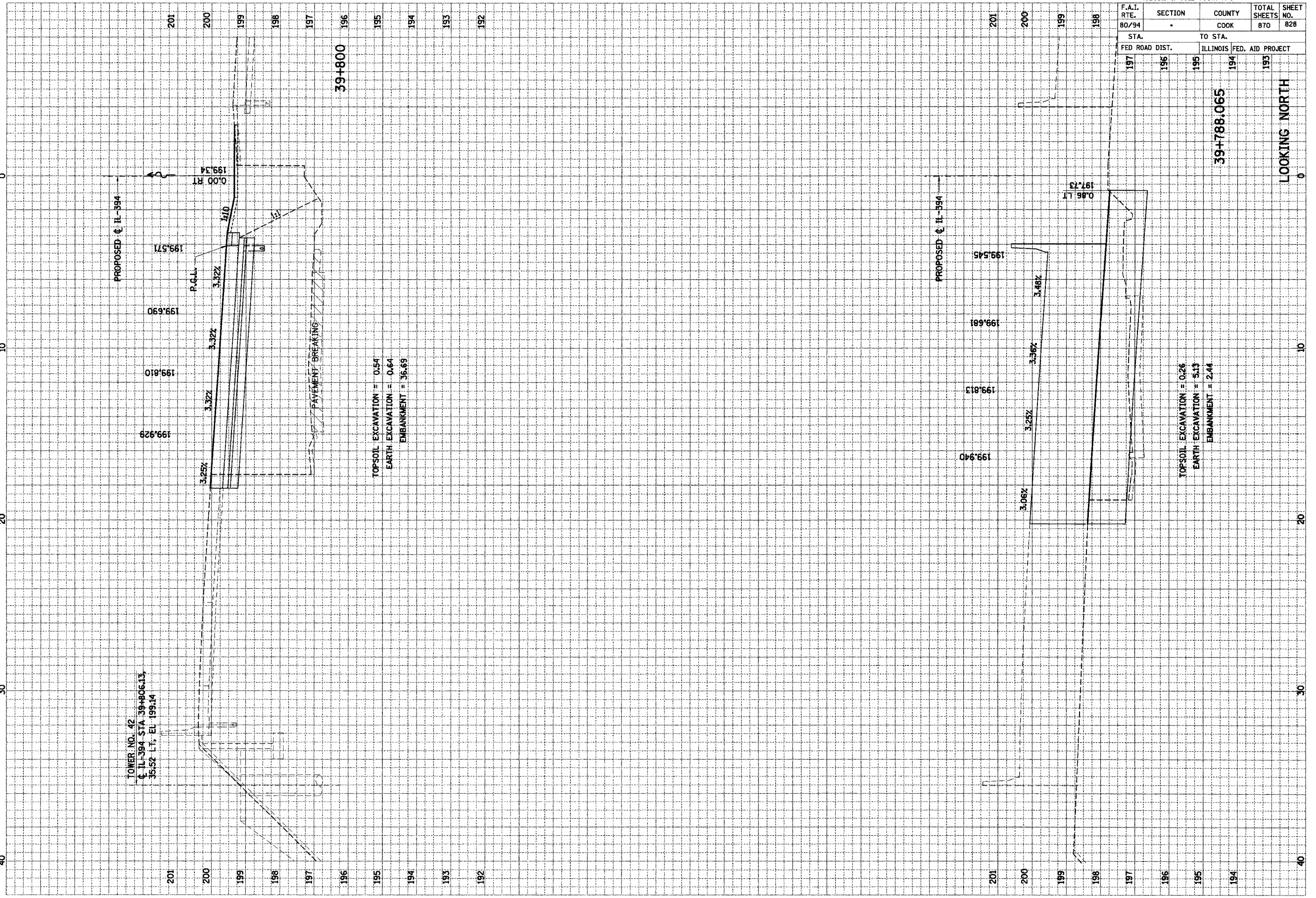

FINAL SURVEY	CORRECTED	BY	DATE
NOTE BOOK	PLOTTED		
NO.	AREAS CHECKED		

ORIGINAL SURVEY	CORRECTED	BY	DATE
NOTE BOOK	PLOTTED		
NO.	AREAS CHECKED		

TOPSOIL EXCAVATION = 0.54  
 EARTH EXCAVATION = 0.64  
 EMBANKMENT = 36.69

TOPSOIL EXCAVATION = 0.26  
 EARTH EXCAVATION = 5.13  
 EMBANKMENT = 2.44

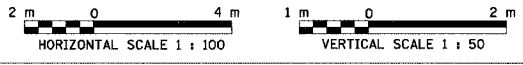



F.A.I. RTE.	SECTION	COUNTY	TOTAL SHEETS	SHEET NO.
80/94		COOK	870	829
STA. TO STA.		ILLINOIS FED. AID PROJECT		
FED ROAD DIST.		197 196 195 194 193		

FINAL SURVEY	SURVEYED	BY	DATE
NOTE BOOK NO.	PLOTTED		
	TEMPLATE		
	AREAS CHECKED		

ORIGINAL SURVEY	SURVEYED	BY	DATE
NOTE BOOK NO.	PLOTTED		
	TEMPLATE		
	AREAS CHECKED		

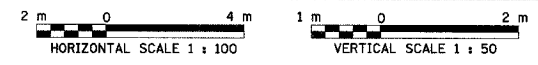
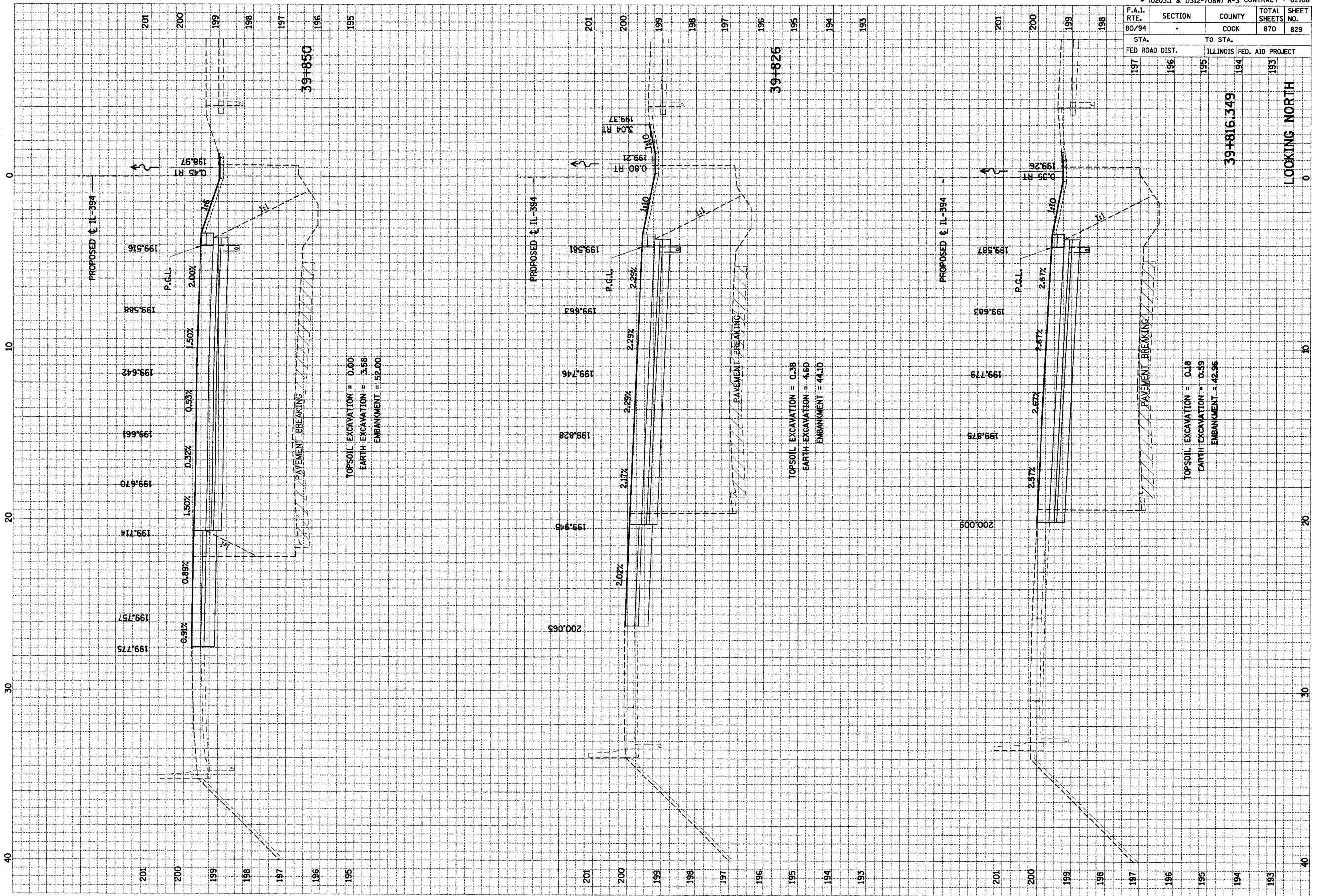

F.A.I. RTE.	SECTION	COUNTY	TOTAL SHEETS	SHEET NO.
80/94	.	COOK	870	830

STA.	TO STA.
FED ROAD DIST. 196	ILLINOIS FED. AID PROJECT 193

FINAL SURVEY	NO.	BY	DATE
SURVEYED			
PLOTTED			
REPLATE			
NOTE BOOK			
AREAS CHECKED			

ORIGINAL SURVEY	NO.	BY	DATE
SURVEYED			
PLOTTED			
REPLATE			
NOTE BOOK			
AREAS CHECKED			



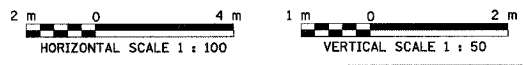
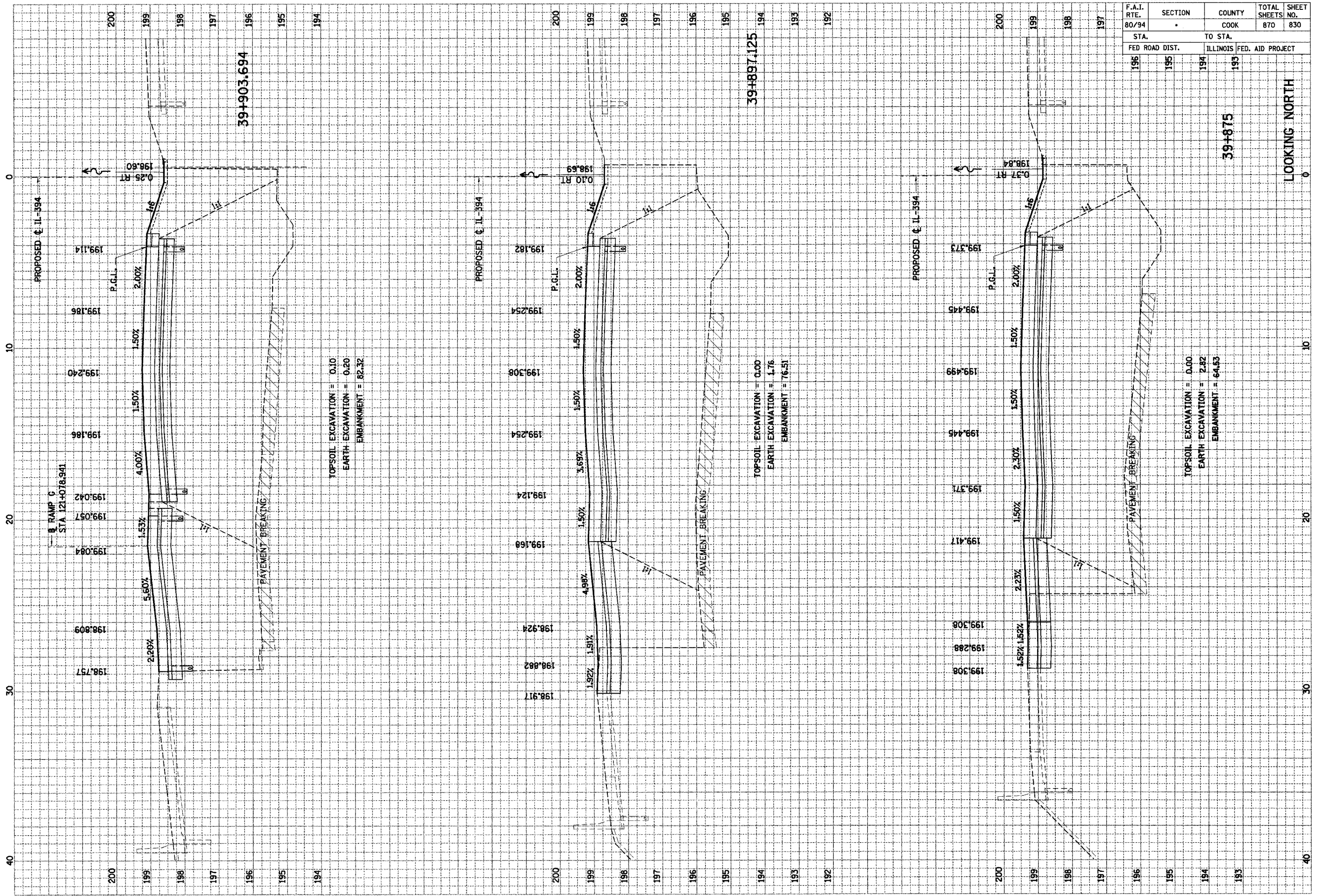

• (0203.1 & 0312-708W) R-3 CONTRACT • 62108

F.A.I. R.TE.	SECTION	COUNTY	TOTAL SHEETS NO.	SHEET NO.
80/94		COOK	870	831
STA. 195		TO STA. 193		
FED ROAD DIST. 195		ILLINOIS FED. AID PROJECT		

FINAL SURVEY	SURVEYED	BY	DATE
NOTE BOOK	PLOTTED		
AREAS	DATE		
CHECKED			

ORIGINAL SURVEY	SURVEYED	BY	DATE
NOTE BOOK	PLOTTED		
AREAS	DATE		
CHECKED			

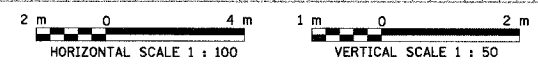
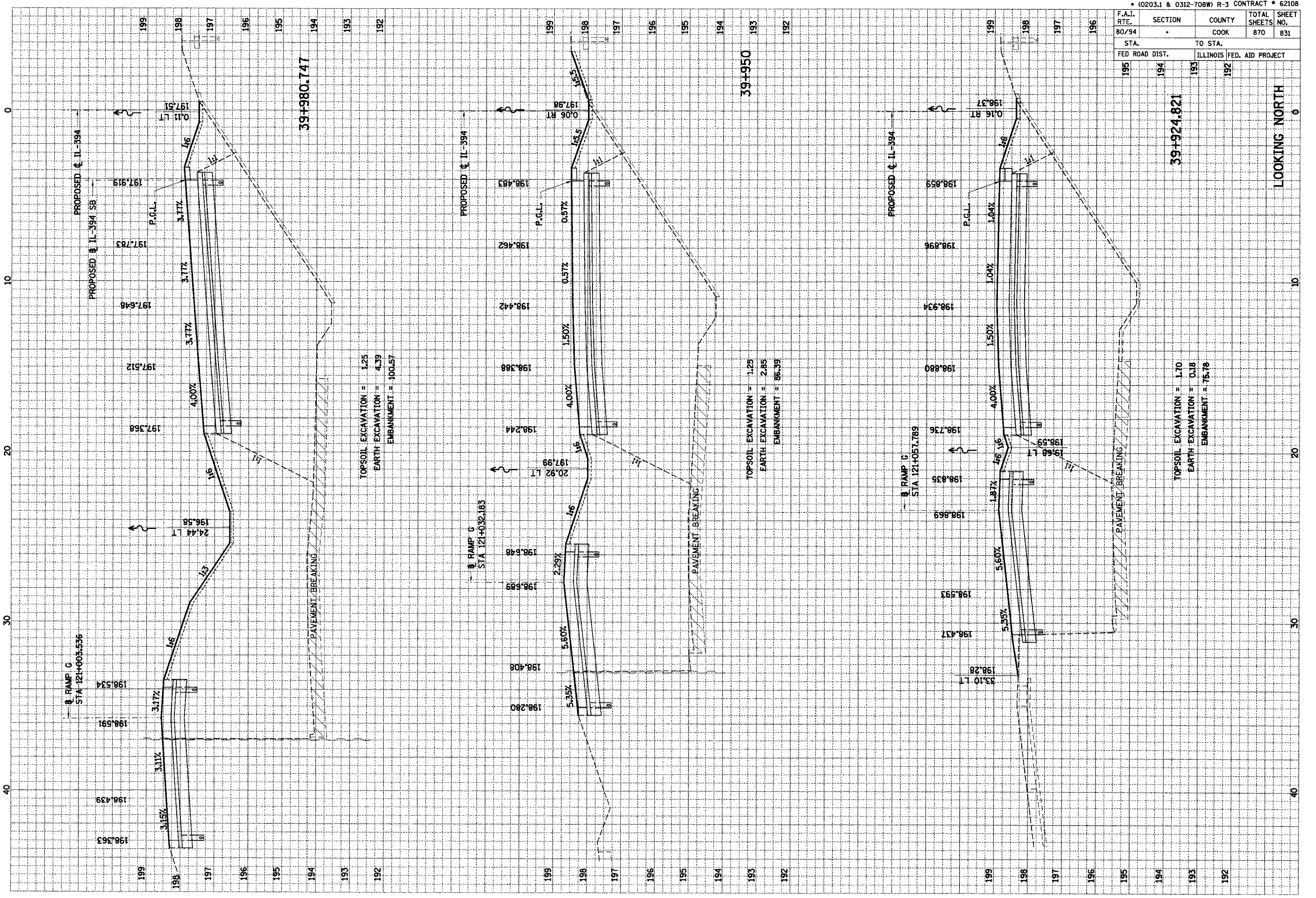

• (0203.1 & 0312-708W) R-3 CONTRACT # 62108

F.A.I. RTE.	SECTION	COUNTY	TOTAL SHEETS	SHEET NO.
80/94		COOK	870	832
STA. TO STA.		ILLINOIS FED. AID PROJECT		
193	192			

FINAL SURVEY	SURVEYED	BY	DATE
NOTE BOOK	PLOTTED		
NO.	TEMPLATE		
	AREAS CHECKED		

ORIGINAL SURVEY	SURVEYED	BY	DATE
NOTE BOOK	PLOTTED		
NO.	TEMPLATE		
	AREAS CHECKED		

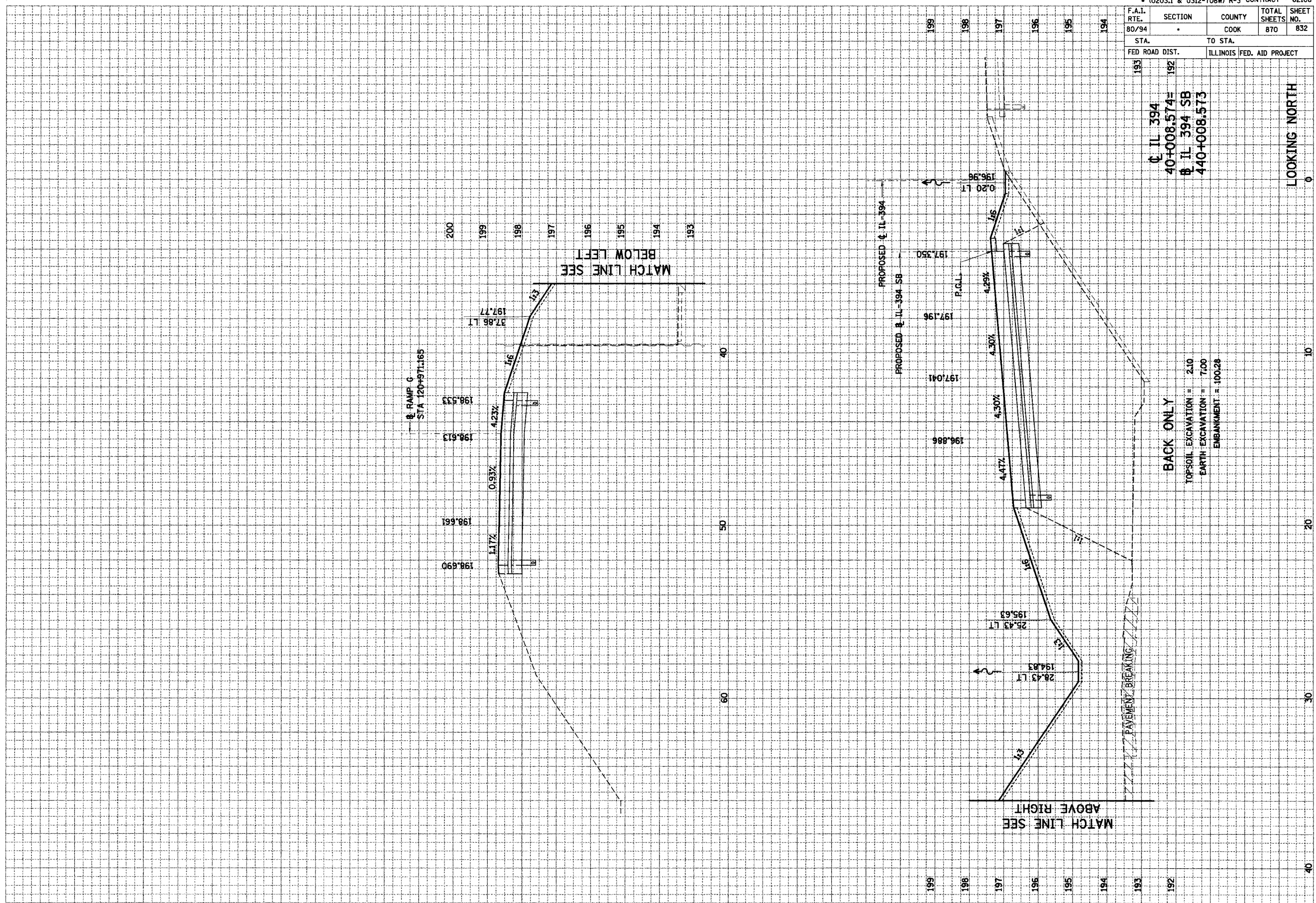





• (0203.1 & 0312-708W) R-3 CONTRACT # 62108				
F.A.I. RTE.	SECTION	COUNTY	TOTAL SHEETS	SHEET NO.
80/94		COOK	870	834
STA.		TO STA.		
FED ROAD DIST.		ILLINOIS FED. AID PROJECT		

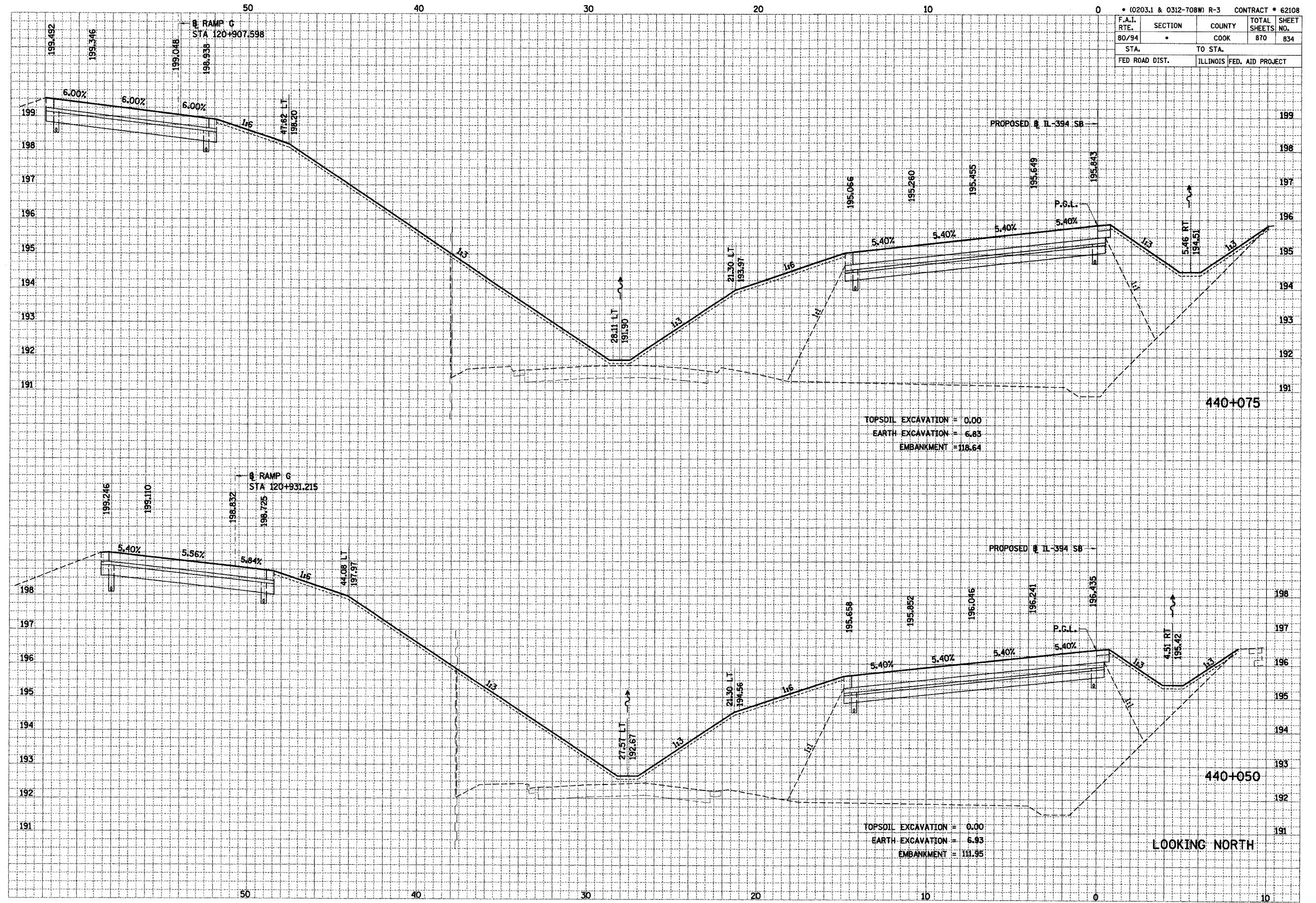

FINAL SURVEY BY DATE

SURVEYED BY \_\_\_\_\_ DATE \_\_\_\_\_

NOTE BOOK NO. \_\_\_\_\_

TEMP. PLATE \_\_\_\_\_

AREAS CHECKED \_\_\_\_\_

ORIGINAL SURVEY BY DATE

SURVEYED BY \_\_\_\_\_ DATE \_\_\_\_\_

NOTE BOOK NO. \_\_\_\_\_

TEMP. PLATE \_\_\_\_\_

AREAS CHECKED \_\_\_\_\_

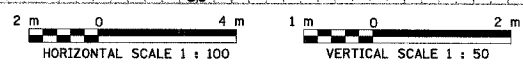



• (0203.1 & 0312-708W) R-3 CONTRACT # 62108

F.A.I. RTE.	SECTION	COUNTY	TOTAL SHEETS	SHEET NO.
80/94	*	COOK	870	835
STA.		TO STA.		
FED ROAD DIST.		ILLINOIS FED. AID PROJECT		

FINAL SURVEY	BY	DATE
NOTE BOOK		
AREAS CHECKED		
NO.		

ORIGINAL SURVEY	BY	DATE
NOTE BOOK		
AREAS CHECKED		
NO.		

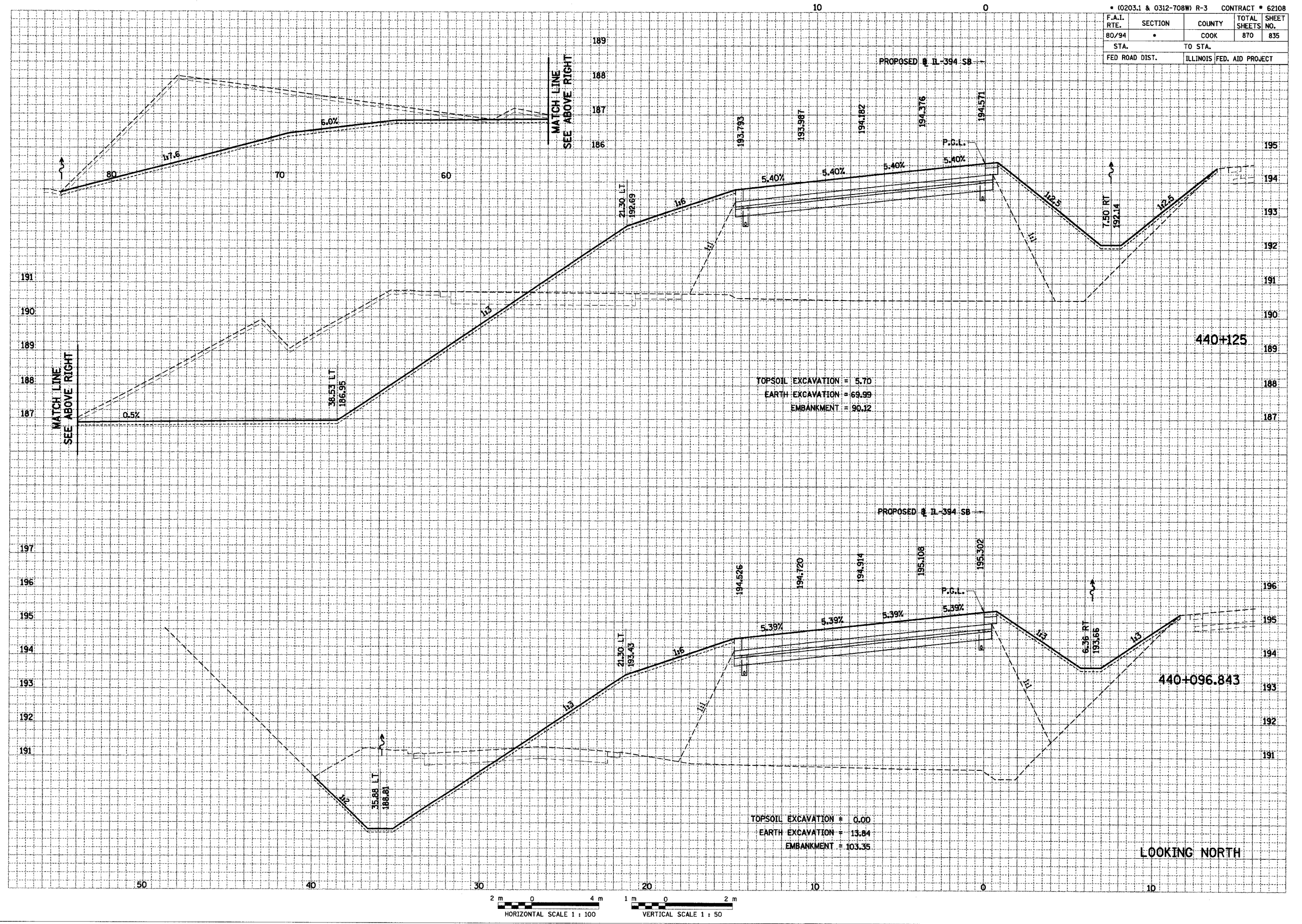

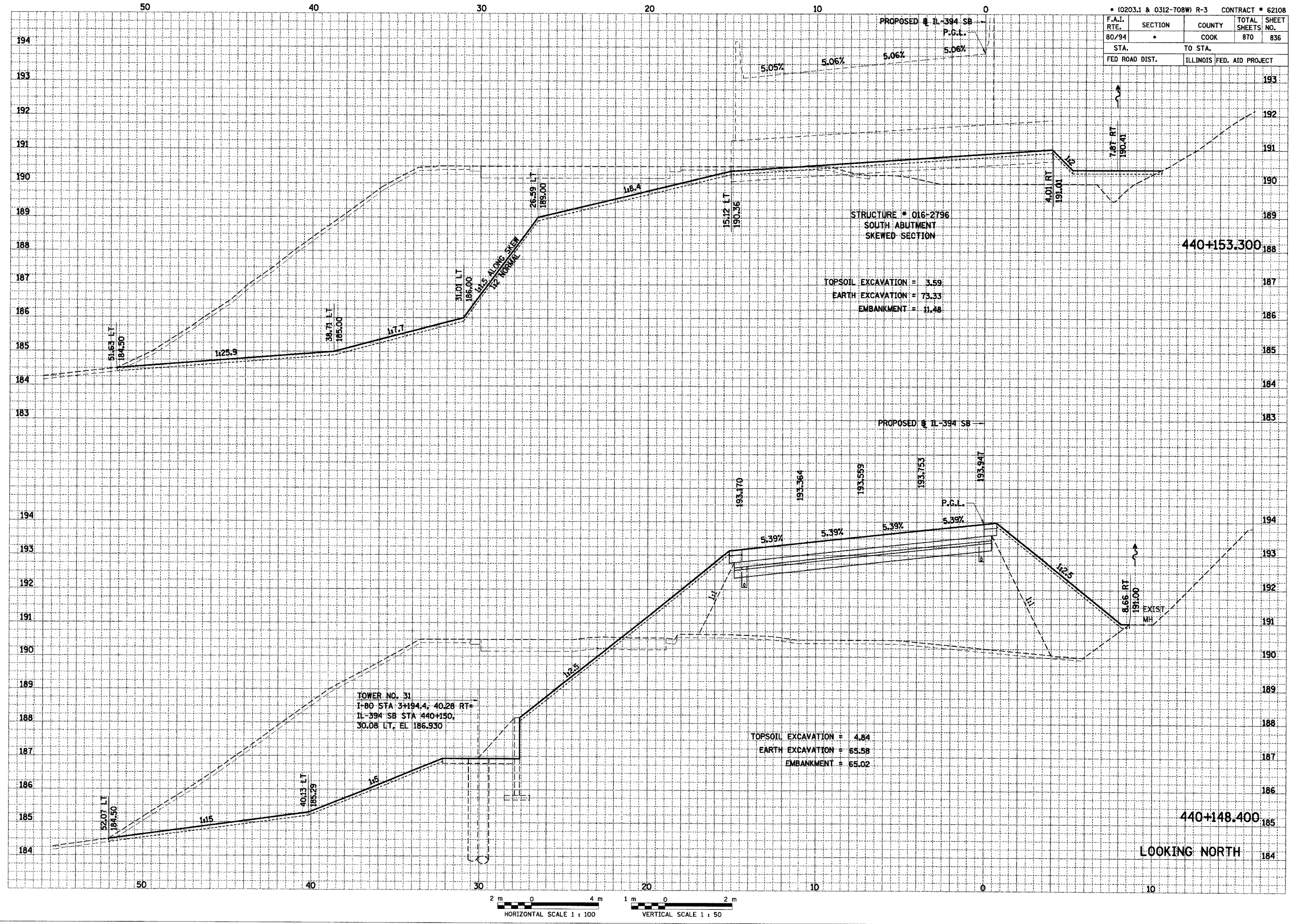

F.A.I. R.T.E.		SECTION	COUNTY	TOTAL SHEETS	SHEET NO.
80/94		*	COOK	870	836
STA.		TO STA.			
FED ROAD DIST.		ILLINOIS FED. AID PROJECT			

FINAL SURVEY	DATE
BY	
REVISIONS	
NO.	

ORIGINAL SURVEY	DATE
BY	
REVISIONS	
NO.	

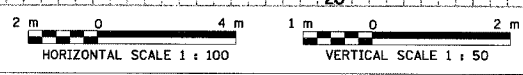





• (0203.1 & 0312-708W) R-3 CONTRACT # 62108

F.A.I. RTE.	SECTION	COUNTY	TOTAL SHEETS	SHEET NO.
80/94	•	COOK	870	838
STA.	TO STA.			
FED ROAD DIST.	ILLINOIS FED. AID PROJECT			

FINAL SURVEY	SURVEYED	DATE
NOTE BOOK	BY	
NO.	AREAS CHECKED	

ORIGINAL SURVEY	SURVEYED	DATE
NOTE BOOK	BY	
NO.	AREAS CHECKED	

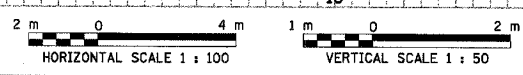
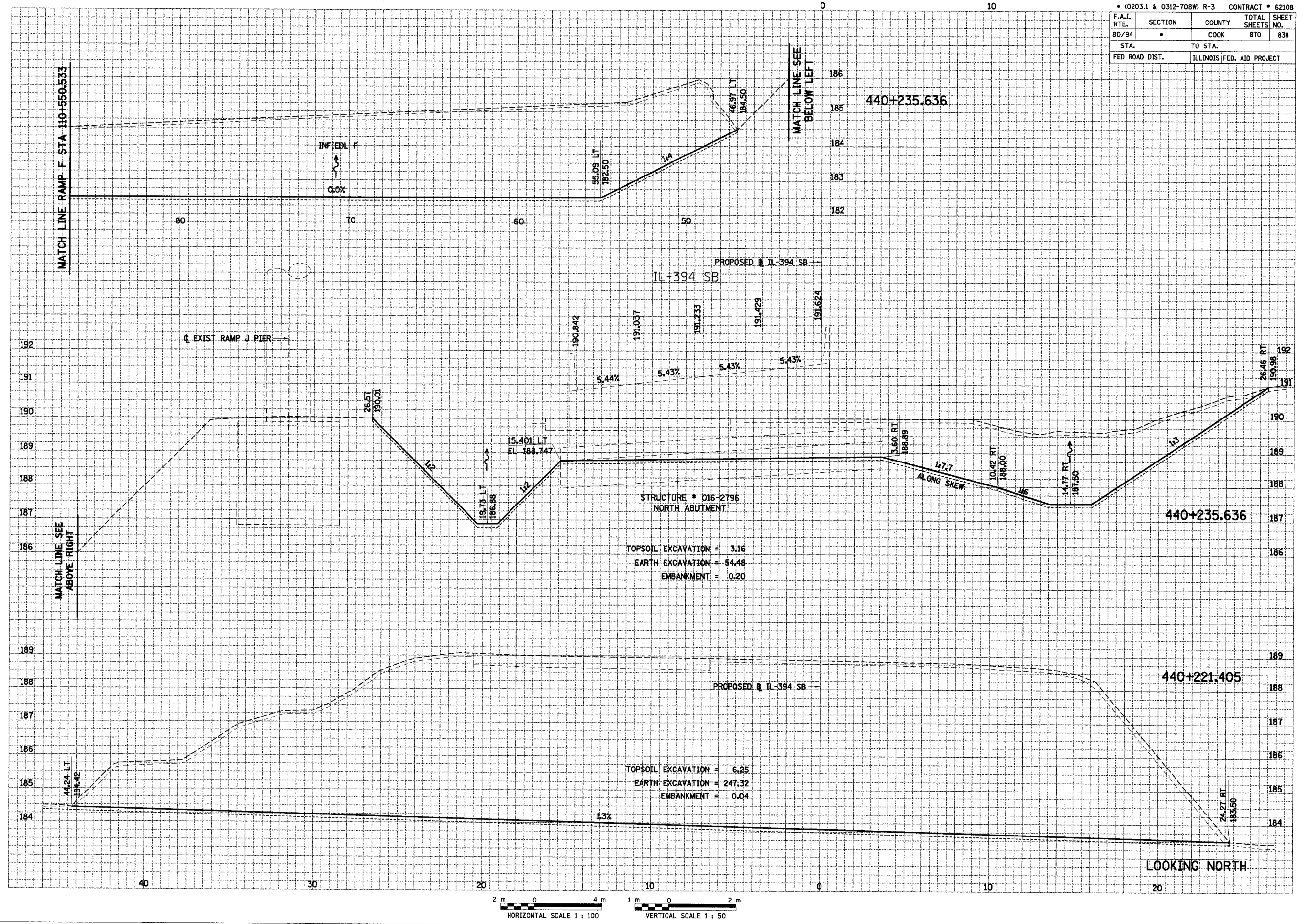



• (0203.1 & 0312-708W) R-3 CONTRACT • 62108				
F.A.I. RTE.	SECTION	COUNTY	TOTAL SHEETS	SHEET NO.
80/94	*	COOK	870	839
STA.		TO STA.		
FED ROAD DIST.		ILLINOIS FED. AID PROJECT		

FINAL SURVEY	DATE
BY	
BLANKETED SURVEY	
NOTE BOOK	
TEMPLATE	
AREAS CHECKED	
NO.	

ORIGINAL SURVEY	DATE
BY	
BLANKETED SURVEY	
NOTE BOOK	
TEMPLATE	
AREAS CHECKED	
NO.	

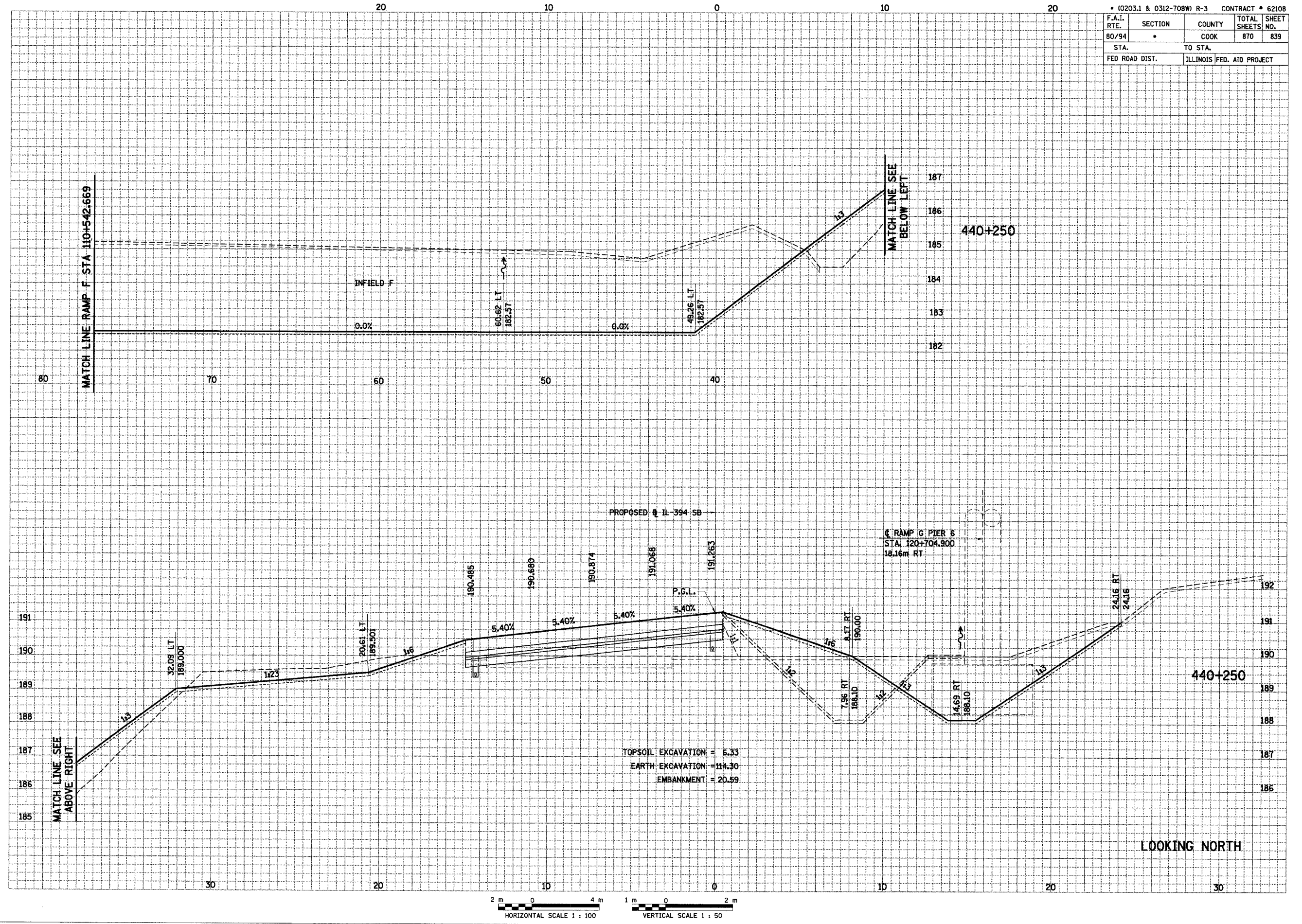

• (0203.1 & 0312-708W) R-3		CONTRACT # 62108	
F.A.I. RTE.	SECTION	COUNTY	TOTAL SHEETS
80/94	•	COOK	870
STA.		TO STA.	
FED ROAD DIST.		ILLINOIS FED. AID PROJECT	

FINAL SURVEY	SURVEYED	DATE
NOTE BOOK NO.	PLOTTED	BY
AREAS CHECKED	DATE	

ORIGINAL SURVEY	SURVEYED	DATE
NOTE BOOK NO.	PLOTTED	BY
AREAS CHECKED	DATE	

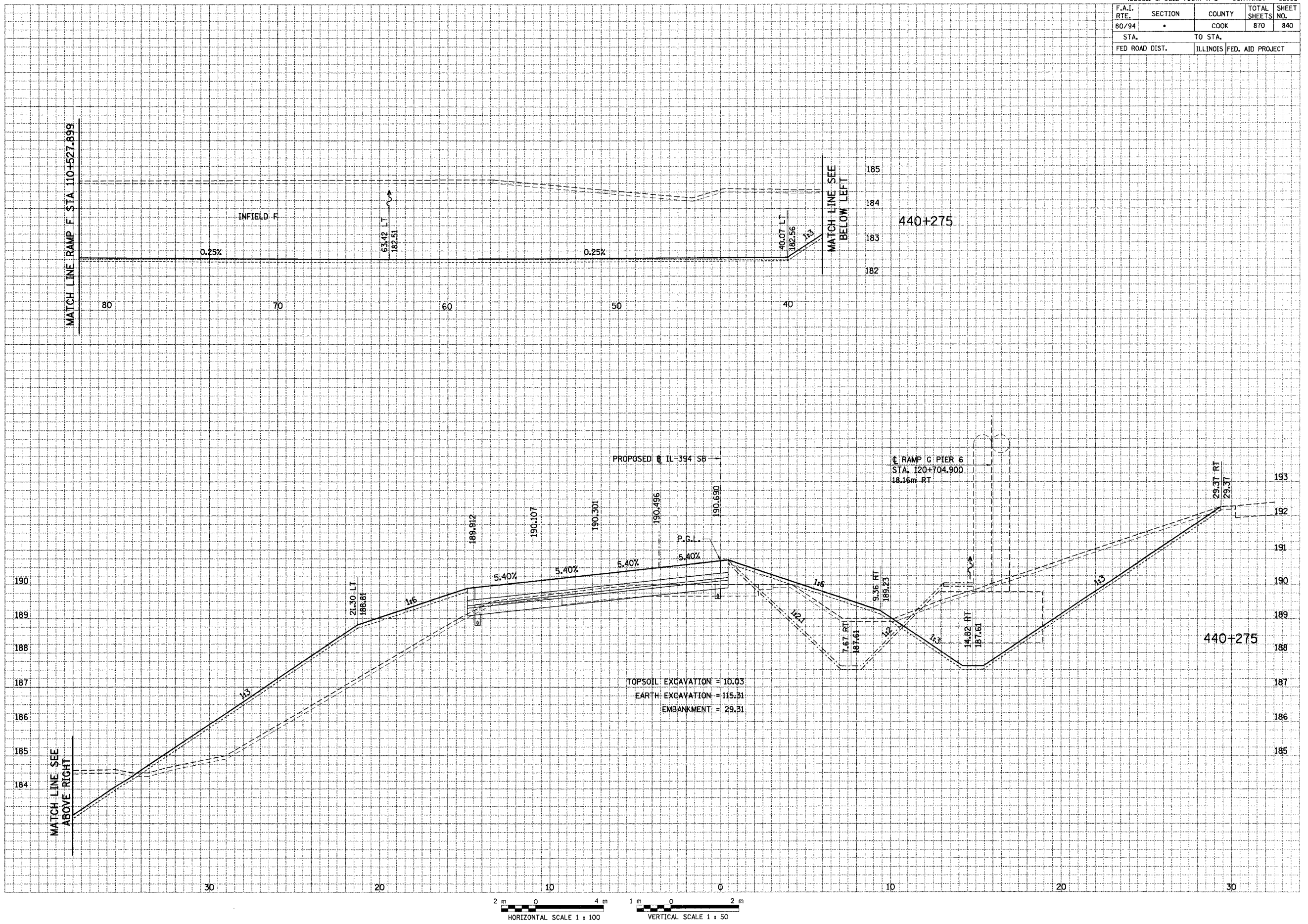



• (0203.1 & 0312-708W) R-3 CONTRACT # 62108			
F.A.I. RTE.	SECTION	COUNTY	TOTAL SHEETS
80/94	*	COOK	870
STA.	TO STA.		SHEET NO.
FED ROAD DIST.	ILLINOIS FED. AID PROJECT		840 A

FINAL SURVEY	DATE
SURVEY	BY
PLOTTED	
NOTE BOOK	
AREAS CHECKED	
NO.	

ORIGINAL SURVEY	DATE
SURVEY	BY
PLOTTED	
NOTE BOOK	
AREAS CHECKED	
NO.	

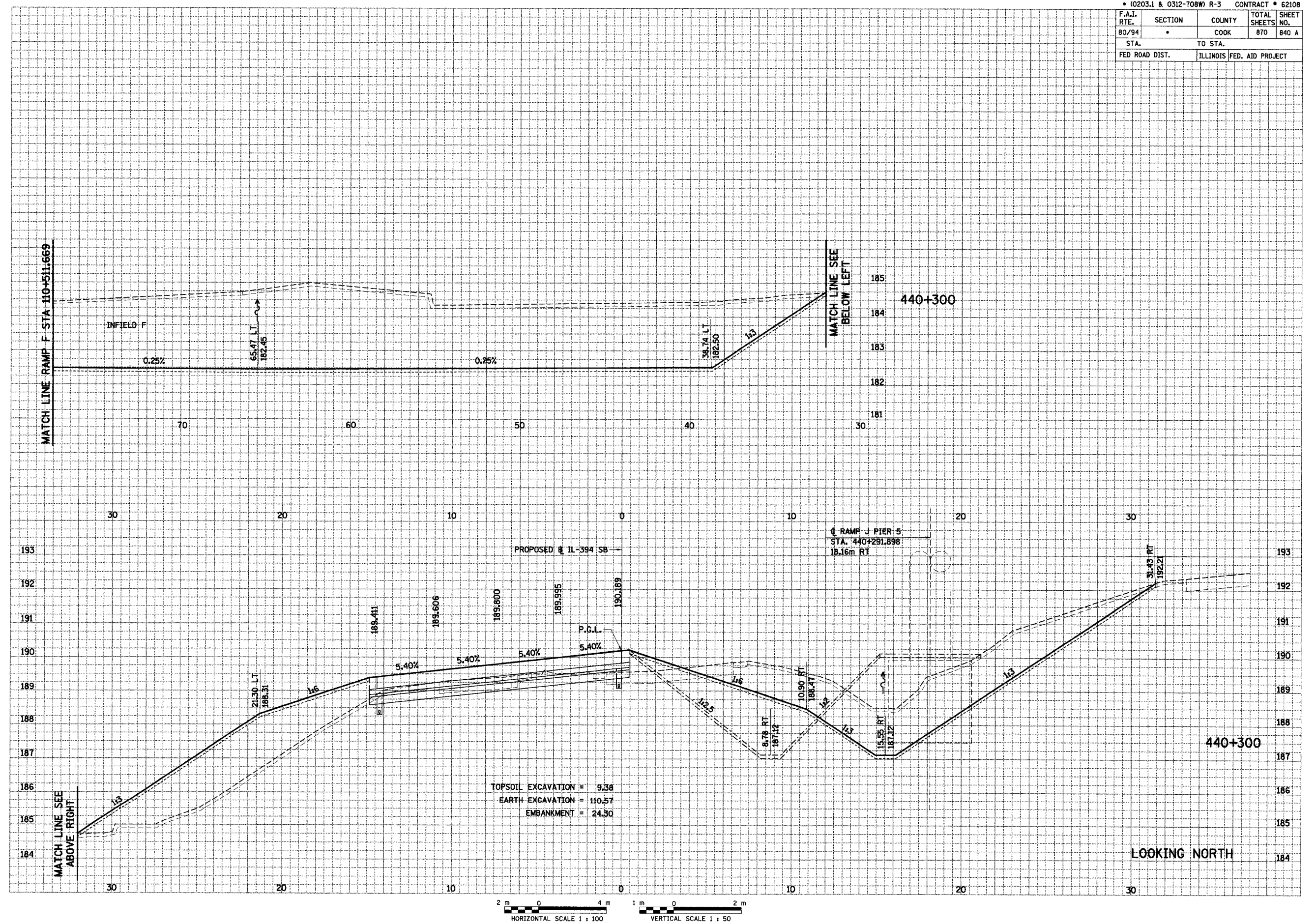

• (0203.1 & 0312-708W) R-3 CONTRACT # 62108

F.A.I. RTE.	SECTION	COUNTY	TOTAL SHEETS	SHEET NO.
80/94	•	COOK	870	841
STA.		TO STA.		
FED ROAD DIST.		ILLINOIS FED. AID PROJECT		

FINAL SURVEY	SURVEYED	DATE
NOTE BOOK NO.	PLOTTED	
NO.	AREAS	
	CHECKED	

ORIGINAL SURVEY	SURVEYED	DATE
NOTE BOOK NO.	PLOTTED	
NO.	AREAS	
	CHECKED	

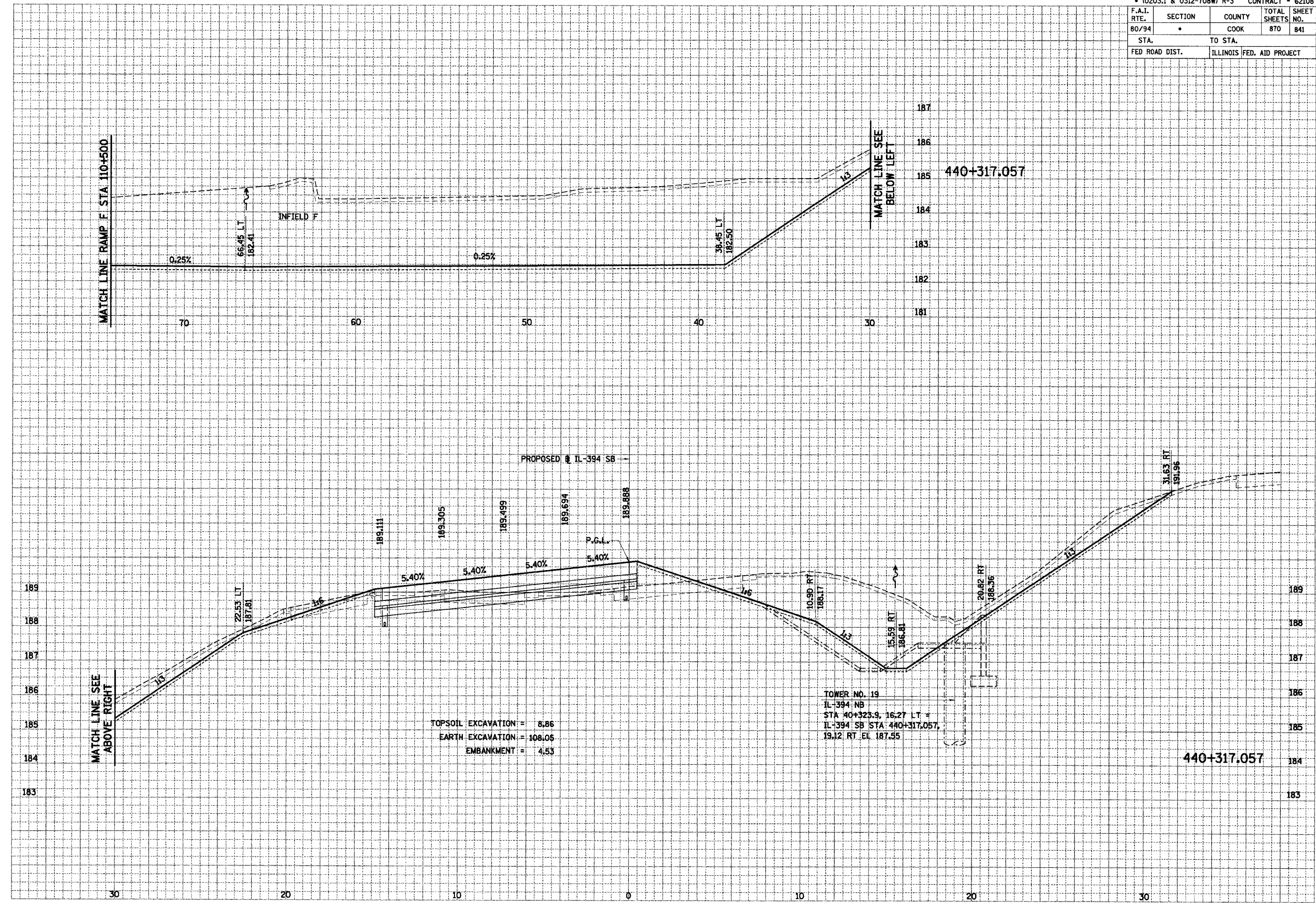





• (0203.1 & 0312-708W) R-3 CONTRACT • 62108

F.A.I. RTE.	SECTION	COUNTY	TOTAL SHEETS	SHEET NO.
80/94	*	COOK	870	843
STA.		TO STA.		
FED ROAD DIST.		ILLINOIS FED. AID PROJECT		

FINAL SURVEY	DATE
BY	
NOTED	
APPROVED	
CHECKED	

ORIGINAL SURVEY	DATE
BY	
NOTED	
APPROVED	
CHECKED	

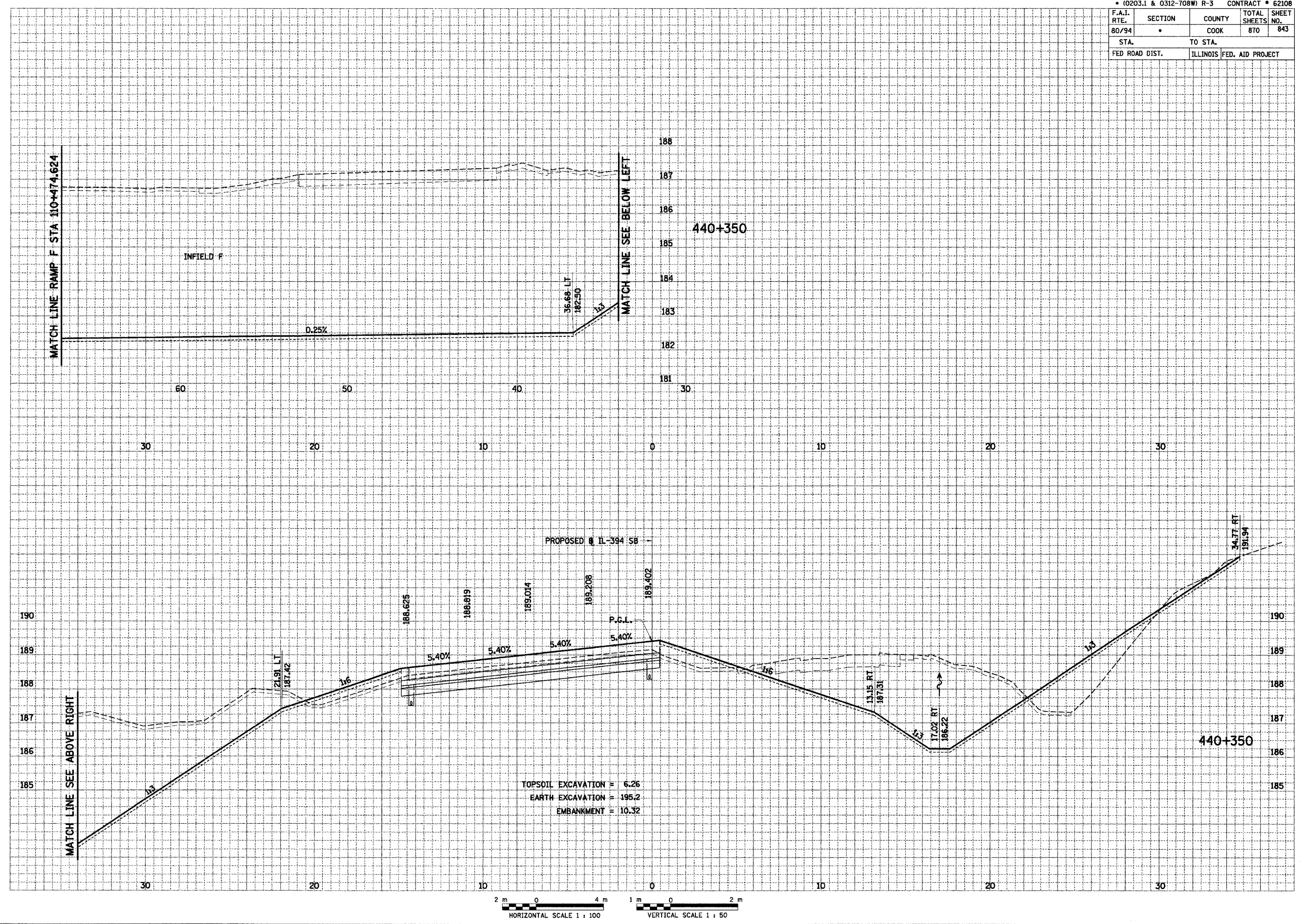



• (0203.1 & 0312-708W) R-3 CONTRACT • 62108				
F.A.I. RTE.	SECTION	COUNTY	TOTAL SHEETS	SHEET NO.
80/94	*	COOK	870	844
STA.		TO STA.		
FED ROAD DIST.		ILLINOIS FED. AID PROJECT		

FINAL SURVEY	DATE
REVISION	BY
NOTE BOOK	
AREAS CHECKED	

ORIGINAL SURVEY	DATE
REVISION	BY
NOTE BOOK	
AREAS CHECKED	

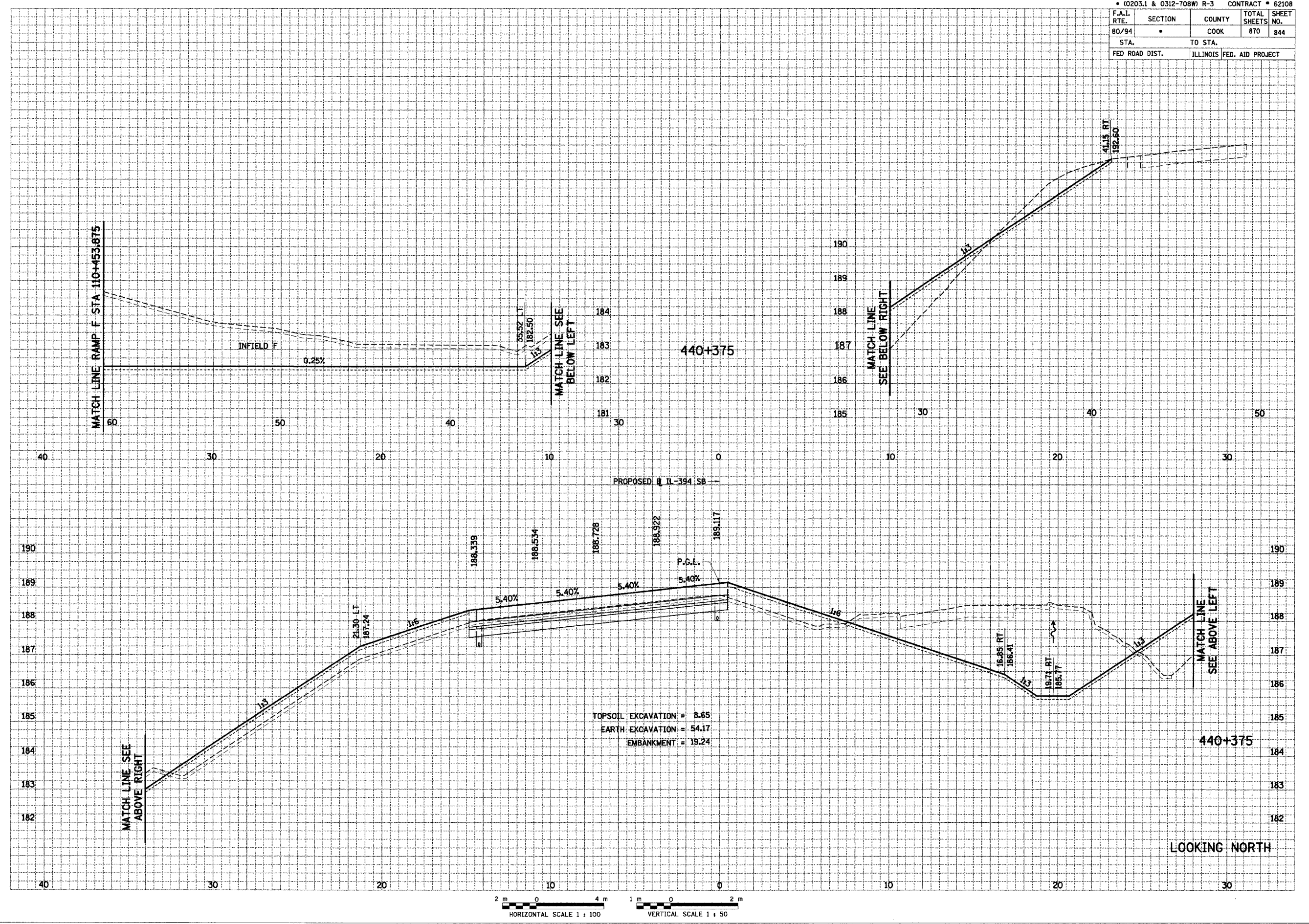





• (0203.1 & 0312-708W) R-3 CONTRACT • 62108				
F.A.I. RTE.	SECTION	COUNTY	TOTAL SHEETS	SHEET NO.
80/94	•	COOK	870	846
STA.		TO STA.		
FED ROAD DIST.		ILLINOIS FED. AID PROJECT		

FINAL SURVEY	DATE
BY	
SURVEYED	
PLOTTED	
NOTE BOOK	
AREAS CHECKED	
NO.	

ORIGINAL SURVEY	DATE
BY	
SURVEYED	
PLOTTED	
NOTE BOOK	
AREAS CHECKED	
NO.	

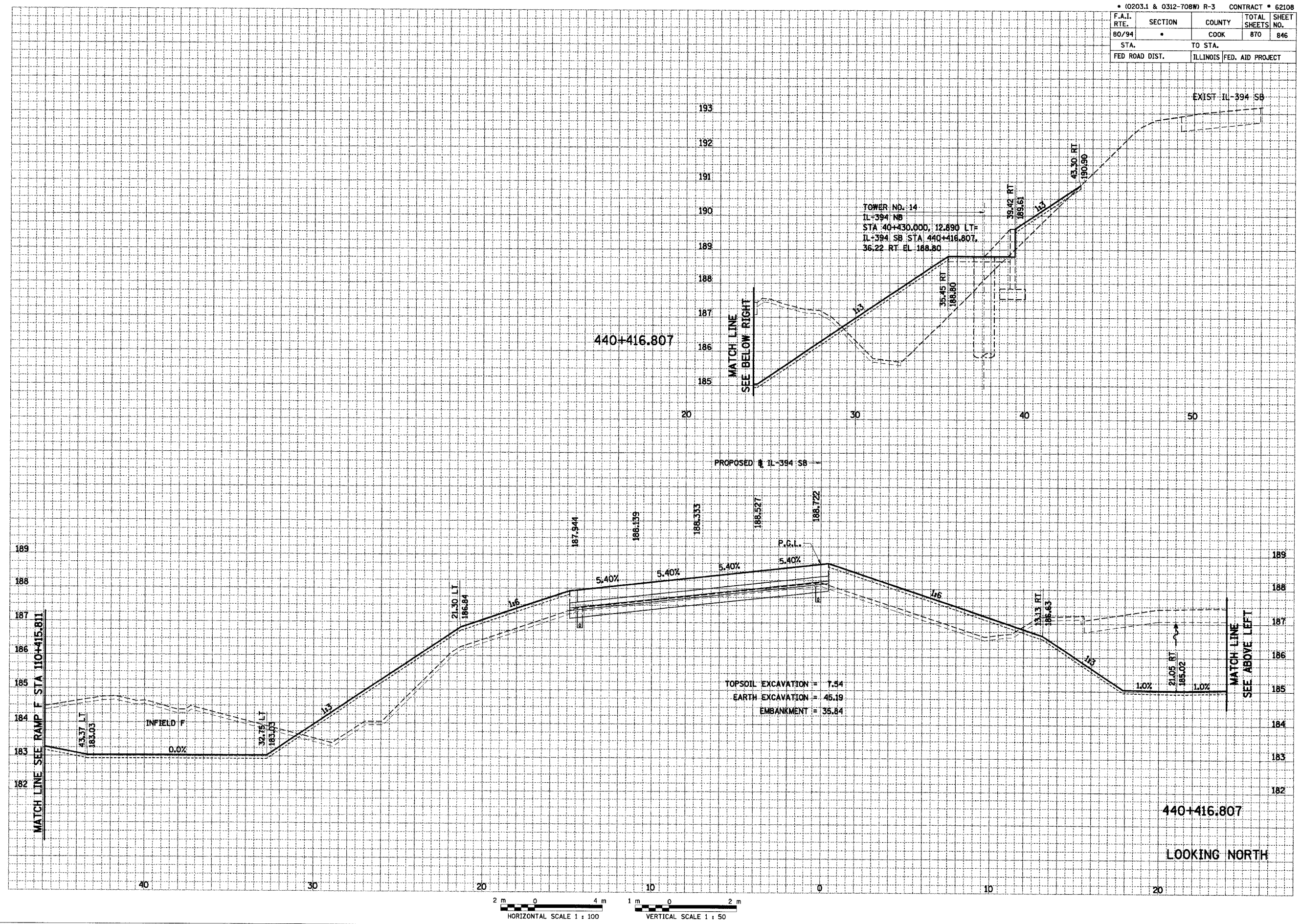

• (0203.1 & 0312-708W) R-3 CONTRACT • 62108				
F.A.I. RTE.	SECTION	COUNTY	TOTAL SHEETS	SHEET NO.
80/94	•	COOK	870	847
STA.		TO STA.		
FED ROAD DIST.		ILLINOIS FED. AID PROJECT		

FINAL SURVEY	SURVEYED	DATE
NOTE BOOK	NO.	
AREAS CHECKED		

ORIGINAL SURVEY	SURVEYED	DATE
NOTE BOOK	NO.	
AREAS CHECKED		

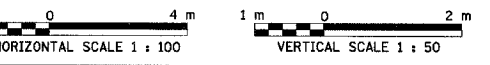
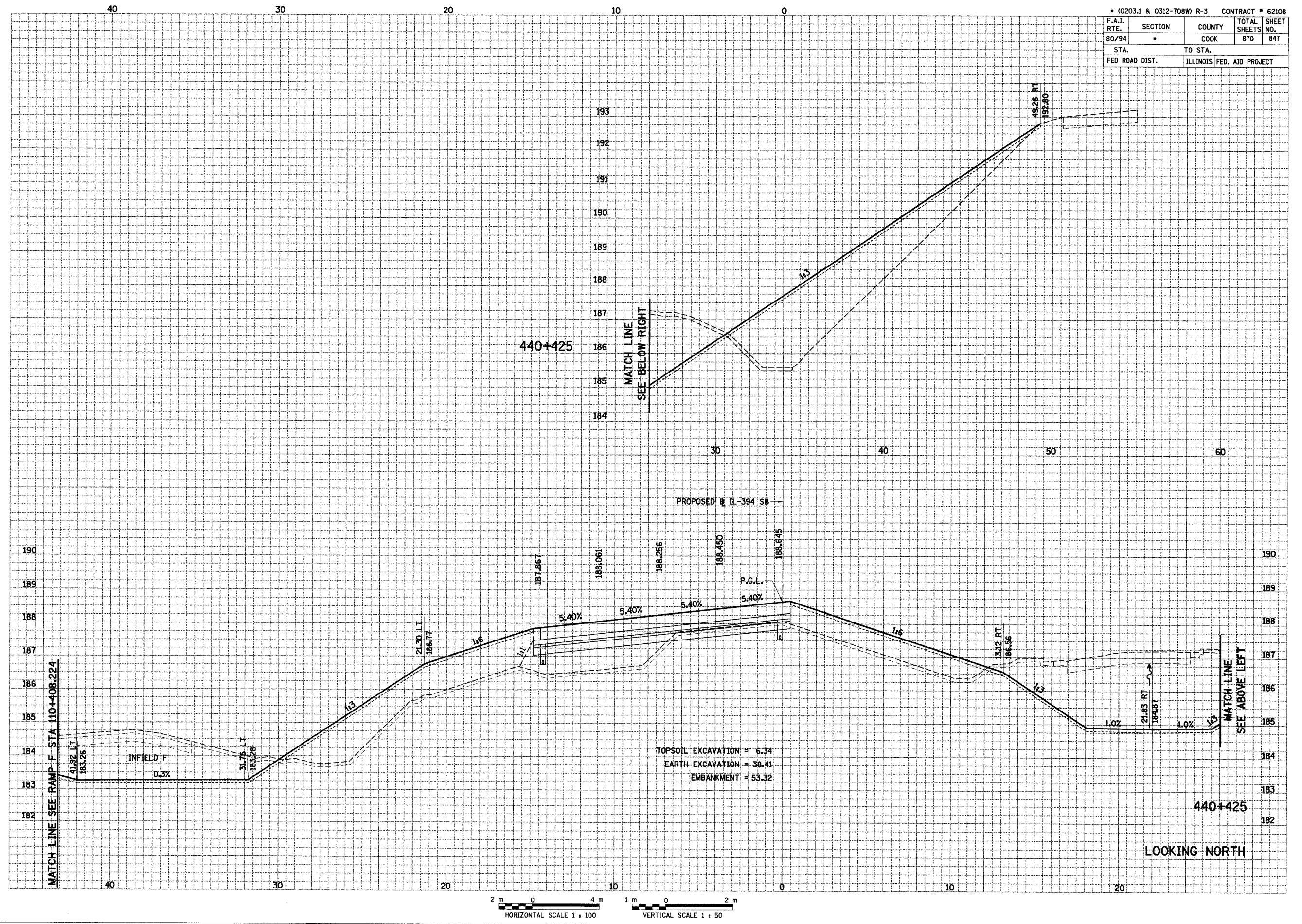





• (0203.1 & 0312-708W) R-3 CONTRACT • 62108			
F.A.I. RTE.	SECTION	COUNTY	TOTAL SHEETS NO.
80/94	*	COOK	870 849
STA.		TO STA.	
FED ROAD DIST.		ILLINOIS FED. AID PROJECT	

FINAL SURVEY	BY	DATE
NOTE BOOK		
AREAS CHECKED		

ORIGINAL SURVEY	BY	DATE
NOTE BOOK		
AREAS CHECKED		

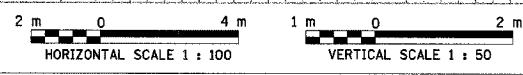
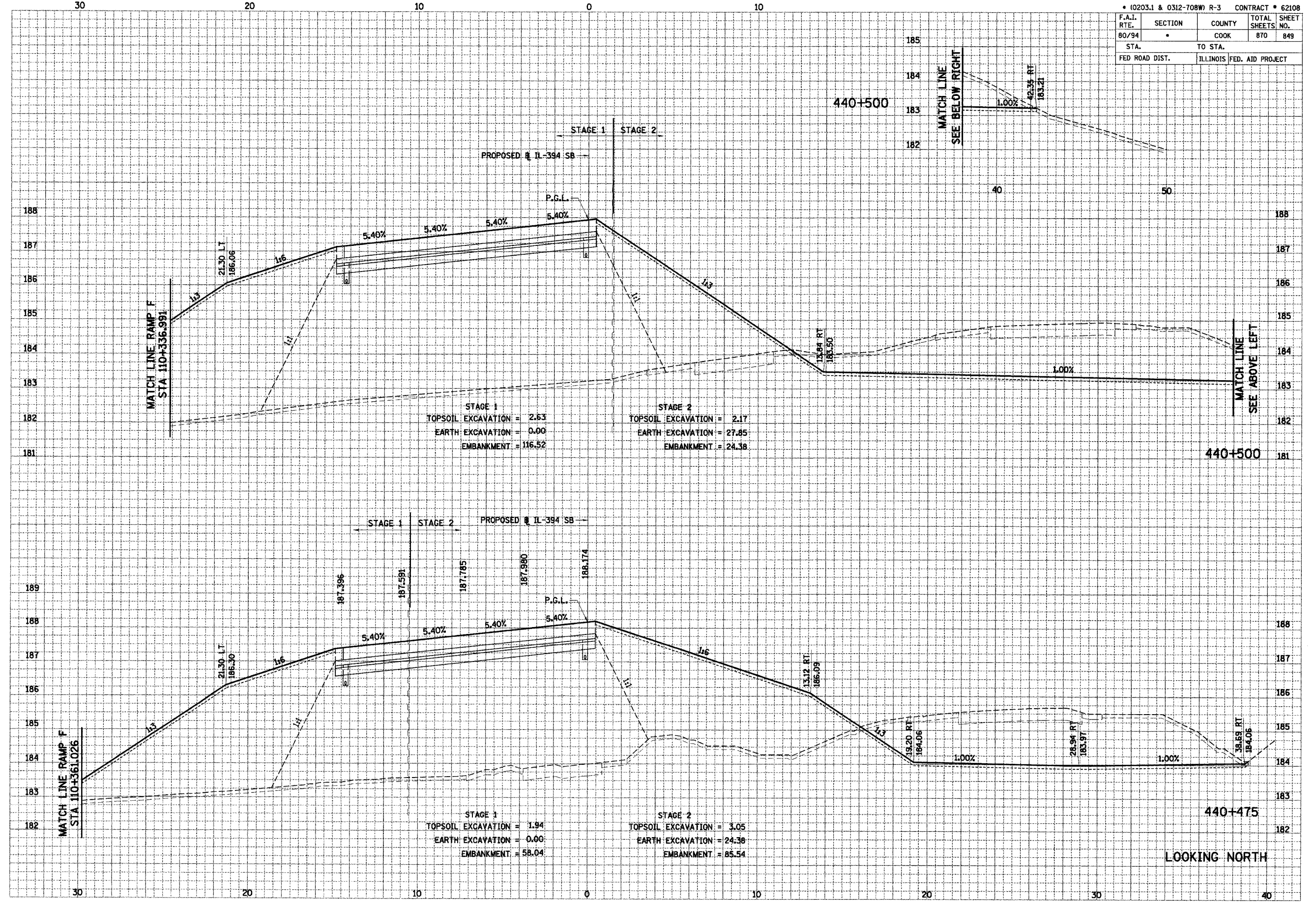



• (0203.1 & 0312-708W) R-3 CONTRACT # 62108

F.A.I. RTE.	SECTION	COUNTY	TOTAL SHEET NO.	
80/94	*	COOK	870	880
STA.		TO STA.		
FED ROAD DIST.		ILLINOIS FED. AID PROJECT		

FINL	DATE
SURVEYED	
NOTE BOOK	
AREAS CHECKED	
NO.	

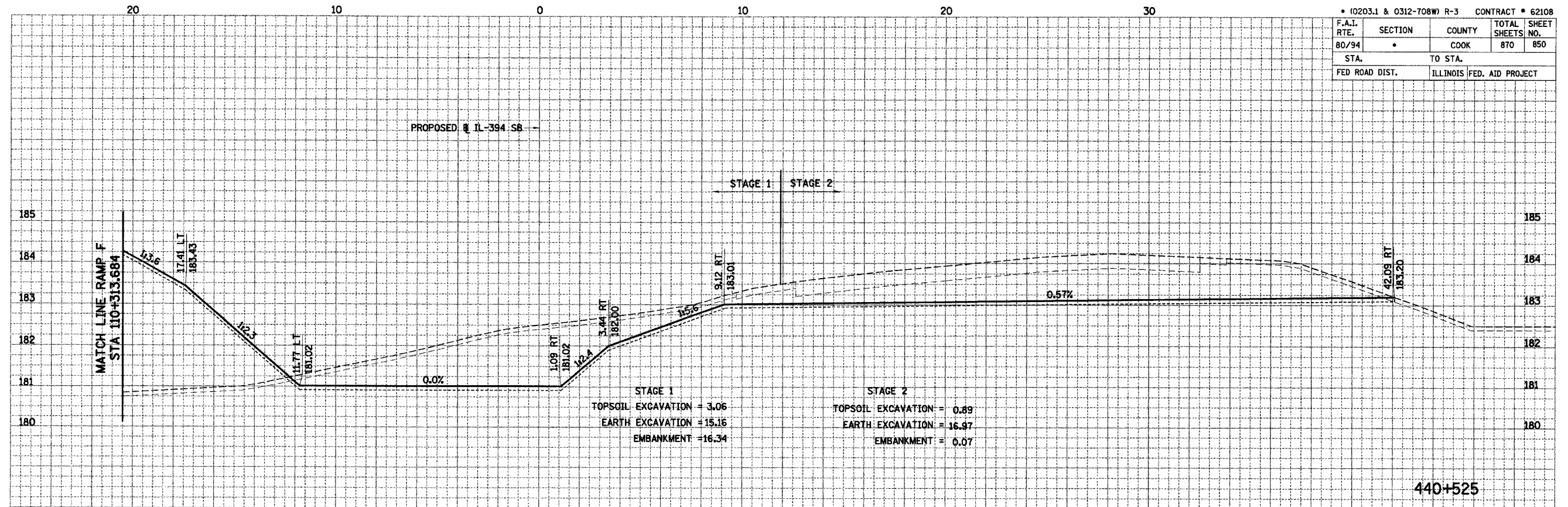

ORIGINAL	DATE
SURVEY	
NOTE BOOK	
AREAS CHECKED	
NO.	

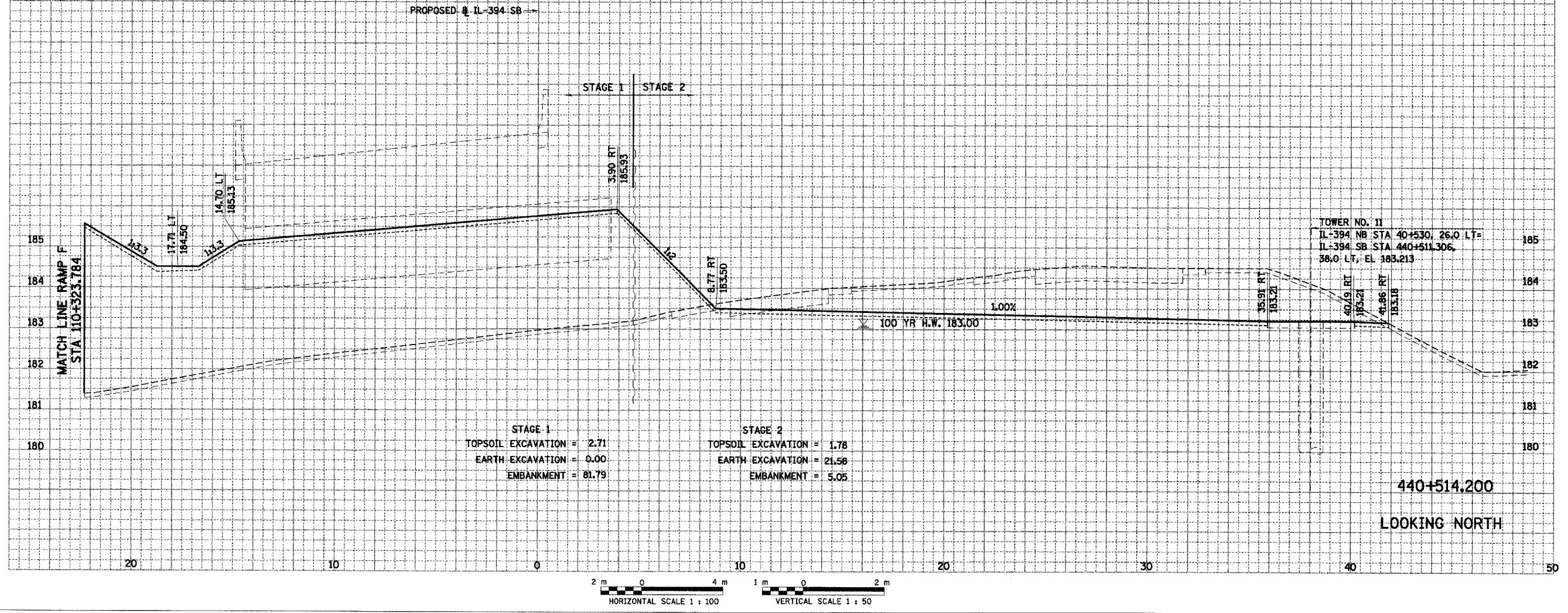

• (0203.1 & 0312-708W) R-3 CONTRACT # 62108				
F.A.I. RTE.	SECTION	COUNTY	TOTAL SHEETS	SHEET NO.
80/94	*	COOK	870	851
STA.		TO STA.		
FED ROAD DIST.		ILLINOIS FED. AID PROJECT		

FINAL SURVEY	SURVEYED	DATE
NOTE BOOK	BY	
NO.	AREAS CHECKED	

ORIGINAL SURVEY	SURVEYED	DATE
NOTE BOOK	BY	
NO.	AREAS CHECKED	

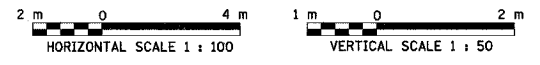
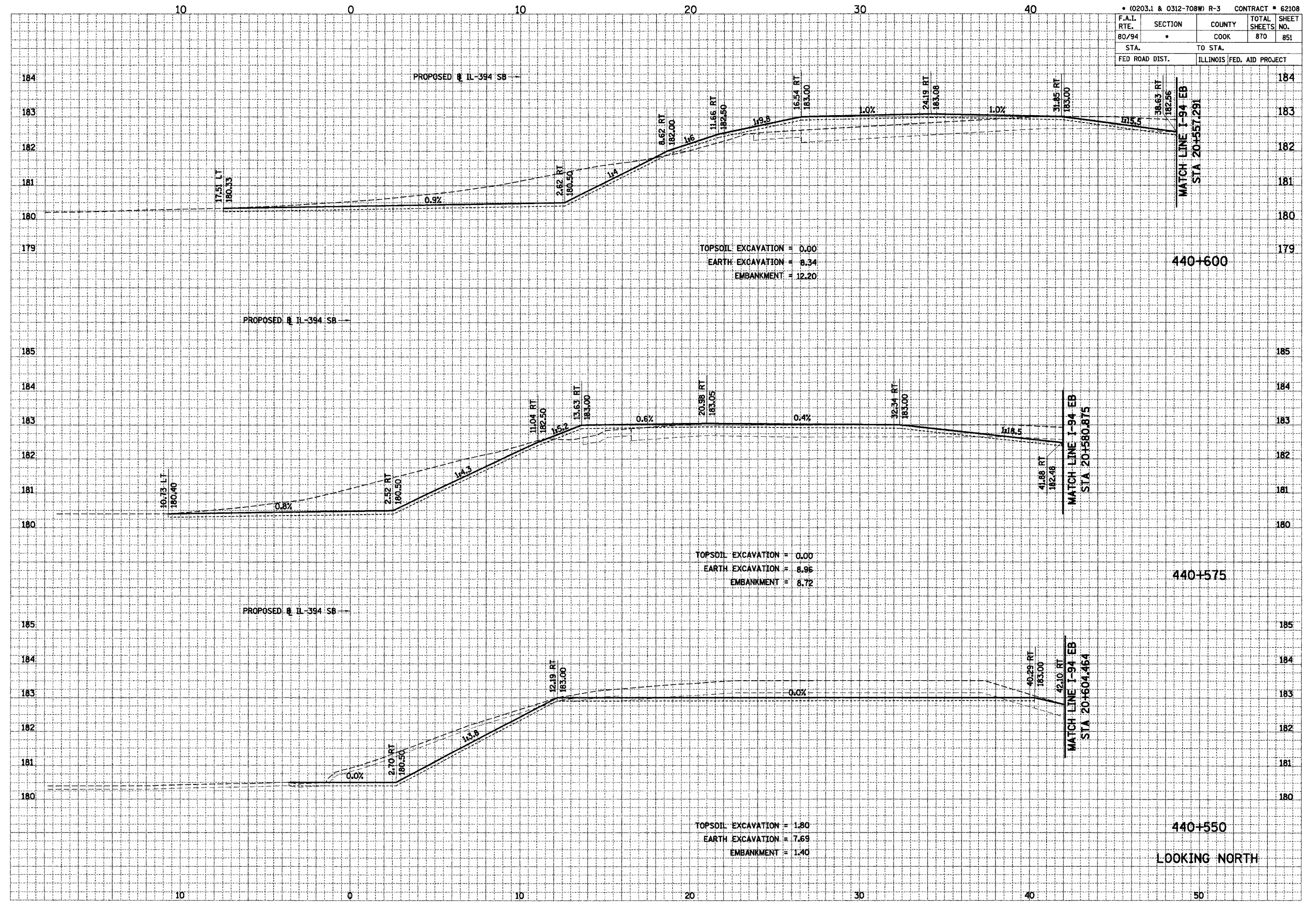



• (0203.1 & 0312-708W) R-3 CONTRACT # 62108			
F.A.I. RTE.	SECTION	COUNTY	TOTAL SHEETS
80/94	*	COOK	870
STA.		TO STA.	
FED ROAD DIST.		ILLINOIS FED. AID PROJECT	

FINAL SURVEY	DATE
NOTE BOOK	
AREAS CHECKED	

ORIGINAL SURVEY	DATE
NOTE BOOK	
AREAS CHECKED	

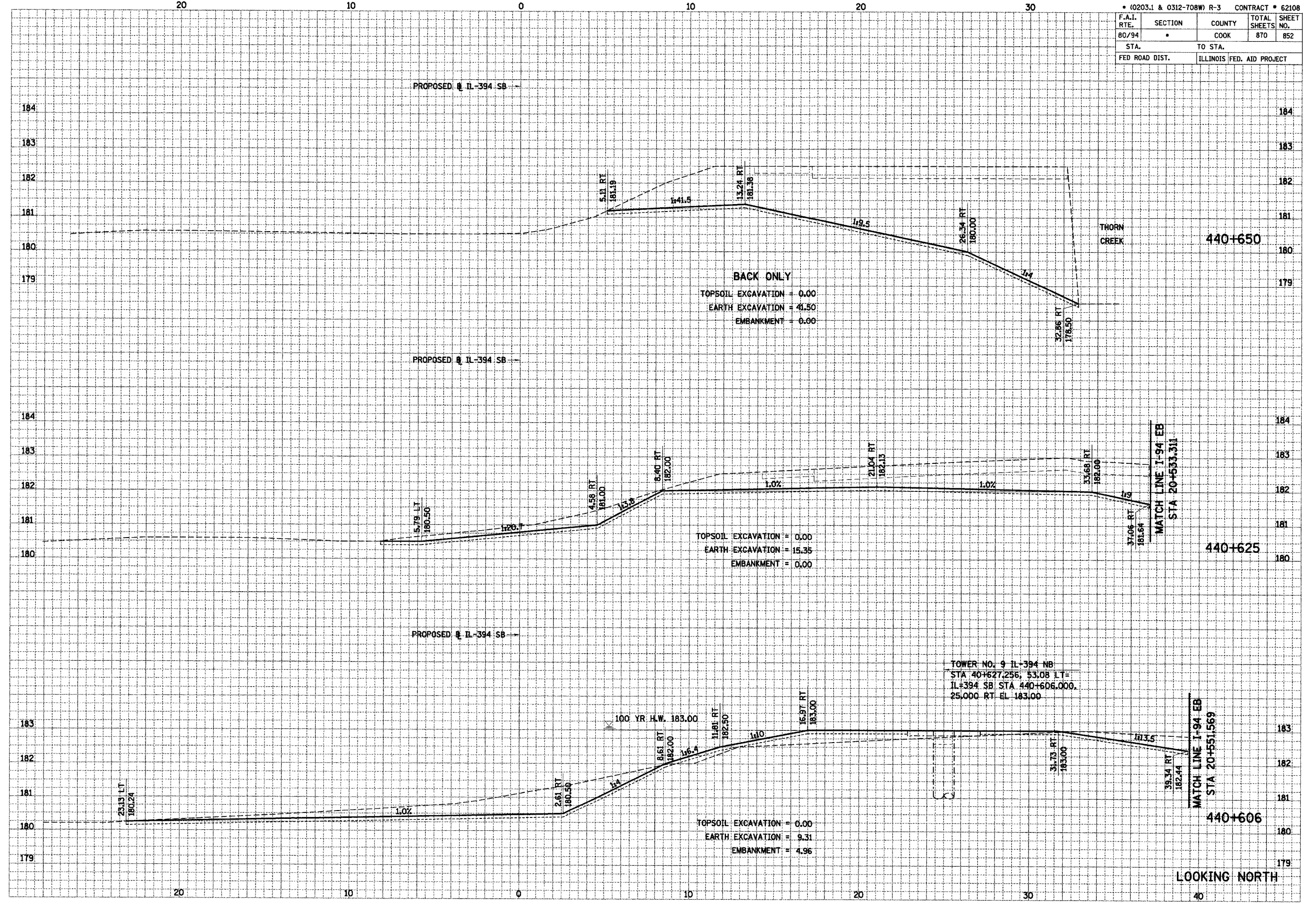







30 20 10 0 10 20 30

F.A.I. R-3		CONTRACT # 62108	
SECTION	COUNTY	TOTAL SHEETS	SHEET NO.
80/34	COOK	870	855
STA. TO STA.		FED. ROAD DIST. ILLINOIS FED. AID PROJECT	

DATE	BY
DATE	BY
DATE	BY
DATE	BY
DATE	BY

DATE	BY
DATE	BY
DATE	BY
DATE	BY
DATE	BY

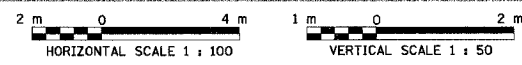
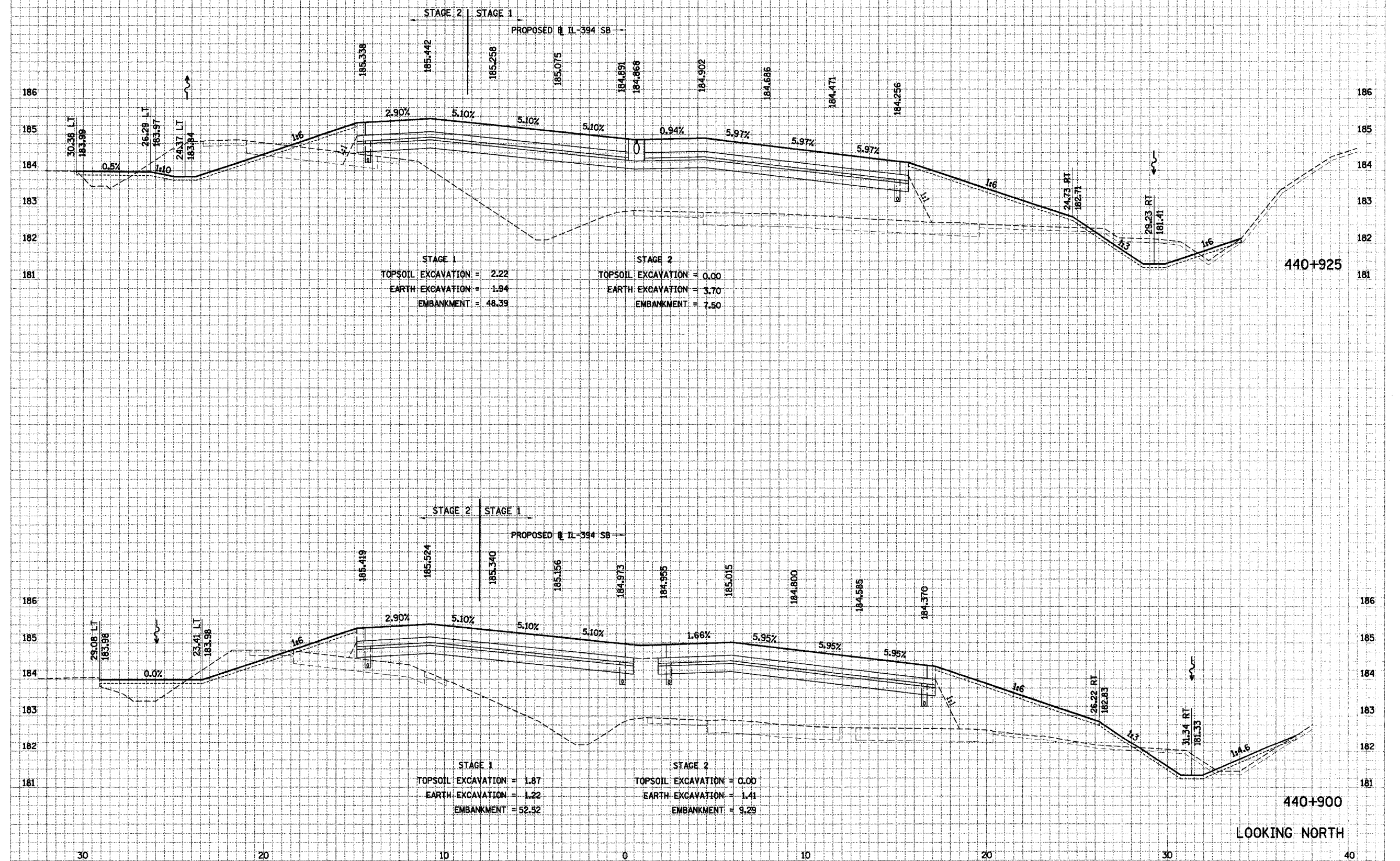









• (0203.1 & 0312-708W) R-3		CONTRACT # 62108	
F.A.I. RTE.	SECTION	COUNTY	TOTAL SHEETS NO.
80/94	*	COOK	870 858
STA. TO STA.		ILLINOIS FED. AID PROJECT	

DESIGNED BY	DATE
DRAWN BY	
CHECKED BY	
IN CHARGE BY	
APPROVED BY	
NO.	

DESIGNED BY	DATE
DRAWN BY	
CHECKED BY	
IN CHARGE BY	
APPROVED BY	
NO.	

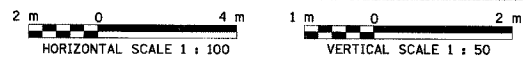
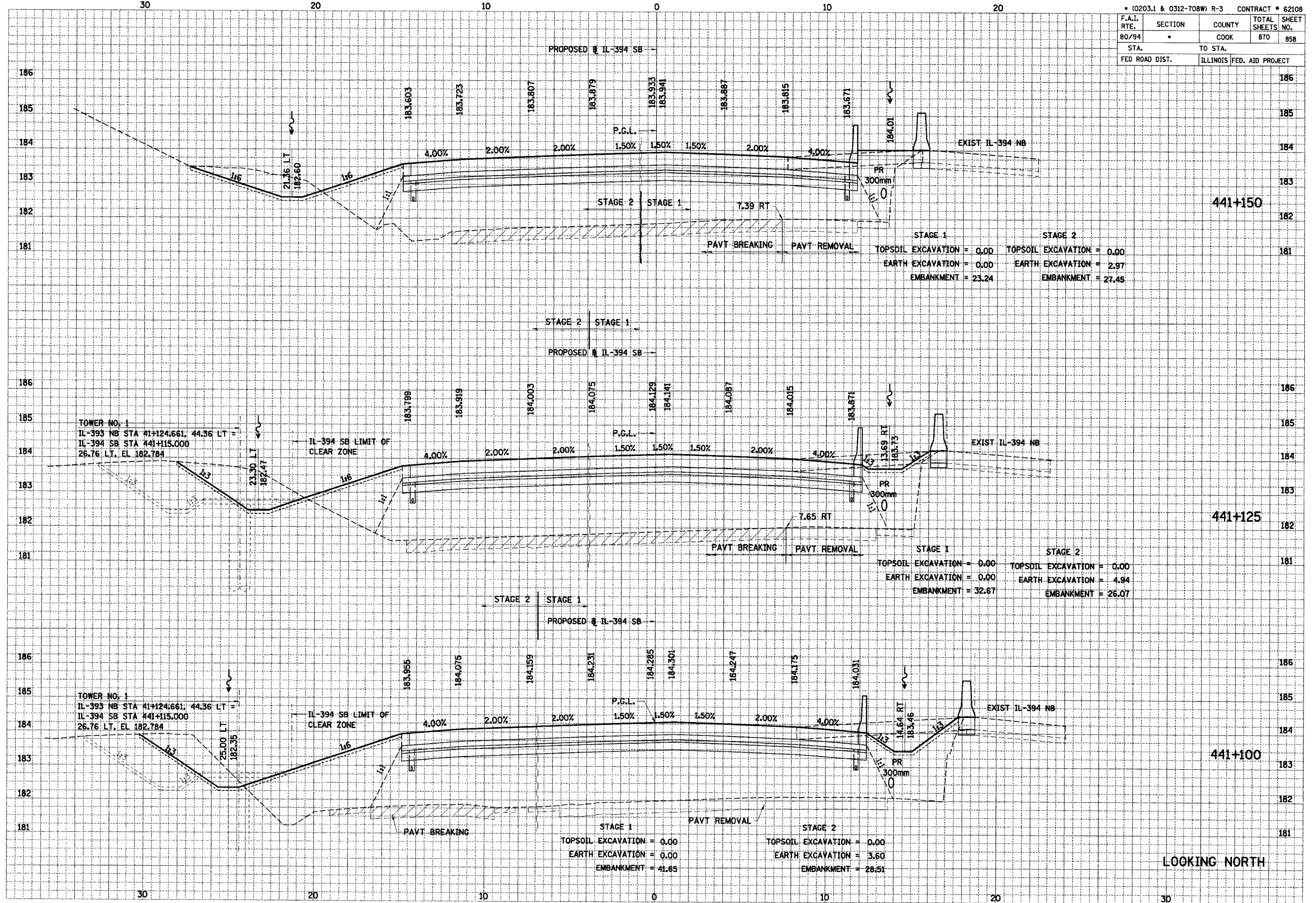

• (0203.1 & 0312-708W) R-3 CONTRACT # 62108				
F.A.I. RTE.	SECTION	COUNTY	TOTAL SHEETS	SHEET NO.
80/94	*	COOK	870	859
STA.		TO STA.		
FED ROAD DIST.		ILLINOIS FED. AID PROJECT		

FINAL SURVEY	SURVEYED	BY	DATE
NOTE BOOK	TEMPERATURE		
	AREAS CHECKED		
	NO.		

ORIGINAL SURVEY	SURVEYED	BY	DATE
NOTE BOOK	TEMPERATURE		
	AREAS CHECKED		
	NO.		

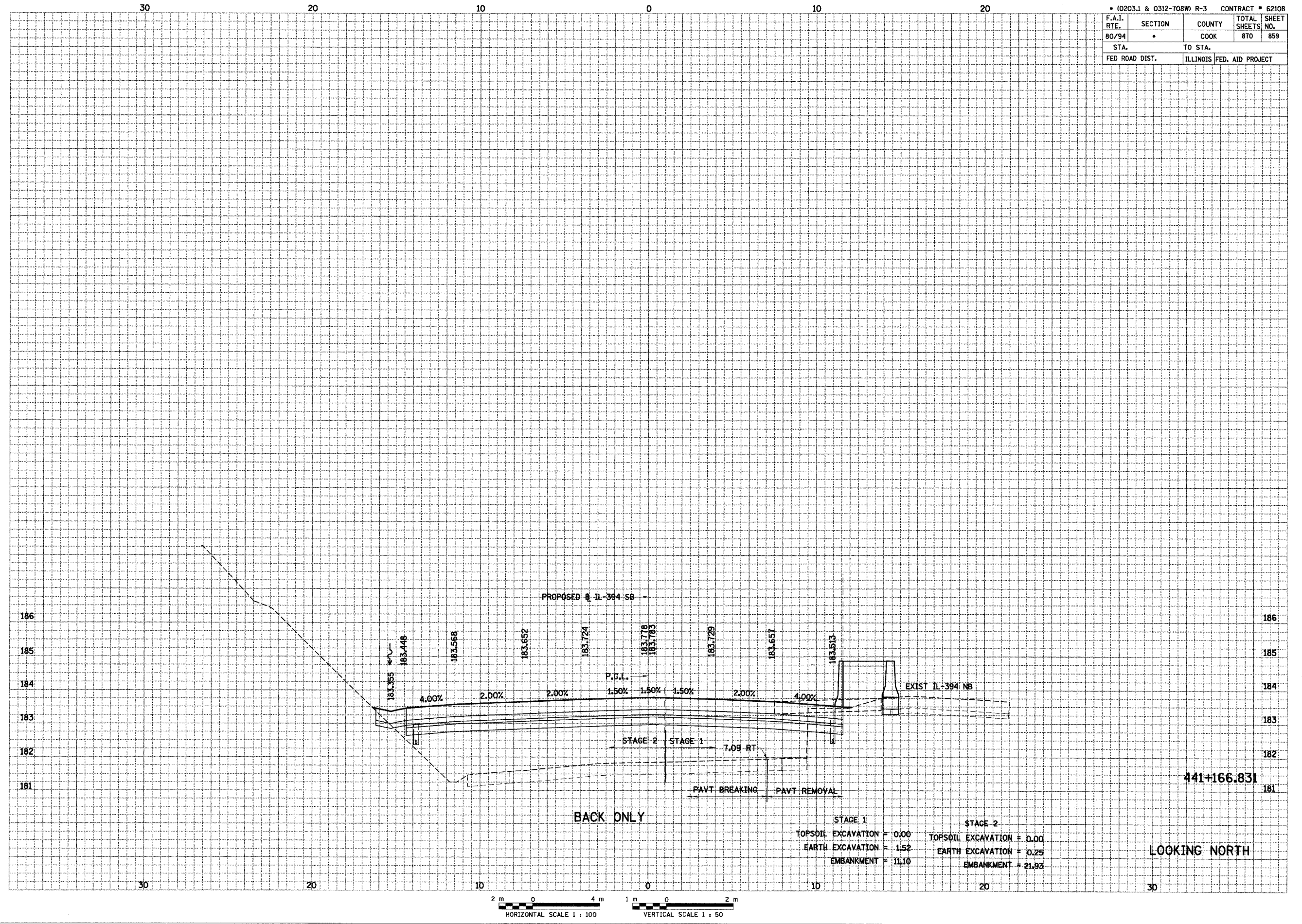

STAGE 1	STAGE 2
TOPSOIL EXCAVATION = 0.00	TOPSOIL EXCAVATION = 0.00
EARTH EXCAVATION = 1.52	EARTH EXCAVATION = 0.25
EMBANKMENT = 11.10	EMBANKMENT = 21.93

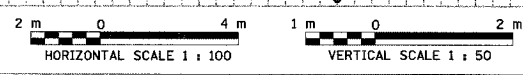



• (0203.1 & 0312-708W) R-3 CONTRACT • 62106

F.A.I. RTE.	SECTION	COUNTY	TOTAL SHEETS	SHEET NO.
80/94	•	COOK	870	860
STA. TO STA.		ILLINOIS FED. AID PROJECT		
181		180		
110+296		179		
181		20		

FINAL SURVEY	SURVEYED	BY	DATE
NO. _____	PLOTTED		
NO. _____	DATE		
NO. _____	AREAS CHECKED		

ORIGINAL SURVEY	SURVEYED	BY	DATE
NO. _____	PLOTTED		
NO. _____	DATE		
NO. _____	AREAS CHECKED		

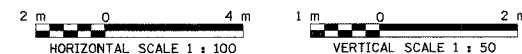
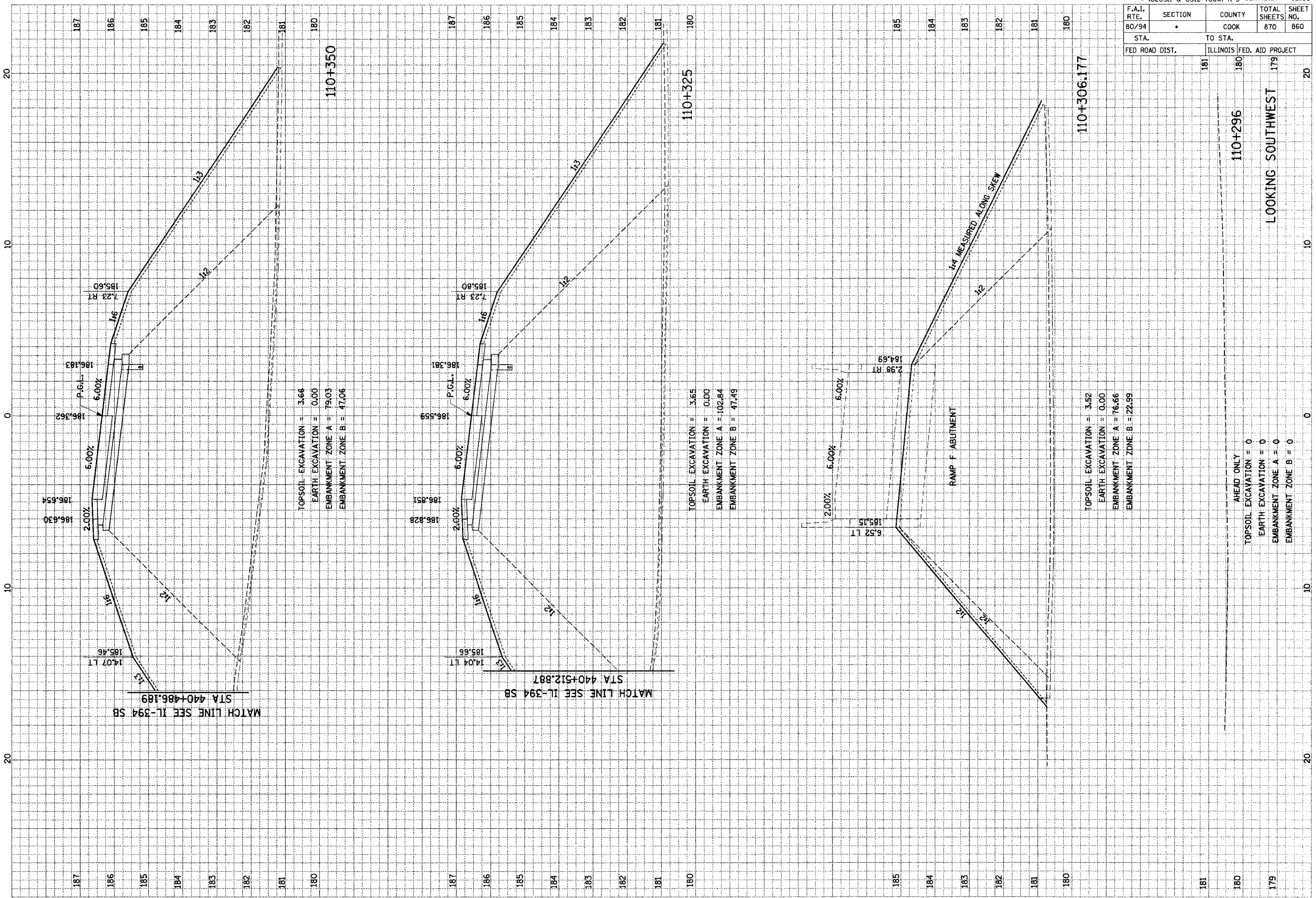





F.A.I. RTE.		SECTION	COUNTY	TOTAL SHEETS	SHEET NO.
80/94			COOK	870	862
STA.		TO STA.			
FED ROAD DIST.		ILLINOIS FED. AID PROJECT			

FINAL SURVEY	DATE
SURVEY	BY
NOTE BOOK	
AREAS	
CHECKED	

ORIGINAL SURVEY	DATE
SURVEY	BY
NOTE BOOK	
AREAS	
CHECKED	

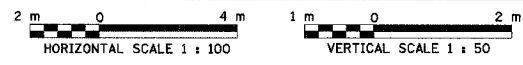
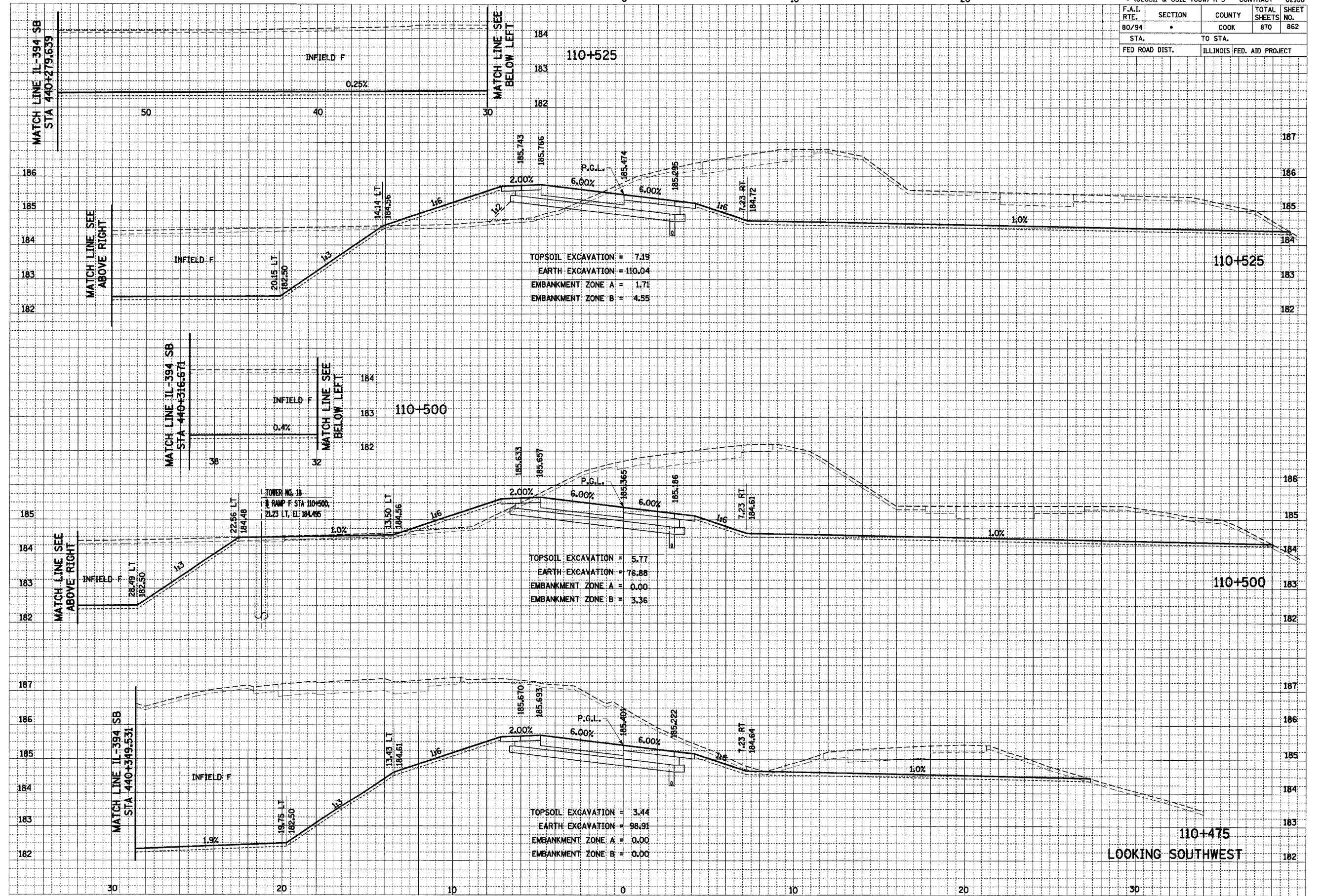

110-475  
LOOKING SOUTHWEST

RAMP F

• (0203.1 & 0312-708W) R-3 CONTRACT # 62108			
F.A.I. RTE.	SECTION	COUNTY	TOTAL SHEETS NO.
80/94	•	COOK	870 863
STA. TO STA.			
FED ROAD DIST.		ILLINOIS FED. AID PROJECT	

FINAL SURVEY	DATE
BY	
NO. OF SHEETS	
DATE	
BY	
NO. OF SHEETS	
DATE	
BY	
NO. OF SHEETS	

ORIGINAL SURVEY	DATE
BY	
NO. OF SHEETS	
DATE	
BY	
NO. OF SHEETS	
DATE	
BY	
NO. OF SHEETS	

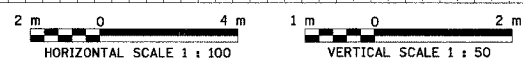
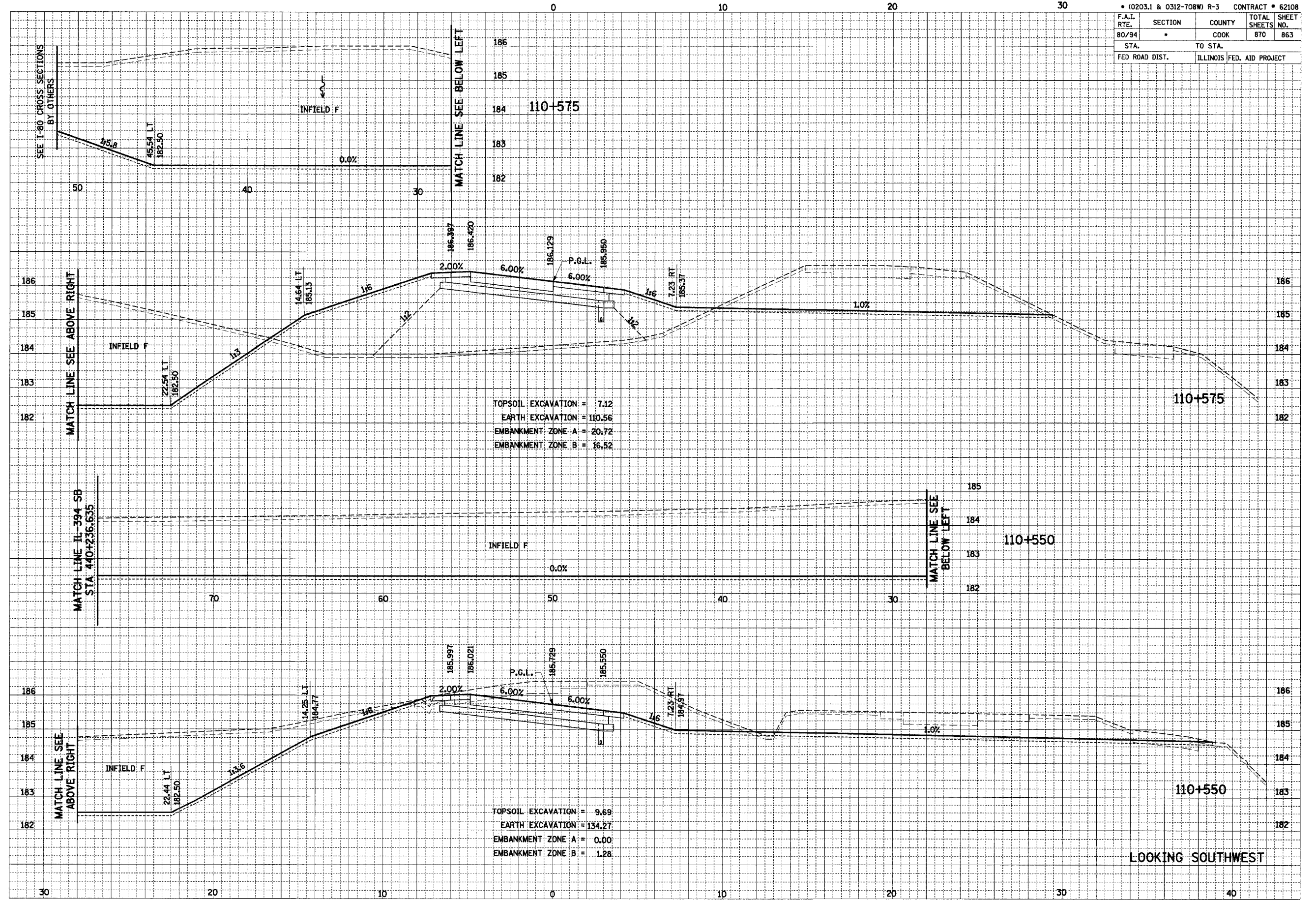

LOOKING SOUTHWEST

RAMP F









* (0203.1 & 0312-706W) R-3 CONTRACT * 62108			
F.A.I. RTE.	SECTION	COUNTY	TOTAL SHEETS
80/94		COOK	870
STA.	TO STA.		SHEET NO.
			866
FED ROAD DIST.		ILLINOIS FED. AID PROJECT	

FINAL SURVEY	BY	DATE
SURVEYED		
NOTE BOOK		
AREAS CHECKED		
NO.		

ORIGINAL SURVEY	BY	DATE
SURVEYED		
NOTE BOOK		
AREAS CHECKED		
NO.		

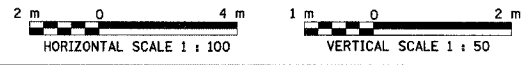
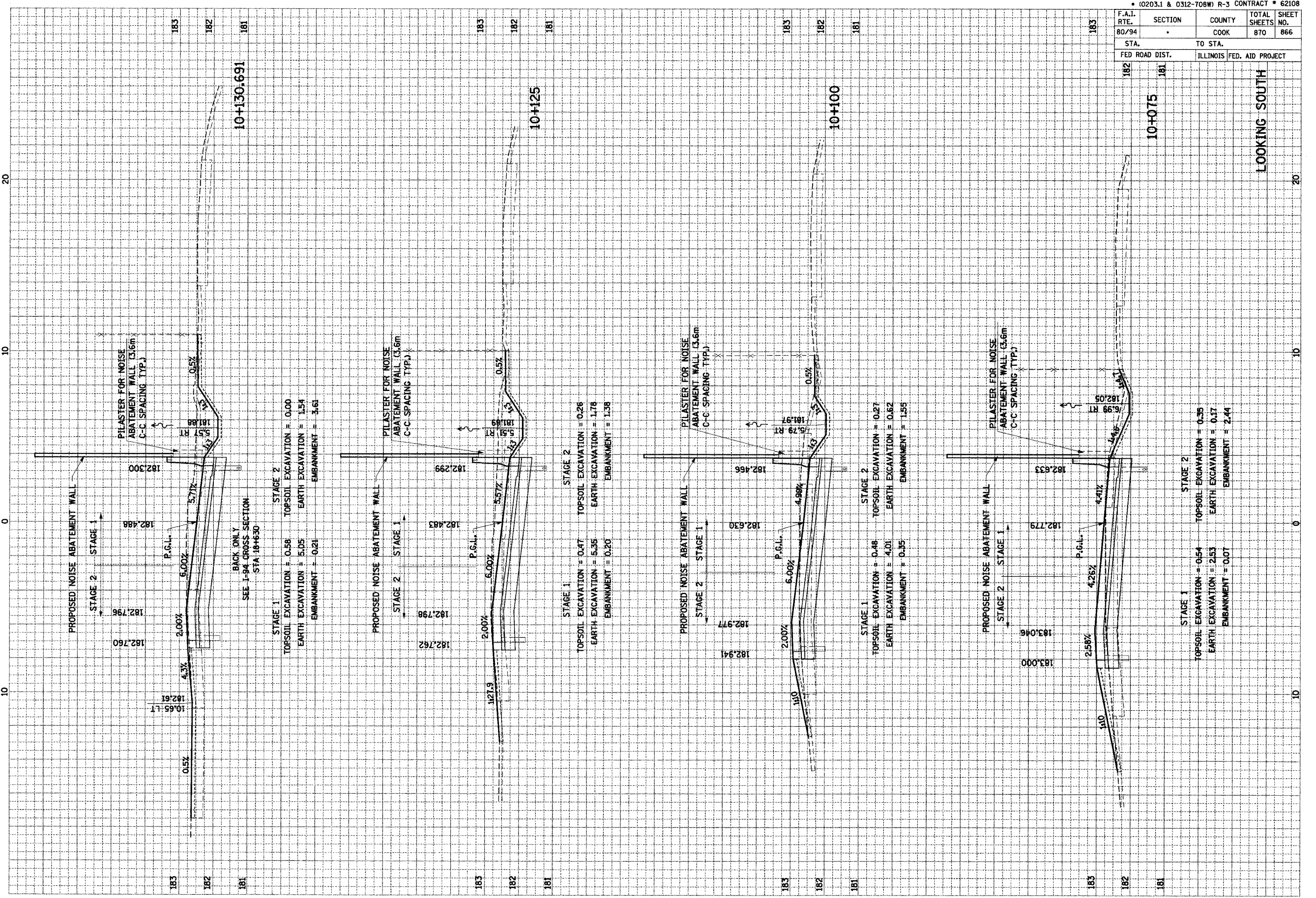

F.A.I. RTE.	SECTION	COUNTY	TOTAL SHEETS	SHEET NO.
80/94		COOK	870	867
STA.	TO STA.			
FED ROAD DIST.	ILLINOIS FED. AID PROJECT			
187	186	185	10+000	

FINAL SURVEY  
 DATE: \_\_\_\_\_ BY: \_\_\_\_\_  
 SURVEYED: \_\_\_\_\_  
 NOTE BOOK: \_\_\_\_\_  
 NO. \_\_\_\_\_  
 AREAS CHECKED: \_\_\_\_\_  
 (PLEASE CHECKED)

ORIGINAL SURVEY  
 DATE: \_\_\_\_\_ BY: \_\_\_\_\_  
 SURVEYED: \_\_\_\_\_  
 NOTE BOOK: \_\_\_\_\_  
 NO. \_\_\_\_\_  
 AREAS CHECKED: \_\_\_\_\_  
 (PLEASE CHECKED)

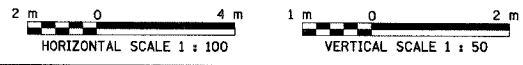
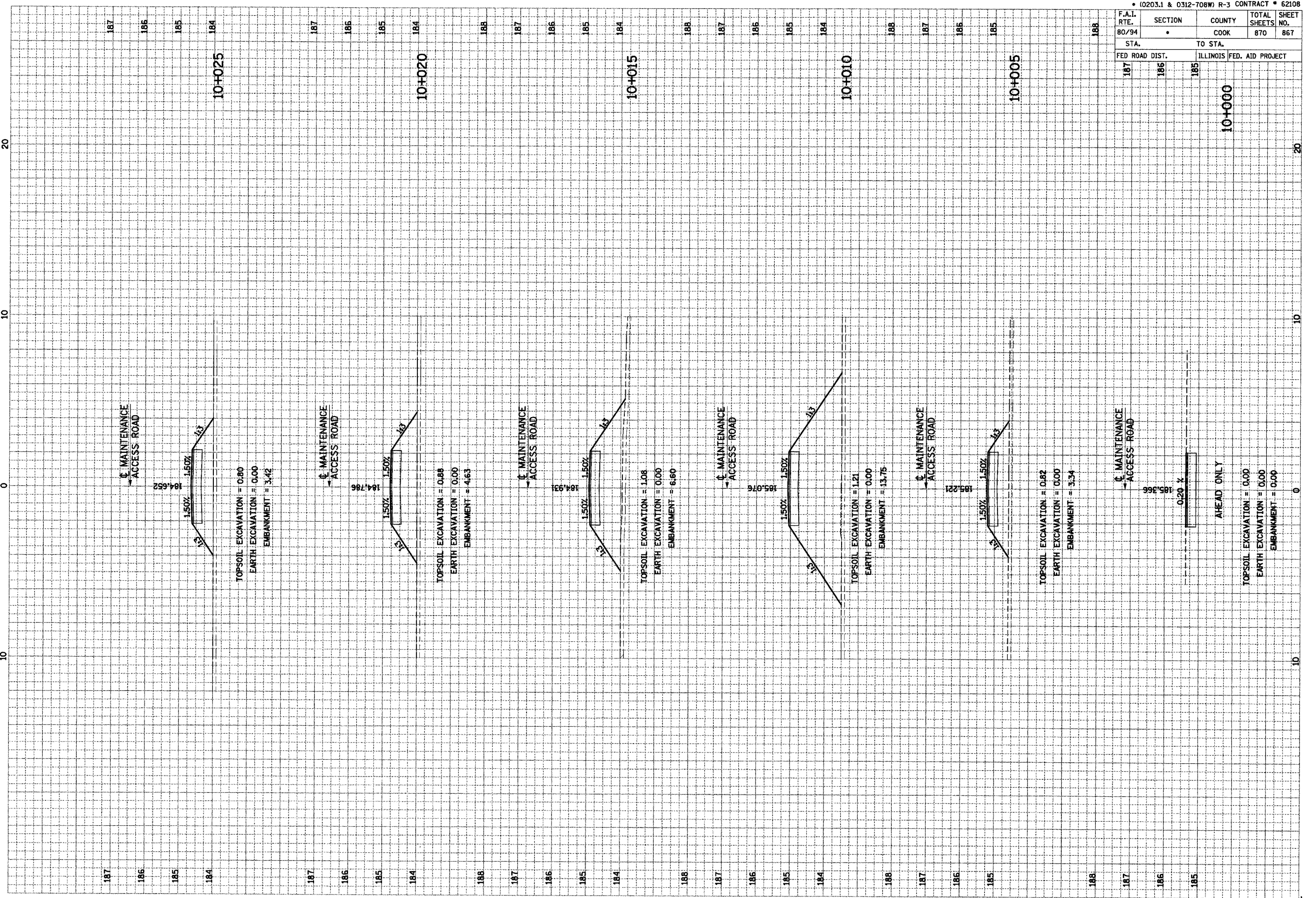



• (0203.1 & 0312-706W) R-3 CONTRACT • 62108

F.A.I. RTE.	SECTION	COUNTY	TOTAL SHEETS	SHEET NO.
80/94		COOK	870	868
STA.		TO STA.		
FED ROAD DIST.		ILLINOIS FED. AID PROJECT		
187	186	185	184	184

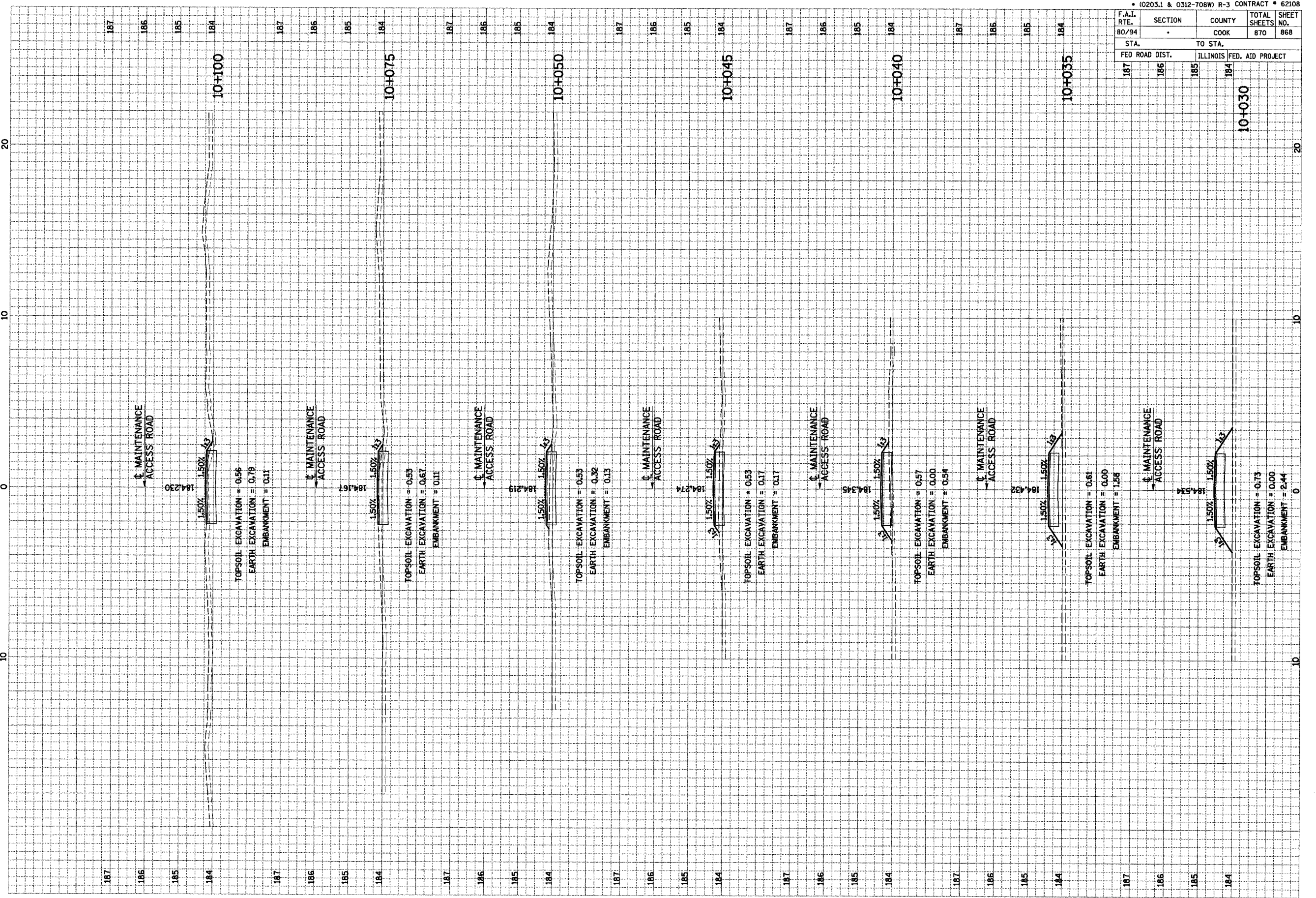

FINAL SURVEY	DATE
BY	
NO.	

ORIGINAL SURVEY	DATE
BY	
NO.	

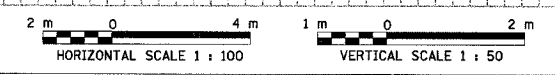

• (0203.1 & 0312-708W) R-3 CONTRACT # 62108

F.A.I. RTE.	SECTION	COUNTY	TOTAL SHEETS	SHEET NO.
80/94		COOK	870	869
STA. TO STA.		ILLINOIS FED. AID PROJECT		
187	186	185	184	183

FINAL SURVEY	DATE
NOTE BOOK	BY
AREAS CHECKED	

ORIGINAL SURVEY	DATE
NOTE BOOK	BY
AREAS CHECKED	

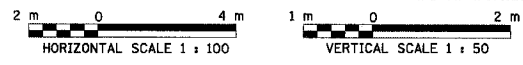
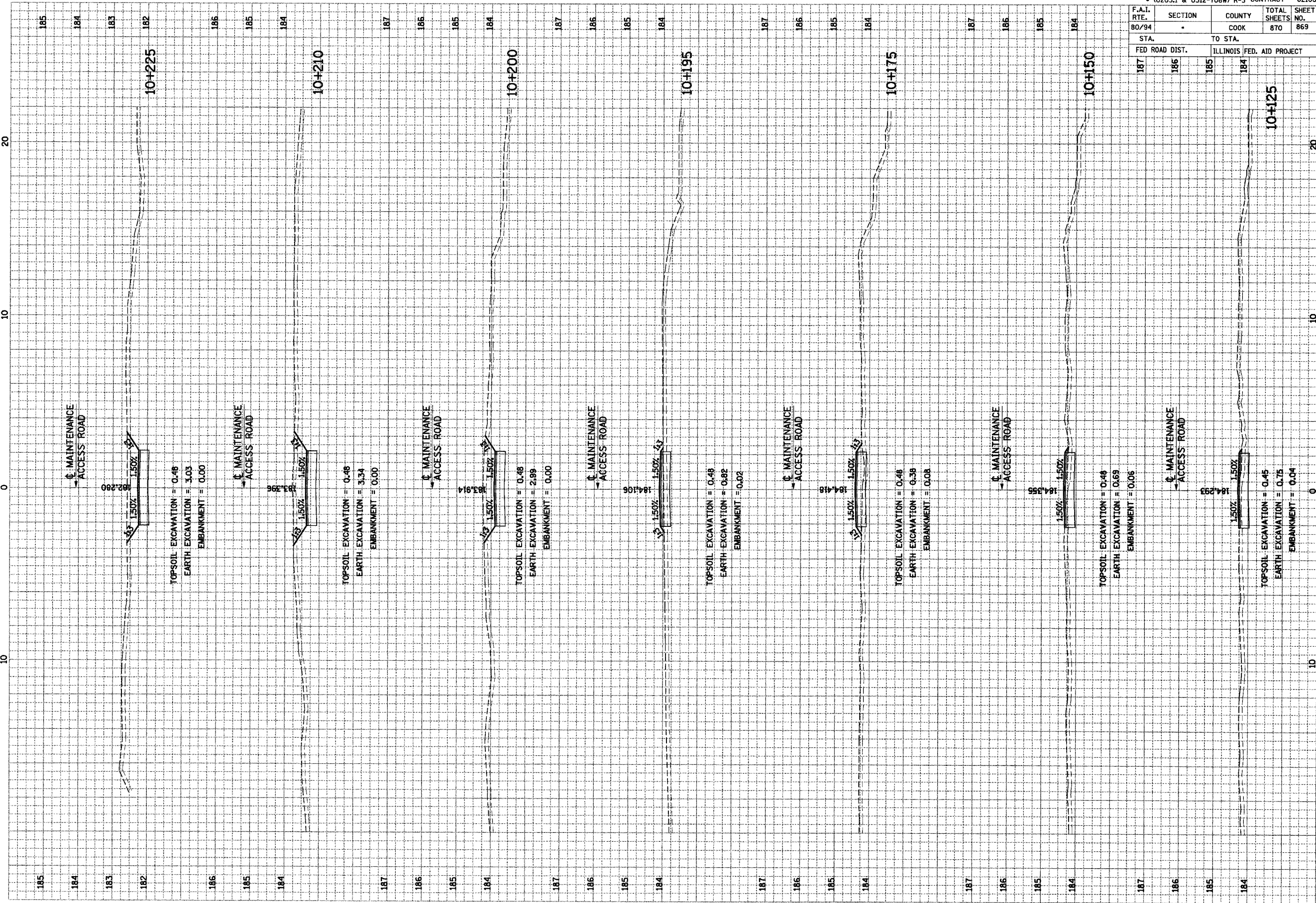



• (0203.1 & 0312-708W) R-3 CONTRACT # 62108

F.A.I. RTE.	SECTION	COUNTY	TOTAL SHEETS	SHEET NO.
80/94		COOK	870	870
STA.		TO STA.		
FED ROAD DIST.		ILLINOIS	FED. AID PROJECT	
183	182	181	180	179

FINAL SURVEY	SURVEYED	BY	DATE
NOTE BOOK	PLOTTED		
NO.	AREAS		
	CHECKED		

ORIGINAL SURVEY	SURVEYED	BY	DATE
NOTE BOOK	PLOTTED		
NO.	AREAS		
	CHECKED		

