

SECTION THRU BARRIER AT PILASTER

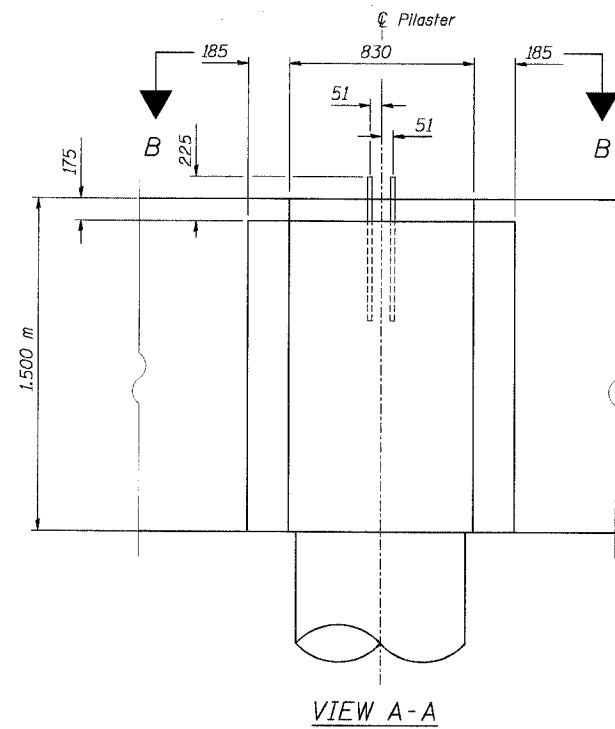

VIEW A-A

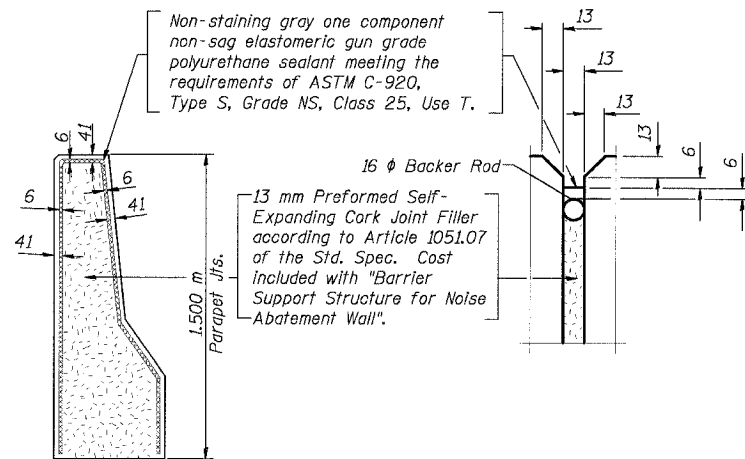
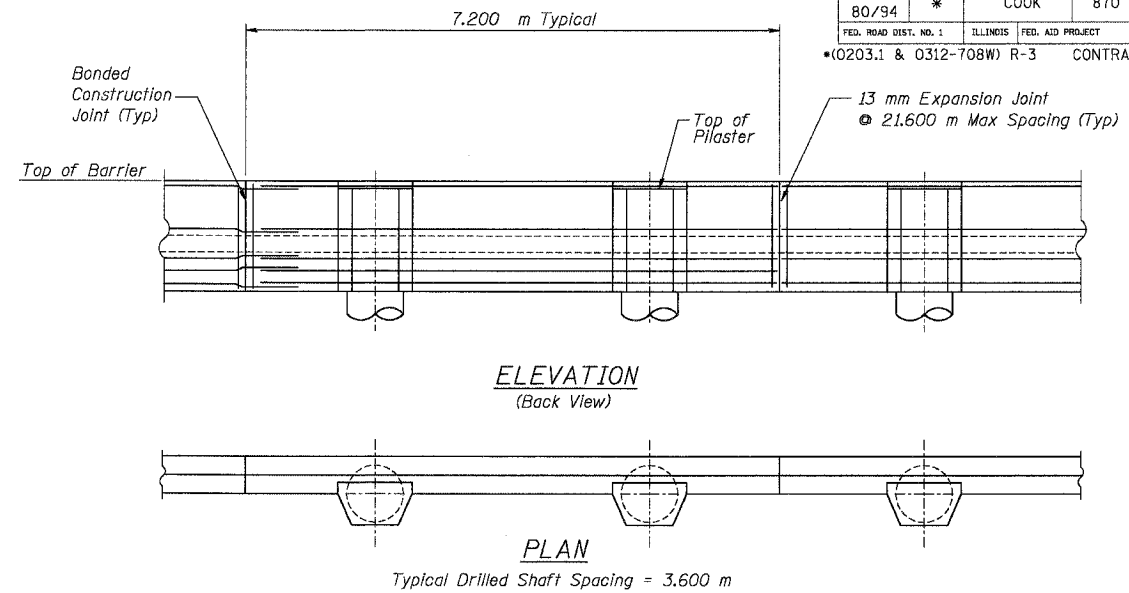

BARRIER EXPANSION JOINT DETAIL

Cast of joint sealant P.J.F. and cement nails are included with "Barrier Support Structure for Noise Abatement Wall"

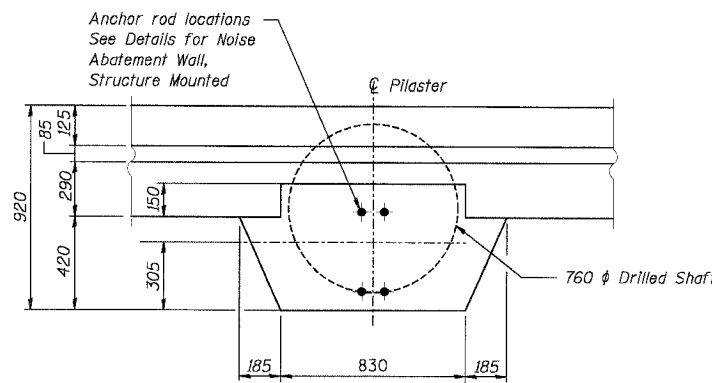

VIEW B-B

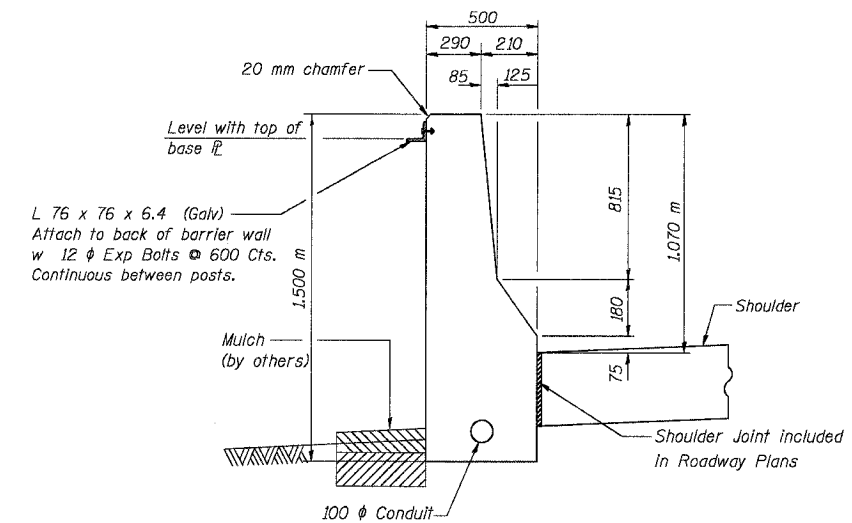

SECTION THRU BARRIER BETWEEN PILASTERS

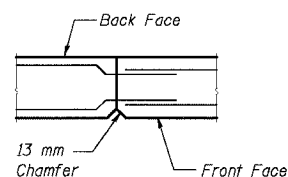

CONSTRUCTION JOINT DETAIL

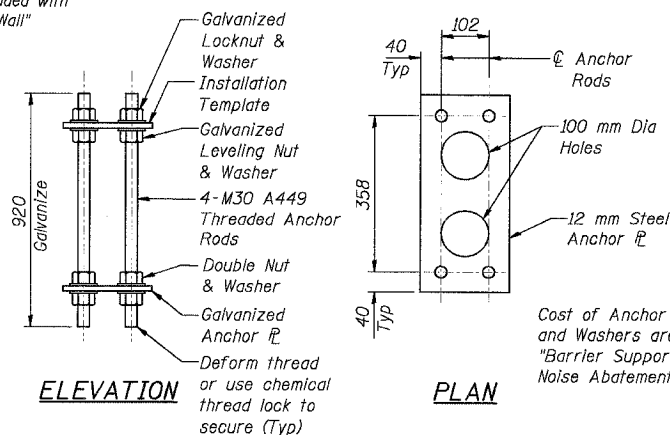

NOISE ABATEMENT WALL ANCHOR ROD ASSEMBLY

NOTES:

- B.F. indicates Back Face
- E.F. indicates Each Face
- Reinforcement bars shall conform to the requirements of AASHTO M31M, M42M, or M53M Grade 400
- All dimensions are in millimeters (mm) except as noted.
- Banded Construction Joint in accordance with Article 503.09 (b) of the Standard Specifications.
- All bars shall be epoxy coated.
- For Locations of Barrier Support Structure for Noise Abatement Wall see Noise Abatement Wall or Roadway Plans.
- Contractor shall design and submit for approval by the Engineer Drilled Shaft lengths and reinforcement details to conform with the loading requirements of the Noise Abatement Wall Manufacturer. See Special Provisions.
- Cost of Concrete, Reinforcing Steel, Drilled Shafts and Threaded Anchor Rods included with "Barrier Support Structure for Noise Abatement Wall".

REVISIONS	
NAME	DATE

ILLINOIS DEPARTMENT OF TRANSPORTATION
I-80/94/US 6
KINGERY-BORMAN EXPRESSWAY
BURNHAM ROAD TO US 41
**BARRIER SUPPORT STRUCTURE
FOR NOISE ABATEMENT WALL**

SCALE DATE 07/05 DRAWN BY ACE/CAD CHECKED BY TAE

AMERICAN
CONSULTING ENGINEERS