

GENERAL NOTES

Fasteners shall be ASTM A 325 Type 1. Bolts 7/8" φ, holes 15/16" φ, unless otherwise noted.

Calculated weight of Structural Steel = 254100 lbs (M 270 Grade 50).

Calculated weight of Structural Steel = 18450 lbs (M 270 Grade 36).

No field welding is permitted except as specified in the contract documents.

Reinforcement bars designated (E) shall be epoxy coated.

Bearing seat surfaces shall be constructed or adjusted to the designated elevations within a tolerance of 1/8 inch (0.01 ft.). Adjustment shall be made either by grinding the surface or by shimming the bearings.

The Organic Zinc Rich Primer / Epoxy / Urethane Paint System shall be used for painting of new structural steel except where otherwise noted. The entire system shall be shop applied, with the exception of the exterior surfaces and the bottom of the bottom flange of fascia beams, masked off connection surfaces, and field installed fasteners, all of which shall be touched up and finish coated in the field. The color of the final finish coat for all interior steel surfaces shall be Gray, Munsell No. 5B 7/1. The color of the final finish coat for the exterior and bottom flange of the fascia beams shall be Interstate Green, Munsell No. 7.5G 4/8.

Sloped wall shall be reinforced with welded wire fabric, 6" x 6" - W4.0 x W4.0, weighing 58 lbs. per 100 sq. ft.

Slipforming of the parapets is not allowed.

The embankment configuration shown shall be the minimum that must be placed and compacted prior to construction of the abutments.

The Contractor shall retain the services of an engineering firm, prequalified in the IDOT consultant selection category of Highway Bridges Advanced Typical, for the preparation of the Structural Assessment Report. Contractor's pre-approval shall not be applicable for this project. See Special Provisions.

Current Ratings on file for Existing Structure

Inventory: HS 17.8

Operating: HS 29.8

Live Load Restrictions: No

TOTAL BILL OF MATERIAL

ITEM	UNIT	SUPER	SUB	TOTAL
Granular Backfill for Structures	Cu. Yd.		156	156
Removal of Existing Structures	Each			1
Structure Excavation	Cu. Yd.		245	245
Concrete Structures	Cu. Yd.		156.6	156.6
Concrete Superstructure	Cu. Yd.	429.0		429.0
Bridge Deck Grooving	Sq. Yd.	835		835
Protective Coat	Sq. Yd.	1253		1253
Furnishing and Erecting Structural Steel	L. Sum	1		1
Stud Shear Connectors	Each	2772		2772
Reinforcement Bars, Epoxy Coated	Pound	91340	23700	115040
Aluminum Railing, Type L	Foot	236		236
Sloped wall 4 Inch	Sq. Yd.		386	386
Furnishing Steel Piles HP14x73	Foot		658	658
Driving Piles	Foot		658	658
Name Plates	Each	1		1
Elastomeric Bearing Assembly, Type I	Each		12	12
Anchor Bolts 1"	Each		24	24
Anchor Bolts 1/4"	Each		12	12
Geocomposite Wall Drain	Sq. Yd.		78	78
Pipe Underdrains for Structures, 4"	Foot		151	151
Braced Excavation	Cu. Yd.		102	102

Current Ratings on file for Existing Structure

Inventory: HS 17.8

Operating: HS 29.8

Live Load Restrictions: No

2" PJF (per Article 1051.09 of the Std. Specs.) full width and vertically at edges bonded to abutment cap with suitable adhesive as recommended by supplier.

1/4" x 3/4" Formed joint with bridge relief joint sealer (full width)

Granular Backfill for Structures by Bridge Contractor after superstructure is in place.

Excavation is paid for as Structure Excavation.

Fabric Reinforced Elastomeric Mat according to Sec. 1028 of the Std. Specs and Special Provisions. Fabric mat shall be 24" wide and attached full width and vertically at edges to the abutment cap with a 3/8" x 5" steel plate and 1/2" φ studs with nuts and washers at 12" cts. Cost included with Concrete Superstructure.

*Geotechnical Fabric for French Drains

*Drainage Aggregate

*4" φ Perforated pipe drain

*Included in the cost of Pipe Underdrains for Structures, 4".

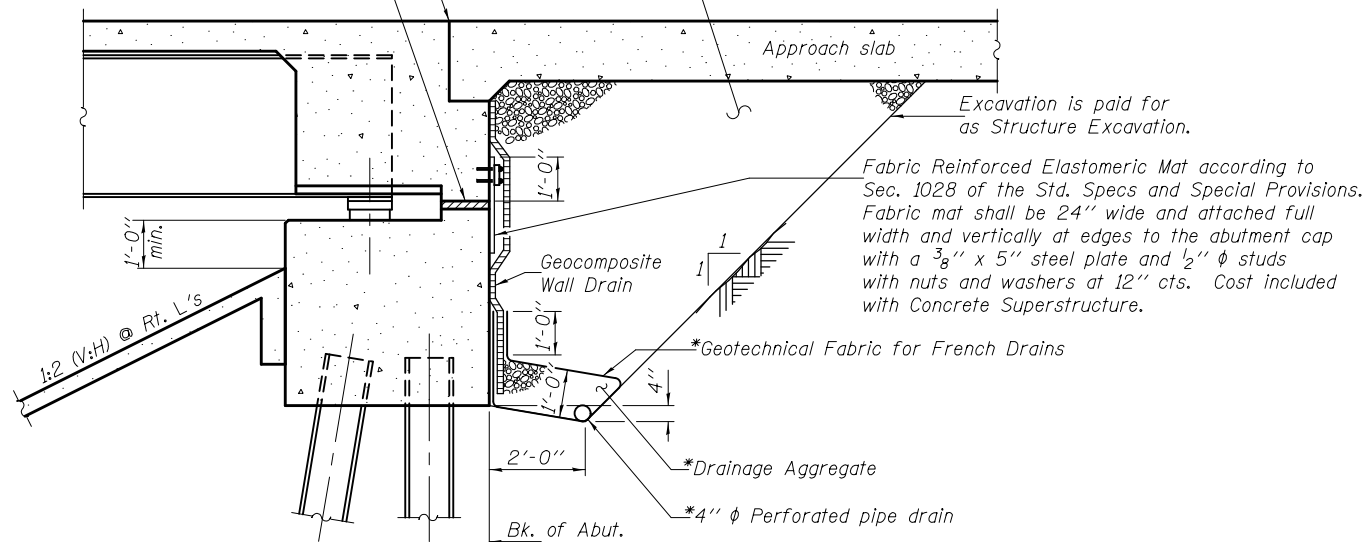

SECTION THRU SEMI-INTEGRAL ABUTMENT

(Horiz. dim. at Rt. L's)

All drainage system components shall extend to 2'-0" from the end of each wingwall except an outlet pipe shall extend until intersecting with the side slopes. The pipes shall drain into concrete headwalls. (See Art. 601.05 of the Standard Specifications and Highway Standard 601101).

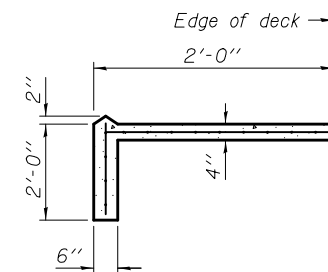

SECTION A-A

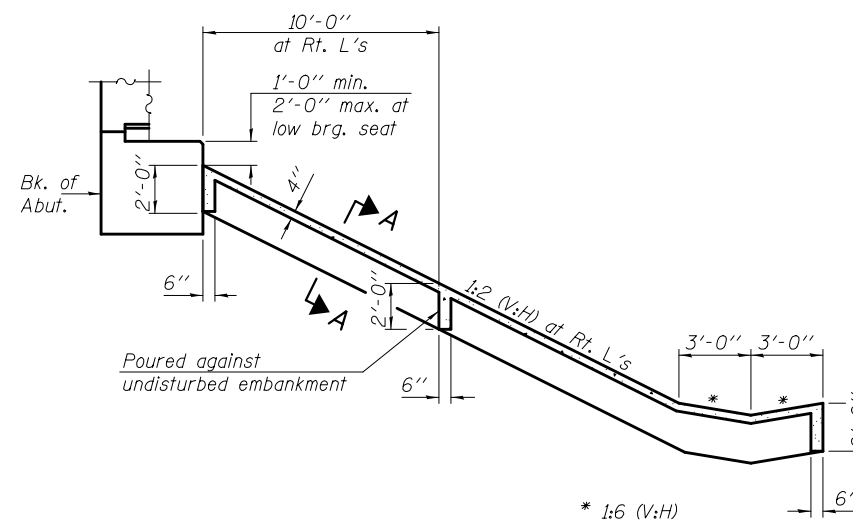

SECTION THRU CONCRETE SLOPEWALL

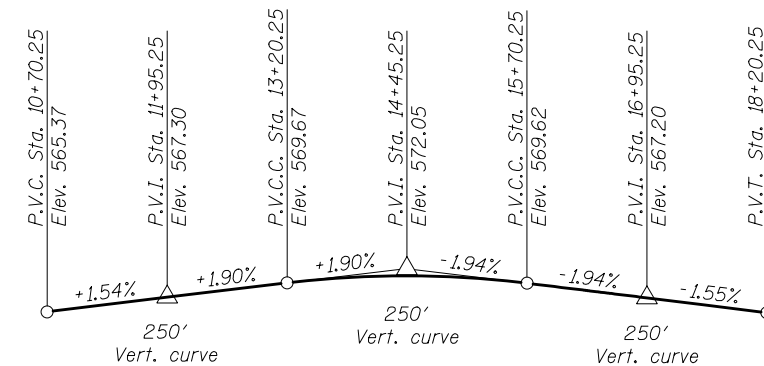

PROFILE GRADE

(Along C Lisbo Road)

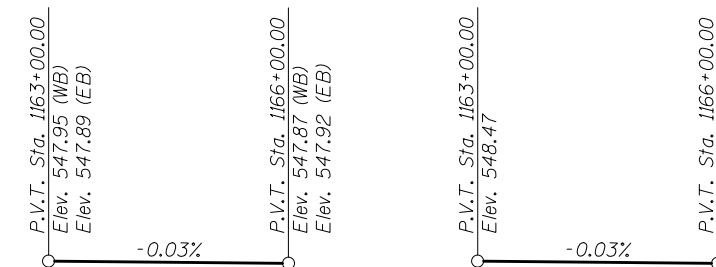

EXISTING PROFILE GRADE

(Along Existing C E.B. and W.B. I-80)

FUTURE PROFILE GRADE

(Along C Future E.B. and W.B. I-80)

INDEX OF SHEETS

- 1 General Plan & Elevation
- 2 General Data
- 3 Footing Layout
- 4-6 Top of Slab Elevations
- 7 Top of North Approach Slab Elevations
- 8 Top of South Approach Slab Elevations
- 9 Superstructure
- 10-11 Superstructure Details
- 12 Diaphragm Details
- 13-14 Bridge Approach Slab Details
- 15 Aluminum Railing, Type L
- 16 Structural Steel
- 17 Structural Steel Details
- 18 Bearing Details
- 19 North Abutment
- 20 South Abutment
- 21 Pier
- 22 HP Pile Details
- 23-24 Soil Boring Logs

DESIGNED - Dewey H. Coultas	EXAMINED - <i>Joanne F. [Signature]</i>
CHECKED - Frank W. Sharpe	PASSED - <i>Carl [Signature]</i>
DRAWN - h.t. duong	
CHECKED - DHC/FWS	

DATE - OCTOBER 9, 2014	REVISOR
	REVISOR

**STATE OF ILLINOIS
DEPARTMENT OF TRANSPORTATION**

**GENERAL DATA
STRUCTURE NO. 032-0124**

SHEET NO. 2 OF 24 SHEETS

F.A.U. RTE. 5966	SECTION (32-2) HBR-6	COUNTY GRUNDY	TOTAL SHEETS 98	SHEET NO. 49
CONTRACT NO. 66B27				
ILLINOIS FED. AID PROJECT				