

PLAN

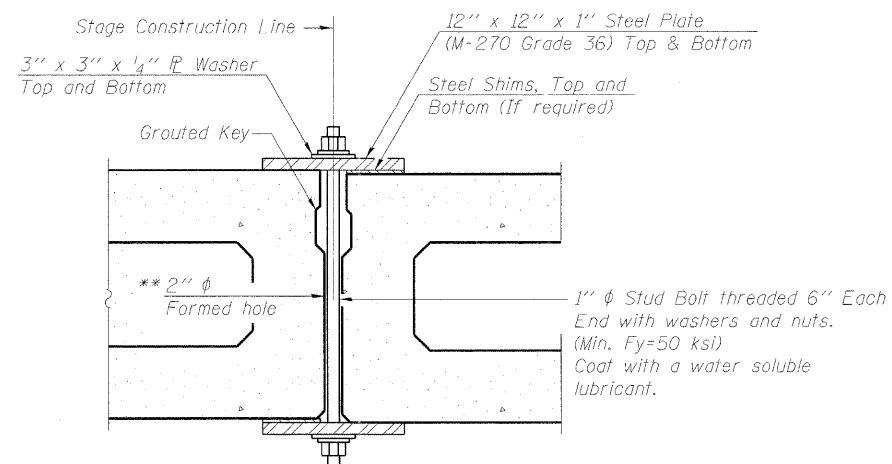

SECTION

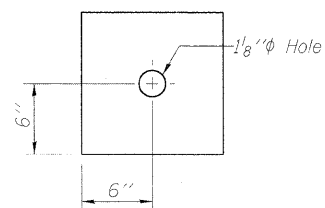

CLAMPING PLATE

SHEAR KEY CLAMPING DETAILS AT STAGE CONST. JT.

Cost included with Precast Prestressed Concrete Deck Beams.
 See Stage Construction Details for traffic lanes.

** Cast semicircular recesses in the sides of each beam adjacent to the stage construction line. These recesses should align to form a hole at the appropriate locations for the clamping device bolts.

FILE NAME = 0760025_78164-014-SuperDel.dgn	USER NAME = cox0283	DESIGNED - BWC	REVISED -	STATE OF ILLINOIS DEPARTMENT OF TRANSPORTATION	SUPERSTRUCTURE DETAILS (SHEET 1 OF 2) STRUCTURE NO. 076-0025	F.A.P. RTE.	SECTION	COUNTY	TOTAL SHEETS	SHEET NO.
	PLOT SCALE =	CHECKED -	REVISED -			132	103BR-1	POPE	38	30
	PLOT DATE = 07/02/2011	DRAWN - BWC	REVISED -			CONTRACT NO. 78164				
		CHECKED - MNM	REVISED -			ILLINOIS FED. AID PROJECT				
SHEET NO. 14 OF 22 SHEETS										