

PROP SN (036-0054)  
IL 94 OVER DIXON CREEK

**EXISTING TYPICAL CROSS SECTION**

(LOOKING SOUTH)  
STA. 342+15 TO STA. 349+75

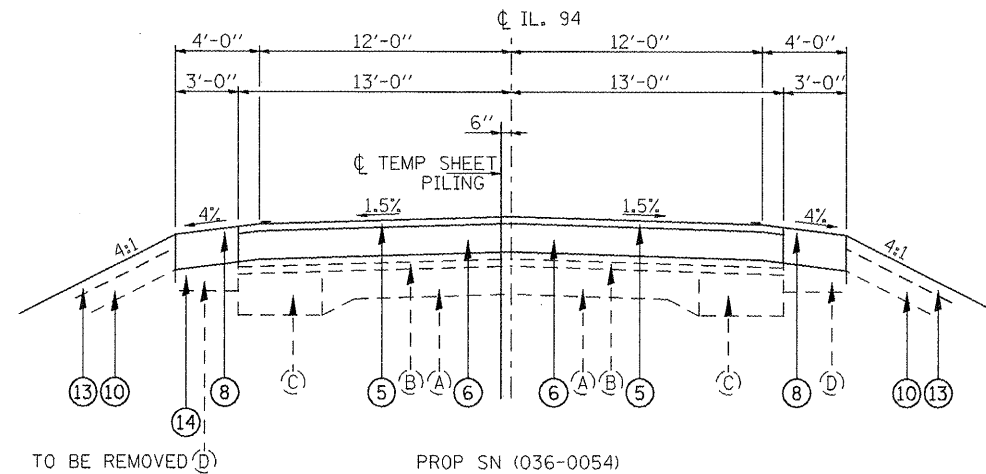

PROP SN (036-0054)  
IL 94 OVER DIXON CREEK

**PROPOSED TYPICAL CROSS SECTION**

(LOOKING SOUTH)  
STA. 343+25 TO STA. 344+59 &  
STA. 348+68 TO STA. 349+75

**LEGEND**

- (A) EXISTING CONCRETE PAVEMENT
- (B) EXISTING OVERLAYS (VAR.) 4"±
- (C) EXISTING BIT. WIDENING
- (D) EXISTING RAP SHOULDER 6"-8"
- (E) EXISTING AGGREGATE SHOULDER
- (F) EXISTING AREA CRACK CONTROL TREATMENT, SYSTEM A
- (G) EXISTING CONCRETE GUTTER
- ① PROPOSED HMA SURFACE REMOVAL, 3/4"
- ② PROPOSED HMA SURFACE REMOVAL, 2"
- ③ PROPOSED LEVELING BINDER (MM), IL-4.75, N50, 3/4"
- ④ PROPOSED HMA SURF. CSE., SUPER D N50, 1 1/2"
- ⑤ PROPOSED HMA SURF. CSE., SUPER D N50, 2"
- ⑥ PROPOSED HMA BINDER CSE., VAR. DEPTH 2" TO 14"
- ⑦ PROPOSED HMA BINDER CSE., 8"
- ⑧ PROPOSED HMA SHOULDER
- ⑨ PROPOSED AGGREGATE SHOULDER TY. B, 8"
- ⑩ EMBANKMENT
- ⑪ PROPOSED GRANULAR EMBANKMENT, SPECIAL, VAR. DEPTH 6" MIN.
- ⑫ GUARDRAIL AGGREGATE EROSION CONTROL
- ⑬ TOPSOIL, EXCAVATION & PLACEMENT, 4"
- ⑭ PROPOSED HMA BINDER COURSE 8" FOR PHASE I TRAFFIC

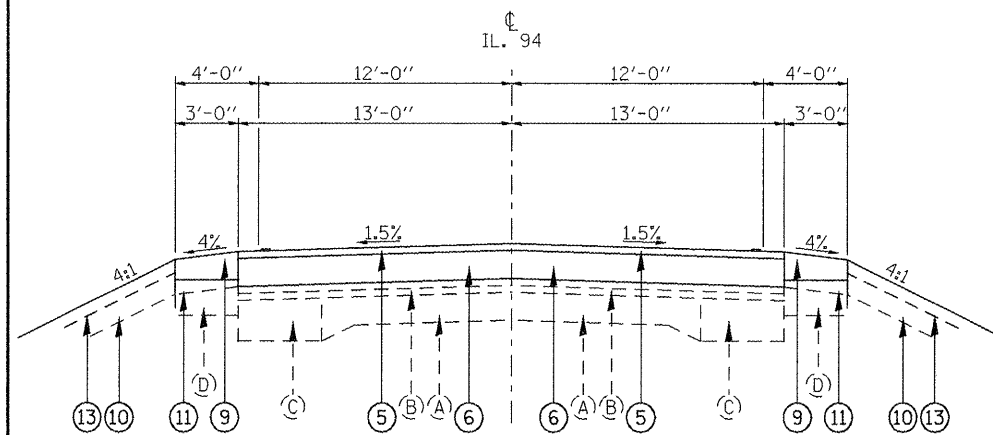

PROP SN (036-0054)  
IL 94 OVER DIXON CREEK

**PROPOSED TYPICAL CROSS SECTION**

(LOOKING SOUTH)  
STA. 342+15 TO STA. 343+25 &  
STA. 349+75 TO STA. 351+15

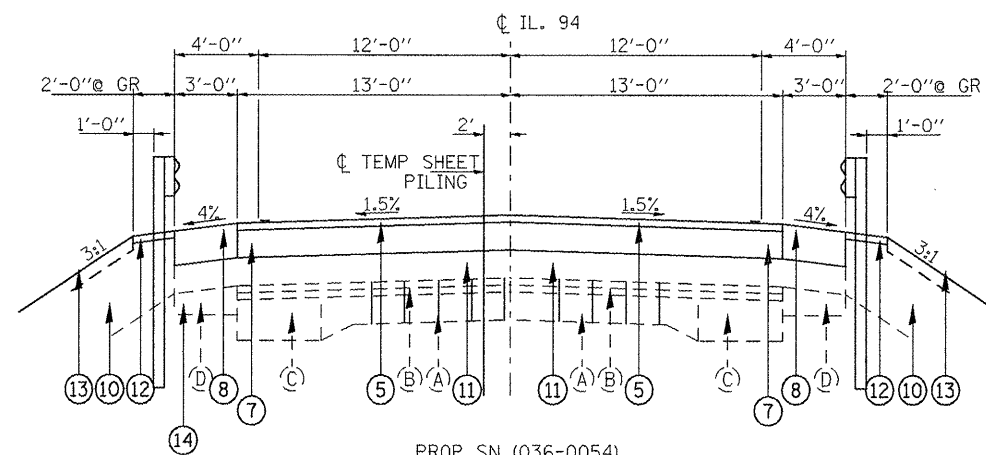

PROP SN (036-0054)  
IL 94 OVER DIXON CREEK

**PROPOSED TYPICAL CROSS SECTION**

(LOOKING SOUTH)  
STA. 344+59 TO STA. 346+74.50  
STA. 347+97.50 TO STA. 348+68

FILE NAME =  
D468083-sh1-plan.dgn

|                              |            |           |
|------------------------------|------------|-----------|
| USER NAME = johnsortv        | DESIGNED - | REVISED - |
| PLOT SCALE = 150.6849' / in. | DRAWN -    | REVISED - |
| PLOT DATE = 8/26/2011        | CHECKED -  | REVISED - |
|                              | DATE -     | REVISED - |

STATE OF ILLINOIS  
DEPARTMENT OF TRANSPORTATION

TYPICAL SECTIONS  
DIXON CREEK

NOT TO SCALE SHEET NO. 1 OF 1 SHEETS STA. 342+15 TO STA. 351+15

| F.A.P. RTE.               | SECTION                   | COUNTY    | TOTAL SHEETS | SHEET NO. |
|---------------------------|---------------------------|-----------|--------------|-----------|
| 534                       | (109B)BR(109-B BR)109RS-6 | HENDERSON | 88           | 12        |
| CONTRACT NO. 68083        |                           |           |              |           |
| ILLINOIS FED. AID PROJECT |                           |           |              |           |