

PLAN
EXISTING GATE BOX

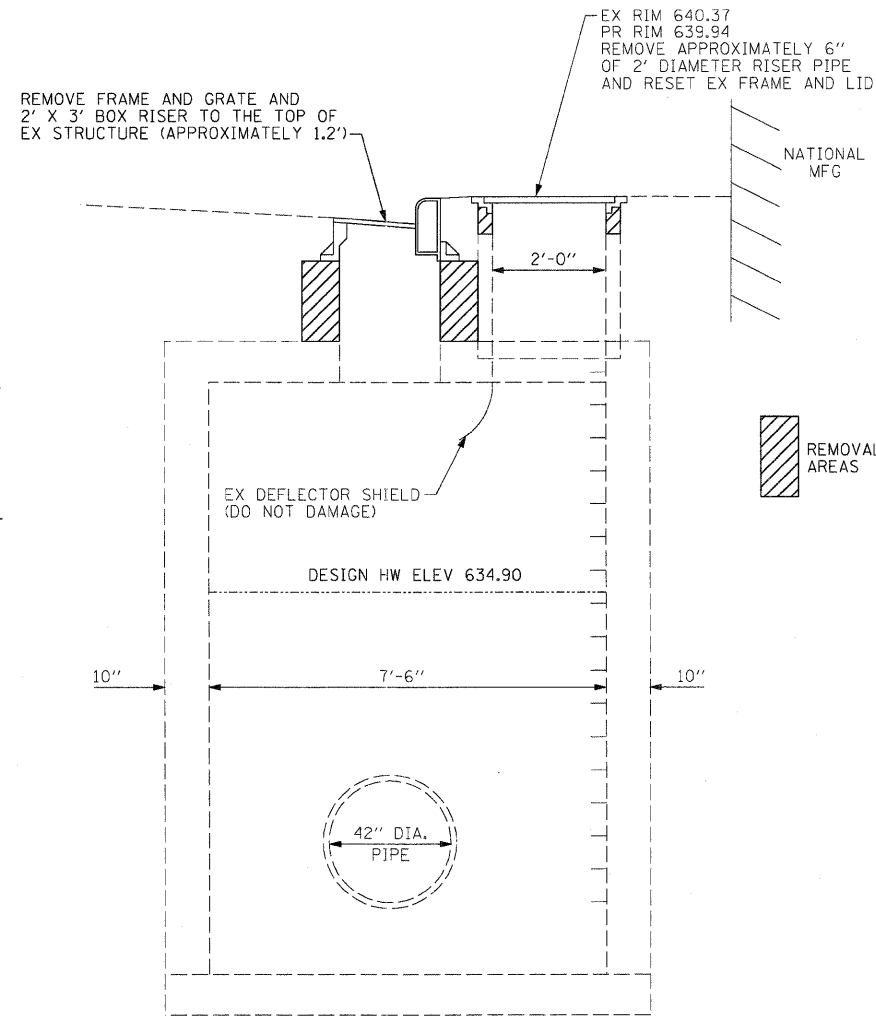

A-A (REMOVAL)

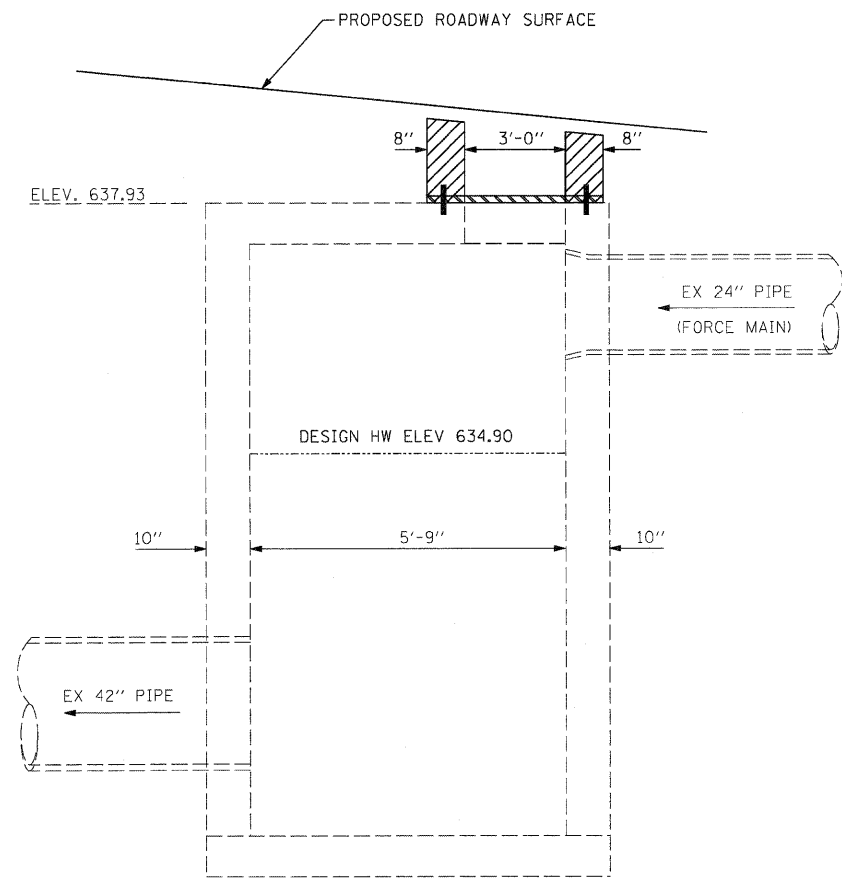

B-B

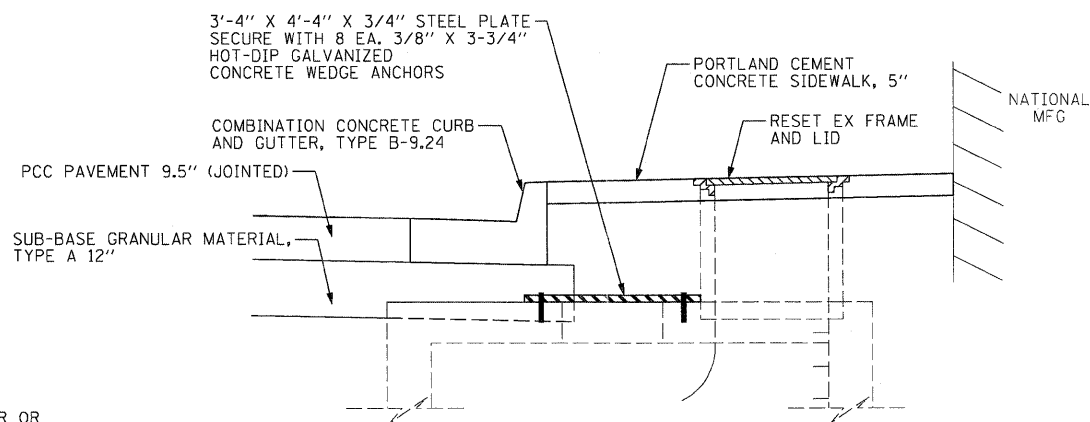

A-A (PROPOSED)

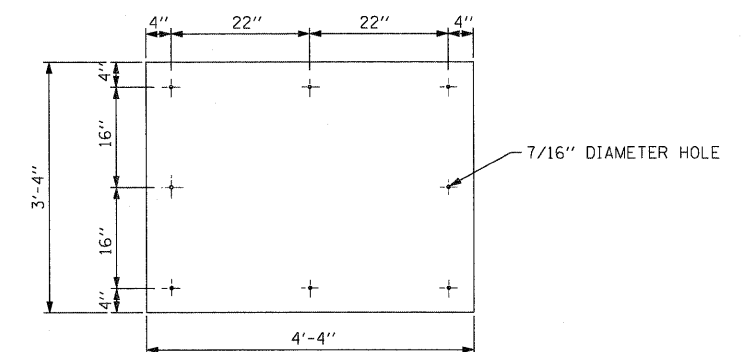

3/4" STEEL PLATE DETAIL

NOTES:

1. STEEL PLATE WILL BE HOT-DIP GALVANIZED ACCORDING TO AASHTO M232.
2. THE CONTRACTOR SHALL BE RESPONSIBLE TO REPAIR OR REPLACE DAMAGES TO THE GATE BOX RESULTING FROM NEGLIGENCE OR THE METHOD OF EXECUTION OF THE WORK.
3. THIS WORK WILL BE DONE ACCORDING TO SECTION 602 AND 603 OF THE STANDARD SPECIFICATIONS AND THIS DETAIL.
4. THIS WORK WILL BE PAID AT THE CONTRACT UNIT PRICE, EACH FOR "DRAINAGE STRUCTURE ADJUSTMENT (SPECIAL)".

DRAINAGE STRUCTURE ADJUSTMENT (SPECIAL)

NTS

FILE NAME =
D264888-shd-detail2.dgn

USER NAME = dwozniarski
DRAWN -
CHECKED -
DATE -

DESIGNED -
DRAWN -
CHECKED -
DATE -

REVISED -
REVISED -
REVISED -
REVISED -

STATE OF ILLINOIS
DEPARTMENT OF TRANSPORTATION

DRAINAGE STRUCTURE ADJUSTMENT (SPECIAL) DETAIL

SCALE: N/A SHEET NO. 1 OF 1 SHEETS STA. TO STA.

F.A.P. RTE.	SECTION	COUNTY	TOTAL SHEETS	SHEET NO.
646	1B-2	WHITESIDE	257	83
CONTRACT NO. 64B80				
FED. ROAD DIST. NO. ILLINOIS FED. AID PROJECT				