

OPTION 1

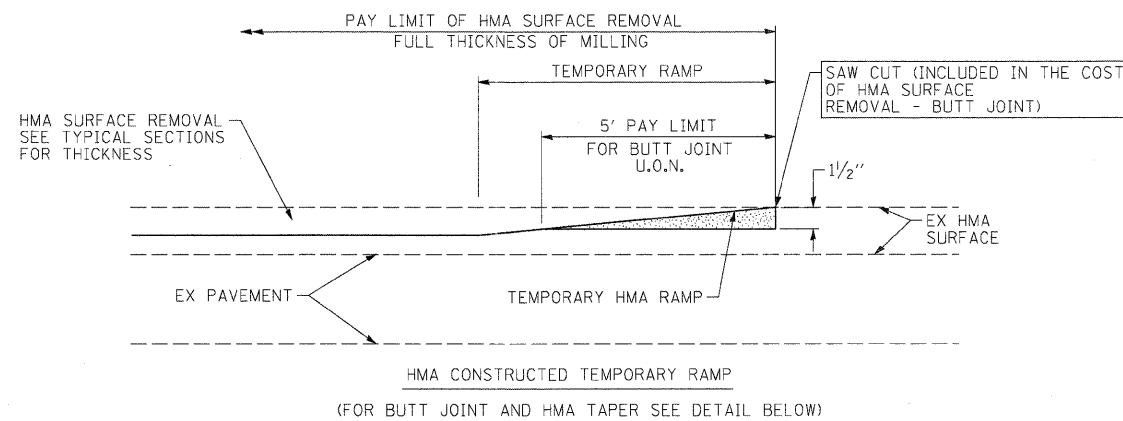

OPTION 2

TYPICAL TEMPORARY RAMP

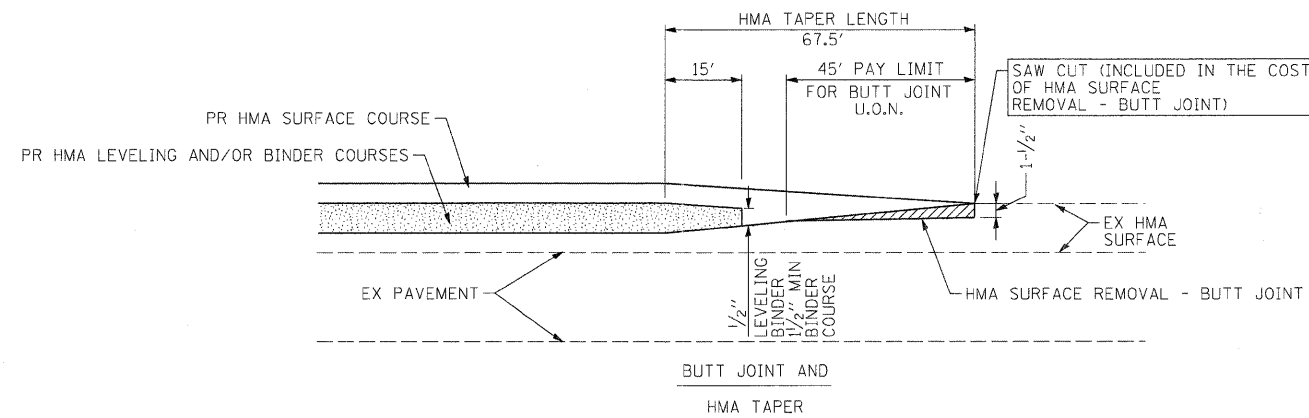

**TYPICAL BUTT JOINT AND HMA TAPER, 1:30
FOR MILLING AND RESURFACING**

NOTES:

1. THE TEMPORARY RAMP SHALL BE CONSTRUCTED IMMEDIATELY UPON REMOVAL OF THE EXISTING HMA SURFACE.
2. THE BUTT JOINT SHALL BE CONSTRUCTED IMMEDIATELY PRIOR TO PLACING THE PROPOSED HMA COURSES.
3. TEMPORARY RAMP LENGTH = 40 X SURFACE REMOVAL THICKNESS.
4. SEE ARTICLE 406.08 AND 406.14 OF THE STANDARD SPECIFICATIONS FOR "HMA SURFACE REMOVAL, BUTT JOINT".
5. THE BUTT JOINT WILL BE PAID FOR AT THE CONTRACT UNIT PRICE PER SQUARE YARD FOR "HOT-MIX ASPHALT SURFACE REMOVAL - BUTT JOINT".

FILE NAME =
D264888-sh-typical4.dgn

USER NAME = dwoznarski	DESIGNED -	REVISED -
	DRAWN -	REVISED -
PLOT SCALE = 5,00000' / IN.	CHECKED -	REVISED -
PLOT DATE = 7/14/2011	DATE - 2-22-2010	REVISED -

**STATE OF ILLINOIS
DEPARTMENT OF TRANSPORTATION**

TYPICAL SECTIONS

SCALE: N/A SHEET NO. 4 OF 4 SHEETS STA. TO STA.

F.A.P. RTE. = 646	SECTION = 1B-2	COUNTY = WHITESIDE	TOTAL SHEETS = 257	SHEET NO. = 15
CONTRACT NO. 64B80				
FED. ROAD DIST. NO. [ILLINOIS] FED. AID PROJECT				