

EXISTING TYPICAL SECTION 1

S-E RAMP
STA 1303+75.43 TO STA 1307+73.31
S-W RAMP
STA 303+66.60 TO STA 309+02.39
E-N RAMP
STA 1122+76.43 TO STA 1125+93.12
STA 1130+92.55 TO STA 1139+79.46

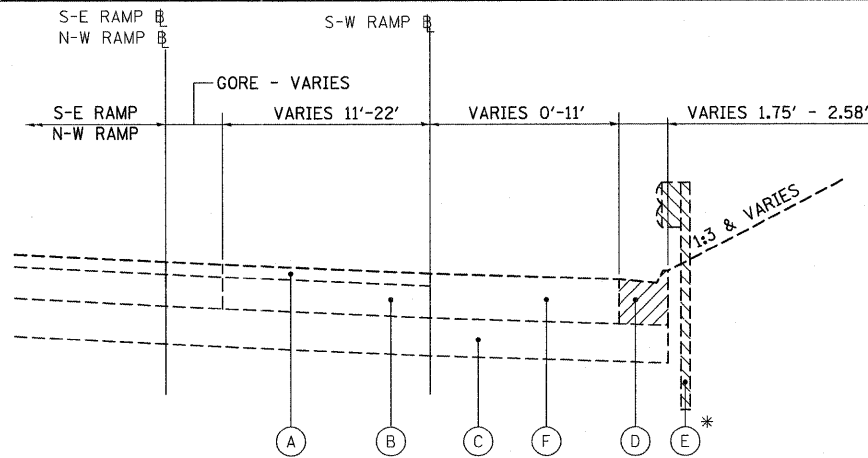

EXISTING TYPICAL SECTION 2

S-W RAMP
STA 300+69.81 TO STA 303+66.60
STA 309+02.39 TO STA 309+97.52

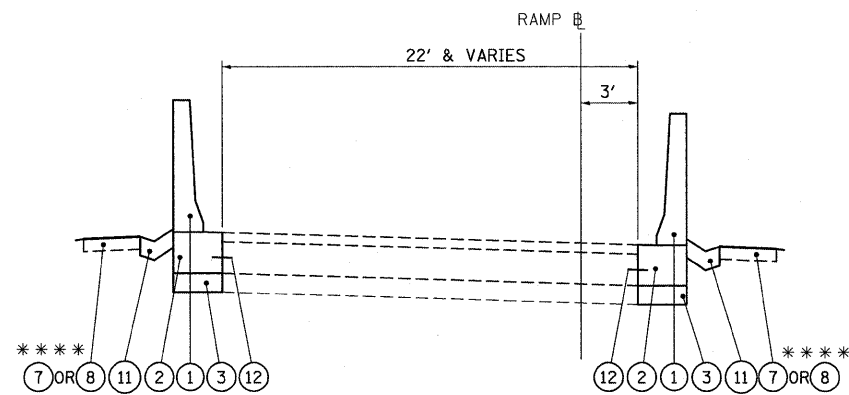

PROPOSED TYPICAL SECTION 1

S-E RAMP
STA 1303+75.43 TO STA 1307+73.31
E-N RAMP
STA 1122+76.43 TO STA 1125+93.12
STA 1130+92.55 TO STA 1139+79.46

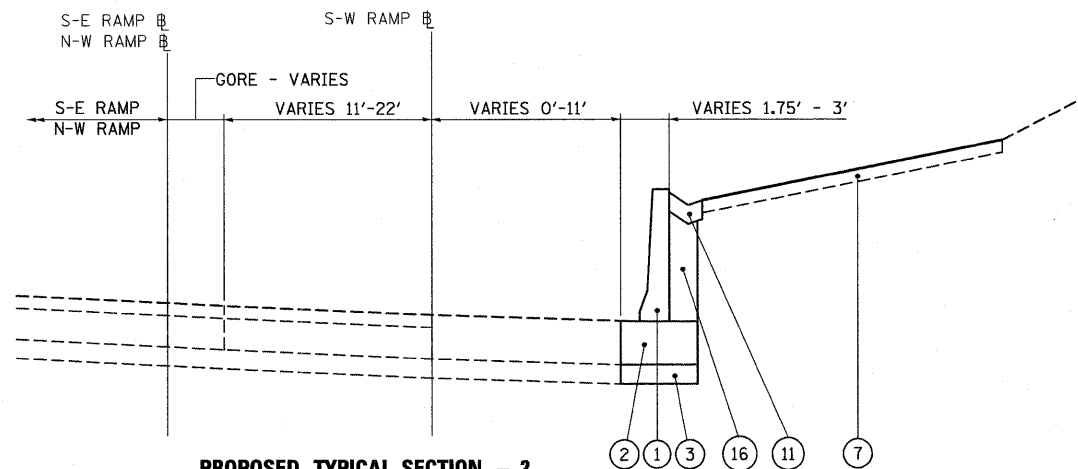

PROPOSED TYPICAL SECTION - 2

S-W RAMP
STA 300+69.81 TO STA 304+25.00

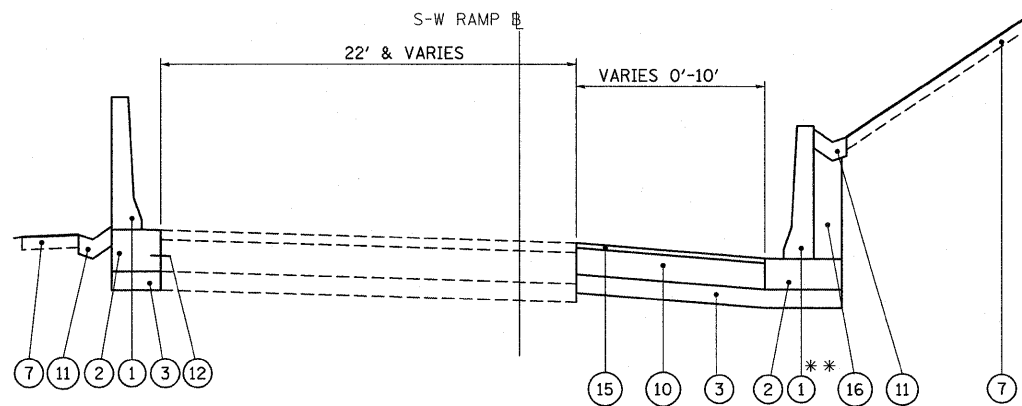

PROPOSED TYPICAL SECTION 3

S-W RAMP
STA 304+25.00 TO STA 309+97.52

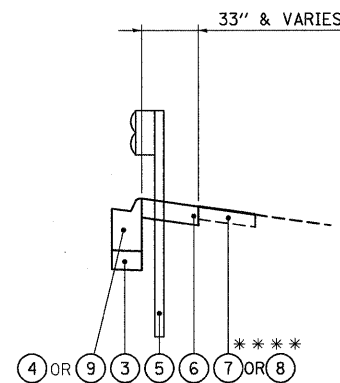

GUARDRAIL TYPICAL SECTION

S-W RAMP
STA 303+86.57 TO STA 305+08.99, LT
S-E RAMP
STA 1303+75.43 TO STA 1304+90.03, RT
E-N RAMP
STA 1132+79.51 TO STA 1134+25.76, LT

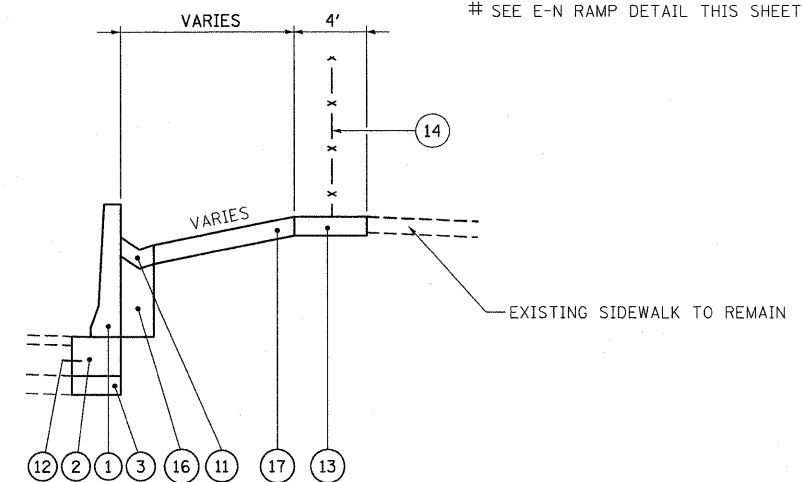

E-N RAMP DETAIL AT DES PLAINES STREET

E-N RAMP
STA 1133+30.73 TO STA 1135+28.12, RT

EXISTING LEGEND:

- (A) HOT-MIX ASPHALT OVERLAY, ±3"
- (B) P.C.C. PAVEMENT, 10" & VARIES
- (C) SUB-BASE GRANULAR MATERIAL, 6" & VARIES
- (D) COMBINATION CONCRETE CURB AND GUTTER
- (E) STEEL PLATE BEAM GUARDRAIL
- (F) HOT-MIX ASPHALT SHOULDER, 10" & VARIES



PROPOSED LEGEND:

- (1) CONCRETE BARRIER WALL (SPECIAL)
 - (2) CONCRETE BARRIER BASE
 - (3) SUBBASE GRANULAR MATERIAL, TYPE B 6"
 - (4) COMBINATION CONCRETE CURB AND GUTTER, TYPE M-4.12
 - (5) STEEL PLATE BEAM GUARDRAIL, TYPE A, 6 FOOT POSTS
 - (6) HOT-MIX ASPHALT SHOULDERS, 6" (IN 2 LIFTS)
 - (7) TOPSOIL FURNISH AND PLACE, 6" AND SEEDING, CL 2A
 - (8) MAINTENANCE ACCESS PATH (HMA SHOULDERS, 6")
 - (9) COMBINATION CONCRETE CURB AND GUTTER, TYPE M-4.24
 - (10) HOT-MIX ASPHALT SHOULDERS, 8 1/2" (IN 3 LIFTS)
 - (11) CONCRETE GUTTER, TYPE B
 - *** (12) TIE BAR
 - (13) PCC SIDEWALK 5 INCH
 - (14) ORNAMENTAL FENCE, WROUGHT IRON
 - (15) HOT-MIX ASPHALT SURFACE COURSE, MIX "D", N70, 1 1/2"
 - (16) POROUS GRANULAR BACKFILL
 - (17) AGGREGATE SURFACE COURSE, TYPE B, 4"
- * SEE REMOVAL PLANS FOR LIMITS OF EXISTING GUARDRAIL
- ** PROPOSED RETAINING WALL ALONG S-W RAMP FROM STA 305+69.16 TO STA 307+53.24
- *** LONGITUDINAL JOINT TIE BARS SHALL BE NO. 6 @ 24" CENTERS IN ACCORDANCE WITH DETAILS FOR LONGITUDINAL CONSTRUCTION JOINT SHOWN ON STANDARD 420001
- *** SEE LANDSCAPING PLAN AND PROPOSED ROADWAY PLAN FOR LIMITS
- # SEE E-N RAMP DETAIL THIS SHEET

FILE NAME = 05_D60P67-sht-typical.dgn

USER NAME = USER:3690
PLOT SCALE = 1:5
PLOT DATE = 9/8/2011

DESIGNED - DLD
DRAWN - ED
CHECKED - AAC
DATE - 08/04/11

REVISED -
REVISED -
REVISED -
REVISED -

STATE OF ILLINOIS
DEPARTMENT OF TRANSPORTATION

TYPICAL SECTIONS

SCALE: NONE SHEET NO. 1 OF 1 SHEETS STA. TO STA.

F.A.I. RTE.	SECTION	COUNTY	TOTAL SHEETS	SHEET NO.
90/34 7250	2011-055-I	COOK	107	6
ILLINOIS FED. AID PROJECT			CONTRACT NO. 60P67	