

FRONT ELEVATION

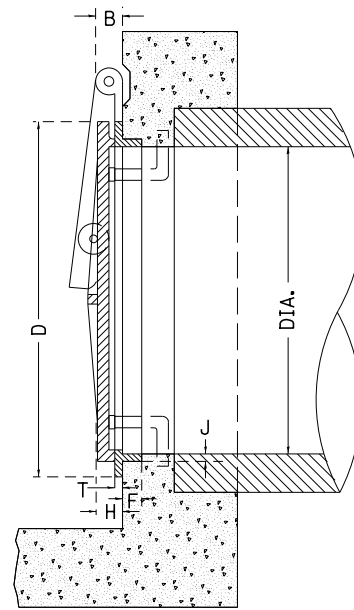

SECTION

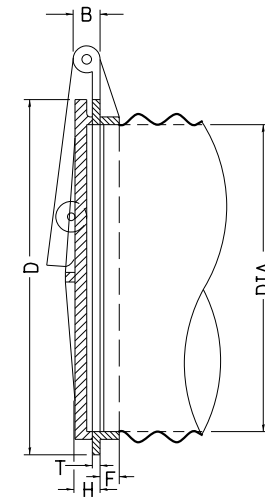

SECTION SHOWING METHOD OF APPLICATION TO CORRUGATED METAL PIPE

IT IS INTENDED THAT THE AUTOMATIC FLAP GATES SHALL BE A COMMERCIAL PRODUCT PRODUCED BY A RELIABLE MANUFACTURER. THE GATE MAY BE MADE OF CAST IRON, CAST STEEL OR OTHER SUITABLE MATERIALS. THE DESIGN MAY DIFFER FROM THE DRAWING IF IT WILL WORK IN A SATISFACTORY, TROUBLE FREE MANNER AND WILL WITHSTAND THE WATER PRESSURE AT THE INSTALLATION LOCATION. THE GATE SHALL BE APPROVED BY THE ENGINEER.

THE SIZE OF AUTOMATIC FLAP GATES SHALL REFER TO THE DIAMETER OF THE OUTLET PIPE OR OPENING.

THIS WORK SHALL BE PAID FOR AT THE CONTRACT UNIT PRICE EACH FOR FLAP GATES OF THE SIZE SPECIFIED AND SHALL INCLUDE ALL MATERIALS AND COMPLETE INSTALLATION.

TABLE OF DIMENSIONS

DIAM	A	B	C	D	E	F	G	H	J	T
8"	10 3/4"	1 3/8"	5 1/16"	10"	1/2"	1 1/8"	3 9/16"	1 1/4"	3/8"	3/8"
10"	12 3/4"	1 3/8"	7 1/8"	12 1/4"	1/2"	1 1/8"	4 3/8"	1 1/2"	1/2"	7/16"
12"	14 3/4"	1 3/8"	8 1/2"	14 1/2"	1/2"	1 1/8"	5 1/8"	1 1/2"	1/2"	1/2"
14"	17 1/4"	1 3/8"	9 7/8"	16 3/4"	1/2"	1 1/4"	5 15/16"	1 1/2"	1/2"	9/16"
15"	17 3/4"	1 3/8"	10 5/8"	17 3/4"	1/2"	1 1/4"	6 1/4"	1 1/2"	1/2"	9/16"
16"	19 1/4"	1 3/8"	11 1/4"	18 3/4"	1/2"	1 1/4"	6 5/8"	1 1/2"	1/2"	9/16"
18"	22 1/4"	2"	12 5/8"	21"	3/4"	1 9/16"	7 7/16"	1 3/4"	9/16"	9/16"
20"	24 3/4"	2"	14 1/8"	23 3/4"	3/4"	1 3/8"	8 1/4"	1 3/4"	5/8"	5/8"
21"	25 1/4"	2"	14 7/8"	24 1/4"	3/4"	1 3/8"	8 9/16"	1 3/4"	5/8"	5/8"
24"	28 1/4"	2"	17"	27 1/2"	3/4"	1 1/2"	9 3/4"	1 3/4"	5/8"	5/8"
30"	35 1/4"	2 1/2"	20 1/2"	34"	1"	1 9/16"	12"	2"	1 1/16"	5/8"
36"	41 1/2"	2 1/2"	25"	40 7/8"	1"	2 1/16"	14 7/16"	2 1/4"	1 1/8"	11/16"
42"	47 1/2"	2 1/2"	29 3/4"	47"	1"	2 5/16"	16 5/8"	2 1/4"	1 1/8"	3/4"
48"	53 1/2"	2 1/2"	34"	54"	1"	2 3/4"	19 1/16"	2 1/4"	1 3/8"	3/4"
54"	60 3/4"	2 1/2"	38"	62 1/4"	1 1/4"	2 3/4"	22"	3"	1 1/2"	7/8"
60"	67"	2 1/2"	42"	68 1/2"	1 1/4"	2 3/4"	24 1/4"	3"	1 1/2"	15/16"
66"	73 3/8"	2 1/2"	47"	75"	1 1/4"	2 7/8"	26 1/2"	3"	1 1/2"	1"
72"	79"	2 1/2"	51"	82"	1 1/4"	3"	29"	3"	1 1/2"	1"
78"	86"	2 1/2"	55 1/4"	88 3/4"	1 1/4"	3 1/2"	31 3/8"	3"	1 5/8"	1 1/8"
84"	92 1/2"	3 1/2"	59 1/2"	95 1/2"	1 1/2"	3 1/2"	33 3/4"	3"	1 3/4"	1 1/4"

AUTOMATIC FLAPGATE DETAIL

FILE NAME = V:\3195\66883 (South Section)\CADD Sheets\0366883-sht-details-28.dgn	USER NAME = bdecreene	DESIGNED - LDZ	REVISED -	STATE OF ILLINOIS DEPARTMENT OF TRANSPORTATION	IL. RTE. 47 DETAILS	F.A.P. RTE. 326	SECTION (110)R, BR & BR-1	COUNTY GRUNDY	TOTAL SHEETS 644	SHEET NO. 478		
PLOT SCALE = 2.0000' / in.	CHECKED - DJD	REVISED -	SCALE: N/A			SHEET NO. 28 OF 31 SHEETS	STA. N/A	TO STA. N/A	CONTRACT NO. 66883			
PLOT DATE = 8/6/2013	DATE - 7/15/2013	REVISED -	FED. ROAD DIST. NO. ILLINOIS FED. AID PROJECT									