

RURAL SIDEROAD INTERSECTION SHOULDER DETAIL

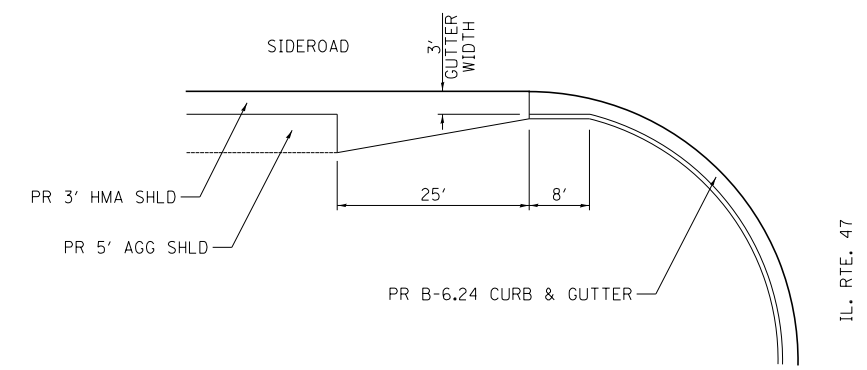

CURB & GUTTER TO SHOULDER TRANSITION AT SIDEROADS DETAIL

NEAT LINE REMOVAL TO BE CUT WITH AN ASPHALT CUTTING WHEEL ATTACHED TO A GRADER OR SIMILAR METHOD APPROVED BY THE ENGINEER.

REMOVAL OF EXISTING HMA SHOULDER TO BE PAID FOR AS PAVED SHOULDER REMOVAL.

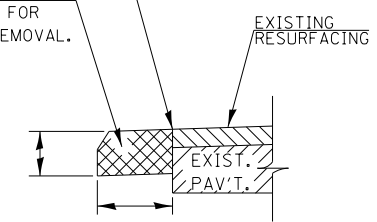

REMOVAL OF EXISTING HMA SHOULDER

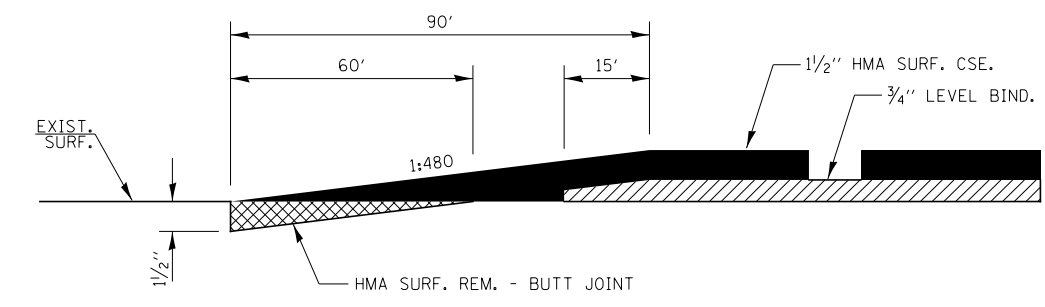

BUTT JOINT DETAIL SIDEROADS & NORTH CONNECTION

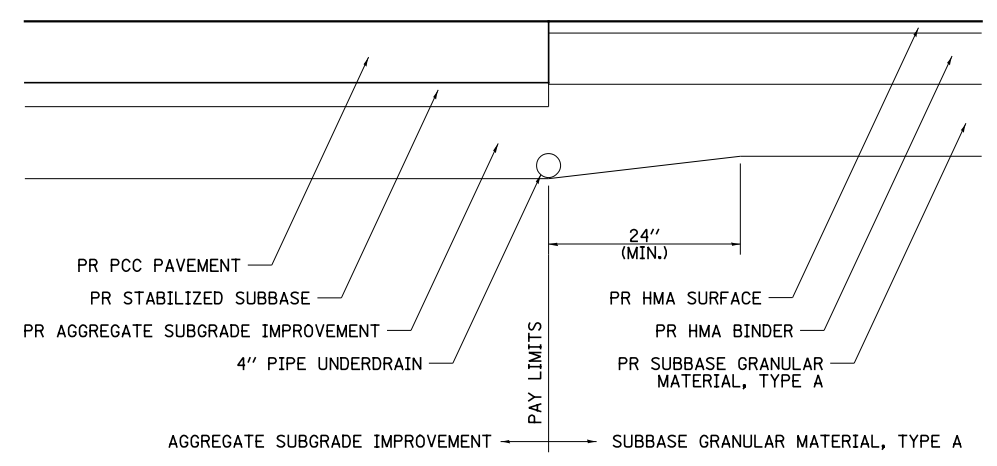

TRANSITION FROM MAINLINE TO SIDE ROAD PAVEMENT

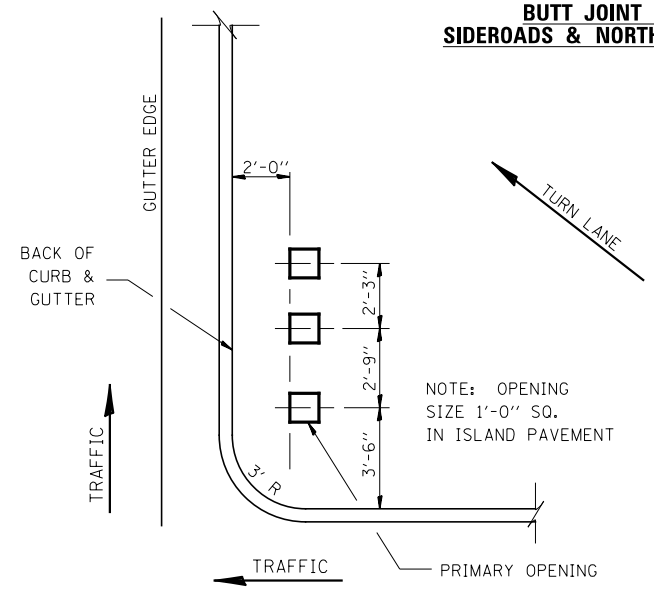

ISLAND SIGN POST SPACING DETAIL

NOTE: THE ENGINEER SHALL DETERMINE THE NUMBER OF OPENINGS REQUIRED.

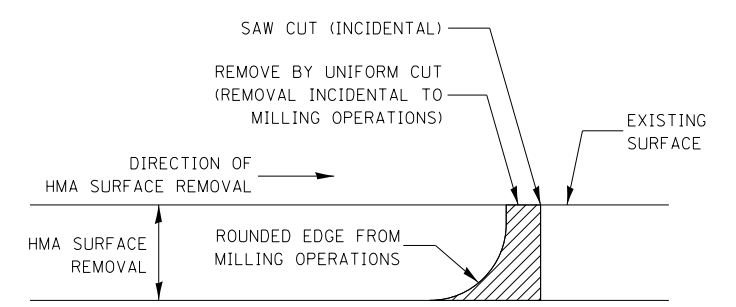

NOTE: WHEN MILLING OPERATIONS PRODUCE A ROUNDED EDGE, THEN A SAW CUT SHALL BE USED TO MANUFACTURE A PERPENDICULAR EDGE AS SHOWN IN THE DETAIL. THE ENGINEER SHALL BE THE SOLE JUDGE CONCERNING THE USE OF THIS DETAIL

HMA DETAIL AT BUTT JOINTS

MISCELLANEOUS PAVEMENT DETAILS

FILE NAME =	USER NAME = bdecreane	DESIGNED - LDZ	REVISED -
V:\3195\66883 (South Section)\CADD Sheets\0366883-sht-details-13.dgn		DRAWN - SGM	REVISED -
PLOT SCALE = 2.0000' / in.		CHECKED - DJD	REVISED -
PLOT DATE = 8/6/2013		DATE - 7/15/2013	REVISED -

**STATE OF ILLINOIS
DEPARTMENT OF TRANSPORTATION**

IL. RTE. 47 DETAILS	
SCALE: N/A	SHEET NO. 13 OF 31 SHEETS
STA. N/A	TO STA. N/A

F.A.P. RTE.	SECTION	COUNTY	TOTAL SHEETS	SHEET NO.
326	(110)R, BR & BR-1	GRUNDY	644	463
CONTRACT NO. 66883				
FED. ROAD DIST. NO. ILLINOIS FED. AID PROJECT				