

FRAMING PLAN

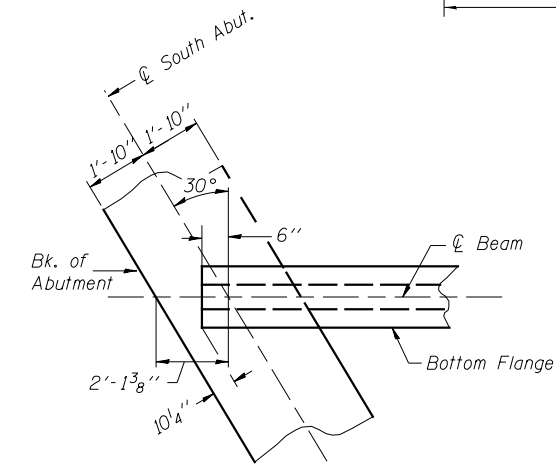

DETAIL A

INTERIOR BEAM MOMENT TABLE		
0.5 Sp. 1		
I	(in ⁴)	392,638
I'	(in ⁴)	770,576
S_b	(in ³)	12,224
S_b'	(in ³)	16,326
S_t	(in ³)	12,715
S_t'	(in ³)	48,772
$DC1$	(k/')	1.60
M_{DC1}	(k)	1,954
$DC2$	(k/')	0.26
M_{DC2}	(k)	322
DW	(k/')	0.40
M_{DW}	(k)	490
$M_{\pm IM}$	(k)	1,951

INTERIOR BEAM REACTION TABLE		
Abut.		
R_{DC1}	(k)	79.1
R_{DC2}	(k)	12.9
R_{DW}	(k)	19.8
$R_{\pm IM}$	(k)	107.6
R_{Total}	(k)	219.4

I : Non-composite moment of inertia of beam section (in.⁴).
 I' : Composite moment of inertia of beam section (in.⁴).
 S_b : Non-composite section modulus for the bottom fiber of the prestressed beam (in.³).
 S_b' : Composite section modulus for the bottom fiber of the prestressed beam (in.³).
 S_t : Non-composite section modulus for the top fiber of the prestressed beam (in.³).
 S_t' : Composite section modulus for the top fiber of the prestressed beam (in.³).
 $DC1$: Un-factored non-composite dead load (kips/ft.).
 M_{DC1} : Un-factored moment due to non-composite dead load (kip-ft.).
 $DC2$: Un-factored long-term composite (superimposed excluding future wearing surface) dead load (kips/ft.).
 M_{DC2} : Un-factored moment due to long-term composite (superimposed excluding future wearing surface) dead load (kip-ft.).
 DW : Un-factored long-term composite (superimposed future wearing surface only) dead load (kips/ft.).
 M_{DW} : Un-factored moment due to long-term composite (superimposed future wearing surface only) dead load (kip-ft.).
 $M_{\pm IM}$: Un-factored live load moment plus dynamic load allowance (impact) (kip-ft.).

* Fabricator shall locate to miss strands within permissible tolerances.

$\frac{3}{4}$ " ϕ A307 Bolts with lock nuts., typ. Bolts through the concrete web shall be tightened to snug tight only.

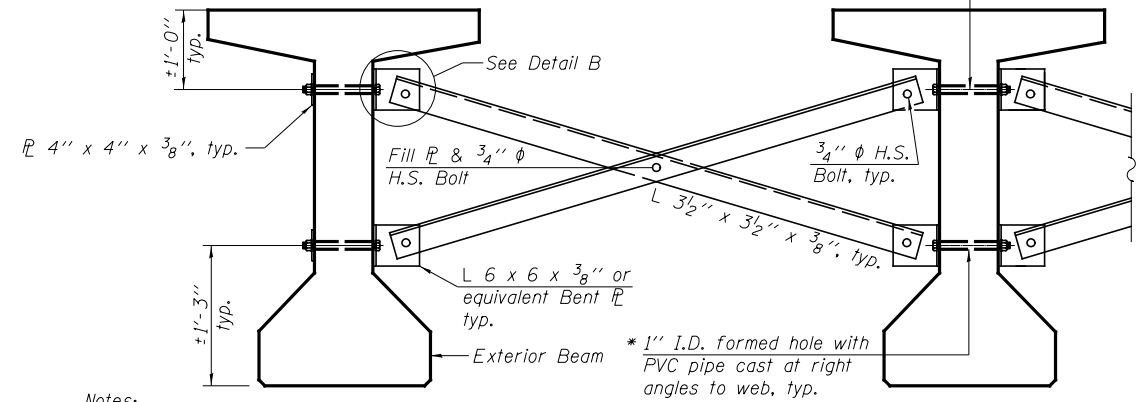

Notes:
 All material for bracing shall be hot dip galvanized according to AASHTO M111 unless otherwise noted.
 Two hardened washers are required for each set of oversized holes.
 All holes shall be $\frac{15}{16}$ " ϕ unless otherwise noted.
 $\frac{5}{16}$ " x 3" x 3" plate washers are required over all slotted holes.
 All bolts shall be galvanized according to AASHTO M232.
 Bracing shall be installed as beams are erected and tightened as soon as possible during erection.
 Permanent bracing shall not be paid for separately, but shall be included in the cost of Furnishing and Erecting Precast Prestressed Concrete Bulb T-Beams.
 All structural steel for permanent bracing shall be AASHTO M 270 Grade 50.

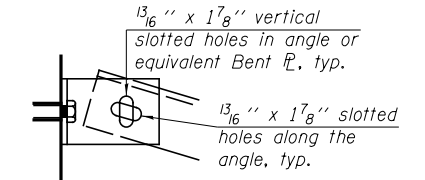

DETAIL B

PERMANENT BRACING DETAILS FOR BULB T-BEAMS