

(AASHTO M 259 Details) (AASHTO M 273 Details)

SECTION C-C

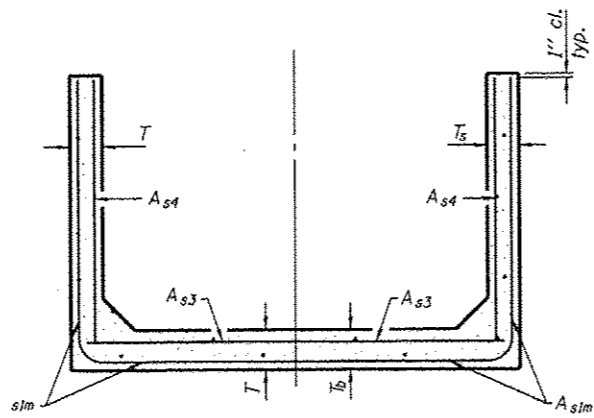

(AASHTO M 259 Details) (AASHTO M 273 Details)

SECTION D-D

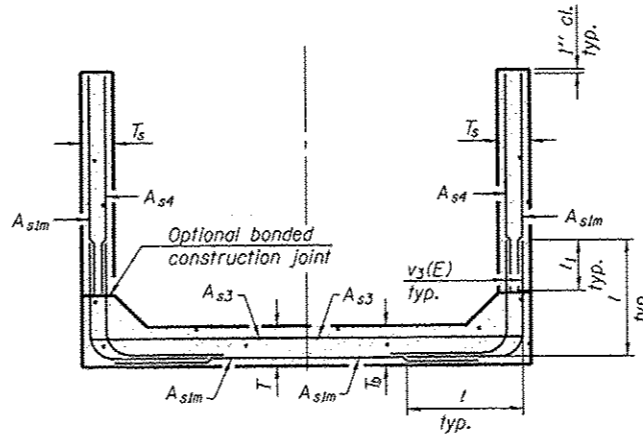

(AASHTO M 259 Details) (AASHTO M 273 Details)

ALTERNATE SECTION D-D

T(in.), T _s (in.)	Reinforcing Steel A _{slm} (in. ² /ft.)											
	2	3	4	5	6	7	8	9	10	11	12	
4	0.19	0.15										
5	0.26	0.21	0.18									
6		0.26	0.23	0.22								
7		0.33	0.59	0.27	0.28							
8			0.43	0.39	0.36	0.34	0.40					
9				0.43	0.40	0.37	0.36	0.48				
10				0.47	0.44	0.41	0.38	0.42	0.56			
11					0.54	0.46	0.41	0.50	0.65			
12						0.50	0.45	0.46	0.75			

(A_{slm} reinforcement based upon welded wire fabric conforming to AASHTO M 55 or M 22).

1 DIMENSION

- #3 bar = 2'-0"
- #4 bar = 2'-8"
- #5 bar = 3'-4"
- #6 bar = 3'-11"

Notes:

Alternate Section D-D is provided to allow the Contractor the option of casting the bottom slab of the end section first followed by construction of the sidewalls using conventional forming methods. Shop drawings that detail slab thickness and reinforcement layout shall be submitted to the Engineer for review and approval when using Alternate Section D-D.

The size and spacing of the v₃(E) bars shall provide a minimum reinforcement area along each face of the walls (in.²/ft.) equal to 1.10*(A_{slm}). v₃(E) bars may consist of #3 thru #6 size reinforcement bars and the longitudinal spacing shall not exceed the lesser of the wall thickness or 8 inches.

Bonded construction joints shall be prepared according to Article 503.09 of the Standard Specifications.

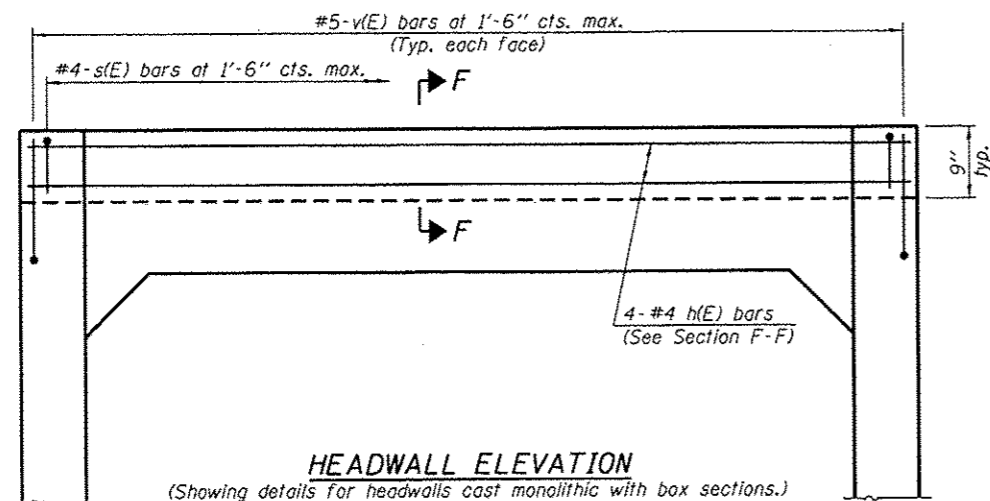

(Showing details for headwalls cast monolithic with box sections.)
(Allow sidewall reinforcement to extend into end of headwall.)

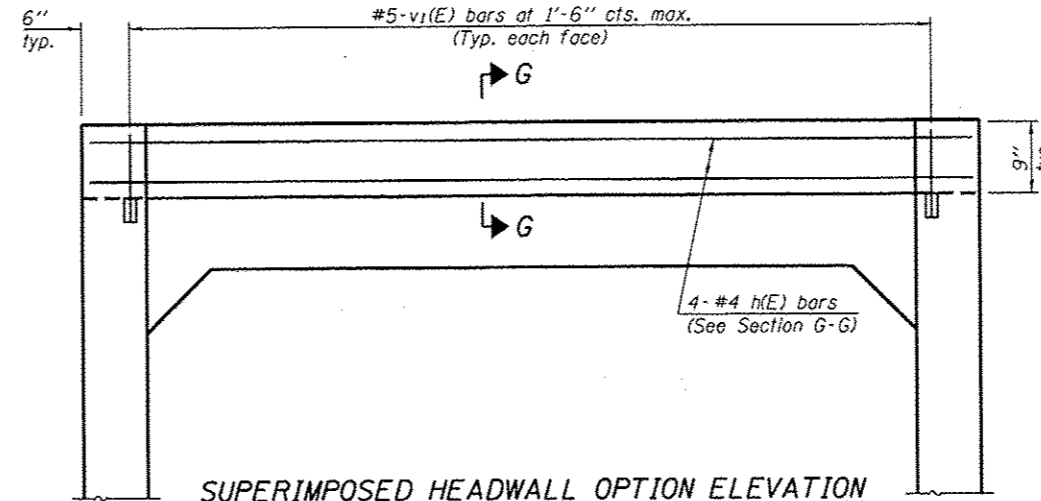

SUPERIMPOSED HEADWALL OPTION ELEVATION

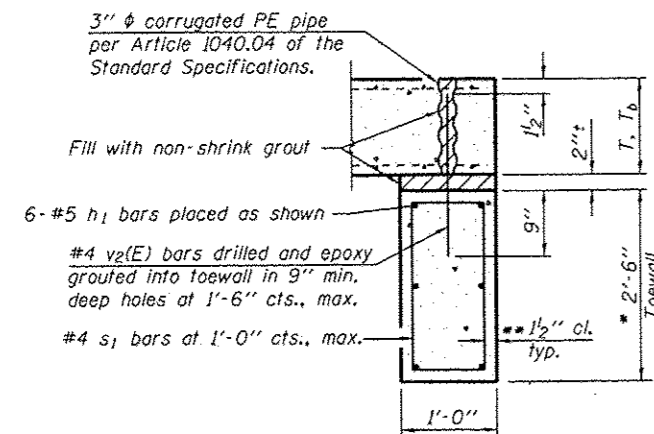
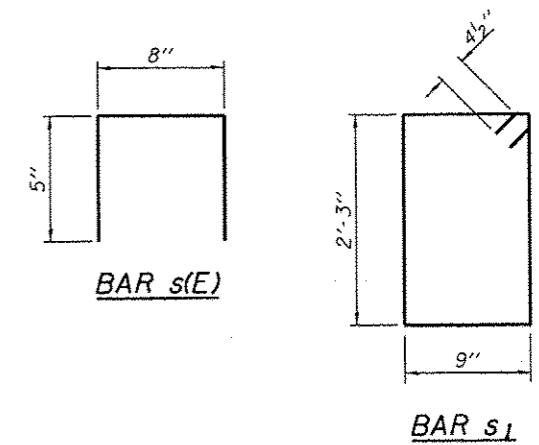

SECTION E-E

TOEWALL CONSTRUCTION SEQUENCE

1. Perform excavation and construct toewall.
2. Backfill accordingly and place bedding for precast box culvert end sections.
3. Set precast box culvert end sections in place.
4. Drill and epoxy grout reinforcement in toewall in accordance with Section 584 of the Standard Specifications.
5. Pressure grout voids using non-shrink grout conforming to Section 1024 of the Standard Specifications.

* The Contractor may furnish a precast or cast-in-place toewall. The Contractor shall be responsible for the strength and stability of the precast toewall during handling. Additional lifting points may be required depending upon the length of the toewall or the Contractor may need to modify the design of the toewall for the proposed handling method.

** If soil conditions permit, the sides of the toewall may be poured directly against the soil. The clear cover on the sides of the toewall shall be increased to 3" by increasing the thickness of the toewall.

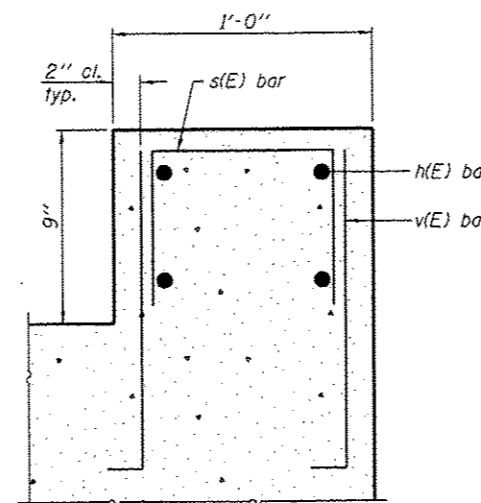

SECTION F-F

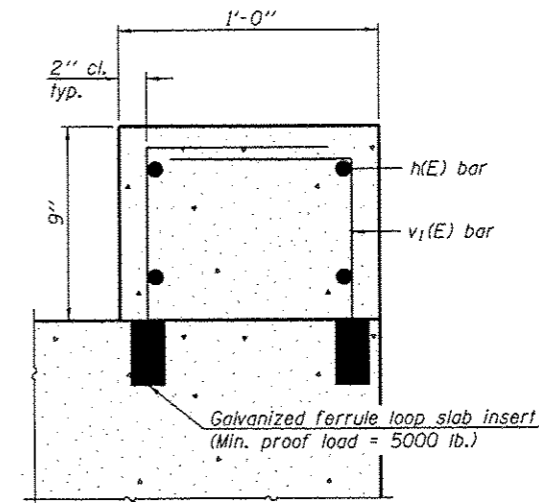

SECTION G-G

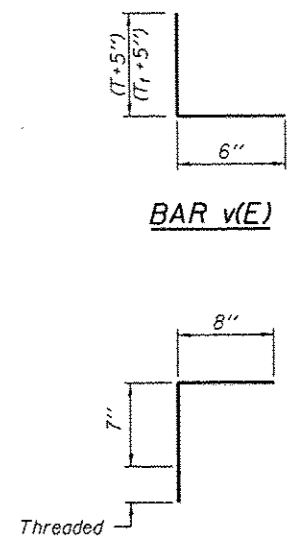

BAR v_1(E)

(Sheet 2 of 3)

DESIGNED -	EXAMINED -	DATE -	STATE OF ILLINOIS DEPARTMENT OF TRANSPORTATION	SINGLE CELL PRECAST BOX CULVERT END SECTIONS WITH PIPE GRATES	F.A.S. RTE. 226	SECTION 3T & 3BR-1	COUNTY HENRY	TOTAL SHEETS 210	SHEET NO. 71
CHECKED -	PASSED -	ENGINEER OF BRIDGE DESIGN			CONTRACT NO. 64F25				
DRAWN -	ENGINEER OF BRIDGES AND STRUCTURES				ILLINOIS FED. AID PROJECT				
CHECKED -					SHEET NO. 2 OF 3 SHEETS				