

See sheet 5 of 12 for scupper location relative to parapet.

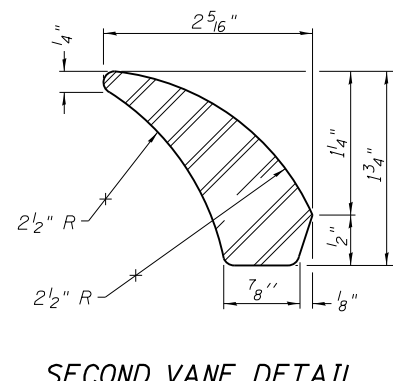
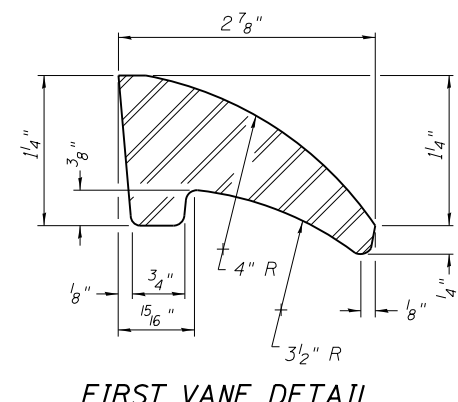

* Corrugated pipe extension to the end of downspout to be done by others

BILL OF MATERIAL

ITEM	UNIT	QUANTITY
Drainage Scupper, DS-33	Each	6

DS-33 7-1-10

FILE NAME =	USER NAME = dahhnr	DESIGNED -	REVISED -	STATE OF ILLINOIS DEPARTMENT OF TRANSPORTATION	DRAINAGE SCUPPER, DS-33 STRUCTURE NO. 016-0064 AND 016-0065	F.A.I. R.E.	SECTION	COUNTY	TOTAL SHEETS	SHEET NO.	
Default	Plot Scale = 100.0000' / in.	DRAWN -	REVISED -			57	2013-025-1	COOK	23	14	
	PLOT DATE = 9/9/2013	CHECKED -	REVISED -			CONTRACT NO. 60W60					
		DATE -	REVISED -			ILLINOIS FED. AID PROJECT					