

HTC LAYOUT & PLAN NOTATION FOR LIMITED DEFLECTION LOCATION

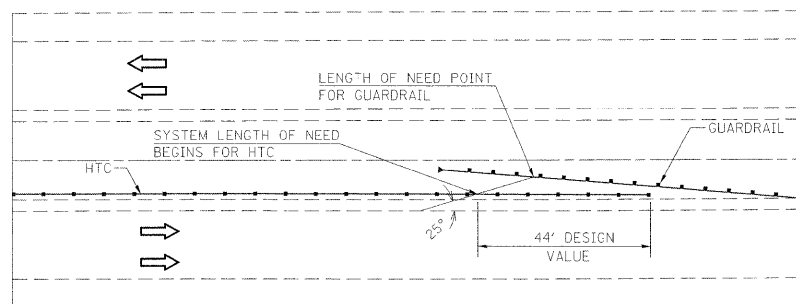

HTC LAYOUT FOR TERMINATION IN FRONT OF FLARED GUARDRAIL

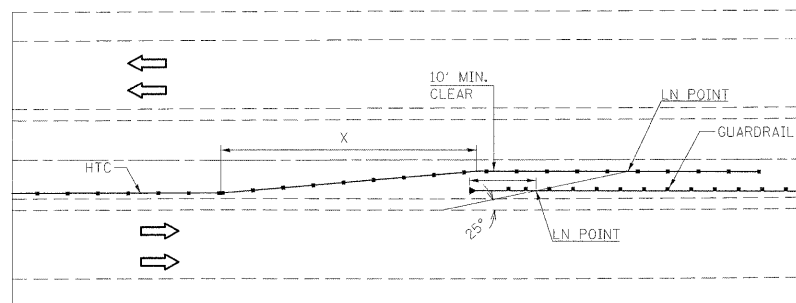

HTC LAYOUT FOR TERMINATION BEHIND TANGENT GUARDRAIL

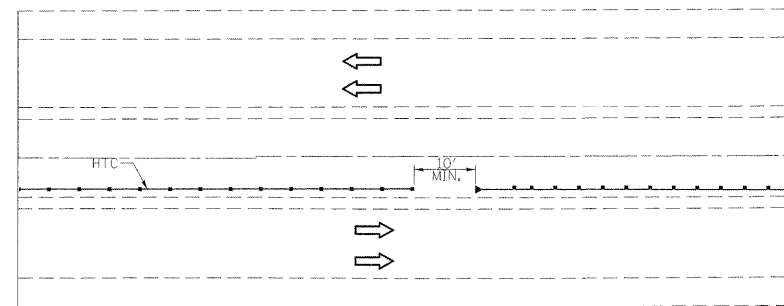

HTC LAYOUT ADJACENT TO GUARDRAIL

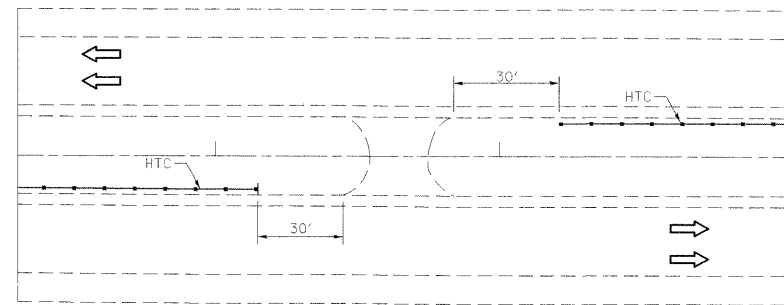

HTC LAYOUT AT MEDIAN CROSSOVERS

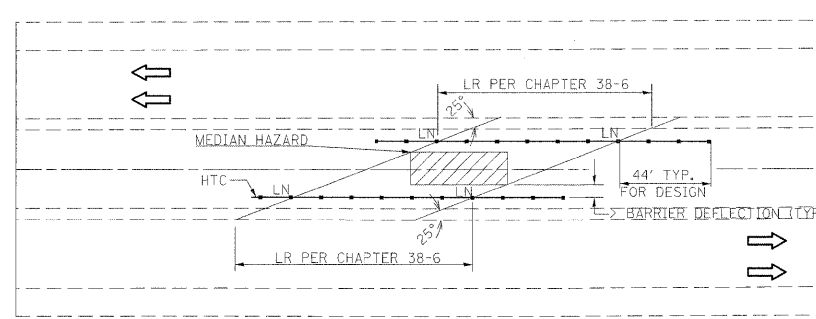

HTC LAYOUT FOR MEDIAN HAZARD PROTECTION

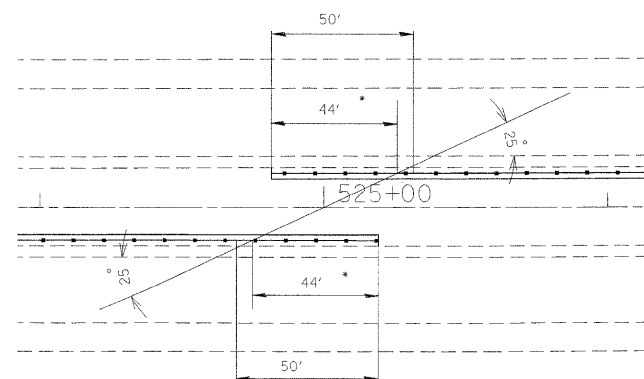

HTC LAYOUT FOR PLACEMENT ON OPPOSITE SIDES

\* FOR PURPOSES OF HTC LAYOUT SHOWN IN PLANS, 44' FOR LON POINT WAS USED. ACTUAL LON POINT WILL VARY DEPENDING ON HTC SYSTEM USED.

PAY LENGTH FOR HTC MEDIAN BARRIER TERMINAL IS 50' REGARDLESS OF LON POINT.

FILE NAME = c:\projects\ed04707\plan\pln04707a.dgn	USER NAME = conoverpj	DESIGNED - ---	REVISED - ---	<b>STATE OF ILLINOIS DEPARTMENT OF TRANSPORTATION</b>	<b>HTC DETAILS</b>			F.A.I. RTE. 55	SECTION 60-(2,3)I	COUNTY MADISON	TOTAL SHEETS 78	SHEET NO. 42
	PLOT SCALE = 50.0000' / 1" =	DRAWN - ---	REVISED - ---		SCALE: _____	SHEET NO. ___ OF ___ SHEETS	STA. _____ TO STA. _____	CONTRACT NO. 76A76				
	PLOT DATE = 7/29/2008	CHECKED - ---	REVISED - ---		FED. ROAD DIST. NO. ILLINOIS FED. AID PROJECT							
		DATE - ---	REVISED - ---									