

|                     |          |                  |              |           |
|---------------------|----------|------------------|--------------|-----------|
| F.A.P. RTE.         | SECTION  | COUNTY           | TOTAL SHEETS | SHEET NO. |
| 607                 | 129 BR   | KENDALL          | 61           | 37        |
| STA.                |          | TO STA.          |              |           |
| FED. ROAD DIST. NO. | ILLINOIS | FED. AID PROJECT |              |           |

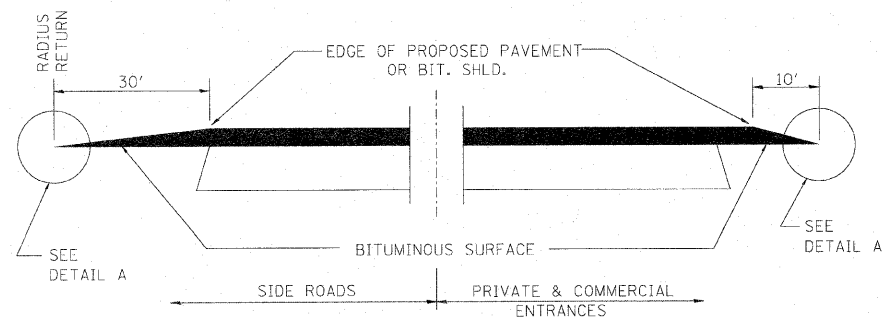

SECTION A-A  
DETAILS AT ENTRANCES & SIDE ROADS

THE COST OF REMOVAL AT EXISTING BIT. OR P.C.C. LOCATIONS SHALL BE PAID FOR PER SQ. YD. BY THE APPROPRIATE PAY ITEM. REMOVAL AT EXISTING AGG. LOCATIONS SHALL BE INCIDENTAL TO THE BITUMINOUS. A-3 LOCATIONS SHALL BE FEATHER TAPERED.

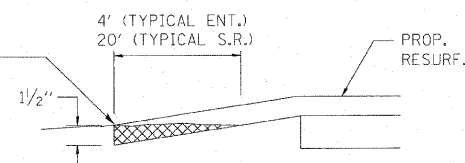

DETAIL A

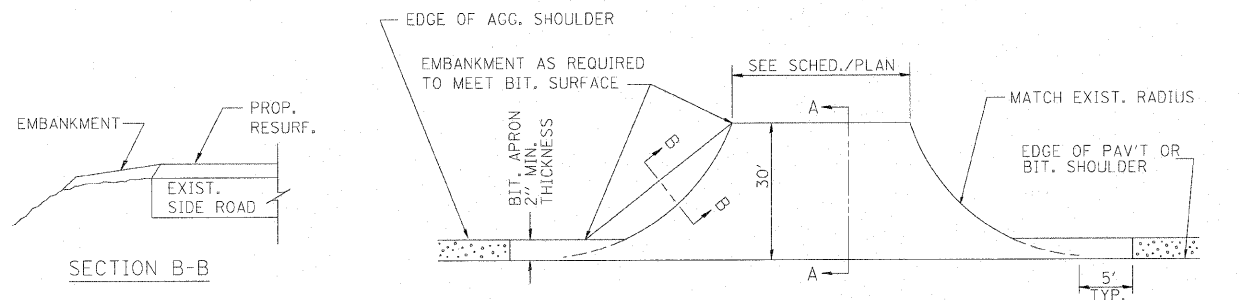

AGG. SHOULDER IS NOT TO BE PLACED AROUND SIDE ROAD RADII

PROP. BIT. SHLD. SHALL NOT BE CONSTRUCTED THRU BIT. CONC. SIDEROADS.

PLAN AT SIDE ROADS

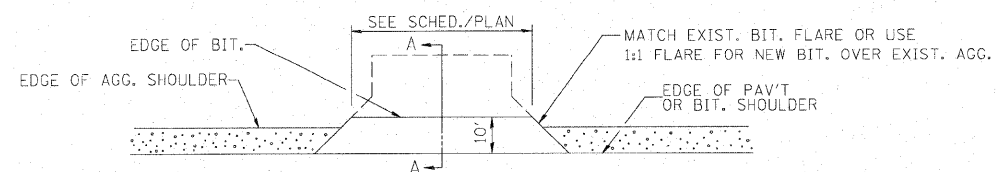

PLAN AT PRIVATE & COMMERCIAL ENTRANCES  
(DO NOT RESURFACE FIELD ENTRANCES)

406-2

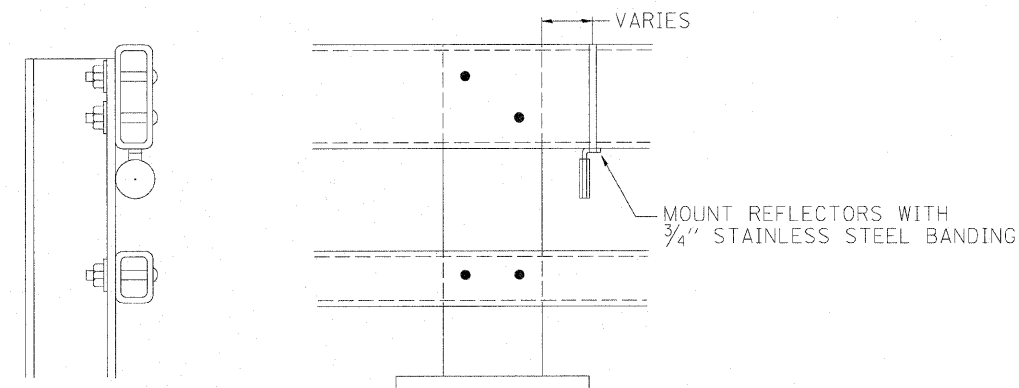

NOTES:

- REFLECTORS SHALL MEET THE REQUIREMENTS OF ARTICLE 1097.03 OF THE STANDARD SPECIFICATIONS.
- FURNISHING AND INSTALLING THE COMPLETE REFLECTOR UNIT WILL BE PAID AT THE CONTRACT UNIT PRICE EACH FOR GUARD RAIL MARKERS.

**REFLECTOR MOUNTING  
DETAIL FOR STEEL RAIL**

630-7

PLOT DATE = 10/17/2007  
FILE NAME = K:\DEPT\116691\1\From Club 12-29-06\DETAIL.dgn  
PLOT SCALE = #SCALE6  
USER NAME = USER

| REVISIONS |      | ILLINOIS DEPARTMENT OF TRANSPORTATION |
|-----------|------|---------------------------------------|
| NAME      | DATE |                                       |
|           |      | DETAILS                               |
|           |      |                                       |
|           |      |                                       |
|           |      |                                       |
|           |      |                                       |
|           |      |                                       |
|           |      |                                       |
|           |      |                                       |
|           |      |                                       |
|           |      |                                       |

SCALE: VERT. NOT TO SCALE  
HORIZ. NOT TO SCALE  
DATE 10/17/2007

DRAWN BY C. SUNTKEN  
CHECKED BY M. ZELINSKAS