

CONTRACT NO.				
F.A. RTE.	SECTION	COUNTY	TOTAL SHEETS	SHEET NO.
08-F3000-20-BT		COOK	29	15
STA.		TO STA.		
FED. ROAD DIST. NO. 1		ILLINOIS FED. AID PROJECT		
CONTRACT NO. 63052				

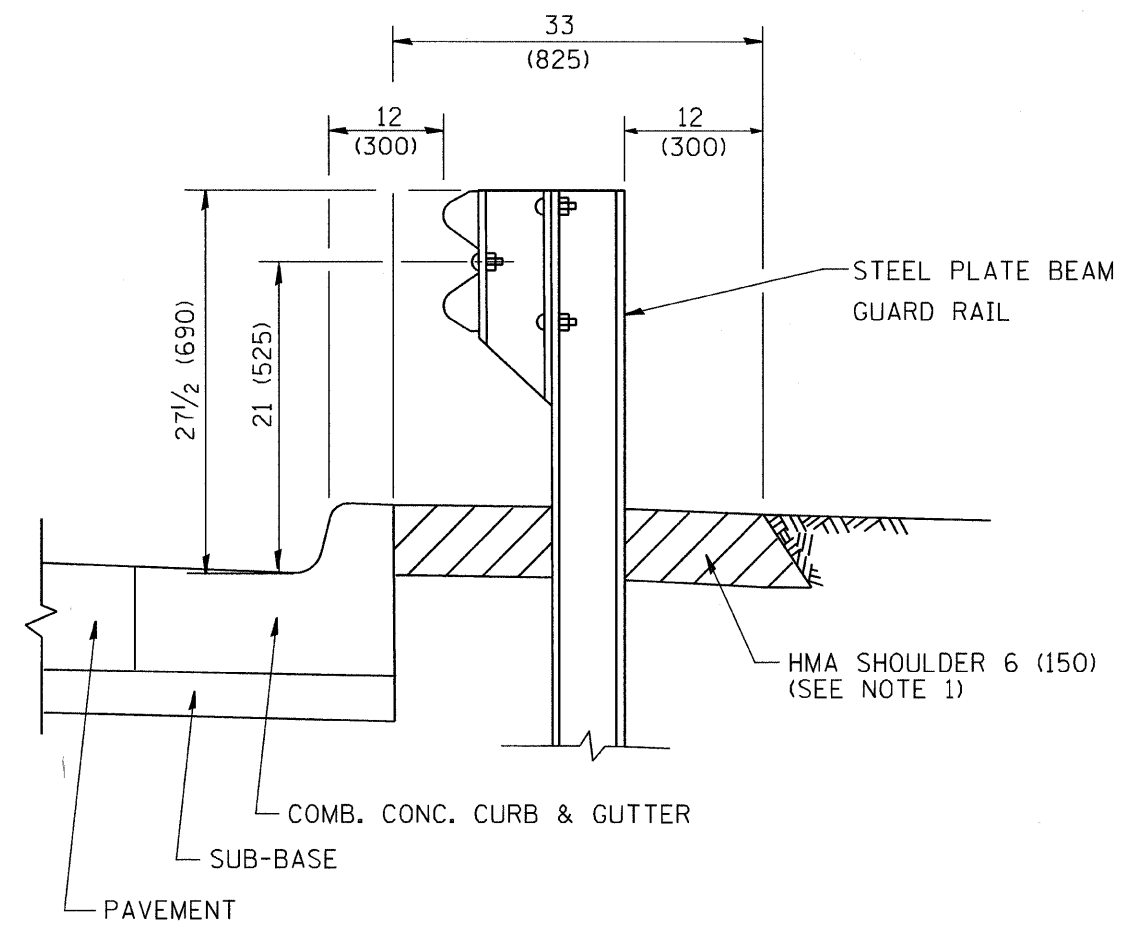

- NOTES: 1. THE HMA SHOULDER SHALL EXTEND UNDER THE TRAFFIC BARRIER TERMINAL
2. GUARD RAIL MAY BE PLACED AT THE BACK OF CURB WHEN DIRECTED BY THE ENGINEER.

BASIS OF PAYMENT: HMA SHOULDER 6 (150) WILL BE PAID FOR AT THE CONTRACT UNIT PRICE PER SQUARE YARD (SQUARE METER) FOR "HOT-MIX ASPHALT SHOULDER 6" (150 mm)".

STEEL PLATE BEAM GUARD RAIL AND TRAFFIC BARRIER TERMINAL, OF THE TYPE SPECIFIED WILL BE PAID FOR SEPARATELY.

DETAILS FOR STEEL PLATE BEAM GUARD RAIL ADJACENT TO CURB AND GUTTER [FOR ROADWAY SPEED 35 MPH (60 kmh) TO 45 MPH (70 kmh)]

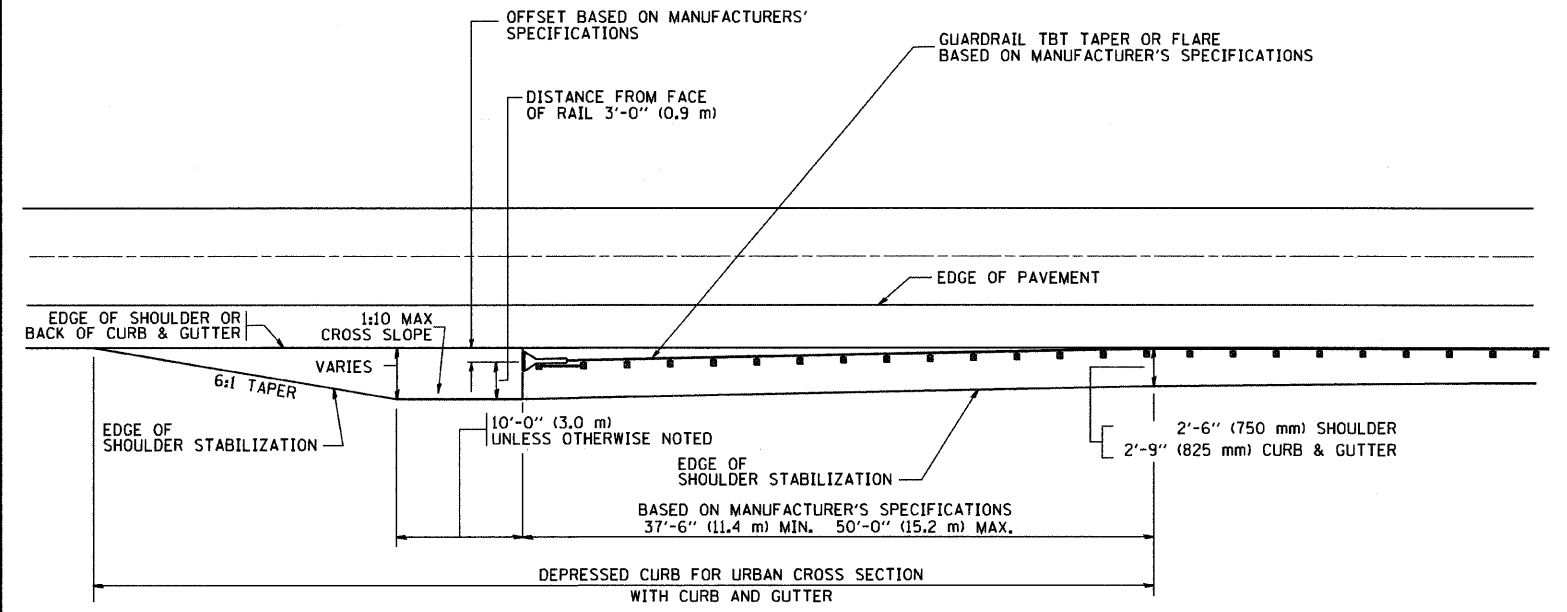

STABILIZATION AT TBT TY. 1 SPL.

TBT = TRAFFIC BARRIER TERMINAL
ALL DIMENSIONS ARE IN INCHES (MILLIMETERS) UNLESS OTHERWISE SHOWN.

REVISIONS	
NAME	DATE
M. DE YONG	09-22-90
M. DE YONG	07-14-92
R. SHAH	09/09/94
R. SHAH	10/25/94
R. SHAH	02/23/95
A. ABBAS	03/21/97
E. GOMEZ	08/28/00
R. BORO	01/01/07

ILLINOIS DEPARTMENT OF TRANSPORTATION

DETAILS FOR STEEL PLATE BEAM GUARD RAIL ADJACENT TO CURB AND GUTTER STABILIZATION AT TBT TY 1 SPL.

SCALE: VERT. NONE
HORIZ. NONE

DRAWN BY jls
CHECKED BY

PLOT DATE = 3/4/2007
FILE NAME = K:\databases\bd34.dgn
PLOT NAME = BD60010 / IN.
USER NAME = bbarndt