

BARRIER & RAILING ELEVATION

(Looking West)
 West Barrier shown
 East Barrier similar

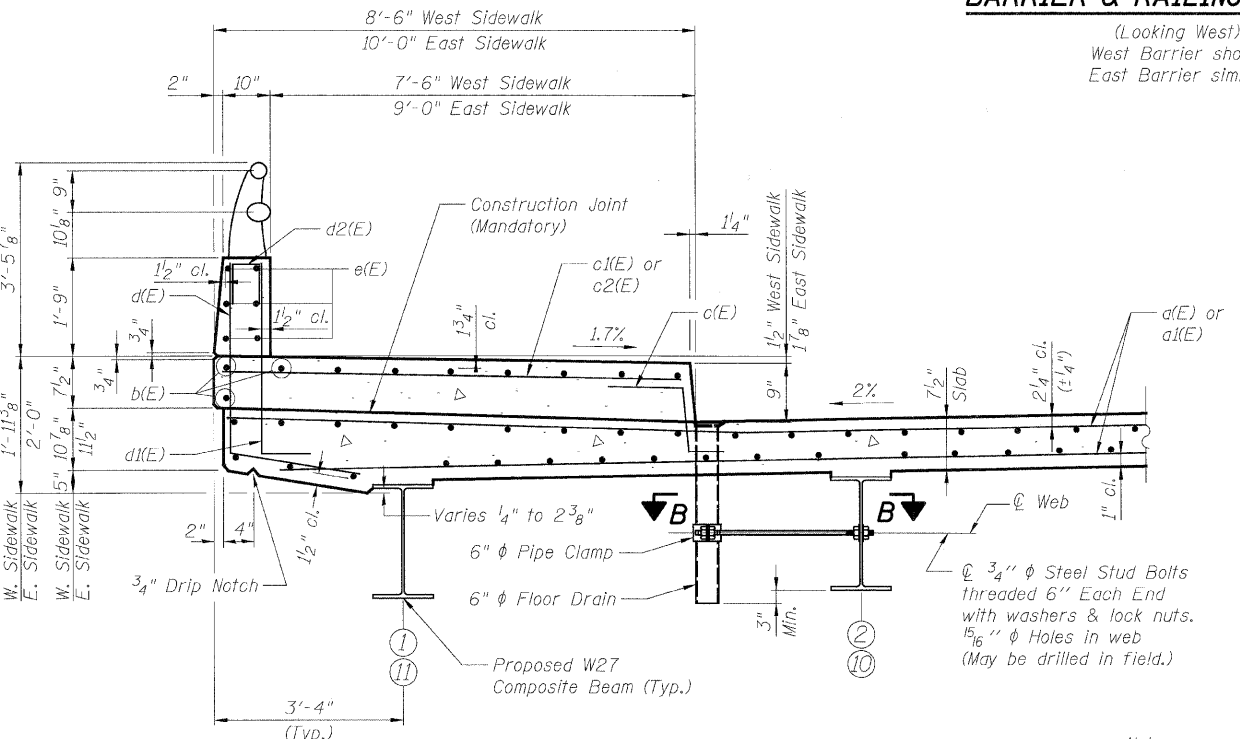

SECTION THRU PARAPET

Notes:
 Fiberglass pipe shall conform to ASTM D 2996, with short-time rupture strength hoop tensile stress of 30,000 p.s.i. minimum.

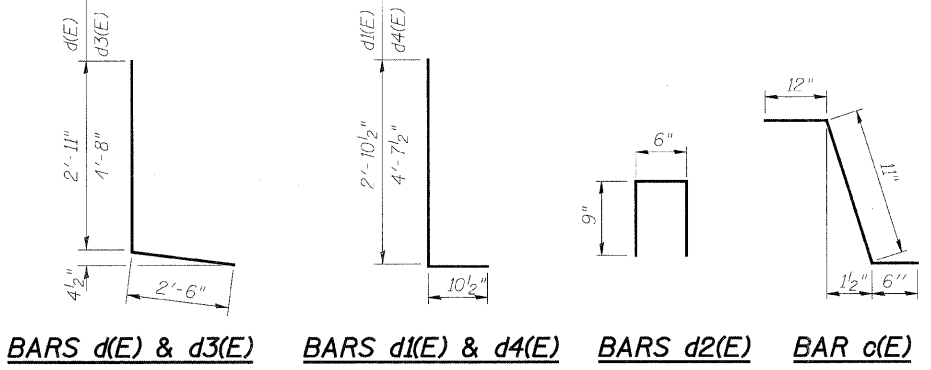

BARS d(E) & d3(E) BARS d1(E) & d4(E) BARS d2(E) BAR c(E)

SUPERSTRUCTURE BILL OF MATERIAL

Bar	No.	Size	Length	Shape
a(E)	217	#5	37'-6"	—
a1(E)	217	#5	49'-0"	—
a2(E)	4	#5	49'-4"	—
a3(E)	4	#5	37'-10"	—
b(E)	222	#5	29'-5"	—
b1(E)	258	#5	20'-2"	—
c(E)	116	#5	2'-5"	—
c1(E)	58	#5	9'-6"	—
c2(E)	58	#5	8'-0"	—
d(E)	101	#4	5'-5"	—
d1(E)	104	#6	3'-9"	—
d2(E)	24	#4	2'-0"	—
d3(E)	20	#4	7'-2"	—
d4(E)	20	#6	5'-6"	—
e(E)	48	#4	14'-1"	—
e1(E)	24	#4	3'-9"	—
m(E)	4	#6	37'-3"	—
m1(E)	12	#6	20'-4"	—
m2(E)	44	#6	10'-11"	—
m3(E)	20	#6	7'-9"	—
m4(E)	4	#6	3'-0"	—
m5(E)	8	#6	25'-9"	—
m6(E)	12	#6	26'-2"	—
s(E)	192	#5	5'-9"	—
s1(E)	178	#4	8'-2"	—
u1(E)	68	#4	2'-7"	—
v(E)	142	#5	4'-6"	—
Concrete Superstructure			Cu. Yd.	209.9
Reinforcement Bars, Epoxy Coated			Lbs.	40,550
Bar Splicers			Each	379
Protective Coat			Sq. Yd.	592
Bridge Deck Grooving			Sq. Yd.	429

* Dimension as required by Pipe Clamp

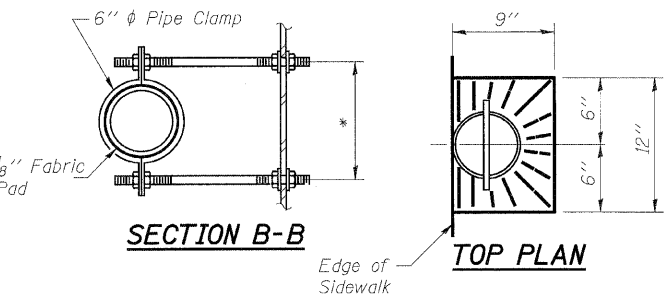

FLOOR DRAIN DETAILS

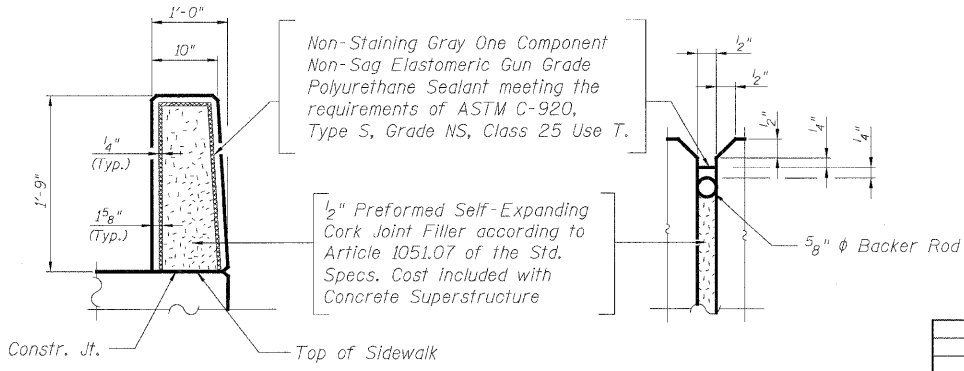

BARRIER JOINT DETAILS

- NOTES:**
1. Bars indicated thus 20 x 3 - #5 etc. indicates 20 lines of bars with 3 lengths per line.
 2. All edges shall have standard 3/4" chamfer, except as noted.

REVISIONS	
NAME	DATE

ILLINOIS DEPARTMENT OF TRANSPORTATION
SUPERSTRUCTURE DETAILS
 ILLINOIS ROUTE 53 OVER
 SPRING BROOK CREEK
 FAU 2578 SECTION 532B-1
 STRUCTURE NO. 022-0189
 DUPAGE COUNTY STATION 166+46.79
 SCALE: NONE DRAWN BY: E. MROCZEK
 DATE: 6/12/09 CHECKED BY: A. YARGICOGU