

09A

Letting September 22, 2023

Notice to Bidders, Specifications and Proposal



**Illinois Department
of Transportation**

Springfield, Illinois 62764

**Contract No. WH017
Whiteside County Airport
Rock Falls, Illinois
Whiteside County
Illinois Project No. SQI-5049
SBG Project No. N/A**



NOTICE TO BIDDERS

- 1. TIME AND PLACE OF OPENING BIDS.** Electronic bids are to be submitted to the electronic bidding system (iCX-Integrated Contractors Exchange). All bids must be submitted to the iCX system prior to 12:00 p.m. on September 22, 2023, at which time the bids will be publicly opened from the iCX SecureVault.
- 2. DESCRIPTION OF WORK.** The proposed improvement is identified and advertised for bids in the Invitation for Bids as:

**Contract No. WH017
Whiteside County Airport
Rock Falls, Illinois
Whiteside County
Illinois Project No. SQI-5049
SBG Project No. N/A**

Rehabilitate Airport Entrance Road and Parking Lot

For engineering information, please contact Travis Strait, P.E. of Crawford, Murphy & Tilly, Inc. at 309.277.6608.

3. INSTRUCTIONS TO BIDDERS.

- (a) This Notice, the invitation for bids, proposal and letter of award shall, together with all other documents in accordance with Article 10-18 of the Illinois Standard Specifications for Construction of Airports (Adopted April 1, 2012), become part of the contract. Bidders are cautioned to read and examine carefully all documents, to make all required inspections, and to inquire or seek explanation of the same prior to submission of a bid.
- (b) State law, and, if the work is to be paid wholly or in part with Federal-aid funds, Federal law requires the bidder to make various certifications as a part of the proposal and contract. By execution and submission of the proposal, the bidder makes the certification contained therein. A false or fraudulent certification shall, in addition to all other remedies provided by law, be a breach of contract and may result in termination of the contract.

- 4. AWARD CRITERIA AND REJECTION OF BIDS.** This contract will be awarded within 90 calendar days to the lowest responsive and responsible bidder considering conformity with the terms and conditions established by the Department in the rules, Invitation for Bids and contract documents. The issuance of plans and proposal forms for bidding based upon a prequalification rating shall not be the sole determinant of responsibility. The Department reserves the right to determine responsibility at the time of award, to reject any or all proposals, to readvertise the proposed improvement, and to waive technicalities.

- 5. PRE-BID CONFERENCE.** N/A

- 6. DISADVANTAGED BUSINESS POLICY.** The DBE goal for this contract is 4.0%.

- 7. SPECIFICATIONS AND DRAWINGS.** The work shall be done in accordance with the Illinois Standard Specifications for Construction of Airports (Adopted April 1, 2012), the Special Provisions dated July 28, 2023, and the Construction Plans dated July 28, 2023 as approved by the Illinois Department of Transportation, Division of Aeronautics.

- 8. BIDDING REQUIREMENTS AND BASIS OF AWARD.** When alternates are included in the proposal, the following shall apply:
- a. Additive Alternates
 - (1) Bidders must submit a bid for the Base Bid and for all Additive Alternates.
 - (2) Award of this contract will be made to the lowest responsible qualified bidder computed as follows:

The lowest aggregate amount of (i) the Base Bid plus (ii) any Additive Alternate(s) which the Department elects to award.

The Department may elect not to award any Additive Alternates. In that case, award will be to the lowest responsible qualified bidder of the Base Bid.
 - b. Optional Alternates
 - (1) Bidders must submit a bid for the Base Bid and for either Alternate A or Alternate B or for both Alternate A and Alternate B.
 - (2) Award of this contract will be made to the lowest responsible qualified bidder computed as follows:

The lower of the aggregate of either (i) the Base Bid plus Alternate A or (ii) the Base Bid plus Alternate B.
- 9. CONTRACT TIME.** The Contractor shall complete all work within the specified contract time. Any calendar day extension beyond the specified contract time must be fully justified, requested by the Contractor in writing, and approved by the Engineer, or be subject to liquidated damages.
- The contract time for this contract is 35 calendar days.
- 10. INDEPENDENT WEIGHT CHECKS.** The Department reserves the right to conduct random unannounced independent weight checks on any delivery for bituminous, aggregate or other pay item for which the method of measurement for payment is based on weight. The weight checks will be accomplished by selecting, at random, a loaded truck and obtaining a loaded and empty weight on an independent scale. In addition, the department may perform random weight checks by obtaining loaded and empty truck weights on portable scales operated by department personnel.
- 11. MATERIAL COST ADJUSTMENTS.** The Illinois Department of Transportation, Division of Aeronautics does not offer any material cost adjustment provisions.
- 12. GOOD FAITH COMPLIANCE.** The Illinois Department of Transportation has made a good faith effort to include all statements, requirements, and other language required by federal and state law and by various offices within federal and state governments whether that language is required by law or not. If anything of this nature has been left out or if additional language etc. is later required, the bidder/contractor shall cooperate fully with the Department to modify the contract or bid documents to correct the deficiency. If the change results in increased operational costs, the Department shall reimburse the contractor for such costs as it may find to be reasonable.

By Order of the
Illinois Department of Transportation

Omer Osman,
Secretary

State of Illinois
Department of Transportation

SPECIAL PROVISION
FOR
EEO

Effective: July 21, 1978
Revised: November 18, 1980

The requirements of the following provisions written for federally-assisted construction contracts, including all goals and timetables and affirmative action steps, shall also apply to all State-funded construction contracts awarded by the Illinois Department of Transportation.

Notice of Requirement for Affirmative Action to Ensure
Equal Employment Opportunity (Executive Order 11246)

1. The offeror's or bidder's attention is called to the "Equal Opportunity Clause" and the "Standard Federal Equal Employment Opportunity Construction Contract Specifications" set forth herein.
2. The goals and timetables for minority and female participation, expressed in percentage terms for the Contractor's aggregate workforce in each trade on all construction work in the covered area, are as follows:

APPENDIX A

The following goal for female utilization in each construction craft and trade shall apply to all Contractors holding Federal and federally assisted construction contracts and subcontracts in excess of \$10,000. The goal is applicable to the Contractor's total on-site construction workforce, regardless of whether or not part of that workforce is performing work on a federal, federally assisted or nonfederally related construction contract or subcontract.

Area Covered (Statewide)

Goals for Women apply nationwide.

GOAL	Goal (percent)
Female Utilization	6.9

APPENDIX B

Until further notice, the following goals for minority utilization in each construction craft and trade shall apply to all Contractors holding federal and federally-assisted construction contracts and subcontracts in excess of \$10,000 to be performed in the respective geographical areas. The goals are applicable to the Contractor's total on-site construction workforce, regardless of whether or not part of that workforce is performing work on a federal, federally-assisted or nonfederally related construction contract or subcontract.

<u>Economic Area</u>	Goal (percent)
056 Paducah, KY: Non-SMSA Counties - IL - Hardin, Massac, Pope KY - Ballard, Caldwell, Calloway, Carlisle, Crittenden, Fulton, Graves, Hickman, Livingston, Lyon, McCracken, Marshall	5.2
080 Evansville, IN: Non-SMSA Counties - IL - Edwards, Gallatin, Hamilton, Lawrence, Saline, Wabash, White IN - Dubois, Knox, Perry, Pike, Spencer KY - Hancock, Hopkins, McLean, Mublenberg, Ohio, Union, Webster	3.5
081 Terre Haute, IN: Non-SMSA Counties - IL - Clark, Crawford IN - Parke	2.5

083	Chicago, IL: SMSA Counties: 1600 Chicago, IL -	19.6
	IL - Cook, DuPage, Kane, Lake, McHenry, Will 3740 Kankakee, IL -	9.1
	IL - Kankakee Non-SMSA Counties	18.4
	IL - Bureau, DeKalb, Grundy, Iroquois, Kendall, LaSalle, Livingston, Putnam	
	IN - Jasper, Laporte, Newton, Pulaski, Starke	
084	Champaign - Urbana, IL: SMSA Counties: 1400 Champaign - Urbana - Rantoul, IL -	7.8
	IL - Champaign Non-SMSA Counties -	4.8
	IL - Coles, Cumberland, Douglas, Edgar, Ford, Piatt, Vermilion	
085	Springfield - Decatur, IL: SMSA Counties: 2040 Decatur, IL -	7.6
	IL - Macon 7880 Springfield, IL -	4.5
	IL - Menard, Sangamon Non-SMSA Counties	4.0
	IL - Cass, Christian, Dewitt, Logan, Morgan, Moultrie, Scott, Shelby	
086	Quincy, IL: Non-SMSA Counties	3.1
	IL - Adams, Brown, Pike	
	MO - Lewis, Marion, Pike, Ralls	
087	Peoria, IL: SMSA Counties: 1040 Bloomington - Normal, IL -	2.5
	IL - McLean 6120 Peoria, IL -	4.4
	IL - Peoria, Tazewell, Woodford Non-SMSA Counties -	3.3
	IL - Fulton, Knox, McDonough, Marshall, Mason, Schuyler, Stark, Warren	
088	Rockford, IL: SMSA Counties: 6880 Rockford, IL -	6.3
	IL - Boone, Winnebago Non-SMSA Counties -	4.6
	IL - Lee, Ogle, Stephenson	
098	Dubuque, IA: Non-SMSA Counties -	0.5
	IL - JoDaviess	
	IA - Atlamakee, Clayton, Delaware, Jackson, Winnesheik	
	WI - Crawford, Grant, Lafayette	
099	Davenport, Rock Island, Moline, IA - IL: SMSA Counties: 1960 Davenport, Rock Island, Moline, IA - IL -	4.6
	IL - Henry, Rock Island IA - Scott Non-SMSA Counties -	3.4
	IL - Carroll, Hancock, Henderson, Mercer, Whiteside IA - Clinton, DesMoines, Henry, Lee, Louisa, Muscatine MO - Clark	

4. The Contractor shall implement the specific affirmative action standards provided in paragraphs 7a through p of these specifications. The goals set forth in the solicitation from which this contract resulted are expressed as percentages of the total hours of employment and training of minority and female utilization the Contractor should reasonably be able to achieve in each construction trade in which it has employees in the covered area. Covered Construction Contractors performing construction work in geographical areas where they do not have a Federal or federally assisted construction contract shall apply the minority and female goals established for the geographical area where the work is being performed. Goals are published periodically in the Federal Register in notice form, and such notices may be obtained from any Office of Federal Contract Compliance Programs office or from Federal procurement contracting officers. The Contractor is expected to make substantially uniform progress toward its goals in each craft during the period specified.
5. Neither the provisions of any collective bargaining agreement, nor the failure by a union with whom the Contractor has a collective bargaining agreement, to refer either minorities or women shall excuse the Contractor's obligations under these specifications, Executive Order 11246, or the regulations promulgated pursuant thereto.
6. In order for the nonworking training hours of apprentices and trainees to be counted in meeting the goals, such apprentices and trainees must be employed by the Contractor during the training period, and the Contractor must have made a commitment to employ the apprentices and trainees at the completion of their training, subject to the availability of employment opportunities. Trainees must be trained pursuant to training programs approved by the U.S. Department of Labor.
7. The Contractor shall take specific affirmative actions to ensure equal employment opportunity. The evaluation of the Contractor's compliance with these specifications shall be based upon its effort to achieve maximum results from its actions. The Contractor shall document these efforts fully, and shall implement affirmative action steps at least as extensive as the following:
 - (a) Ensure and maintain a working environment free of harassment, intimidation, and coercion at all sites, and in all facilities at which the Contractor's employees are assigned to work. The Contractor, where possible, will assign two or more women to each construction project. The Contractor shall specifically ensure that all foremen, superintendents, and other on-site supervisory personnel are aware of and carry out the Contractor's obligation to maintain such a working environment, with specific attention to minority or female individuals working as such sites or in such facilities.
 - (b) Establish and maintain a current list of minority and female recruitment sources, provide written notification to minority and female recruitment sources and to community organizations when the Contractor or its unions have employment opportunities available, and maintain a record of the organizations' responses.
 - (c) Maintain a current file of the names, addresses and telephone numbers of each minority and female off-the-street applicant and minority or female referral from a union, a recruitment source or community organization and of what action was taken with respect to each such individual. If such individual was sent to the union hiring hall for referral and was not referred back to the Contractor by the union or, if referred, not employed by the Contractor, this shall be documented in the file with the reason therefor, along with whatever additional actions the Contractors may have taken.
 - (d) Provide immediate written notification to the Director when the union or unions with which the Contractor has a collective bargaining agreement has not referred to the Contractor a minority person or woman sent by the Contractor, or when the Contractor has other information that the union referral process has impeded the Contractor's efforts to meet its obligations.
 - (e) Develop on-the-job training opportunities and/or participate in training programs for the area which expressly include minorities and women, including upgrading programs and apprenticeship and trainee programs relevant to the Contractor's employment needs, especially those programs funded or approved by the Department of Labor. The Contractor shall provide notice of these programs to the sources compiled under 7b above.
 - (f) Disseminate the Contractor's EEO policy by providing notice of the policy to unions and training programs and requesting their cooperation in assisting the Contractor in meeting its EEO obligations; by including it in any policy manual and collective bargaining agreements; by publicizing it in the company newspaper, annual report, etc.; by specific review of the policy with all management personnel and with all minority and female employees at least once a year; and by posting the company EEO policy on bulletin boards accessible to all employees at each location where construction work is performed.
 - (g) Review, at least annually, the company's EEO policy and affirmative action obligations under these specifications with all employees having any responsibility for hiring, assignment, layoff, termination or other employment decisions including specific review of these items with onsite supervisory personnel such as Superintendents, General Foreman, etc., prior to the initiation of construction work at any job site. A written record shall be made and maintained identifying the time and place of these meetings, persons attending, subject matter discussed, and disposition of the subject matter.
 - (h) Disseminate the Contractor's EEO policy externally by including it in any advertising in the news media, specifically including minority and female news media, and providing written notification to and discussing the Contractor's EEO policy with other Contractors and Subcontractors with whom the Contractor does or anticipates doing business.
 - (i) Direct its recruitment efforts, both oral and written, to minority, female and community organizations, to schools with minority and female students and to minority and female recruitment and training organizations serving the Contractor's recruitment area and employment needs. Not later than one month prior to the date for the acceptance of applications for apprenticeship or other training by any recruitment source, the Contractor shall send written notification to organizations such as the above, describing the openings, screening procedures, and tests to be used in the selection process.
 - (j) Encourage present minority and female employees to recruit other minority persons and women and, where reasonable, provide after school, summer and vacation employment to minority and female youth both on the site and in other areas of a Contractor's workforce.
 - (k) Validate all tests and other selection requirements where there is an obligation to do so under 41 CFR Part 60-3.

- (l) Conduct, at least annually, an inventory and evaluation at least of all minority and female personnel for promotional opportunities and encourage these employees to seek or to prepare for, through appropriate training, etc., such opportunities.
 - (m) Ensure that seniority practices, job classifications, work assignments and other personnel practices, do not have a discriminatory effect by continually monitoring all personnel and employment related activities to ensure that the EEO policy and the Contractor's obligations under these specifications are being carried out.
 - (n) Ensure that all facilities and company activities are nonsegregated except that separate or single-user toilet and necessary changing facilities shall be provided to assure privacy between the sexes.
 - (o) Document and maintain a record of all solicitations of offers for subcontracts from minority and female construction Contractors and suppliers, including circulation of solicitations to minority and female Contractor associations and other business associations.
 - (p) Conduct a review, at least annually, of all supervisors' adherence to and performance under the Contractor's EEO policies and affirmative action obligations.
8. Contractors are encouraged to participate in voluntary associations which assist in fulfilling one or more of their affirmative action obligations (7a through p). The efforts of a Contractor association, joint Contractor-union, Contractor-community, or other similar group of which the Contractor is a member and participant, may be asserted as fulfilling any one or more of its obligations under 7a through p of these Specifications provided that the Contractor actively participates in the group, makes every effort to assure that the group has a positive impact on the employment of minorities and women in the industry, ensures that the concrete benefits of the program are reflected in the Contractor's minority and female workforce participation makes a good faith effort to meet its individual goals and timetables, and can provide access to documentation which demonstrates the effectiveness of actions taken on behalf of the Contractor. The obligation to comply, however, is the Contractor's and failure of such a group to fulfill an obligation shall not be a defense for the Contractor's noncompliance.
9. A single goal for minorities and a separate single goal for women have been established. The Contractor, however, is required to provide equal employment opportunity and to take affirmative action for all minority groups, both male and female, and all women, both minority and non-minority. Consequently, the Contractor may be in violation of the Executive Order if a particular group is employed in a substantially disparate manner (for example, even though the Contractor has achieved its goals for women generally, the Contractor may be in violation of the Executive Order if a specified minority group of women is underutilized).
10. The Contractor shall not use the goals and timetables or affirmative action standards to discriminate against any person because of race, color, religion, sex, or national origin.
11. The Contractor shall not enter into any Subcontract with any person or firm debarred from Government contracts pursuant to Executive Order 11246.
12. The Contractor shall carry out such sanctions and penalties for violation of these specifications and of the Equal Opportunity Clause, including suspension, termination and cancellation of existing subcontracts as may be imposed or ordered pursuant to Executive Order 11246, as amended, and its implementing regulations, by the Office of Federal Contract Compliance Programs. Any Contractor who fails to carry out such sanctions and penalties shall be in violation of these specifications and Executive Order 11246, as amended.
13. The Contractor, in fulfilling its obligations under these specifications, shall implement specific affirmative action steps, at least as extensive as those standards prescribed in paragraph 7 of these specifications, so as to achieve maximum results from its efforts to ensure equal opportunity. If the Contractor fails to comply with the requirements of the Executive Order, the implementing regulations, or these specifications, the Director shall proceed in accordance with 41 CFR 60-4.8.
14. The Contractor shall designate a responsible official to monitor all employment related activity to ensure that the company EEO policy is being carried out, to submit reports relating to the provisions hereof as may be required by the Government and to keep records. Records shall at least include for each employee the name, address, telephone numbers, construction trade, union affiliation if any, employee identification number when assigned, social security number, race, sex, status (e.g., mechanic, apprentice, trainee, helper, or laborer), dates of changes in status, hours worked per week in the indicated trade, rate of pay, and locations at which the work was performed. Records shall be maintained in an easily understandable and retrievable form; however, to the degree that existing records satisfy his requirement, Contractors shall not be required to maintain separate records.
15. Nothing herein provided shall be construed as a limitation upon the application of other laws which establish different standards of compliance or upon the application of requirements for the hiring of local or other area residents (e.g., those under the Public Works Employment Act of 1977 and the Community Development Block Grant Program).

State of Illinois
Department of Transportation

SPECIAL PROVISION
FOR
SPECIFIC EQUAL EMPLOYMENT OPPORTUNITY RESPONSIBILITIES
NONFEDERAL-AID CONTRACTS

Effective: March 20, 1969
Revised: January 1, 1994

1. General

- a. The requirements set forth herein shall constitute the specific affirmative action requirements under this contract and supplement the non-discrimination requirements contained elsewhere in this proposal.
- b. The Contractor shall work with the Illinois Department of Transportation (IDOT) in carrying out Equal Employment Opportunity (EEO) obligations and in reviews of activities under the contract.
- c. The Contractor, and all subcontractors holding subcontracts (not including material suppliers) of \$10,000 or more, shall comply with the following minimum specific requirement activities of EEO. The Contractor shall include these requirements in every subcontract of \$10,000 or more with such modification of language as is necessary to make them binding on the subcontractor.

2. Equal Employment Opportunity Policy

The Contractor shall accept as operating policy the following statement which is designed to further the provision of EEO to all persons, and to promote the full realization of equal employment opportunity through a positive continuing program: "It is the policy of this Company to ensure that applicants are employed, and that employees are treated during employment, without regard to their race, religion, sex, color, national origin, age, or disability. Such action shall include: employment, upgrading, demotion, or transfer; recruitment or recruitment advertising; layoff or termination; rates of pay or other forms of compensation; and selection for training, including apprenticeship, pre-apprenticeship, and/or on-the-job training."

3. Equal Employment Opportunity Officer

The Contractor shall designate and make known to IDOT contracting officers an EEO Officer who will have the responsibility for and must be capable of effectively administering and promoting an active Contractor program of EEO and who must be assigned adequate authority and responsibility to do so.

4. Dissemination of Policy

- a. All members of the Contractor's staff who are authorized to hire, supervise, promote, and discharge employees, or who recommend such action, or who are substantially involved in such action, will be made fully cognizant of, and will implement, the Contractor's EEO policy and contractual responsibilities to provide EEO in each grade and classification of employment. To ensure that the above agreement will be met, the following actions will be taken as a minimum:
 - (1) Periodic meetings of supervisory and personnel office employees will be conducted before the start of work and then not less often than once every six months, at which time the Contractor's EEO policy and its implementation will be reviewed and explained. The meetings will be conducted by the EEO Officer.
 - (2) All new supervisory or personnel office employees will be given a thorough indoctrination by the EEO Officer, covering all major aspects of the Contractor's EEO obligations within thirty days following their reporting for duty with the Contractor.
 - (3) All personnel who are engaged in direct recruitment for the project will be instructed by the EEO Officer in the Contractor's procedures for locating and hiring minority and female employees.
- b. In order to make the Contractor's EEO policy known to all employees, prospective employees, and potential sources of employees, i.e., schools, employment agencies, labor unions (where appropriate), college placement officers, etc., the Contractor shall take the following actions:
 - (1) Notices and posters setting forth the Contractor's EEO policy will be placed in areas readily accessible to employees, applicants for employment and potential employees.
 - (2) The Contractor's EEO policy and the procedures to implement such policy shall be brought to the attention of employees by means of meetings, employee handbooks, or other appropriate means.

5. Recruitment

- a. When advertising for employees, the Contractor shall include in all advertisements for employees the notation: "An Equal Opportunity Employer". All such advertisements shall be published in newspapers, or other publications, having a large circulation among minority groups in the area from which the project work force would normally be derived.
- b. The Contractor shall, unless precluded by a valid bargaining agreement, conduct systematic and direct recruitment through public and private employee referral sources likely to yield qualified minority and female applicants, including, but not limited to, State employment

agencies, schools, colleges and minority and female organizations. To meet this requirement, the Contractor shall, identify sources of potential minority and female employees, and establish with such identified sources procedures whereby minority and female applicants may be referred to the Contractor for employment consideration. In the event the Contractor has a valid bargaining agreement providing for exclusive hiring hall referrals, he/she is expected to observe the provisions of that agreement to the extent that the system permits the Contractor's compliance with EEO contract provisions.

- c. The Contractor shall encourage present employees to refer minority and female applicants for employment by posting appropriate notices or bulletins in areas accessible to all such employees. In addition, information and procedures with regard to referring minority and female applicants shall be discussed with employees.

6. Personnel Actions

Wages, working conditions, and employee benefits shall be established and administered, and personnel actions of every type, including hiring, upgrading, promotion, transfer, demotion, layoff, and termination, will be taken without regard to race, color, religion, sex, national origin, age, or disability. The following procedures shall be followed:

- a. The Contractor shall conduct periodic inspections of project sites to insure that working conditions and employee facilities do not indicate discriminatory treatment of project site personnel.
- b. The Contractor shall periodically evaluate the spread of wages paid within each classification to determine any evidence of discriminatory wage practices.
- c. The Contractor shall periodically review selected personnel actions in depth to determine whether there is evidence of discrimination. Where evidence is found, the Contractor shall promptly take corrective action. If the review indicates that the discrimination may extend beyond the actions reviewed, such corrective action shall include all affected persons.
- d. The Contractor shall promptly investigate all complaints of alleged discrimination made to the Contractor in connection with the obligations under this contract, shall attempt to resolve such complaints, and shall take appropriate corrective action within a reasonable time. If the investigation indicates that the discrimination may affect persons other than the complainant, such corrective action shall include such other persons. Upon completion of each investigation, the Contractor shall inform every complainant of all of the avenues of appeal.

7. Training and Promotion

- a. The Contractor shall assist in locating, qualifying and increasing the skills of minority and female employees and applicants for employment.
- b. Consistent with the Contractor's work force requirements and as permissible under Federal and State regulations, the Contractor shall make full use of training programs, i.e., apprenticeship, and on-the-job training programs for the geographical area of contract performance.
- c. The Contractor shall advise employees and applicants for employment of available training programs and entrance requirements for each.
- d. The Contractor shall periodically review the training and promotion potential of minority and female employees and shall encourage eligible employees to apply for such training and promotion.

8. Unions

If the Contractor relies in whole or in part upon unions as a source of employees, the Contractor shall use his/her best efforts to obtain the cooperation of such unions to increase opportunities for minorities and females within the unions, and to effect referrals by such unions of minority and female employees. Actions by the Contractor, either directly or through a Contractor's association acting as agent, shall include the procedures set forth below:

- a. The Contractor shall use best efforts to develop, in cooperation with the unions, joint training programs aimed toward qualifying more minority and female employees for membership in the unions and increasing the skills of minority and female and employees so that they may qualify for higher paying employment.
- b. The Contractor shall use best efforts to incorporate an EEO clause into each union agreement to the end that such union shall be contractually bound to refer applicants without regard to their race, color, religion, sex, national origin, age, or disability.
- c. The Contractor is to obtain information as to the referral practices and policies of the labor union, except that to the extent such information is within the exclusive possession of the labor union and such labor union refuses to furnish such information to the Contractor, the Contractor shall so certify to IDOT and shall set forth what efforts have been made to obtain such information.
- d. In the event the union is unable to provide the Contractor with a reasonable flow of minority and female referrals within the time limit set forth in the collective bargaining agreement, the Contractor shall, through independent recruitment efforts, fill the employment vacancies without regard to race, color, religion, sex, national origin, age, or disability; making full efforts to obtain qualified and/or qualifiable minorities and females. (The U.S. Department of Labor has held that it shall be no excuse that the union with which the Contractor has a collective bargaining agreement providing for exclusive referral failed to refer minorities or female employees). In the event the union referral practice prevents the Contractor from meeting the obligations pursuant to these Special Provisions, such Contractor shall immediately notify IDOT.

9. Selection of Subcontractors, Procurement of Materials, and Leasing of Equipment

The Contractor shall not discriminate on the grounds of race, color, religion, sex, national origin, age, or disability in the selection and retention of subcontractors, including procurement of materials and leases of equipment.

- a. The Contractor shall notify all potential subcontractors and suppliers of his/her EEO obligations under this contract.
- b. Disadvantaged business enterprises (DBE), as defined in 49 CFR Part 23, shall have equal opportunity to compete for and perform subcontracts which the Contractor enters into pursuant to this contract. The Contractor shall use best efforts to solicit bids from and to utilize DBE subcontractors or subcontractors with meaningful minority and female representation among their employees. Contractors shall obtain lists of DBE construction firms from IDOT personnel.
- c. The Contractor shall use his/her best efforts to ensure subcontractor compliance with their EEO obligations.

10. Records and Reports

The Contractor shall keep such records as necessary to document compliance with the EEO requirements. Such records shall be retained for a period of three years following completion of the contract work and shall be available at reasonable times and places for inspection by authorized representatives of IDOT.

- a. The records kept by the Contractor shall document the following:
 - (1) the number of minorities, non-minorities and females employed in each work classification on the project;
 - (2) the progress and efforts being made in cooperation with unions, when applicable, to increase employment opportunities for minorities and females;
 - (3) the progress and efforts being made in locating, hiring, training, qualifying, and upgrading minority and female employees; and
 - (4) the progress and efforts being made in securing the services of DBE subcontractors, or subcontractors with meaningful minority and female representation among their employees.
- b. The Contractor shall submit to IDOT a monthly report every month for the duration of the project, indicating the number of minority, non-minority and female employees currently engaged in each work classification required by contract work and the number of hours worked. This information is to be reported on Form SBE-956. If on-the-job training is being required by special provision, the Contractor will be required to collect and report training data.

State of Illinois
Department of Transportation

SPECIAL PROVISION
FOR
REQUIRED PROVISIONS – STATE CONTRACTS

Effective: April 1 1965
Revised: January 1, 2017

I. SELECTION OF LABOR

The Contractor shall comply with all Illinois statutes pertaining to the selection of labor.

EMPLOYMENT OF ILLINOIS WORKERS DURING PERIODS OF
EXCESSIVE UNEMPLOYMENT

Whenever there is a period of excessive unemployment in Illinois, which is defined herein as any month immediately following two consecutive calendar months during which the level of unemployment in the State of Illinois has exceeded five percent as measured by the United States Bureau of Labor Statistics in its monthly publication of employment and unemployment figures, the Contractor shall employ at least 90 percent Illinois laborers. "Illinois laborer" means any person who has resided in Illinois for at least 30 days and intends to become or remain an Illinois resident.

Other laborers may be used when Illinois laborers as defined herein are not available, or are incapable of performing the particular type of work involved, if so certified by the Contractor and approved by the Engineer. The Contractor may place no more than three of his/her regularly employed non-resident executive and technical experts, who do not qualify as Illinois laborers, to do work encompassed by this Contract during period of excessive unemployment.

This provision applies to all labor, whether skilled, semi-skilled, or unskilled, whether manual or non-manual.

II. EQUAL EMPLOYMENT OPPORTUNITY

In the event of the Contractor's noncompliance with the provisions of this Equal Employment Opportunity Clause, the Illinois Human Rights Act or the Illinois Department of Human Rights Rules and Regulations, the Contractor may be declared ineligible for future contracts or subcontracts with the State of Illinois or any of its political sub-divisions or municipal corporations, and the contract may be cancelled or voided in whole or in part, and such other sanctions or penalties may be imposed or remedies invoked as provided by statute or regulation.

During the performance of this Contract, the Contractor agrees as follows:

1. That it will not discriminate against any employee or applicant for employment because of race, color, religion, sex, sexual orientation, marital status, order of protection status, national origin or ancestry, citizenship status, age, physical or mental disability unrelated to ability, military status, or an unfavorable discharge from military service; and further that it will examine all job classifications to determine if minority persons or women are underutilized and will take appropriate affirmative action to rectify any such underutilization.
2. That, if it hires additional employees in order to perform this contract or any portion hereof, it will determine the availability (in accordance with the Illinois Department of Human Rights Rules and Regulations) of minorities and women in the area(s) from which it may reasonably recruit and it will hire for each job classification for which employees are hired in such a way that minorities and women are not underutilized.
3. That, in all solicitations or advertisements for employees placed by it or on its behalf, it will state that all applicants will be afforded equal opportunity without discrimination because of race, color, religion, sex, sexual orientation, marital status, order of protection status, national origin or ancestry, citizenship status, age, physical or mental disability unrelated to ability, military status, or an unfavorable discharge from military service.
4. That it will send to each labor organization or representative of workers with which it has or is bound by a collective bargaining or other agreement or understanding, a notice advising such labor organization or representative of the Contractor's obligations under the Illinois Human Rights Act and the Illinois Department of Human Rights Rules and Regulations. If any labor organization or representative fails or refuses to cooperate with the Contractor in its efforts to comply with such Act and Rules and Regulations, the Contractor will promptly so notify the Illinois Department of Human Rights and IDOT and will recruit employees from other sources when necessary to fulfill its obligations thereunder.
5. That it will submit reports as required by the Illinois Department of Human Rights Rules and Regulations, furnish all relevant information as may from time to time be requested by the Illinois Department of Human Rights or IDOT, and in all respects comply with the Illinois Human Rights Act and the Illinois Department of Human Rights Rules and Regulations.
6. That it will permit access to all relevant books, records, accounts and work sites by personnel of IDOT and the Illinois Department of Human Rights for purposes of investigation to ascertain compliance with the Illinois Human Rights Act and the Illinois Department of Human Rights Rules and Regulations.
7. That it will include verbatim or by reference the provisions of this clause in every subcontract it awards under which any portion of the contract obligations are undertaken or assumed, so that the provisions will be binding upon the subcontractor. In the same manner as with other provisions of this contract, the Contractor will be liable for compliance with applicable provisions of this clause by subcontractors; and further it will promptly notify IDOT and the Illinois Department of Human Rights in the event any subcontractor fails or refuses to comply with these provisions. In addition, the Contractor will not utilize any subcontractor declared by the Illinois Human Rights Commission to be ineligible for contracts or subcontracts with the State of Illinois or any of its political subdivisions or municipal corporations.

III. SUBLETTING OR ASSIGNING THE CONTRACT

1. The Contractor shall perform with his/her own organization contract work amounting to not less than 51 percent of the original total contract price, except that any items designated by the State as "Specialty Items" may be performed by subcontract and the amount of any such "Specialty Items" so performed may be deducted from the original total contract price before computing the amount of work required to be performed by the Contractor with his/her own organization.
 - a. "His/her own organization" shall be construed to include only worker employed and paid directly by the Contractor and equipment owned or rented by him/her, with or without operators.
 - b. "Specialty Items" shall be construed to be limited to work that requires specialized knowledge, craftsmanship or equipment not ordinarily available in contracting organizations qualified to bid on the contract as a whole and in general are to be limited to minor components of the overall contract.
2. In addition to the 51 percent requirement set forth in paragraph 1 above, the Contractor shall furnish (a) a competent superintendent or foreman who is employed by him/her, who has full authority to direct performance of the work in accordance with the contract requirements, and who is in charge of all construction operations (regardless of who performs the work), and (b) such other of his/her own organizational capability and responsibility (supervision, management, and engineering services) as the State highway department contracting officer determines is necessary to assure the performance of the contract.
3. The Contractor shall not sublet, sell, transfer, assign or otherwise dispose of the contract or contracts or any portion thereof, or of his/her right, title or interest therein, without written consent of the Engineer. In case such consent is given, the Contractor will be permitted to sublet a portion thereof, but shall perform with the Contractor's own organization, work amounting to not less than 51 percent of the total contract cost, except that any items designated in the contract as "specialty items" may be performed by subcontract and the cost of any such specialty items so performed by subcontract may be deducted from the total cost before computing the amount of work required to be performed by the Contractor with his/her own organization. Materials purchased or produced by the Contractor must be incorporated into the project by the Contractor's own organization if their cost is to be applied to the 50 percent requirement.

No subcontracts, or transfer of contract, shall in any case release the Contractor of his/her liability under the contract and bonds. All transactions of the Engineer shall be with the Contractor. The Contractor shall have representative on the job at all times when either contract or subcontract work is being performed.

All requests to subcontract shall contain a certification that the subcontract agreement exists in writing and physically contains the required Federal and State Equal Employment Opportunity provisions and Labor compliance provisions, including the contract minimum wage requirements. The Contractor shall permit Department or Federal representatives to examine the subcontract agreements upon notice.

4. Any items that have been selected as "Specialty Items" for the contract are listed as such in the Special Provisions, bid schedule, or elsewhere in the contract documents.
5. No portion of the contract shall be sublet, assigned or otherwise disposed of, except with the written consent of the State highway department contracting officer, or his/her authorized representative, and such consent when given shall not be construed to relieve the Contractor of any responsibility for the fulfillment of the contract. Request for permission to sublet, assign or otherwise dispose of any portion of the contract shall be in writing and accompanied by (a) a showing that the organization which will perform the work is particularly experienced and equipped for such work, and (b) an assurance by the Contractor that the labor standards provisions set forth in this contract shall apply to labor performed on all work encompassed by the request.

IV. COMPLIANCE WITH THE PREVAILING WAGE ACT

1. **Prevailing Wages.** All wages paid by the Contractor and each subcontractor shall be in compliance with The Prevailing Wage Act (820 ILCS 130), as amended, except where a prevailing wage violates a federal law, order, or ruling, the rate conforming to the federal law, order, or ruling shall govern. The Contractor shall be responsible to notify each subcontractor of the wage rates set forth in this contract and any revisions thereto. If the Department of Labor revises the wage rates, the Contractor will not be allowed additional compensation on account of said revisions. Current wage rate information shall be obtained by visiting the Department of Labor website at <http://www.illinois.gov/idol/Pages/default.aspx>. It is the responsibility of the Contractor to review the rates applicable to the work of this contract at regular intervals in order to insure the timely payment of current rates. Provision of this information to the Contractor by means of the Department of Labor website satisfies the notification of revisions by the Department to the Contractor pursuant to the Act, and the Contractor agrees that no additional notice is required.
2. **Payroll Records.** The Contractor and each subcontractor shall make and keep, for a period of three years from the later of the date of final payment under the contract or completion of the contract, records of the wages paid to his/her workers. The payroll records shall include each worker's name, address, telephone number, social security number, classification, rate of pay, number of hours worked each day, starting and ending times of work each day, total hours worked each week, itemized deductions made, and actual wages paid. Upon seven business days' notice, these records shall be available at a location within the State, during reasonable hours, for inspection by the Department or the Department of Labor; and Federal, State, or local law enforcement agencies and prosecutors.
3. **SUBMISSION OF PAYROLL RECORDS (BDE)**

Effective: April 1, 2021
Revised: November 1, 2022

Submission of Payroll Records. The Contractor and each subcontractor shall, no later than the 15th day of each calendar month, file a certified payroll for the immediately preceding month to the Illinois Department of Labor (IDOL) through the Illinois Prevailing Wage Portal in compliance with the State Prevailing Wage Act (820 ILCS 130). The portal can be found on the IDOL website at <https://www2.illinois.gov/idol/Laws-Rules/CONMED/Pages/Prevailing-Wage-Portal.aspx>. Payrolls shall be submitted in the format prescribed by the IDOL.

In addition to filing certified payroll(s) with the IDOL, the Contractor and each subcontractor shall certify and submit payroll records to the Department each week from the start to the completion of their respective work, except that full social security numbers shall not be included on weekly submittals. Instead, the payrolls shall include an identification number for each employee (e.g., the last four digits of the employee's social security number). In addition, starting and ending times of work each day may be omitted from the payroll records submitted. The submittals shall be made using LCPTracker Pro software. The software is web-based and can be accessed at <https://lcptracker.com/>. When there has been no activity during a work week, a payroll record shall still be submitted with the appropriate option ("No Work", "Suspended", or "Complete") selected."

4. Employee Interviews. The Contractor and each subcontractor shall permit his/her employees to be interviewed on the job, during working hours, by compliance investigators of the Department or the Department of Labor.

V. NONSEGREGATED FACILITIES

(Applicable to State Financed Construction Contracts and related subcontracts exceeding \$10,000 which are not exempt from the Equal Opportunity clause).

By submission of this bid, the execution of this contract or subcontract, or the consummation of this material supply agreement, as appropriate, the bidder, construction Contractor, subcontractor, or material supplier, as appropriate, certifies that (s)he does not maintain or provide for his/her employees any segregated facilities at any of his/her establishments, and that (s)he does not permit his/her employees to perform their services at any location, under his/her control, where segregated facilities are maintained. (S)He certifies further that (s)he will not maintain or provide for his/her employees any segregated facilities at any of his/her establishments, and that (s)he will not permit his/her employees to perform their services at any location, under his/her control, where segregated facilities are maintained. (S)He agrees that a breach of this certification is a violation of the Equal Opportunity clause in this contract. As used in this certification, the term "segregated facilities" means any waiting rooms, work areas, restrooms and washrooms, restaurants and other eating areas, time clocks, locker rooms and other storage or dressing areas, parking lots, drinking fountains, recreation or entertainment areas, transportation, and housing facilities provided for employees which are segregated by explicit directive or are in fact segregated on the basis of race, creed, color, or national origin, because of habit, local custom, or otherwise. (S)He agrees that (except where he/she has obtained identical certifications from proposed subcontractors and material suppliers for specific time periods), he/she will obtain identical certifications from proposed subcontractors or material suppliers prior to the award of subcontracts or the consummation of material supply agreements, exceeding \$10,000 which are not exempt from the provisions of the Equal Opportunity clause, and that (s)he will retain such certifications in his/her files.

State of Illinois
Department of Transportation

SPECIAL PROVISION
FOR
SECTION 80 PROSECUTION AND PROGRESS

This Special Provision amends the provisions of the Standard Specifications for Construction of Airports, adopted April 1, 2012 and shall be construed to be a part thereof, superseding any conflicting provisions thereof applicable to the work under the contract.

80-09 FAILURE TO COMPLETE ON TIME.

DELETE: "See contract documents for current schedule of deductions."

ADD:

Schedule of Deductions for Each Day of Overrun in Contract Time			
Original Contract Amount		Daily Charges	
From More Than	To and Including	Calendar Day	Work Day
\$ 0	\$ 100,000	\$ 475	\$ 675
100,000	500,000	750	1,050
500,000	1,000,000	1,025	1,425
1,000,000	3,000,000	1,275	1,725
3,000,000	6,000,000	1,425	2,000
6,000,000	12,000,000	2,300	3,450
12,000,000	And over	6,775	9,525

State of Illinois
Department of Transportation

SPECIAL PROVISION
FOR
SECTION 90 MEASUREMENT AND PAYMENT

This Special Provision amends the provisions of the Standard Specifications for Construction of Airports, adopted April 1, 2012 and shall be construed to be a part thereof, superseding any conflicting provisions thereof applicable to the work under the contract.

90-07 PARTIAL PAYMENTS.

DELETE: The entire section.

ADD: Partial payments will be made to the Contractor at least once each month as the work progresses. The payments will be based upon estimates, prepared by the Resident Engineer, of the value of the work performed and materials complete and in place in accordance with the contract, plans, and specifications. Such partial payments may also include the delivered actual cost of those materials stockpiled and stored in accordance with the Section 90-08 PAYMENT FOR MATERIALS ON HAND. From the amount of partial payment so determined on Federal-Aid projects, there shall be deducted an amount up to ten percent of the cost of the completed work which shall be retained until all conditions necessary for financial closeout of the project are satisfied. The amount of the estimate approved as due for payment will be vouchered by the Department and presented to the State Comptroller for payment. No amount less than \$1,000.00 will be approved for payment other than the final payment. A final voucher for under \$5.00 shall not be paid except through electronic funds transfer. (15 ILCS 405/9(b-1))

It is understood and agreed that the Contractor shall not be entitled to demand or receive partial payment based on quantities of work in excess of those provided in the proposal or covered by approved change orders, except when such excess quantities have been determined by the Engineer to be a part of the final quantity for the item of work in question.

No partial payment shall bind the Department to the acceptance of any materials or work in place as to quality or quantity. All partial payments are subject to correction at the time of final payment as provided in Section 90-09 ACCEPTANCE AND FINAL PAYMENT.

Progress payments may be reduced by liens filed pursuant to Section 23(c) of the Mechanics Lien Act, 770 ILCS 60/23(c).

If a Contractor or subcontractor has defaulted on a loan issued under the Department's Disadvantaged Business Revolving Loan Program (20 ILCS 2705/2705-610) progress payments may be reduced pursuant to the terms of that loan agreement. In such cases, the amount of the estimate related to the work performed by the Contractor or subcontractor, in default of the loan agreement, will be offset, in whole or in part, and vouchered by the Department to the Working Capital Revolving Fund or designated escrow account. Payment for the work shall be considered as issued and received by the Contractor or subcontractor on the date of the offset voucher. Further, the amount of the offset voucher shall be a credit against the Department's obligation to pay the Contractor, the Contractor's obligation to pay the subcontractor, and the Contractor's or subcontractor's total loan indebtedness to the Department. The offset shall continue until such time as the entire loan indebtedness is satisfied. The Department will notify the Contractor and Fund Control Agent in a timely manner of such offset. The Contractor or subcontractor shall not be entitled to additional payment in consideration of the offset.

In accordance with 49 USC § 47111, the Department will not make payments totaling more than 90 percent of the contract until all conditions necessary for financial closeout of the project are satisfied.

The failure to perform any requirement, obligation, or term of the contract by the Contractor shall be reason for withholding any progress payments until the Department determines that compliance has been achieved.

90-10 TRUST AGREEMENT OPTION.

DELETE: The entire section.

STATE OF ILLINOIS

SPECIAL PROVISIONS

The following Special Provisions supplement the "Standard Specifications for Construction of Airports," adopted April 1, 2012, and the Special Provisions included herein which apply to and govern the airport improvement of: Rehabilitate Airport Entrance Road and Parking Lot at Whiteside County, Contract WH017, and in case of conflict with any part or parts of said Specifications, the said Special Provisions shall take precedence and shall govern.

SPECIAL PROVISION FOR COMPLETION TIME VIA CALENDAR DAYS

It being understood and agreed that the completion within the time limit is an essential part of the contract, the bidder agrees to complete the work within **35 calendar days**, unless additional time is granted by the Engineer in accordance with the provisions of the specifications. In case of failure to complete the work on or before the time named herein, or within such extra time as may have been allowed by extensions, the bidder agrees that the Department of Transportation shall withhold from such sum as may be due him/her under the terms of this contract, the costs, as set forth in Section 80-09 Failure to Complete on Time of the Standard Specifications, which costs shall be considered and treated not as a penalty but as damages due to the State from the bidder by reason of the failure of the bidder to complete the work within the time specified in the contract.

CONSTRUCTION AIR QUALITY – DIESEL VEHICLE EMISSIONS CONTROL (BDE)

Effective: April 1, 2009

Revised: January 2, 2012

Diesel Vehicle Emissions Control. The reduction of construction air emissions shall be accomplished by using cleaner burning diesel fuel. The term "equipment" refers to any and all diesel fuel powered devices rated at 50 hp and above, to be used on the project site in excess of seven calendar days over the course of the construction period on the project site (including any "rental" equipment).

All equipment on the jobsite, with engine ratings of 50 hp and above, shall be required to: use Ultra Low Sulfur Diesel fuel (ULSD) exclusively (15 ppm sulfur content or less).

Diesel powered equipment in non-compliance will not be allowed to be used on the project site, and is also subject to a notice of non-compliance as outlined below.

The Contractor shall certify that only ULSD will be used in all jobsite equipment. The certification shall be presented to the Department prior to the commencement of the work.

If any diesel powered equipment is found to be in non-compliance with any portion of this specification, the Engineer will issue the Contractor a notice of non-compliance and identify an appropriate period of time, as outlined below under environmental deficiency deduction, in which to bring the equipment into compliance or remove it from the project site.

Any costs associated with bringing any diesel powered equipment into compliance with these diesel vehicle emissions controls shall be considered as included in the contract unit prices bid for the various items of work involved and no additional compensation will be allowed. The Contractor's compliance with this notice and any associated regulations shall also not be grounds for a claim.

Environmental Deficiency Deduction. When the Engineer is notified, or determines that an environmental control deficiency exists, he/she will notify the Contractor in writing, and direct the Contractor to correct the deficiency within a specified time period. The specified time-period, which begins upon Contractor notification, will be from 1/2 hour to 24 hours long, based on the urgency of the situation and the nature of the deficiency. The Engineer shall be the sole judge regarding the time period.

The deficiency will be based on lack of repair, maintenance and diesel vehicle emissions control.

If the Contractor fails to correct the deficiency within the specified time frame, a daily monetary deduction will be imposed for each calendar day or fraction thereof the deficiency continues to exist. The calendar day(s) will begin when the time period for correction is exceeded and end with the Engineer's written acceptance of the correction. The daily monetary deduction will be \$1,000.00 for each deficiency identified.

If a Contractor or subcontractor accumulates three environmental deficiency deductions in a contract period, the Contractor will be shutdown until the deficiency is corrected. Such a shutdown will not be grounds for any extension of contract time, waiver of penalties, or be grounds for any claim.

CONSTRUCTION AIR QUALITY – IDLING RESTRICTION (BDE)

Effective: April 1, 2009

Idling Restrictions. The Contractor shall establish truck-staging areas for all diesel powered vehicles that are waiting to load or unload material at the jobsite. Staging areas shall be located where the diesel emissions from the equipment will have a minimum impact on adjacent sensitive receptors. The Department will review the selection of staging areas, whether within or outside the existing highway right-of-way, to avoid locations near sensitive areas or populations to the extent possible. Sensitive receptors include, but are not limited to, hospitals, schools, residences, motels, hotels, daycare facilities,

elderly housing and convalescent facilities. Diesel powered engines shall also be located as far away as possible from fresh air intakes, air conditioners, and windows. The Engineer will approve staging areas before implementation.

Diesel powered vehicle operators may not cause or allow the motor vehicle, when it is not in motion, to idle for more than a total of 10 minutes within any 60 minute period, except under any of the following circumstances:

- 1) The motor vehicle has a gross vehicle weight rating of less than 8000 lb (3630 kg).
- 2) The motor vehicle idles while forced to remain motionless because of on-highway traffic, an official traffic control device or signal, or at the direction of a law enforcement official.
- 3) The motor vehicle idles when operating defrosters, heaters, air conditioners, or other equipment solely to prevent a safety or health emergency.
- 4) A police, fire, ambulance, public safety, other emergency or law enforcement motor vehicle, or any motor vehicle used in an emergency capacity, idles while in an emergency or training mode and not for the convenience of the vehicle operator.
- 5) The primary propulsion engine idles for maintenance, servicing, repairing, or diagnostic purposes if idling is necessary for such activity.
- 6) A motor vehicle idles as part of a government inspection to verify that all equipment is in good working order, provided idling is required as part of the inspection.
- 7) When idling of the motor vehicle is required to operate auxiliary equipment to accomplish the intended use of the vehicle (such as loading, unloading, mixing, or processing cargo; controlling cargo temperature; construction operations, lumbering operations; oil or gas well servicing; or farming operations), provided that this exemption does not apply when the vehicle is idling solely for cabin comfort or to operate non-essential equipment such as air conditioning, heating, microwave ovens, or televisions.
- 8) When the motor vehicle idles due to mechanical difficulties over which the operator has no control.
- 9) The outdoor temperature is less than 32 °F (0 °C) or greater than 80 °F (26 °C).

When the outdoor temperature is greater than or equal to 32 °F (0 °C) or less than or equal to 80 °F (26 °C), a person who operates a motor vehicle operating on diesel fuel shall not cause or allow the motor vehicle to idle for a period greater than 30 minutes in any 60 minute period while waiting to weigh, load, or unload cargo or freight, unless the vehicle is in a line of vehicles that regularly and periodically moves forward.

The above requirements do not prohibit the operation of an auxiliary power unit or generator set as an alternative to idling the main engine of a motor vehicle operating on diesel fuel.

Environmental Deficiency Deduction. When the Engineer is notified, or determines that an environmental control deficiency exists based on non-compliance with the idling restrictions, he/she will notify the Contractor, and direct the Contractor to correct the deficiency.

If the Contractor fails to correct the deficiency a monetary deduction will be imposed. The monetary deduction will be \$1,000.00 for each deficiency identified.

SPECIAL PROVISION FOR DISADVANTAGED BUSINESS ENTERPRISE PARTICIPATION

Effective: September 1, 2000

Revised: March 2, 2019

FEDERAL OBLIGATION. The Department of Transportation, as a recipient of federal financial assistance, is required to take all necessary and reasonable steps to ensure nondiscrimination in the award and administration of contracts. Consequently, the federal regulatory provisions of 49 CFR Part 26 apply to this contract concerning the utilization of disadvantaged business enterprises. For the purposes of this Special Provision, a disadvantaged business enterprise (DBE) means a business certified by the Department in accordance with the requirements of 49 CFR Part 26 and listed in the Illinois Unified Certification Program (IL UCP) DBE Directory.

STATE OBLIGATION. This Special Provision will also be used by the Department to satisfy the requirements of the Business Enterprise for Minorities, Females, and Persons with Disabilities Act, 30 ILCS 575. When this Special Provision is used to satisfy state law requirements on 100 percent state-funded contracts, the federal government has no involvement in such contracts (not a federal-aid contract) and no responsibility to oversee the implementation of this Special Provision by the Department on those contracts. DBE participation on 100 percent state-funded contracts will not be credited toward fulfilling the Department's annual overall DBE goal required by the US Department of Transportation to comply with the federal DBE program requirements.

CONTRACTOR ASSURANCE. The Contractor makes the following assurance and agrees to include the assurance in each subcontract the Contractor signs with a subcontractor.

The Contractor, subrecipient, or subcontractor shall not discriminate on the basis of race, color, national origin, or sex in the performance of this contract. The Contractor shall carry out applicable requirements of 49 CFR Part 26 in the award and administration of contracts funded in whole or in part with federal or state funds. Failure by the Contractor to carry out these requirements is a material breach of this contract, which may result in the termination of this contract or such other remedy as the recipient deems appropriate, which may include, but is not limited to:

- (a) Withholding progress payments;
- (b) Assessing sanctions;
- (c) Liquidated damages; and/or
- (d) Disqualifying the Contractor from future bidding as non-responsible.

OVERALL GOAL SET FOR THE DEPARTMENT. As a requirement of compliance with 49 CFR Part 26, the Department has set an overall goal for DBE participation in its federally assisted contracts. That goal applies to all federal-aid funds the Department will expend in its federally assisted contracts for the subject reporting fiscal year. The Department is required to make a good faith effort to achieve the overall goal. The dollar amount paid to all approved DBE companies performing work called for in this contract is eligible to be credited toward fulfillment of the Department's overall goal.

CONTRACT GOAL TO BE ACHIEVED BY THE CONTRACTOR. This contract includes a specific DBE utilization goal established by the Department. The goal has been included because the Department has determined the work of this contract has subcontracting opportunities that may be suitable for

performance by DBE companies. The determination is based on an assessment of the type of work, the location of the work, and the availability of DBE companies to do a part of the work. The assessment indicates, in the absence of unlawful discrimination and in an arena of fair and open competition, DBE companies can be expected to perform 4.0% of the work. This percentage is set as the DBE participation goal for this contract. Consequently, in addition to the other award criteria established for this contract, the Department will only award this contract to a bidder who makes a good faith effort to meet this goal of DBE participation in the performance of the work. A bidder makes a good faith effort for award consideration if either of the following is done in accordance with the procedures set for in this Special Provision:

- (a) The bidder documents enough DBE participation has been obtained to meet the goal or,
- (b) The bidder documents a good faith effort has been made to meet the goal, even though the effort did not succeed in obtaining enough DBE participation to meet the goal.

DBE LOCATOR REFERENCES. Bidders shall consult the IL UCP DBE Directory as a reference source for DBE-certified companies. In addition, the Department maintains a letting and item specific DBE locator information system whereby DBE companies can register their interest in providing quotes on particular bid items advertised for letting. Information concerning DBE companies willing to quote work for particular contracts may be obtained by contacting the Department's Bureau of Small Business Enterprises at telephone number (217) 785-4611, or by visiting the Department's website at: <http://www.idot.illinois.gov/doing-business/certifications/disadvantaged-business-enterprise-certification/il-ucp-directory/index>.

BIDDING PROCEDURES. Compliance with this Special Provision is a material bidding requirement and failure of the bidder to comply will render the bid not responsive.

The bidder shall submit a DBE Utilization Plan (form SBE 2026), and a DBE Participation Statement (form SBE 2025) for each DBE company proposed for the performance of work to achieve the contract goal, with the bid. If the Utilization Plan indicates the contract goal will not be met, documentation of good faith efforts shall also be submitted. The documentation of good faith efforts must include copies of each DBE and non-DBE subcontractor quote submitted to the bidder when a non-DBE subcontractor is selected over a DBE for work on the contract. The required forms and documentation must be submitted as a single .pdf file using the "Integrated Contractor Exchange (iCX)" application within the Department's "EBids System".

The Department will not accept a Utilization Plan if it does not meet the bidding procedures set forth herein and the bid will be declared not responsive. In the event the bid is declared not responsive, the Department may elect to cause the forfeiture of the penal sum of the bidder's proposal guaranty and may deny authorization to bid the project if re-advertised for bids.

GOOD FAITH EFFORT PROCEDURES. The contract will not be awarded until the Utilization Plan is approved. All information submitted by the bidder must be complete, accurate and adequately document enough DBE participation has been obtained or document the good faith efforts of the bidder, in the event enough DBE participation has not been obtained, before the Department will commit to the performance of the contract by the bidder. The Utilization Plan will be approved by the Department if the Utilization Plan documents sufficient commercially useful DBE work to meet the contract goal or the bidder submits sufficient documentation of a good faith effort to meet the contract goal pursuant to 49 CFR Part 26, Appendix A. This means the bidder must show that all necessary and reasonable steps were taken to achieve the contract goal. Necessary and reasonable steps are those which, by their scope, intensity and appropriateness to the objective, could reasonably be expected to obtain sufficient DBE participation, even if they were not successful. The Department will consider the quality, quantity, and intensity of the kinds of efforts the bidder has made. Mere *pro forma* efforts, in other words efforts done as a matter of form, are not good faith efforts; rather, the bidder is expected to have taken genuine efforts that would be reasonably expected of a bidder actively and aggressively trying to obtain DBE participation sufficient to meet the contract goal.

(a) The following is a list of types of action that the Department will consider as part of the evaluation of the bidder's good faith efforts to obtain participation. These listed factors are not intended to be a mandatory checklist and are not intended to be exhaustive. Other factors or efforts brought to the attention of the Department may be relevant in appropriate cases and will be considered by the Department.

(1) Soliciting through all reasonable and available means (e.g. attendance at pre-bid meetings, advertising and/or written notices) the interest of all certified DBE companies that have the capability to perform the work of the contract. The bidder must solicit this interest within sufficient time to allow the DBE companies to respond to the solicitation. The bidder must determine with certainty if the DBE companies are interested by taking appropriate steps to follow up initial solicitations.

(2) Selecting portions of the work to be performed by DBE companies in order to increase the likelihood that the DBE goals will be achieved. This includes, where appropriate, breaking out contract work items into economically feasible units to facilitate DBE participation, even when the Contractor might otherwise prefer to perform these work items with its own forces.

(3) Providing interested DBE companies with adequate information about the plans, specifications, and requirements of the contract in a timely manner to assist them in responding to a solicitation.

(4) a. Negotiating in good faith with interested DBE companies. It is the bidder's responsibility to make a portion of the work available to DBE subcontractors and suppliers and to select those portions of the work or material needs consistent with the available DBE subcontractors and suppliers, so as to facilitate DBE participation. Evidence of such negotiation includes the names, addresses, and telephone numbers of DBE companies that were considered; a description of the information provided regarding the plans and specifications for the work selected for subcontracting; and evidence as to why additional agreements could not be reached for DBE companies to perform the work.

b. A bidder using good business judgment would consider a number of factors in negotiating with subcontractors, including DBE subcontractors, and would take a firm's price and capabilities as well as contract goals into consideration. However, the fact that there may be some additional costs involved in finding and using DBE companies is not in itself sufficient reason for a bidder's failure to meet the contract DBE goal, as long as such costs are reasonable. Also the ability or desire of a bidder to perform the work of a contract with its own organization does not relieve the bidder of the responsibility to make good faith efforts. Bidders are not, however, required to accept higher quotes from DBE companies if the price difference is excessive or unreasonable. In accordance with the above Bidding Procedures, the documentation of good faith efforts must include copies of each DBE and non-DBE subcontractor quote submitted to the bidder when a non-DBE subcontractor was selected over a DBE for work on the contract.

(5) Not rejecting DBE companies as being unqualified without sound reasons based on a thorough investigation of their capabilities. The bidder's standing within its industry, membership in specific groups, organizations, or associations and political or social affiliations (for example union vs. non-union employee status) are not legitimate causes for the rejection or non-solicitation of bids in the bidder's efforts to meet the project goal.

(6) Making efforts to assist interested DBE companies in obtaining bonding, lines of credit, or insurance as required by the recipient or Contractor.

- (7) Making efforts to assist interested DBE companies in obtaining necessary equipment, supplies, materials, or related assistance or services.
- (8) Effectively using the services of available minority/women community organizations; minority/women contractors' groups; local, state, and federal minority/women business assistance offices; and other organizations as allowed on a case-by-case basis to provide assistance in the recruitment and placement of DBE companies.
- (b) If the Department determines the bidder has made a good faith effort to secure the work commitment of DBE companies to meet the contract goal, the Department will award the contract provided it is otherwise eligible for award. If the Department determines the bidder has failed to meet the requirements of this Special Provision or that a good faith effort has not been made, the Department will notify the responsible company official designated in the Utilization Plan that the bid is not responsive. The notification will also include a statement of reasons for the adverse determination. If the Utilization Plan is not approved because it is deficient as a technical matter, unless waived by the Department, the bidder will be notified and will be allowed no more than a five calendar day period to cure the deficiency.
- (c) The bidder may request administrative reconsideration of an adverse determination by emailing the Department at "DOT.DBE.UP@illinois.gov" within the five calendar days after the receipt of the notification of the determination. The determination shall become final if a request is not made on or before the fifth calendar day. A request may provide additional written documentation or argument concerning the issues raised in the determination statement of reasons, provided the documentation and arguments address efforts made prior to submitting the bid. The request will be reviewed by the Department's Reconsideration Officer. The Reconsideration Officer will extend an opportunity to the bidder to meet in person to consider all issues of documentation and whether the bidder made a good faith effort to meet the goal. After the review by the Reconsideration Officer, the bidder will be sent a written decision within ten working days after receipt of the request for reconsideration, explaining the basis for finding that the bidder did or did not meet the goal or make adequate good faith efforts to do so. A final decision by the Reconsideration Officer that a good faith effort was made shall approve the Utilization Plan submitted by the bidder and shall clear the contract for award. A final decision that a good faith effort was not made shall render the bid not responsive.

CALCULATING DBE PARTICIPATION. The Utilization Plan values represent work anticipated to be performed and paid for upon satisfactory completion. The Department is only able to count toward the achievement of the overall goal and the contract goal the value of payments made for the work actually performed by DBE companies. In addition, a DBE must perform a commercially useful function on the contract to be counted. A commercially useful function is generally performed when the DBE is responsible for the work and is carrying out its responsibilities by actually performing, managing, and supervising the work involved. The Department and Contractor are governed by the provisions of 49 CFR Part 26.55(c) on questions of commercially useful functions as it affects the work. Specific counting guidelines are provided in 49 CFR Part 26.55, the provisions of which govern over the summary contained herein.

- (a) DBE as the Contractor: 100 percent goal credit for that portion of the work performed by the DBE's own forces, including the cost of materials and supplies. Work that a DBE subcontracts to a non-DBE does not count toward the DBE goals.
- (b) DBE as a joint venture Contractor: 100 percent goal credit for that portion of the total dollar value of the contract equal to the distinct, clearly defined portion of the work performed by the DBE's own forces.
- (c) DBE as a subcontractor: 100 percent goal credit for the work of the subcontract performed by the DBE's own forces, including the cost of materials and supplies, excluding the purchase of materials and supplies or the lease of equipment by the DBE subcontractor from the Contractor or its affiliates. Work that a DBE subcontractor in turn subcontracts to a non-DBE does not count toward the DBE goal.
- (d) DBE as a trucker: 100 percent goal credit for trucking participation provided the DBE is responsible for the management and supervision of the entire trucking operation for which it is responsible. At least one truck owned, operated, licensed, and insured by the DBE must be used on the contract. Credit will be given for the following:
- (1) The DBE may lease trucks from another DBE firm, including an owner-operator who is certified as a DBE. The DBE who leases trucks from another DBE receives credit for the total value of the transportation services the lessee DBE provides on the contract.
- (2) The DBE may also lease trucks from a non-DBE firm, including from an owner-operator. The DBE who leases trucks from a non-DBE is entitled to credit only for the fee or commission it receives as a result of the lease arrangement.
- (e) DBE as a material supplier:
- (1) 60 percent goal credit for the cost of the materials or supplies purchased from a DBE regular dealer.
- (2) 100 percent goal credit for the cost of materials or supplies obtained from a DBE manufacturer.
- (3) 100 percent credit for the value of reasonable fees and commissions for the procurement of materials and supplies if not a DBE regular dealer or DBE manufacturer.

CONTRACT COMPLIANCE. Compliance with this Special Provision is an essential part of the contract. The Department is prohibited by federal regulations from crediting the participation of a DBE included in the Utilization Plan toward either the contract goal or the Department's overall goal until the amount to be applied toward the goals has been paid to the DBE. The following administrative procedures and remedies govern the compliance by the Contractor with the contractual obligations established by the Utilization Plan. After approval of the Utilization Plan and award of the contract, the Utilization Plan and individual DBE Participation Statements become part of the contract. If the Contractor did not succeed in obtaining enough DBE participation to achieve the advertised contract goal, and the Utilization Plan was approved and contract awarded based upon a determination of good faith, the total dollar value of DBE work calculated in the approved Utilization Plan as a percentage of the awarded contract value shall become the amended contract goal. All work indicated for performance by an approved DBE shall be performed, managed, and supervised by the DBE executing the DBE Participation Commitment Statement.

- (a) **NO AMENDMENT.** No amendment to the Utilization Plan may be made without prior written approval from the Department's Bureau of Small Business Enterprises. All requests for amendment to the Utilization Plan shall be emailed to the Department at DOT.DBE.UP@illinois.gov.
- (b) **CHANGES TO WORK.** Any deviation from the DBE condition-of-award or contract plans, specifications, or special provisions must be approved, in writing, by the Department as provided elsewhere in the Contract. The Contractor shall notify affected DBEs in writing of any changes in

the scope of work which result in a reduction in the dollar amount condition-of-award to the contract. Where the revision includes work committed to a new DBE subcontractor, not previously involved in the project, then a Request for Approval of Subcontractor, Department form BC 260A or AER 260A, must be signed and submitted. If the commitment of work is in the form of additional tasks assigned to an existing subcontract, a new Request for Approval of Subcontractor will not be required. However, the Contractor must document efforts to assure the existing DBE subcontractor is capable of performing the additional work and has agreed in writing to the change.

(c) SUBCONTRACT. The Contractor must provide copies of DBE subcontracts to the Department upon request. Subcontractors shall ensure that all lower tier subcontracts or agreements with DBEs to supply labor or materials be performed in accordance with this Special Provision.

(d) ALTERNATIVE WORK METHODS. In addition to the above requirements for reductions in the condition of award, additional requirements apply to the two cases of Contractor-initiated work substitution proposals. Where the contract allows alternate work methods which serve to delete or create underruns in condition of award DBE work, and the Contractor selects that alternate method or, where the Contractor proposes a substitute work method or material that serves to diminish or delete work committed to a DBE and replace it with other work, then the Contractor must demonstrate one of the following:

(1) The replacement work will be performed by the same DBE (as long as the DBE is certified in the respective item of work) in a modification of the condition of award; or

(2) The DBE is aware its work will be deleted or will experience underruns and has agreed in writing to the change. If this occurs, the Contractor shall substitute other work of equivalent value to a certified DBE or provide documentation of good faith efforts to do so; or

(3) The DBE is not capable of performing the replacement work or has declined to perform the work at a reasonable competitive price. If this occurs, the Contractor shall substitute other work of equivalent value to a certified DBE or provide documentation of good faith efforts to do so.

(e) TERMINATION AND REPLACEMENT PROCEDURES. The Contractor shall not terminate or replace a DBE listed on the approved Utilization Plan, or perform with other forces work designated for a listed DBE except as provided in this Special Provision. The Contractor shall utilize the specific DBEs listed to perform the work and supply the materials for which each is listed unless the Contractor obtains the Department's written consent as provided in subsection (a) of this part. Unless Department consent is provided for termination of a DBE subcontractor, the Contractor shall not be entitled to any payment for work or material unless it is performed or supplied by the DBE in the Utilization Plan.

As stated above, the Contractor shall not terminate or replace a DBE subcontractor listed in the approved Utilization Plan without prior written consent. This includes, but is not limited to, instances in which the Contractor seeks to perform work originally designated for a DBE subcontractor with its own forces or those of an affiliate, a non-DBE firm, or with another DBE firm. Written consent will be granted only if the Bureau of Small Business Enterprises agrees, for reasons stated in its concurrence document, that the Contractor has good cause to terminate or replace the DBE firm. Before transmitting to the Bureau of Small Business Enterprises any request to terminate and/or substitute a DBE subcontractor, the Contractor shall give notice in writing to the DBE subcontractor, with a copy to the Bureau, of its intent to request to terminate and/or substitute, and the reason for the request. The Contractor shall give the DBE five days to respond to the Contractor's notice. The DBE so notified shall advise the Bureau and the Contractor of the reasons, if any, why it objects to the proposed termination of its subcontract and why the Bureau should not approve the Contractor's action. If required in a particular case as a matter of public necessity, the Bureau may provide a response period shorter than five days.

For purposes of this paragraph, good cause includes the following circumstances:

(1) The listed DBE subcontractor fails or refuses to execute a written contract;

(2) The listed DBE subcontractor fails or refuses to perform the work of its subcontract in a way consistent with normal industry standards. Provided, however, that good cause does not exist if the failure or refusal of the DBE subcontractor to perform its work on the subcontract results from the bad faith or discriminatory action of the Contractor;

(3) The listed DBE subcontractor fails or refuses to meet the Contractor's reasonable, nondiscriminatory bond requirements;

(4) The listed DBE subcontractor becomes bankrupt, insolvent, or exhibits credit unworthiness;

(5) The listed DBE subcontractor is ineligible to work on public works projects because of suspension and debarment proceedings pursuant 2 CFR Parts 180, 215 and 1200 or applicable state law.

(6) The Contractor has determined the listed DBE subcontractor is not a responsible contractor;

(7) The listed DBE subcontractor voluntarily withdraws from the projects and provides written notice to the Contractor of its withdrawal;

(8) The listed DBE is ineligible to receive DBE credit for the type of work required;

(9) A DBE owner dies or becomes disabled with the result that the listed DBE subcontractor is unable to complete its work on the contract;

(10) Other documented good cause that compels the termination of the DBE subcontractor. Provided, that good cause does not exist if the Contractor seeks to terminate a DBE it relied upon to obtain the contract so that the Contractor can self-perform the work for which the DBE contractor was engaged or so that the Contractor can substitute another DBE or non-DBE contractor after contract award.

When a DBE is terminated or fails to complete its work on the Contract for any reason, the Contractor shall make a good faith effort to find another DBE to substitute for the original DBE to perform at least the same amount of work under the contract as the terminated DBE to the extent needed to meet the established Contract goal. The good faith efforts shall be documented by the Contractor. If the Department requests documentation under this provision, the Contractor shall submit the documentation within seven days, which may be extended for an additional seven days if necessary at the request of the Contractor. The Department will provide a written determination to the Contractor stating whether or not good faith efforts have been demonstrated.

(f) FINAL PAYMENT. After the performance of the final item of work or delivery of material by a DBE and final payment therefore to the DBE by the Contractor, but not later than 30 calendar days after payment has been made by the Department to the Contractor for such work or material, the Contractor shall submit a DBE Payment Agreement on Department form SBE 2115 to the Resident Engineer. If full and final payment has not been

made to the DBE, the DBE Payment Agreement shall indicate whether a disagreement as to the payment required exists between the Contractor and the DBE or if the Contractor believes the work has not been satisfactorily completed. If the Contractor does not have the full amount of work indicated in the Utilization Plan performed by the DBE companies indicated in the Utilization Plan and after good faith efforts are reviewed, the Department may deduct from contract payments to the Contractor the amount of the goal not achieved as liquidated and ascertained damages. The Contractor may request an administrative reconsideration of any amount deducted as damages pursuant to subsection (h) of this part.

(g) **ENFORCEMENT.** The Department reserves the right to withhold payment to the Contractor to enforce the provisions of this Special Provision. Final payment shall not be made on the contract until such time as the Contractor submits sufficient documentation demonstrating achievement of the goal in accordance with this Special Provision or after liquidated damages have been determined and collected.

(h) **RECONSIDERATION.** Notwithstanding any other provision of the contract, including but not limited to Article 109.09 of the Standard Specifications, the Contractor may request administrative reconsideration of a decision to deduct the amount of the goal not achieved as liquidated damages. A request to reconsider shall be delivered to the Contract Compliance Section and shall be handled and considered in the same manner as set forth in paragraph (c) of "Good Faith Effort Procedures" of this Special Provision, except a final decision that a good faith effort was not made during contract performance to achieve the goal agreed to in the Utilization Plan shall be the final administrative decision of the Department. The result of the reconsideration process is not administratively appealable to the U.S. Department of Transportation.

SPECIAL PROVISION FOR WEEKLY DBE TRUCKING REPORTS (BDE)

Effective: June 2, 2012
Revised: November 1, 2021

The Contractor shall submit a weekly report of Disadvantaged Business Enterprise (DBE) trucks hired by the Contractor or subcontractors (i.e. not owned by the Contractor or subcontractors) that are used for DBE goal credit.

The report shall be submitted to the Resident Engineer on Division of Aeronautics Form "AER 723" within ten business days following the reporting period. The reporting period shall be Sunday through Saturday for each week reportable trucking activities occur.

Any costs associated with providing weekly DBE trucking reports shall be considered as included in the contract unit prices bid for the various items of work involved and no additional compensation will be allowed.

SPECIAL PROVISION FOR SUBCONTRACTOR MOBILIZATION PAYMENTS

Effective: November 2, 2017
Revised: April 1, 2019

To account for the preparatory work and the operations necessary for the movement of subcontractor personnel, equipment, supplies, and incidentals to the project site and for all other work or operations that must be performed or costs incurred when beginning work approved for subcontracting according to Section 80-01 of the Standard Specifications, the Contractor shall make a mobilization payment to each subcontractor.

This mobilization payment shall be made at least seven days prior to the subcontractor starting work. The amount paid shall be at the following percentage of the amount of the subcontract reported on form AER 260A submitted for the approval of the subcontractor's work.

Value of Subcontract Reported on Form AER 260A	Mobilization Percentage
Less than \$10,000	25%
\$10,000 to less than \$20,000	20%
\$20,000 to less than \$40,000	18%
\$40,000 to less than \$60,000	16%
\$60,000 to less than \$80,000	14%
\$80,000 to less than \$100,000	12%
\$100,000 to less than \$250,000	10%
\$250,000 to less than \$500,000	9%
\$500,000 to \$750,000	8%
Over \$750,000	7%

The mobilization payment to the subcontractor is an advance payment of the reported amount of the subcontract and is not a payment in addition to the amount of the subcontract; therefore, the amount of the advance payment will be deducted from future progress payments.

This provision shall be incorporated directly or by reference into each subcontract approved by the Department.

SPECIAL PROVISION FOR PAYMENTS TO SUBCONTRACTORS

Effective: November 2, 2017

Federal regulations found at 49 CFR §26.29 mandate the Department to establish a contract clause to require Contractors to pay subcontractors for satisfactory performance of their subcontracts and to set the time for such payments.

State law also addresses the timing of payments to be made to subcontractors and material suppliers. Section 7 of the Prompt Payment Act, 30 ILCS 540/7, requires that when a Contractor receives any payment from the Department, the Contractor shall make corresponding, proportional payments to each subcontractor and material supplier performing work or supplying material within 15 calendar days after receipt of the Department payment. Section 7 of the Act further provides that interest in the amount of two percent per month, in addition to the payment due, shall be paid to any subcontractor or material supplier by the Contractor if the payment required by the Act is withheld or delayed without reasonable cause. The Act also provides that the time for payment required and the calculation of any interest due applies to transactions between subcontractors and lower-tier subcontractors and material suppliers throughout the contracting chain.

This Special Provision establishes the required federal contract clause, and adopts the 15 calendar day requirement of the State Prompt Payment Act for purposes of compliance with the federal regulation regarding payments to subcontractors. This contract is subject to the following payment obligations.

When progress payments are made to the Contractor according to Article 90-07 of the Standard Specifications, the Contractor shall make a corresponding payment to each subcontractor and material supplier in proportion to the work satisfactorily completed by each subcontractor and for the material supplied to perform any work of the contract. The proportionate amount of partial payment due to each subcontractor and material supplier throughout the contracting chain shall be determined by the quantities measured or otherwise determined as eligible for payment by the Department and included in the progress payment to the Contractor. Subcontractors and material suppliers shall be paid by the Contractor within 15 calendar days after the receipt of payment from the Department. The Contractor shall not hold retainage from the subcontractors. These obligations shall also apply to any payments made by subcontractors and material suppliers to their subcontractors and material suppliers; and to all payments made to lower tier subcontractors and material suppliers throughout the contracting chain. Any payment or portion of a payment subject to this provision may only be withheld from the subcontractor or material supplier to whom it is due for reasonable cause. If reasonable cause is asserted, written notice shall be provided to the applicable subcontractor and/or material supplier and the Engineer within five days of the Contractor receiving payment. The written notice shall identify the contract number, the subcontract or material purchase agreement, a detailed reason for refusal, the value of payment being withheld, and the specific remedial actions required of the subcontractor and/or material supplier so that payment can be made.

This Special Provision does not create any rights in favor of any subcontractor or material supplier against the State or authorize any cause of action against the State on account of any payment, nonpayment, delayed payment, or interest claimed by application of the State Prompt Payment Act. The Department will not approve any delay or postponement of the 15 day requirement except for reasonable cause shown after notice and hearing pursuant to Section 7(b) of the State Prompt Payment Act. State law creates other and additional remedies available to any subcontractor or material supplier, regardless of tier, who has not been paid for work properly performed or material furnished. These remedies are a lien against public funds set forth in Section 23(c) of the Mechanics Lien Act, 770 ILCS 60/23(c), and a recovery on the Contractor's payment bond according to the Public Construction Bond Act, 30 ILCS 550.

SPECIAL PROVISION FOR SUBCONTRACTOR AND DBE PAYMENT REPORTING (BDE)

Effective: April 2, 2018

Subcontractor and Disadvantaged Business Enterprise Payment Reporting

The Contractor shall report all payments made to the following parties:

- (a) first tier subcontractors;
- (b) lower tier subcontractors affecting disadvantaged business enterprise (DBE) goal credit;
- (c) material suppliers or trucking firms that are part of the Contractor's submitted DBE utilization plan.

The report shall be made through the Department's on-line subcontractor payment reporting system within 21 days of making the payment.

SPECIAL PROVISION FOR NPDES CERTIFICATION

In accordance with the provisions of the Illinois Environmental Protection Act, the Illinois Pollution Control Board Rules and Regulations (35 Ill. Adm. Code, Subtitle C, Chapter I), and the Clean Water Act, and the regulations thereunder, this certification is required for all construction contracts that will result in the disturbance of one or more acres total land area.

The bidder certifies under penalty of law that he/she understands the terms and conditions of the general National Pollutant Discharge Elimination System (NPDES) permit (ILR100000) that authorizes the storm water discharges associated with industrial activity from the construction site identified as part of this certification.

The Airport Owner or its Agent will:

- 1) prepare, sign and submit the Notice of Intent (NOI)
- 2) conduct site inspections and complete and file the inspection reports
- 3) submit Incidence of Non-Compliance (ION) forms
- 4) submit Notice of Termination (NOT) form

Prior to the issuance of the Notice-to-Proceed, for each erosion control measure identified in the Storm Water Pollution Prevention Plan, the contractor or subcontractor responsible for the control measure(s) must sign the above certification (forms to be provided by the Department).

ILLINOIS WORKS APPRENTICESHIP INITIATIVE – STATE FUNDED CONTRACTS (BDE)

Effective: June 2, 2021

Revised: September 2, 2021

Illinois Works Jobs Program Act (30 ILCS 559/20-1 et seq.). For contracts having an awarded contract value of \$500,000 or more, the Contractor shall comply with the Illinois Works Apprenticeship Initiative (30 ILCS 559/20-20 to 20-25) and all applicable administrative rules. The goal of the Illinois Apprenticeship Works Initiative is that apprentices will perform either 10% of the total labor hours actually worked in each prevailing wage classification or 10% of the estimated labor hours in each prevailing wage classification, whichever is less. The Contractor may seek from the Department of Commerce and Economic Opportunity (DCEO) a waiver or reduction of this goal in certain circumstances pursuant to 30 ILCS 559/20-20(b). The Contractor shall ensure compliance during the term of the contract and will be required to report on and certify its compliance. An apprentice use plan, apprentice hours, and a compliance certification shall be submitted to the Engineer on forms provided by the Department and/or DCEO.

REVISIONS TO THE ILLINOIS PREVAILING WAGE RATES

The Prevailing rates of wages are included in this Contract proposal. The rates have been ascertained and certified by the Illinois Department of Labor for the locality in which the work is to be performed and for each craft or type of work or mechanic needed to execute the work of the Contract. As required by Prevailing Wage Act ([820 ILCS](#) 130/0.01, et seq.) and this Proposal, not less than the rates of wages ascertained by the Illinois Department of Labor and as revised during the performance of a Contract shall be paid to all laborers, workers and mechanics performing work under the Contract. Post the scale of wages in a prominent and easily accessible place at the site of work.

If the Illinois Department of Labor revises the prevailing rates of wages to be paid as listed in the specification of rates, the contractor shall post the revised rates of wages and shall pay not less than the revised rates of wages. Current wage rate information shall be obtained by visiting the Illinois Department of Labor web site at <https://www2.illinois.gov/idol/Laws-Rules/CONMED/Pages/Rates.aspx> or by calling 312-793-2814. It is the responsibility of the contractor to review the rates applicable to the work of the contract at regular intervals in order to insure the timely payment of current rates. Provision of this information to the contractor by means of the Illinois Department of Labor web site satisfies the notification of revisions by the Department to the contractor pursuant to the Act, and the contractor agrees that no additional notice is required. The contractor shall notify each of its subcontractors of the revised rates of wages.

SECTION III

Special Provisions

For

REHABILITATE AIRPORT ENTRANCE ROAD AND PARKING LOTS

ILLINOIS PROJECT: SQI-5049

at

WHITESIDE COUNTY AIRPORT – JOSEPH H. BITTORF FIELD
STERLING/ROCK FALLS, ILLINOIS



FINAL SUBMITTAL
JULY 28, 2023



Prepared By:

CRAWFORD, MURPHY & TILLY, INC.
CONSULTING ENGINEERS
3300 69TH Avenue, Suite 2
Moline, Illinois 61265
<http://www.cmtengr.com>



21001628.00

GENERAL

These Special Provisions, together with applicable Standard Specifications, Rules and Regulations, Contract Requirements for Airport Improvement Projects, Payroll Requirements and Minimum Wage Rates which are hereto attached or which by reference are herein incorporated, cover the requirements of the State of Illinois, Department of Transportation, Division of Aeronautics for the construction of the subject project at the Whiteside County Airport –Joseph H. Bittorf Field, Sterling/Rock Falls, Illinois.

GOVERNING SPECIFICATIONS AND RULES AND REGULATIONS

The “**Standard Specifications for Construction of Airports**”, State of Illinois, Department of Transportation, Division of Aeronautics, adopted April 1, 2012 shall govern the project except as otherwise noted in these Special Provisions. In the case of conflict with any part or parts of said specifications, the said Special Provisions shall take precedence and shall govern.

Specifications may be obtained at

<http://www.idot.illinois.gov/home/resources/Manuals/Manuals-and-Guides>

Where referenced within the Special Provisions, the Illinois Department of Transportation Standard Specifications for Road and Bridge Construction adopted January 1, 2022 shall apply.

INDEX TO SPECIAL PROVISIONS

<u>ITEM – DESCRIPTION</u>	<u>PAGE NUMBER</u>
DIVISION I – GENERAL PROVISIONS	1
SECTION 40 – SCOPE OF WORK	1
SECTION 50 – CONTROL OF WORK	4
SECTION 60 – CONTROL OF MATERIALS	6
SECTION 70 – LEGAL REGULATIONS AND RESPONSIBILITY TO PUBLIC	7
SECTION 80 – PROSECUTION AND PROGRESS	9
SECTION 90 – MEASUREMENT AND PAYMENT	11
DIVISION II – PAVING CONSTRUCTION DETAILS	12
ITEM 150520 – MOBILIZATION	12
ITEM 156000 – EROSION CONTROL	13
ITEM 201661 – CLEAN & SEAL BITUMINOUS CRACKS	14
ITEM 401000 – BITUMINOUS SURFACE COURSE - SUPERPAVE	15
ITEM 401650 – BITUMINOUS PAVEMENT MILLING	17
ITEM 501000 – PORTLAND CEMENT CONCRETE PAVEMENT	18
ITEM 603000 – BITUMINOUS TACK COAT	21
ITEM 620000 – PAVEMENT MARKING	22
DIVISION III – FENCING (WIRE FENCES)	23
ITEM 162 – CHAIN-LINK FENCES	23
DIVISION VIII – MISCELLANEOUS	25
ITEM 910975 – RELOCATE ROADWAY SIGN	25

IDOT DIVISION OF AERONAUTICS POLICY MEMORANDA

A

- 87-4 DETERMINATION OF BULK SPECIFIC GRAVITY (d) OF COMPACTED BITUMINOUS MIXES
- 96-1A ITEM 610, STRUCTURAL PORTLAND CEMENT CONCRETE: JOB MIX FORMULA APPROVAL & PRODUCTION TESTING
- 96-3 REQUIREMENTS FOR QUALITY ASSURANCE ON PROJECTS WITH BITUMINOUS CONCRETE PAVING
- 97-2 PAVEMENT MARKING PAINT ACCEPTANCE
- 2003-1 REQUIREMENTS FOR LABORATORY, TESTING, QUALITY CONTROL, AND PAVING OF SUPERPAVE BITUMINOUS CONCRETE MIXTURES FOR AIRPORTS

IDOT STANDARD DRAWINGS

B

- 720001-01 SIGN PANEL MOUNTING DETAILS
- 720006-04 SIGN PANEL ERECTION DETAILS
- 720011-01 METAL POSTS FOR SIGNS, MARKERS & DELINEATORS
- 729001-01 APPLICATIONS OF TYPES A & B METAL POSTS (FOR SIGN & MARKERS)

DIVISION I – GENERAL PROVISIONS

SECTION 40 – SCOPE OF WORK

40-05 MAINTENANCE OF TRAFFIC

ADD:

The Contractor shall be responsible for cleaning and maintaining all haul roads and use a pick-up type sweeper on all pavements and adjacent roadways utilized in hauling operations when material is tracked onto said pavement. **The Contractor shall have a sweeper on site and maintain all pavements clear of dirt and debris at all times or as requested by the Resident Engineer.** If the Contractor fails to comply with the Standard Specifications, Contract Plans or these Special Provisions concerning traffic control, the Resident Engineer shall execute such work as may be deemed necessary to correct deficiencies and the cost thereof shall be deducted from compensation due or which may become due the Contractor under the contract. The Contractor shall be responsible for supplying, maintaining and moving all barricades required for construction. The cost thereof shall not be paid for separately, but shall be considered incidental to the contract unit prices.

The Airport Manager, following consultation with the Resident Engineer, will give proper notice to the nearest Flight Service Station and the Airways Facilities Chief of the Federal Aviation Administration prior to the beginning of construction. The Contractor shall furnish a flagger in radio control with the Air Traffic at any time the active runways, taxiways or airfield pavement are crossed or used for a haul road. The Contractor shall supply his own radios. The cost thereof shall not be paid for separately, but shall be considered incidental to the contract unit prices.

ADD:

40-09 AIRPORT OPERATIONS DURING CONSTRUCTION

a. Construction Activity and Aircraft Movements

For construction activity to be performed in areas other than active operational areas, the storage and parking of equipment and materials, when not in use or about to be installed, shall not encroach upon active operational areas. In protecting operational areas, the minimum clearances maintained for runways shall be in conformance with Part 77 of the Federal Aviation Regulations.

All construction operations shall conform to the plans and in accordance with AC 150/5370-2 (Latest Edition) Operational Safety on Airports during Construction.

b. Limitations on Construction

- (1) Open flame welding or torch cutting operations shall be prohibited, unless adequate fire and safety precautions are provided.
- (2) Open trenches, excavations and stockpiled material near any pavements shall be prominently marked with red flags and lighted by light units during hours of restricted visibility and/or darkness.
- (3) Stockpiled material shall be constrained in a manner to prevent movement resulting from aircraft blast or wind conditions.

- (4) The use of explosives shall be prohibited.
- (5) Burning shall not be allowed.
- c. Debris

Waste and loose material capable of causing damage to aircraft landing gears, propellers, or being ingested in jet engines shall not be placed on active aircraft movement areas. Material tracked on these areas shall be removed continuously during the work. The Contractor shall provide garbage cans in employee parking areas and storage areas for debris.

40-10 BARRICADES, WARNING SIGNS AND HAZARD MARKINGS

The Contractor shall furnish, erect, and maintain all barricades, warning signs, and markings for hazards necessary to protect the public and the work. When used during periods of darkness, such barricades, warning signs and hazard markings shall be suitably illuminated. Unless otherwise specified, barricades, warning signs, and markings for hazards that are in the air operations area shall be a maximum of 18 inches high. Unless otherwise specified, barricades shall be spaced not more than 10 feet apart.

For vehicular and pedestrian traffic, the Contractor shall furnish, erect, and maintain barricades, warning signs, lights and other traffic control devices in reasonable conformity with the Manual of Uniform Traffic Control Devices for Streets and Highways (published by the United States Government Printing Office).

Any cost for signage or traffic control shall be borne by the Contractor.

Barricades, as approved by the FAA, shall be provided per the details in the plan sheets. The barricades shall be lighted with steady burn omni-directional red lights supplemented with a 20" x 20" orange flag.

Barricades shall be placed as shown in the plans or as directed by the Resident Engineer or Airport.

The Contractor shall be responsible for supplying, maintaining and any moving of all barricades. Lights shall be maintained in proper working order. No separate payment will be made for supplying, maintaining and moving barricades but shall be considered incidental to the contract.

When the work requires closing an air operations area of the airport or portion of such area, the Contractor shall furnish, erect, and maintain temporary markings and associated lighting conforming to the requirements of FAA Advisory Circular 150/5340-1 (latest revision), *Standards for Airport Markings*.

The Contractor shall furnish, erect, and maintain markings and associated lighting of open trenches, excavations, temporary stockpiles, and his/her parked construction equipment that may be hazardous to the operation of emergency fire-rescue or maintenance vehicles on the airport in reasonable conformance to FAA Advisory Circular 150/5370-2 (latest revision), *Operational Safety on Airports During Construction*.

The Contractor shall identify each motorized vehicle or piece of construction equipment in reasonable conformance to FAA Advisory Circular 150/5370-2 (latest revision).

Mark and identify vehicles in accordance with AC 150/5210-5 (latest revision) *Painting, Marking and Lighting of Vehicles Used on an Airport*. When any vehicle is required to travel over any portion of the aircraft movement area (within the existing perimeter fence) and runway approach area, the vehicle shall be properly identified to operate in the area or provided with a flag on a staff attached to the vehicle so that the flag will be readily visible. The flag should be not less than 3-foot square consisting of a checkered pattern of international orange and white squares of not less than one foot on each side and

displayed in full view above the vehicle. A flag or escort vehicle is not required for vehicles which have been painted, marked and lighted for routine use on aircraft movement areas. Any vehicle operating on the movement area during the hours of darkness should be equipped with an amber flashing dome-type light, in accordance with local and/or state codes.

The Contractor shall furnish and erect all barricades, warning signs, and markings for hazards prior to commencing work which requires such erection and shall maintain the barricades, warning signs, and markings for hazards until their dismantling is directed by the Resident Engineer.

Open-flame type lights shall not be permitted within the air operations areas of the airport.

SECTION 50 – CONTROL OF WORK

50-06 CONSTRUCTION LAYOUT STAKES

RESPONSIBILITY OF THE RESIDENT ENGINEER

DELETE:

Paragraphs A and B and replace with the following:

- A. The Resident Engineer will locate and reference two (2) control points within the limits of the project.
- B. A benchmark has been established along the project outside of construction lines.

ADD:

M. It is not the responsibility of the Resident Engineer to check the correctness of the Contractor's stakes or forms, except as provided herein; however, any errors that are apparent shall be immediately called to the Contractor's attention, and he shall be required to make the necessary correction before the stakes are used for construction purposes.

RESPONSIBILITY OF THE CONTRACTOR

ADD:

- H. The Contractor shall immediately notify the Resident Engineer of conflicts or discrepancies with the established control points.
- I. Construction layout shall not be paid for separately, but shall be considered incidental to the pay item for which the layout is required.

50-10 INSPECTION OF WORK

ADD:

The Contractor shall provide portable flood lighting for nighttime construction. Sufficient units shall be provided so that work areas are illuminated to a level of five horizontal foot candles. The lighting levels shall be calculated and measured in accordance with the current standards of the Illumination Engineering Society. Lights shall be positioned so as not to interfere with Airport operations.

50-12 LOAD RESTRICTIONS

ADD:

Contractor's use of the existing airfield and perimeter pavements by equipment and loaded trucks shall be minimized. **Any damage to existing airfield and perimeter pavements shall be repaired by the Contractor at his own expense to the satisfaction of the Owner. Contractor shall obtain written permission from the Airport Owner to use any airfield pavements.**

The Contractor shall not be allowed to use FAA access roads at any time.

50-14 FINAL ACCEPTANCE

DELETE: The first sentence of the first paragraph.

ADD: As the first sentence of the first paragraph.

Upon due notice to the Resident Engineer from the Contractor of presumptive completion of the entire project, the charging of Contract Time shall be suspended, and the Engineer will make an inspection.

ADD: After the first sentence of the second paragraph:

The charging of Contract Time shall resume on the day following the inspection and shall continue until the remaining work, including the applicable requirements of Section 40-08, Final Clean-up, is completed to the Engineer's satisfaction.

50-16 PLANS AND WORK DRAWINGS

DELETE:

References to "approval" in second paragraph and replace with "review".

REVISE the fifth paragraph to read:

Shop drawings submitted by the Contractor for materials and/or equipment to be provided as a part of the contract shall be reviewed by the Project Engineer for substantial conformance of said materials and/or equipment, to contract requirements. Shop drawings shall be fully descriptive, complete and of sufficient detail for ready determination of compliance.

REVISE the last paragraph to read:

The following information shall be clearly marked on each shop, working, and layout drawing, catalog cut, pamphlet specifications sheet, etc., submitted.

PROJECT LOCATION:	Whiteside County Airport
PROJECT TITLE:	Rehabilitate Airport Entrance Road and Parking Lots
PROJECT NUMBERS:	IL Project: SQI-5049
CONTRACT ITEM:	(i.e. AR 156520 Inlet Protection)
SUBMITTED BY:	(Contractor/Subcontractor Name)
DATE:	(Date Submitted)

ADD: To the end of the 18th paragraph:

d. "Rejected": Submittal shall not be used at the project site.

SECTION 60 – CONTROL OF MATERIALS

60-01 SOURCE OF SUPPLY AND QUALITY REQUIREMENTS

ADD: After the last paragraph

The Contractor shall certify all materials contained in the contract. Certification documentation shall be submitted to the Engineer. It shall be the sole responsibility of the Contractor to ensure the delivery of adequate and accurate documentation prior to the delivery of the materials.

If, upon delivery and incorporation of any materials, the Contractor has failed to provide the necessary submittals as required by Sections 50-18, 60-01, 60-03 and 60-11 of the Standard Specifications and Special Provisions, the pay item shall not be included on the Construction Progress Payment report until such submittals have been furnished.

60-03 CERTIFICATION OF COMPLIANCE/ANALYSIS (COC/COA)

ADD:

Additional requirements are specified in Section 60-11 Certification of Materials.

60-11 CERTIFICATION OF MATERIALS

ADD:

The Contractor shall certify all materials incorporated into the contract. Certification documentation shall be submitted to the Resident Engineer. It shall be the **sole** responsibility of the Contractor to ensure the submittal of adequate and accurate documentation in order to satisfy the contract material certification requirements **prior** to the delivery of the materials. Materials without certification or those with certification that demonstrates the materials do not meet the requirements of the plans and specifications shall be considered nonconforming and subject to the provisions of Section 50-02.

As a guide to the certification process and requirements, the Contractor shall use the Illinois Department of Transportation/Division of Aeronautics MANUAL FOR DOCUMENTATION OF AIRPORT MATERIALS dated April 1, 2010 or latest edition including any addendums. Copies of this manual are available by contacting Mr. Mike Wilhelm-Division of Aeronautics at (217) 785-4282 or from their website at <http://www.idot.illinois.gov/home/resources/Manuals/Manuals-and-Guides>.

The cost of providing the required material documentation and certifications shall not be paid for separately, but shall be considered incidental to the associated item.

SECTION 70 – LEGAL REGULATIONS AND RESPONSIBILITY TO PUBLIC

70-17 CONTRACTOR’S RESPONSIBILITY FOR UTILITY SERVICE AND FACILITIES OF OTHERS

ADD:

Special care shall be taken on all operations, and particularly near pavement edges, to avoid damage to edge lights and all underground electrical cable on the airport. The approximate location of existing underground cable is shown on drawings. Any airfield lights or cable that are broken and require replacement because of the Contractor's operations will be replaced by the contractor at his own expense.

Any airfield cable repairs or replacement to any part of the electrical system made necessary by the Contractor's operations will be made by him in the manner specified in Sections 108 and 125 at no cost to the airport. Cost of replacement to be borne by the Contractor shall include any expense incurred in locating as well as repairing or replacing damaged parts of the system by the owning agency.

It shall be the Contractor’s responsibility to locate and protect all airport-owned utilities within the construction limits. This includes all electrical cables, storm sewer, drain tile, sanitary sewer and water main.

Special attention is necessary when working near FAA power and control cables. Any FAA utility that is damaged or cut during construction shall be repaired immediately. FAA requires that any damaged cable be replaced in its entirety, from power/control source to the equipment/service. Splices of any kind will not be permitted. Exposures of any FAA cables must be done by hand digging or hydro-excavation. No additional compensation will be made for locating, replacement or repair of FAA facilities or cables but, shall be incidental to the contract.

When FAA cables are required to be located, or the contractor is planning on working on or around FAA cables, conduits or equipment, a 10 working day advanced notice shall be given to the FAA before any such markings are required. Once FAA marks the cables, the contractor will be required to survey the FAA utilities so they can be replaced during construction without remarking by the FAA. This shall be incidental to the contract. The FAA personnel are only available from 9 am to 3 pm, Monday through Friday with advanced notice.

Should any utilities or cables require location, the following people shall be contacted:

WHITESIDE COUNTY AIRPORT

<u>Utility Service or Facility</u>	<u>Contact (Person)</u>	<u>Contact (Phone)</u>
Ameritech – Telephone Cables	J.U.L.I.E. (Joint Utility Locating Information for Excavators)	1-800-892-0123
ComEd - Electric Cables	J.U.L.I.E. (Joint Utility Locating Information for Excavators)	1-800-892-0123
Northern Illinois Gas - Gas Lines	J.U.L.I.E. (Joint Utility Locating Information for Excavators)	1-800-892-0123
FAA – Airways Facilities	Airway Facilities Manager 5701 Falcon Road Rockford, Illinois 61109	1-815-484-5300

70-26 CONTRACTOR'S RESPONSIBILITY FOR SAFETY DURING CONSTRUCTION

ADD the following after Item D.:

E. Provide a safety officer/construction inspector trained in airport safety to monitor construction activities.

F. Restrict movement of construction vehicles to construction areas with flagging and barricading, erecting temporary fencing, or providing escorts, as appropriate or as shown in plans.

G. Ensure that no construction employees, employees of subcontractors or suppliers, or other persons enter any part of the aircraft operations area from construction site unless authorized.

SECTION 80 – PROSECUTION AND PROGRESS

80-03 NOTICE TO PROCEED

ADD:

The Notice to Proceed will not be given until all materials are certified by the Contractor to be available and on hand and meeting the Buy American requirements per the Contract Documents.

80-05 LIMITATION OF OPERATIONS

ADD:

The Contractor shall not have access to any part of the active airfield (runways or taxiways) for any equipment or personnel without approval of the Airport Manager. All operations shall conform to the approved construction activity plan and general notes.

80-07 TEMPORARY SUSPENSION OF THE WORK

REVISE the second paragraph to read:

In the event that the Contractor is ordered by the Engineer to suspend work for some unforeseen cause not otherwise provided for in the contract and over which the Contractor has no control, the Contractor may be reimbursed for actual money expended on the work during the period of shutdown. No allowance will be made for anticipated profits. The period of shutdown shall be computed from the effective date of the Engineer's order to suspend work to the effective date of the Engineer's order to resume the work. Claims for such compensation shall be filed with the Resident Engineer within the time period stated in the Engineer's order to resume work. The Contractor shall submit with his/her claim information substantiating the amount shown on the claim. The Resident Engineer will forward the Contractor's claim to the Division for their consideration in accordance with local laws or ordinances. No provision of this article shall be construed as entitling the Contractor to compensation for delays due to inclement weather, for suspension made at the request of the Engineer, or for any other delay provided for in the contract, plans, or specifications.

80-13 CONTRACTOR'S ACCESS TO AIRFIELD

ADD:

The Contractor shall not have access to any part of the active airfield pavements (runways, aprons, or taxiways, and associated safety areas) for any equipment or personnel without the approval of the Airport Manager. All access to active runway and taxiway pavements shall be coordinated with the Airport Manager. *Access to the referenced pavements without the Airport Manager's approval may result in a determination of an airfield incursion with associated fines.*

Unattended construction access and unauthorized access to the airfield shall be fined in accordance with the fines noted in the plans in the construction phasing notes. Gate guards shall have mobile telephone communications at all times, and shall be required to provide a daily visitor log to the airport at the weekly coordination meetings.

ADD:

80-14 SECURITY DURING CONSTRUCTION

As a minimum, the Contractor shall be responsible for security during construction as follows:

1. Visibly delineate his construction zone by placing a line of barricades or flagging around the entire work zone.
2. Keep construction personnel inside the work area delineated by barricades.
3. Ensure that construction personnel are familiar with security procedures and regulations on the Airport.
4. Restrict movement of construction vehicles to construction areas as flagging and barricading, erecting temporary fencing, or providing escorts, as appropriate or as shown in plans.
5. The Contractor shall be required to maintain security on the Airport as specified or as directed by the Airport.
6. The Contractor shall provide a complete list of personnel that will be employed while on site and update the list as needed. The contractor shall limit access to the AOA. The Contractor shall be responsible for monitoring the access gate during work hours. If the Contractor chooses to leave the gate open, then he shall monitor the gate to prevent unauthorized entries.
7. The contractor shall provide his own padlock to secure the gate used for access.

SECTION 90 – MEASUREMENT AND PAYMENT

90-05 PAYMENT FOR EXTRA AND FORCE ACCOUNT WORK

ADD the following to subsection B.7. Statements:

All statements of the cost of force account work shall be furnished to the Engineer not later than 60 days after completion of the force account work. If the statement is not received within the specified time frame, all demands for payment for the extra work are waived and the Division, Airport Owner and Local Sponsor are released from any and all such demands. It is the responsibility of the Contractor to ensure that all statements are received within the specified time regardless of the manner or method of delivery.

DIVISION II – PAVING CONSTRUCTION DETAILS

ITEM 150520 – MOBILIZATION

BASIS OF PAYMENT

105-3.1

ADD:

Payment will be made under:

ITEM AR150520 MOBILIZATION – PER LUMP SUM.

ITEM 156000 – EROSION CONTROL

DESCRIPTION

156-1.1

ADD:

All entrances to the construction site shall have a stabilized entrance constructed in accordance with Standard IL-630 of the Natural Resources Conservation Service and the current Illinois Urban Manual.

CONSTRUCTION METHODS

156-3.2b TEMPORARY EROSION CONTROL

Inlet filter sediment traps shall be placed in all proposed and existing inlets and catch basins as shown on the plans and hay bales placed around as shown, or as directed by the Resident Engineer.

METHOD OF MEASUREMENT

156-4.2

DELETE: This section.

156-4.3

DELETE: This section.

156-4.5

ADD:

The number of Inlet Protection paid for shall be the number shown in the plans or ordered by the Resident Engineer used to control erosion and satisfactorily completed.

BASIS OF PAYMENT

156-5.1

REVISE: This section to read:

Payment will be made at the contract unit price per each for Inlet Protection. This price shall be full compensation for furnishing all materials for all preparation and installation of these materials, including excavation, placement, tie-down stakes, staples, maintenance and removal and for all labor, equipment, tools, and incidentals necessary to complete this item.

Stabilized construction entrances shall not be measured for payment. It shall be considered incidental to the contract.

Payment will be made under:

ITEM AR156520 INLET PROTECTION – PER EACH.

ITEM 201661 – CLEAN & SEAL BITUMINOUS CRACKS

DESCRIPTION

201-1.1

ADD after the first sentence:

The cracks shall be as designated by the Resident Engineer or as detailed in the Plans.

BASIS OF PAYMENT

201-6.1

ADD:

Payment will be made under:

ITEM AR201661 CLEAN & SEAL BITUMINOUS CRACKS – PER LINEAR FOOT.

ITEM 401000 – BITUMINOUS SURFACE COURSE - SUPERPAVE

(Central Plant Hot Mix)

DESCRIPTION

401-1.1

ADD: The following after the third paragraph of this section:

This project shall utilize Method I for the production, placement and acceptance of the bituminous surface course.

At the Contractor's option, an IDOT Division of Highways surface mix may be submitted for approval by the Engineer. The surface mix shall be in accordance with Section 406 Hot-Mix Asphalt Binder and Surface Course of the Illinois Department of Transportation "Standard Specifications for Road and Bridge Construction." The mix shall be a production mix from the current construction season meeting Mixture Composition:

HOT-MIX ASPHALT SURFACE COURSE, MIX "D", N50, MIX TYPE IL-9.5 mm.

CONSTRUCTION METHODS

401-3.2 JOB MIX FORMULA

ADD: The following after the third paragraph of this section:

Table 1 Superpave Design Criteria for Automobile, Entrance Roads and Parking Lots shall apply.

401-4.12 JOINTS

ADD: The following as the sixth paragraph

If at any time during the surface course paving operation, it becomes necessary to end a paving lane at a location other than the new finished pavement edge because of ending a day's paving, machinery breakdown, etc., the lane end will be sawed back a sufficient distance to provide a smooth, neat appearing joint from which to resume paving. The sawed face will be painted with a tack coat and this work shall be considered incidental to Item 401, Bituminous Surface Course, and no additional compensation will be allowed.

401-4.14 SHAPING EDGES

ADD: The following as the second paragraph for this section:

All pavement edges, including the pavement ends, must be left in proper alignment, as shown on the plans. This may be accomplished by a trimming method, or, at the Contractor's option, by sawing after the paving has been completed. No additional compensation will be made if the sawing method is used.

BASIS OF PAYMENT

401-6.1

ADD:

Payment will be made under:

ITEM AR401611 BIT. SURFACE COURSE – METHOD I – PER TON.

ITEM 401650 – BITUMINOUS PAVEMENT MILLING

CONSTRUCTION METHODS

401-3.1

ADD:

The existing pavement areas to be milled shall be done in such a manner as to prevent damage to the adjacent structures and pavement. All edges adjacent to existing pavements shall be saw-cut full depth of the removal depth prior to removal as directed by the Engineer.

The Contractor shall use caution and exercise care to avoid damage to the existing subgrade by the bituminous milling operations. Excessive construction traffic on the open subgrade areas shall be avoided in the removal areas and any damage or undercutting necessary to repair failed subgrade areas shall be repaired by the Contractor and the cost of the repairs shall be considered incidental to the Bituminous Pavement Milling item.

BASIS OF PAYMENT

401-5.1

ADD:

Payment will be made under:

ITEM AR401650 BITUMINOUS PAVEMENT MILLING – PER SQUARE YARD.

ITEM 501000 – PORTLAND CEMENT CONCRETE PAVEMENT

DESCRIPTION

501-1.1

ADD:

This item shall include providing a 4" PCC sidewalk on a 4" crushed aggregate base course. The crushed aggregate base course shall not be measured separately for payment but shall be included in the unit cost of the new sidewalk.

This item of work shall consist of removing existing PCC sidewalk as shown on the plans or as directed by the Engineer.

MATERIALS

501-2.1 through 2.11

DELETE: These sections. PCC concrete shall meet the material requirements of Section 610. Liquid membrane forming compounds for curing concrete in accordance with ASTM C 309 shall be used.

CONSTRUCTION METHODS

501-3.1 through 3.19

DELETE: These sections. PCC concrete shall meet the construction method requirements of Section 610.

501-3.4 CONDITIONING OF UNDERLYING COURSE, SIDE-FORM CONSTRUCTION

ADD:

All areas shall be constructed true to grade and acceptable to the Engineer prior to paving.

During placement of the concrete pavement, the subbase shall be maintained in a moist condition without accumulation of pools of water.

In the event that the underlying course has become over-saturated or unstable, paving operations shall stop until corrected unless otherwise approved by the Engineer.

501-3.6(A) PROPORTIONS

REVISE: This Section to the following:

An Illinois Department of Transportation "Standard Specifications for Road and Bridge Construction" Section 420 Portland Cement Concrete Class PV concrete generated by the IDOT Division of Highways with recent substantiating test and strength data shall be submitted by the Contractor for approval by the Engineer in accordance with Aeronautics Policy Memorandum 96-1A. The Class PV concrete shall be designed for 14-day compressive strength of 3500 psi in accordance with ASTM C 39.

The air content by the volume shall be between 5% and 8% by volume, based on measurements made on concrete immediately discharged from the mixer in accordance with ASTM C 138 or C231.

The concrete shall have a minimum slump of two (2) inch and maximum slump of four (4) inches when tested in accordance with ASTM C143.

Test batch is not required.

501-3.7 FIELD TEST SPECIMENS

REVISE: This Section to the following:

The Resident Engineer shall obtain field samples for acceptance testing in accordance with Aeronautics Policy Memorandum 96-1A.

501-3.14 SURFACE TEXTURE

ADD:

The surface of the pavement shall be finished with a burlap drag or other approved method acceptable to the Engineer.

501-3.17(A) CURING

Impervious Membrane Method shall be utilized for this project.

501-3.20 PROTECTION OF PAVEMENT

REVISE: This Section to read:

In order that the concrete may be properly protected against the effects of rain before the concrete is sufficiently hardened, the Contractor will be required to have available at all times materials for the protection of the edges and surface of the unhardened concrete. Such protective materials shall consist of standard metal forms or wood plank having a nominal thickness of the pavement at its edge for the protection of the pavement edges and covering material such as curing paper or polyethylene sheeting material for the protection of the surface of the pavement. The metal forms, wood planks and curing paper shall be kept on trucks or towable vehicles, within reasonable hauling distance, at a site shown on the plans, or as designated by the Engineer. Or, as an alternate, rolled polyethylene sheeting of sufficient length and width may be used without the temporary side forms and if properly anchored, to cover the plastic concrete slab and exposed edge. The sheeting may be mounted on either the paver or a separate moveable bridge from which it can be unrolled without dragging over the plastic concrete surface. When rain appears imminent, all paving operations shall stop, and all available personnel shall begin covering the surface of the unhardened concrete with protective covering. All pavement damaged shall be removed and replaced at no additional cost to the contract.

501-3.22 SURFACE TOLERANCES

DELETE: This Section.

501-3.23 QUALITY CONTROL PLAN

DELETE: This Section.

501-3.24 REMOVAL OF DEFECTIVE WORK

ADD:

At locations determined by the Engineer, the Contractor shall be required to remove any pavement or sidewalk which is classified as defective. This includes any area where non-controlled (random) cracking occurs, unacceptable surface texturing or any other defect determined unacceptable by the Engineer. The pavement shall be removed to the nearest joint and replaced at the expense of the Contractor. Prior to replacement, dowels and tie bars will be provided as directed by the Engineer.

METHOD OF MEASUREMENT

501-4.1

DELETE: This Section.

ADD:

PCC SIDEWALK, 4" will be measured per square foot as noted on the plans, completed in place and accepted by the Engineer. No separate measurement will be made for the 4" aggregate base course below the sidewalk. The costs associated for the 4" aggregate base course will be included in the unit price for sidewalk.

PCC SIDEWALK REMOVAL shall be the number of square feet of PCC sidewalk removal as measured in the field, completed and accepted.

BASIS OF PAYMENT

501-5.1 GENERAL

DELETE: This Section.

ADD:

The accepted quantities of PCC Sidewalk 4" shall be paid for at the contract unit price per square foot which price and payment shall be full compensation for furnishing all tools, equipment, labor, concrete, crushed aggregate base course, curing, other materials and incidentals necessary to complete the item.

The accepted quantities of PCC Sidewalk Removal will be paid for at the contract unit price per square foot which price and payment shall be full compensation for furnishing all materials, equipment, labor, hauling, disposal and all other incidental items necessary to complete the work to the satisfaction of the Engineer.

Payment will be made under:

ITEM AR501604 4" PCC SIDEWALK – PER SQUARE FOOT.

ITEM AR501690 PCC SIDEWALK REMOVAL – PER SQUARE FOOT.

ITEM 603000 – BITUMINOUS TACK COAT

CONSTRUCTION METHODS

603-3.3 APPLICATION OF BITUMINOUS MATERIAL

ADD: The following to the second paragraph:

Areas worn from hauling operations shall be re-tacked at no additional cost to the Contract.

BASIS OF PAYMENT

603-5.1

ADD:

If, upon delivery and incorporation of any materials the Contractor has failed to provide the necessary submittals as required by Sections 50-18, 60-01, 60-03 and 60-10 of the Standard and Special Provisions, the pay item shall not be included on the Construction Progress Payment (CPP) until such submittals have been furnished.

Payment will be made under:

ITEM AR603510 BITUMINOUS TACK COAT – PER GALLON.

ITEM 620000 – PAVEMENT MARKING

MATERIALS

620-2.2 PAINT

The paint shall contain no lead, chromium, cadmium or barium.

DELETE: Section (B) Epoxy in its entirety.

METHOD OF MEASUREMENT

620-4.1

ADD:

No distinction will be made between color of paint for payment purposes.

The quantity of permanent markings to be paid for shall be the number of square feet of painting with the specified material **measured only once to apply two coats** (waterborne only) in conformance with the specifications and accepted by the Engineer. No distinction shall be made between paint colors for payment purposes.

BASIS OF PAYMENT

620-5.1

ADD:

If, upon delivery and incorporation of any materials the Contractor has failed to provide the necessary submittals as required by Sections 50-18, 60-01, 60-03 and 60-10 of the Standard and Special Provisions, the pay item shall not be included on the Construction Progress Payment (CPP) until such submittals have been furnished.

Payment will be made under:

ITEM AR620520 PAVEMENT MARKING-WATERBORNE – PER SQUARE FOOT.

DIVISION III – FENCING (WIRE FENCES)

ITEM 162 – CHAIN-LINK FENCES

(Class E)

DESCRIPTION

162-1.1

ADD:

This item of work shall also consist of furnishing and installing new traffic detector loops and removals at the locations shown on the construction plans and in accordance with this specification.

MATERIALS

ADD: The following sections:

162-2.11 DETECTOR LOOP

Detector loop size, location, sawing method, sealant type and number of loops shall be as shown on the plans and as recommended by the manufacturer. The detector shall have adjustable sensitivity and be housed in the operator housing. A detector loop shall be required on each side of the gate.

162-2.12 NON-SHRINK GROUT

The chemical adhesive resin system shall consist of a 2-part, fast setting resin and filler/hardener, and must be on the Illinois Department of Transportation's most recent Approved Non-Shrink Grout List. The latest list is available through the internet at the IDOT website. The adhesive shall be mixed in accordance with the manufacturer's instructions. After sawing, any dust or loose materials shall be blown out with compressed air and shall also be dry.

CONSTRUCTION METHODS

162-3.11

ADD:

The Contractor shall remove, without regard to height, the existing fence, rails, posts, foundations, miscellaneous hardware and gates as shown on the plans. The removed fence materials shall be disposed of off Airport property unless the Airport wishes to retain portions of the removed fence materials in which the Contractor shall haul salvageable fence pieces to the Airport maintenance yard. The resultant void from the removal of fence foundations or posts in turf areas shall be backfilled with compacted topsoil (hand tamped) and graded to match existing/proposed grades. Any ruts resulting from these operations shall be filled and graded smoothly. No additional compensation will be made for the disposal of the non-salvageable fence materials or the filling of foundation/post holes or ruts.

METHOD OF MEASUREMENT

ADD: The following section:

162-4.6

Traffic detector loops shall be measured in units per each device installed and accepted.

BASIS OF PAYMENT

ADD: The following section:

162-5.6

Payment shall be made at the contract unit price for installation per each new traffic detector loops. This price shall be full compensation for furnishing all materials, labor, equipment, tools, and incidentals necessary to complete the item.

Payment will be made under:

- ITEM AR162530 WALKWAY GATES, CLASS E (5') – PER EACH.**
- ITEM AR162571 DETECTOR LOOP – PER EACH.**
- ITEM AR162905 REMOVE GATE – PER EACH.**

DIVISION VIII – MISCELLANEOUS

ITEM 910975 – RELOCATE ROADWAY SIGN

DESCRIPTION

910-1.1

The work shall consist of relocating existing signs as noted on the plans or as directed by the Engineer on new sign posts.

MATERIALS

910-2.1 SIGN POSTS

Sign post materials shall meet the requirements of Section 729 Metal Post of IDOT's *Standard Specifications for Road and Bridge Construction*. The post shall be Type B as designated on Illinois Department of Transportation Highway Standard 720011 and 729001. Unless otherwise specified, only galvanized posts shall be used.

CONSTRUCTION METHODS

910-3.1

This work shall consist of furnishing and installing metal posts of the size and type specified, utilizing the direct burial methods.

910-3.2

Materials shall meet the requirements of Article 729 of the Standard Specifications for Road and Bridge Construction. Unless otherwise specified, only galvanized posts shall be used. The post shall be Type B as designated on Illinois Department of Transportation Highway Standard 720011 and 729001.

910-3.3

The metal posts may be driven by hand or mechanical means to a minimum depth of 4 feet (Type B) measured from the ground line or as shown in the plans. The post shall be protective by suitable driving cap and if required by the Engineer, the material around the post will be compacted after driving.

Care shall be taken to avoid scratching, chipping, or other damage to polyester or enamel-coated posts during handling and installation. Chips and scratches may be recoated in the field by a method meeting and coating manufacturer's recommendations except that chips and scratches totaling more than 5% of the surface area of any one post and/or more than 5% of the surface area in any one-foot segment of any one post shall be cause for rejection of the post.

If the post specified is too long, the Contractor may choose to cut the post to the required length. Any post so cut shall be installed with the cut end at the bottom.

Sign panels shall be erected in accordance with Illinois Department of Transportation Highway Standards 720001 and 720006.

910-3.4

Existing sign foundation and posts shall be completely removed and disposed of by the Contractor off airport property. Existing signs shall be saved and remain the property of the Airport. The excavations shall be backfilled and compacted per the requirements of Section 152.

METHOD OF MEASUREMENT

910-4.1

This quantity of relocated roadway signs installed to be paid shall be the number, per each sign satisfactorily relocated and installed in accordance with applicable specifications and accepted by the Engineer. Sign posts and supports shall be incidental to this item. No additional compensation shall be made for the additional length of posts required.

BASIS OF PAYMENT

910-5.1

Payment will be made at the contract unit price for RELOCATED ROADWAY SIGN, per each. This price shall be full compensation for all materials and erection of all signs at proposed locations and for all materials, labor and equipment necessary to complete the work as described herein.

Payment will be made under:

ITEM AR910975 RELOCATE ROADWAY SIGN – PER EACH.

IDOT DIVISION OF AERONAUTICS POLICY MEMORANDA

State of Illinois
Department of Transportation
Division of Aeronautics

POLICY MEMORANDUM

December 3, 2020

Springfield

Number: **87-4**

TO: CONSULTING ENGINEERS

SUBJECT: DETERMINATION OF BULK SPECIFIC GRAVITY (d)
OF COMPACTED BITUMINOUS MIXES

- A. SCOPE. This method of test covers the determination of the bulk specific gravity and the percent air, of core samples from compacted bituminous mixtures using a saturated surface-dry procedure.
- B. DEFINITIONS.
1. Bulk Specific Gravity (G_{mb}) ASTM 2726 or density is the weight per unit volume (gms/cc) of a mixture in its existing state of consolidation. The volume measurement for this specific gravity will include the volume of all the aggregate, asphalt, and air spaces (voids) in the aggregate particles and between the aggregate particles.
 2. Theoretical Maximum Specific Gravity (G_{mm}) ASTM 2041 is the weight per unit volume (grams/cc) of a mixture assuming complete consolidation; i.e., all the air spaces (voids) between the aggregate particles are eliminated.
 3. Percent Density is a measure of the degree of compaction in relation to the Theoretical Maximum Specific Gravity.
 4. Percent Air is a measure of the air voids in the compacted pavement.
- C. APPARATUS.
1. Balance - The balance shall be accurate to 0.1 gm throughout the operating range. It may be mechanical or electrical and shall be equipped with a suitable suspension apparatus and holder to permit weighing of the core in water while suspended from the balance. If the balance is a beam type, it shall be set up so that the core is placed in the basket that is suspended from the zero (0) end of the balance arm.
 2. Water bath - The container for immersing the core in water while suspended from the balance shall be equipped with an overflow outlet for maintaining a constant water level. This water bath should be large enough to handle full-depth cores. When testing several cores at the same time, a dish-pan, sink or suitable container may be used for soaking.

D. PROCEDURE.

1. Prior to testing, cores shall be sorted on a flat surface in a cool place. The sample(s) shall be brushed with a wire brush and/or other suitable means, to remove all loose and/or foreign materials, such as seal coat, tack coat, foundation material, soil, paper and foil prior to testing.
2. If a core contains binder and surface or multiple lifts, the lifts shall be separated. This may be done in the following manner:
 - a. Mark the separation line between the two lifts.
 - b. Place the core in a freezer for 20-25 minutes.
 - c. Place a 2 or 3-inch wide chisel on the separation line and tap with a hammer. Rotate the core and continue this process until the core separates. Brush loose pieces with a wire brush if needed.
 - d. Allow 2-3 hours for the core to return to ambient temperature before proceeding.
3. Prepare the water baths for soaking and weighing with water at 77^o F. Water baths should be maintained at this temperature throughout testing. Saturate the cores by submerging in the water for a minimum of 20 minutes.
4. With the balance and water bath properly assembled and zeroed, suspend the sample from the balance and submerge it in the water bath. The core must be placed with the original top and bottom in a vertical position. If necessary, add sufficient water to bring the water level up to the overflow outlet. Permit any excess to overflow. Read and record the Saturated Submerged Weight. Designate this weight as (C).
5. Remove the core from the water bath and blot the excess water from the surface of the core with an absorbent cloth or other suitable material. This must be done quickly to prevent the internal water from escaping.
6. Place the core on the balance and read and record the Saturated Surface-dry Weight in air. Designate this weight as (B).
7. Place the core in a tared pan and dry in an oven. When the core is dry (less than 0.5 gm loss in one hour), record the weight and subtract the pan weight. Designate this weight as (A).

8. The following calculation is used to determine the Bulk Specific Gravity of the core.

$$G_{mb} = \frac{A}{B - C}$$

G_{mb} = Bulk Specific Gravity
A = Oven dry weight
B = Saturated surface-dry weight
C = Saturated submerged weight

- E. PERCENT DENSITY. The following calculation is used to determine the percent density of the core:

$$\% \text{ Density} = 100 \times \frac{G_{mb}}{G_{mm}}$$

G_{mb} = Bulk Specific Gravity
 G_{mm} = Theoretical Maximum Gravity*

Note: The Theoretical Maximum Gravity (G_{mm}) is determined from the mix design until current Vacuum Pycnometer test are available.

- F. PERCENT AIR. To calculate the percent air, use the following formula:

$$\% \text{ Air} = 100 - \% \text{ Density}$$

- G. WEIGHT PER SQUARE YARD OF COMPACTED MIXTURE. The actual weight per square yard of a compacted mixture can be calculated by using the Bulk Specific Gravity (G_{mb}). The volume of a square yard of pavement one (1) inch thick is 0.75 cubic foot. Taking the weight of a cubic foot of water as 62.37 pounds, one square yard of compacted material, one (1) inch thick weighs:

$$\text{Pounds / Sq. Yd. (1" thick)} = 0.75 \times 62.37 \times G_{mb}$$

Alan D. Mlacnik, P.E.
Bureau Chief of Airport Engineering

Supersedes Policy Memorandum 87-4, dated February 20, 2014

State of Illinois
Department of Transportation
Division of Aeronautics

POLICY MEMORANDUM

March 28, 2022

Springfield

Number 96-1A

TO: CONSULTING ENGINEERS

SUBJECT: FOR AERONAUTICS 2020 STANDARD SPECIFICATIONS,
ITEM 610, STRUCTURAL PORTLAND CEMENT CONCRETE:
JOB MIX FORMULA APPROVAL & PRODUCTION TESTING.

- I. This policy memorandum addresses the Job Mix Formula (JMF) approval process and production testing requirements when Item 610 is specified for an airport construction contract.
- II. PROCESS
 - a. The contractor may submit a mix design with recent substantiating test data, or he may submit a mix design generated by the Illinois Division of Highways with recent substantiating test data for approval consideration. The mix design should be submitted to the Resident Engineer. An Item 501 PCC Pavement mix can be used in lieu of a Class SI mix, with the approval of the Division.
 - b. The Resident Engineer should verify that each component of the proposed mix meets the requirements set forth under Item 610 of the *2020 Standard Specifications for Construction of Airports* and/or the contract special provisions.
 - c. The mix design should also indicate the following information:
 1. The name, address, and producer/supplier number for the concrete.
 2. The source, producer/supplier number, gradation, quality, and SSD weight for the proposed coarse and fine aggregates.
 3. The source, producer/supplier number, type, and weight of the proposed flyash and/or cement.
 4. The source, producer/supplier number, dosage rate or dosage of all admixtures.
 - d. After completion of Items b and c above, the mix with substantiating test data shall be forwarded to the Division of Aeronautics for approval. Once the mix has been approved, the production testing shall be at the rate in Section III as specified herein.

III. PRODUCTION TESTING

- a. When directed by the Resident Engineer, the Contractor shall make, cure and store one set of cylinders in accordance with AASHTO T23 for acceptance testing for each day the mix is used. In addition, at least one slump, one mix temperature, and one air test shall be conducted for each day the mix is used.
- b. The concrete shall have a maximum slump of four inches (4") and minimum slump of two inches (2") when tested in accordance with AASHTO T119.
- c. The air content of the concrete shall be between 5% and 8% by volume when tested in accordance with AASHTO T152.
- d. At no time shall the temperature of the concrete exceed 90 degrees Fahrenheit.
- e. Acceptance testing for concrete provided under this item shall have a 14-day compressive strength of not less than 3,500 psi when tested in accordance with AASHTO T22. The testing lab shall be IDOT or AASHTO approved. The Resident Engineer will be responsible for the strength tests on the specimens at no expense to the contractor.
- f. If more than 100 cubic yards of the mix is placed in a given day, additional tests at a frequency of 1 per 100 cubic yards shall be taken for strength, slump, mix temperature, and air.
- g. The Resident Engineer shall collect actual batch weight tickets for every batch of Item 610 concrete used for the project. The actual batch weight tickets shall be kept with the project records and shall be available upon request of the Department of Transportation.

William C. Eves, P.E.
Acting Chief Engineer

Supersedes Policy Memorandum 96-1 (2020) dated December 3, 2020

State of Illinois
Department of Transportation
Division of Aeronautics

POLICY MEMORANDUM

December 3, 2020

Springfield, Illinois

Number 96-3

TO: CONSULTING ENGINEERS

SUBJECT: REQUIREMENTS FOR QUALITY ASSURANCE ON PROJECTS
WITH BITUMINOUS CONCRETE PAVING

I. SCOPE

The purpose of this policy memorandum is to define to the Consulting Engineer the requirements concerning Quality Assurance on bituminous concrete paving projects. Specifically, this memo applies whenever the Contractor is required to comply with the requirements set forth in Policy Memorandum 2003-1, "*Requirements for Laboratory, Testing, Quality Control, and Paving of Bituminous Concrete Mixtures*".

II. LABORATORY APPROVAL

The Resident Engineer shall review and approve the Contractor's plant laboratory to assure that it meets the requirements set forth in the contract specifications and Policy Memorandum 2003-1. This review and approval shall be completed prior to utilization of the plant for the production of any mix.

III. QUALITY ASSURANCE DURING PRODUCTION PAVING

A. The R.E. shall perform sample tests at a rate of 1/5000 tons randomly selected by the R.E. and shall be sent with an identification sheet (Form AER 24, Sample Identification) to an ASTM certified independent laboratory. designated by the Division of Aeronautics. If the project is < 5000 tons, 1 sample selected randomly shall be sent.

Sample preparation, sample size and number of samples shall be according to Policy Memorandum, "*HMA Comparison Samples*".

B. At the option of the Engineer, additional independent assurance tests may be performed on split samples taken by the Contractor for Quality Control testing. In addition, the Resident Engineer shall witness the sampling and splitting of these samples at the start of production and as needed throughout mix production. The Engineer may select any or all split samples for assurance testing. These tests may be performed at any time after sampling. The test results will be made available to the Contractor as soon as they become available.

C. The Resident Engineer may witness the sampling and testing being performed by the Contractor. If the Resident Engineer determines that the sampling and Quality Control tests are not being performed according to the applicable test procedures, the Engineer may stop production until corrective action is taken. The Resident Engineer will promptly notify the Contractor, both verbally and in writing, of observed deficiencies. The Resident Engineer will document all witnessed samples and tests. The Resident Engineer may elect to obtain samples for testing, separate from the Contractor's Quality Control process, to verify specification compliance.

1. Differences between the Contractor's and the Engineer's split sample test results will be considered acceptable if within the following limits:

<u>Test Parameter</u>	<u>Acceptable Limits of Precision</u>
% Passing	
1/2 in.	5.0 %
No. 4	5.0 %
No. 8	3.0 %
No. 30	2.0 %
No. 200	2.2 %
Asphalt Content	0.3 %
Maximum Specific Gravity (G_{mm}) of Mixture	0.026
Bulk Specific Gravity (G_{mb}) of Gyratory Brix	0.045

2. In the event a comparison of the required plant test results is outside the above acceptable limits of precision, split or independent samples fail the control limits, an extraction indicates non-specification mix, or a continual trend of difference between Contractor and Engineer test results is identified, the Engineer will immediately investigate. The Engineer may suspend production while the investigation is in progress. The investigation may include testing by the Engineer of any remaining split samples or a comparison of split sample test results on the mix currently being produced. The investigation may also include review and observation of the Contractor's technician performance, testing procedure, and equipment. If a problem is identified with the mix, the Contractor shall take immediate corrective action. After corrective action, both the Contractor and the Engineer shall immediately resample and retest.

- C. The Contractor shall be responsible for documenting all observations, records of inspection, adjustments to the mixture, test results, retest results, and corrective actions in a bound hardback field book or bound diary which will become the property of IDA upon completion and acceptance of the project. The Contractor shall be responsible for the maintenance of all permanent records whether obtained by the Contractor, the Contractor's Consultants, or the producer of bituminous mix material. The Contractor shall provide the Engineer full access to all documentation throughout the progress of the work.

Results of adjustments to mixture production and tests shall be recorded in duplicate and sent to the Engineer.

IV. ACCEPTANCE BY ENGINEER

Density acceptance shall be performed according to the Standard Specifications for Construction of Airports, section 401-6.1 or according to the acceptance procedure outlined in the Special Provisions.

Alan D. Mlacnik, P.E.
Bureau Chief of Airport Engineering

Supersedes Policy Memorandum 96-3, dated February 20, 2014

State of Illinois Department of
Transportation Division of
Aeronautics

POLICY MEMORANDUM

December 3, 2020

Springfield, Illinois

Number 97-2

TO: CONSULTING ENGINEERS

SUBJECT: PAVEMENT MARKING PAINT AND GLASS BEADS ACCEPTANCE

I. SCOPE

The purpose of this policy memorandum is to define the procedure for acceptance of pavement marking paint and glass beads.

II. RESIDENT ENGINEER'S DUTIES

The Resident Engineer shall follow the acceptance procedure outlined as follows:

- A. Require the contractor to furnish the name of the paint and glass beads manufacturer, IDOT Test I.D. number and the Batch/Lot number proposed for use prior to beginning work. Notify the I.D.A. Materials Certification Engineer when this information is available.
- B. Require the manufacturer's certification before painting begins. Check the certification for compliance to the contract specifications.
 1. The certification shall be issued from the manufacturer and shall include the specification and the batch number.
 2. The paint containers shall have the manufacturer's name, the specification and the batch number matching the certification.
- C. If no batch number is indicated on the certification or containers, sample the paint according to the procedure for the corresponding paint type.
- D. If the I.D.A. Engineer of Materials indicates that batch number has not been previously sampled and tested, sample the paint according to the procedure for the corresponding paint type. The Division of Aeronautics will provide paint cans upon request by the Resident Engineer. Samples will only be taken in new epoxy lined cans and lids so that the paint will not be contaminated. It is important to seal the sample container immediately with the paint can lid to prevent the loss of volatile solvents.

Mark the sample cans with the paint color, manufacturer's name, and batch number. The paint samples and manufacturer's certification shall be placed in the mail or delivered within 24 hours after sampling. Address or deliver the samples to the Material's Certification Engineer at:

Illinois Department of Transportation
Division of Aeronautics
One Langhorne Bond Drive
Springfield, Illinois 62707

Sampling Procedures for Each Paint Type:

1. Waterborne or Solvent Base Paints
 - a. A sample consists of one-pint cans taken per batch number. Before drawing samples, the contents of the component's container must be thoroughly mixed to make certain that any settled portion is fully dispersed.
 - b. Be sure to indicate to the contractor that acceptance of material is based upon a passing test of the paint material.
2. Epoxy Paint
 - a. Take separate one-pint samples of each paint component prior to marking. Before drawing samples, the contents of each component's container must be thoroughly mixed to make certain that any settled portion is fully dispersed. **Do not combine the two components or sample from the spray nozzle.**
 - b. Be sure to indicate to the contractor that acceptance of material is based upon a passing test of the paint material.

III. TESTING

The paint will be tested for acceptance by the IDOT Bureau of Materials and Physical Research for conformance to the contract specifications.

Alan D. Mlacnik, P.E.
Bureau Chief of Airport Engineering

Supersedes policy memorandum 97-2 dated June 22, 2018

State of Illinois
Department of Transportation
Division of Aeronautics

POLICY MEMORANDUM

December 3, 2020

Springfield, Illinois

Number 2003-1

TO: CONSULTANTS & CONTRACTORS

SUBJECT: REQUIREMENTS FOR LABORATORY, TESTING, QUALITY CONTROL, AND PAVING OF SUPERPAVE HMA CONCRETE MIXTURES FOR AIRPORTS

I. SCOPE

The purpose of this policy memorandum is to define to the Contractor the requirements concerning the laboratory, testing, Quality Control, and paving of HMA mixtures utilizing Superpave technology. References are made to the most recent issue of the Standard Specifications for Construction of Airports (Standard Specifications) and to American Society for Testing and Materials (ASTM), American Association of State Highway and Transportation Officials (AASHTO) and IDOT Bureau of Materials Illinois Lab Procedure (ITP) testing methods. The Quality Assurance and acceptance responsibilities of the Resident Engineer are described in Policy Memorandum 96-3.

II. LABORATORY

The Contractor shall provide a laboratory located, at the plant, according to the current Illinois Department of Transportation, Bureau of Materials Policy Memorandum (PM) 6-08, *Minimum Private Laboratory Requirements for Construction Materials Testing or Mix Design*. The laboratory shall be of sufficient size and be furnished with the necessary equipment and supplies for adequately and safely performing the Contractor's Hot Mix Asphalt (HMA) Job Mix Formula (JMF), Quality Control (QC) testing and Quality Assurance (QA) testing. The laboratory and equipment furnished by the Contractor shall be properly calibrated and maintained. The Contractor shall maintain a record of calibration results at the laboratory. The Engineer may inspect measuring and testing devices at any time to confirm both calibration and condition. If the Engineer determines that the equipment is not within the limits of dimensions or calibration described in the appropriate test method, he may stop production until corrective action is taken. If laboratory equipment becomes inoperable or insufficient to keep up with mix production testing, the Contractor shall cease mix production until adequate and/or sufficient equipment is provided.

III. MIX DESIGN SUBMITTAL

Based upon data and test results submitted by the Contractor, the Illinois Division of Aeronautics (IDA) Engineer of Construction & Materials shall issue the final Job Mix Formula (JMF) approval letter that concurs or rejects the Contractor's proposed JMF. The Contractor will be required to perform the sampling and laboratory testing and develop a complete mix design, according to the following guidelines: Mix design submittals should be submitted to IDA, Construction/Material Section, Attn: Certification and Mixtures Engineer. Note: Quality Control (QC) Managers shall

be Level III QC/QA qualified and will be responsible for all mix designs. All Technicians obtaining samples and performing gradations shall have successfully completed the IDOT Mixture Aggregate Technician Course and Technicians performing mix design testing and plant sampling/testing shall have successfully completed the IDOT Bituminous Concrete Level 1 Technician Course under the Illinois Department of Transportation, Bureau of Materials & Physical Research QC/QA Training Program.

A. Initial Mix Design Submittal

1. Use the first tab/page of the IDOT, QC/QA Package, Mix Design Software spreadsheet workbook. Provide the Producer name, Producer # and Producer location of each aggregate and asphalt binder (AB). Producers are assigned Producer numbers by IDOT Central Bureau of Materials.
2. Material code for each aggregate.
3. Aggregate Gradations per ASTM C-136 (The Contractor shall obtain representative samples of each aggregate).
4. Material code for each aggregate (i.e. 022CM11, etc.).
5. Material code for the grade of AB.
6. Proposed Aggregate Blend (% for each aggregate) Note: Based on the gradation results, the Contractor shall select the blend percentages that comply with the Standard Specifications, Section 401/403 – 3.3 (Table: Aggregate – Asphalt Pavements)
7. Producer name, Producer #, and specific gravity of the proposed asphalt cement.
8. IDOT approved Performance Grade (PG) Binder shall be used unless otherwise specified by the IDA Engineer of Construction & Materials.

After verification and approval by IDA of the proposed design information from this Section A, Initial Mix Design Submittal, the Contractor shall proceed to Section B, Mixture Design and Testing, and perform mixture tests on 4 gyratory brix sample (4 point mix design) to determine the optimum AB content for the target Air Voids.

Note: If Section A, Initial Mix Design Submittal, is not performed first, and the complete mix design (gyratory testing) is submitted with an unapproved material source or an incorrect aggregate blend, then the gyratory laboratory testing would have to be re-done.

B. Preliminary Mixture Design & Testing

Design Parameters

Gyrations (N_{des}) – per Standard Specifications for Construction of Airports (Standard Specifications), Section 401/403 – 3.3 (JMF), Table (Asphalt Design Criteria)

Asphalt Content – AC% per Standard Specifications, Section 401/403 – 3.3 (JMF), Table (Aggregate – Asphalt Pavements)

Maximum Specific Gravity – G_{mm} (AAHSTO T 209)

Bulk Specific Gravity – G_{mb} (AAHTO T 166)

% air voids – V_a (ASTM D3203) per Standard Specifications, Section 401/403 – 3.3 Table (Asphalt Design Criteria)

VFA % – per Standard Specifications, Section 401/403 – 3.2 (JMF), Table (Asphalt Design Criteria)

C. Preliminary Mix Design Submittal

The Preliminary JMF including all test results shall be submitted to IDA, Construction/Material Section, Attn: Certification and Mixtures Engineer with the following data:

- a) Aggregate & asphalt cement material codes
- b) Aggregate & asphalt cement producer numbers, names, and locations
- c) Percentage of each individual aggregate
- d) Aggregate blend % for each sieve
- e) AC Specific Gravity
- f) Bulk Specific Gravity and Absorption for each aggregate
- g) Summary of Superpave Design Data: AC % Mix, G_{mb} , G_{mm} , VMA, Voids (Total Mix), Voids Filled, V_{be} , P_{be} , P_{ba} , G_{se}
- h) Optimum design data listing: AC % Mix, G_{mb} , G_{mm} , VMA, Voids (Total Mix), Voids Filled, G_{se} , G_{sb}
- i) Percent of asphalt that any RAP will add to the mix
- j) Graphs for the following: Gradation on 0.45 Power Curve, AC vs. Voids (Total Mix), AC vs. Specific Gravities, AC vs. Voids Filled, AC vs. VMA
- k) Tensile Strength Ratio (TSR)
- l) Type and amount of anti-strip agent when used
- m) Date the JMF was developed

D. Mix Approval

Once the preliminary JMF is reviewed and approved by IDA, a JMF approval letter will be issued to the consultant and contractor. Production of HMA is not authorized until a JMF letter has been issued.

E. Change in Material Sources

The above procedure, III. MIX DESIGN SUBMITTAL, shall be repeated for each change in material source or gradation of aggregate materials.

IV. MIX PRODUCTION TESTING

The Quality Control (QC) of the manufacture and placement of HMA mixtures is the responsibility of the Contractor and will be according to the Standard Specifications, Section 401/403-5.1 - 5.6. In addition, the Contractor shall develop a Contractor Quality Control Program (CQCP) in accordance with Item 100 in the Standard Specifications. The (CQCP) shall be submitted on the Form AER 27, Hot Mix Asphalt (HMA) Quality Control Plan. The Contractor shall perform or have performed the inspection and tests required to assure conformance to contract requirements. Quality Control includes the recognition of defects and their immediate correction. This may require increased testing, communication of test results to the plant or the job site, modification of operations, suspension of HMA production, rejection of material, or other actions as appropriate. The Resident Engineer shall be immediately notified of any failing tests and subsequent remedial action. Form AER-14 shall be reported to IDA, Construction/Material Section, Attn: Certification and Mixtures Engineer and the Resident Engineer no later than the start of the next workday. The Contractor shall provide a Quality Control (QC) Manager who will have overall responsibility and authority for Quality Control. This individual shall have successfully completed the IDOT Division of Highways HMA Concrete Level II Technician Course "HMA Proportioning and Mixture Evaluation." In addition to the QC Manager, the Contractor shall provide sufficient and qualified personnel to perform the required visual inspections, sampling, testing, and documentation in a timely manner.

V. TEST SECTION (Note: Applies for Method II only ($\geq 2,000$ tons/pay item))

The purpose of the test section is to determine if the mix is acceptable and can be compacted to a consistent passing density. The test strip construction and acceptance will be according to the Standard Specifications, Section 401/403-3.5.

VI. MATERIAL ACCEPTANCE

Material acceptance and acceptance sampling to determine conformance to the contract specifications will be performed by the Resident Engineer in accordance with the Standard Specifications, Section 401/403-6.1. In addition to the requirements set forth in Section 401/403-6.1 the R.E. shall perform sample tests at a rate of 1/5000 tons randomly selected by the R.E. and shall be sent with an identification sheet (Form AER 24, Sample Identification) to an ASTM certified independent laboratory. If the project is < 5000 tons, 1 sample selected randomly shall be sent.

Alan D. Mlacnik, P.E.
Bureau Chief of Airport Engineering

Supersedes Policy Memorandum 2003-1 dated June 12, 2004

IDOT STANDARD DRAWINGS

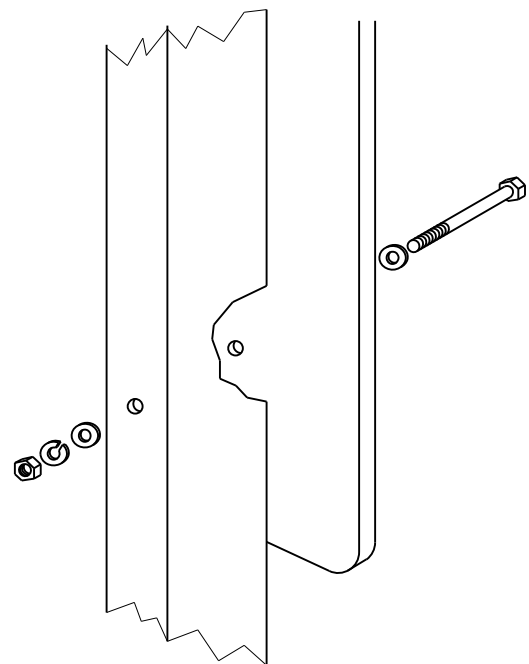

Sign panel 36 (900) wide or less

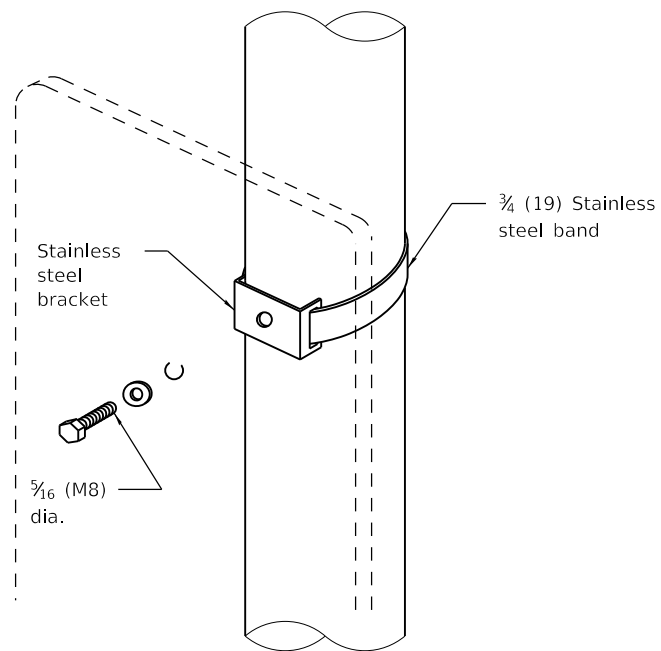

Sign panel 36 (900) wide or less

Section modulus (minimum)	Axis A	Axis B
Steel	0.050 in. ³ (819 mm ³)	0.105 in. ³ (1720 mm ³)
Aluminum	0.150 in. ³ (2458 mm ³)	0.315 in. ³ (5162 mm ³)

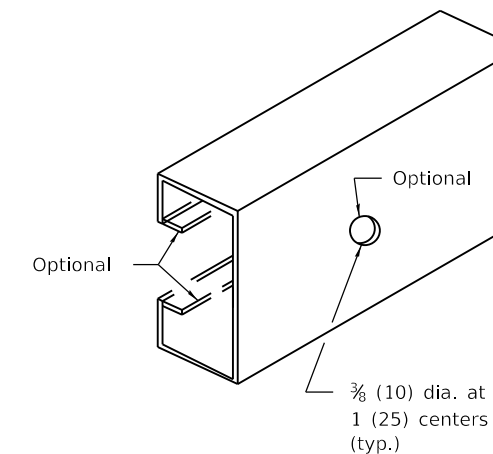
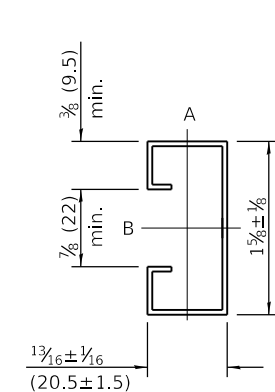

SUPPORTING CHANNEL DETAILS

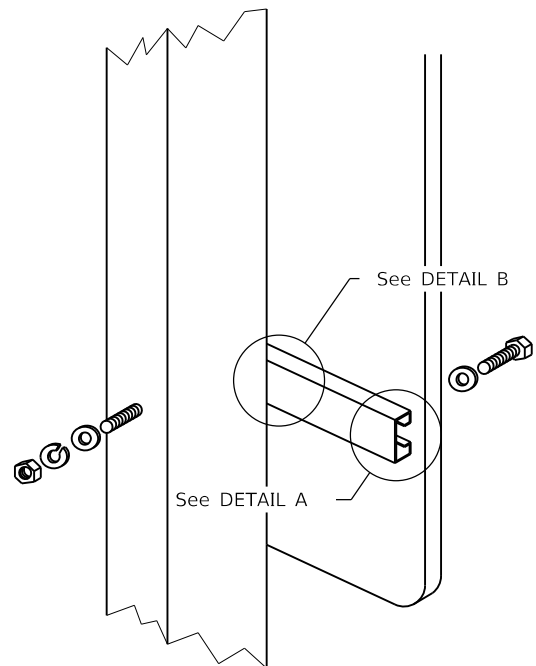

Sign panel over 36 (900) wide

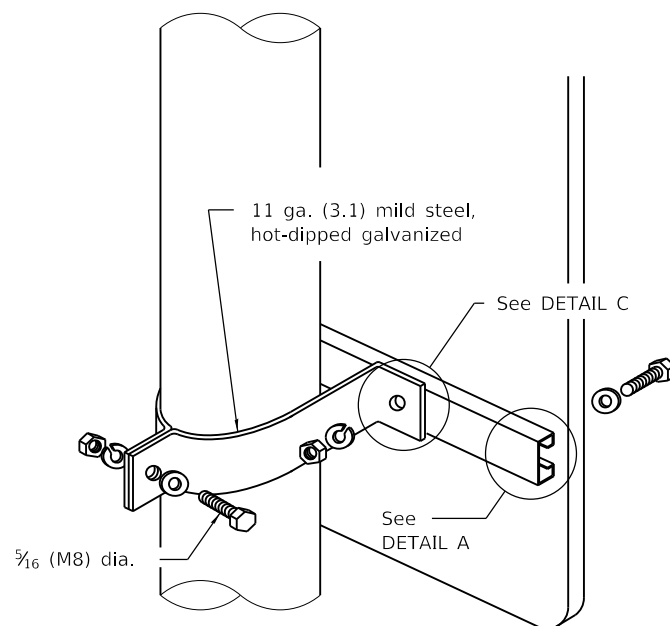

Sign panel over 36 (900) wide

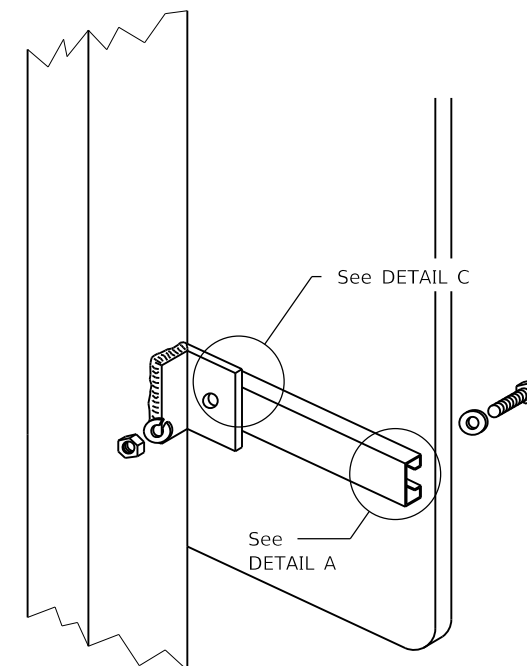

ROUTE MARKER ASSEMBLY

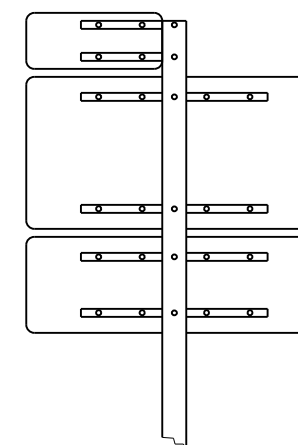

WOOD OR TELESCOPING STEEL POSTS

LIGHT OR SIGNAL STANDARDS

BREAKAWAY STEEL TUBING POSTS
(All sign panel sizes)

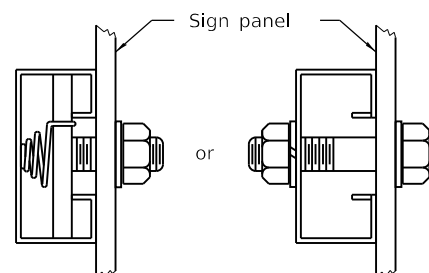

DETAIL A

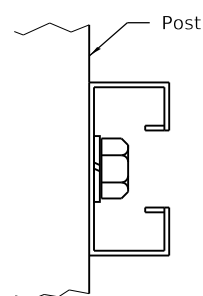

DETAIL B

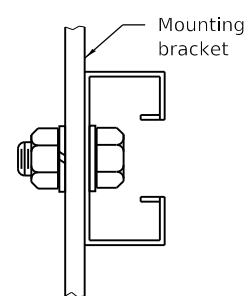

DETAIL C

All dimensions are in inches (millimeters) unless otherwise shown.

DATE	REVISIONS
1-1-09	Switched units to English (metric).
1-1-97	Renum. Standard 2319-6.

SIGN PANEL MOUNTING DETAILS

STANDARD 720001-01

Illinois Department of Transportation

PASSED January 1, 2009
[Signature]
 ENGINEER OF OPERATIONS

APPROVED January 1, 2009
[Signature]
 ENGINEER OF DESIGN AND ENVIRONMENT

ISSUED 1-1-97

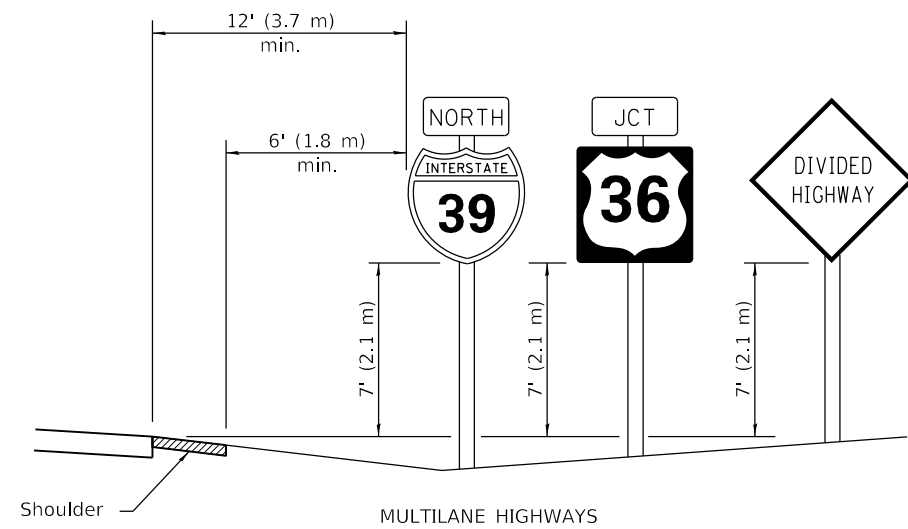

MULTILANE HIGHWAYS

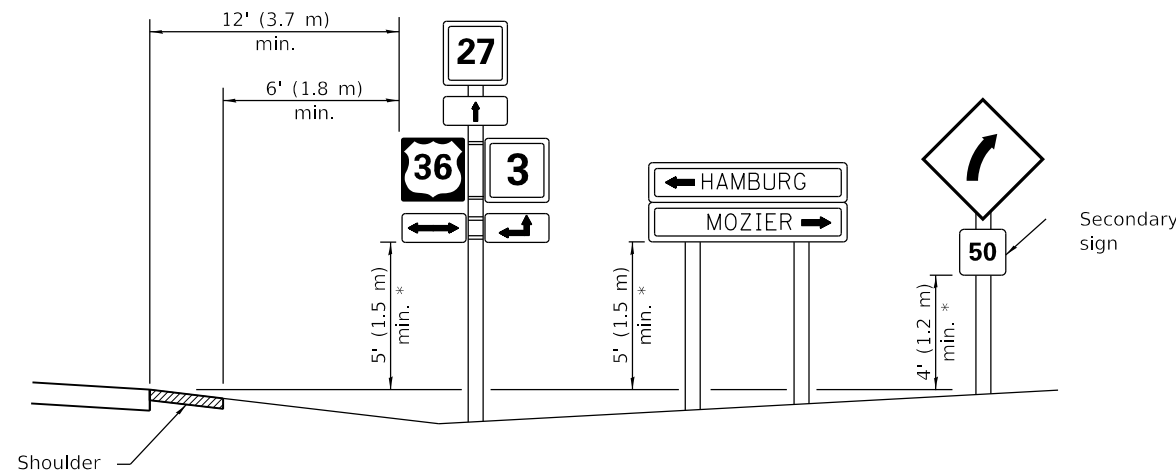

* In any area where parking is likely to occur or where there are obstructions to view or where signs are located over sidewalks, the height shall be at least 7' (2.1 m).

TWO LANE RURAL HIGHWAYS

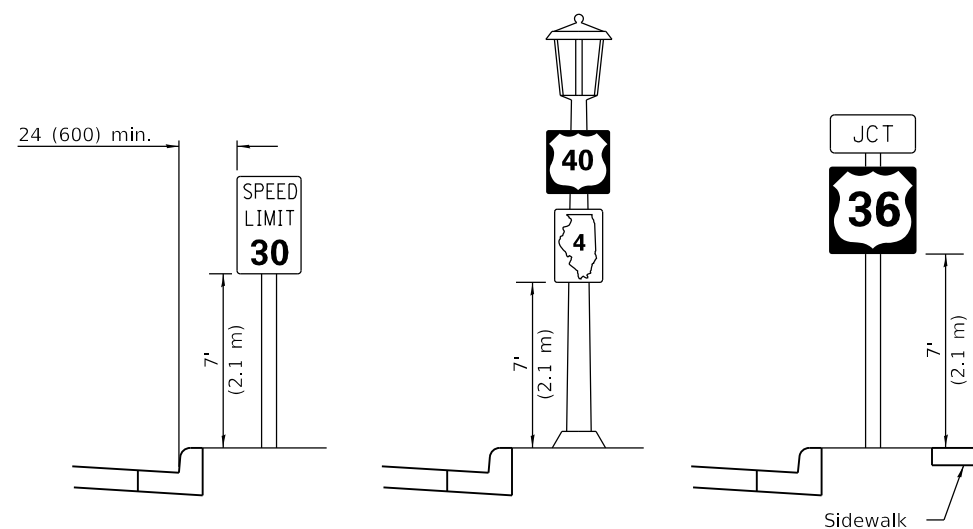

URBAN LOCATIONS

TYPICAL INSTALLATIONS

Signs in any area shall be erected to a uniform height above the edge of the pavement.

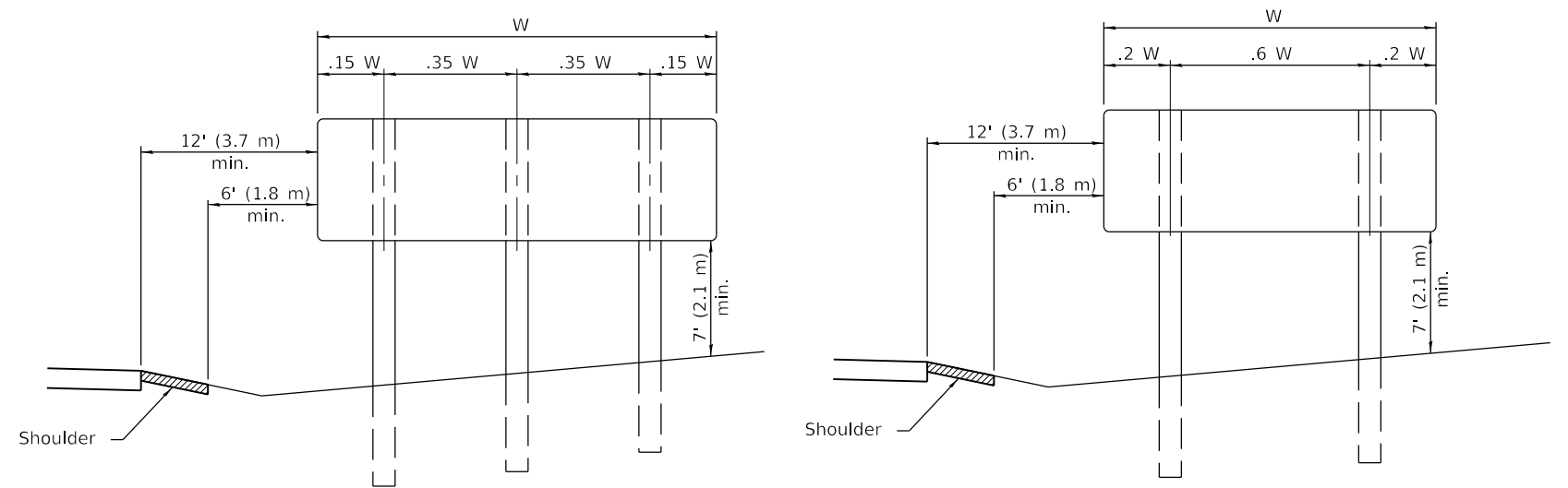

POST SPACING FOR NON-FREEWAY SIGN PANELS

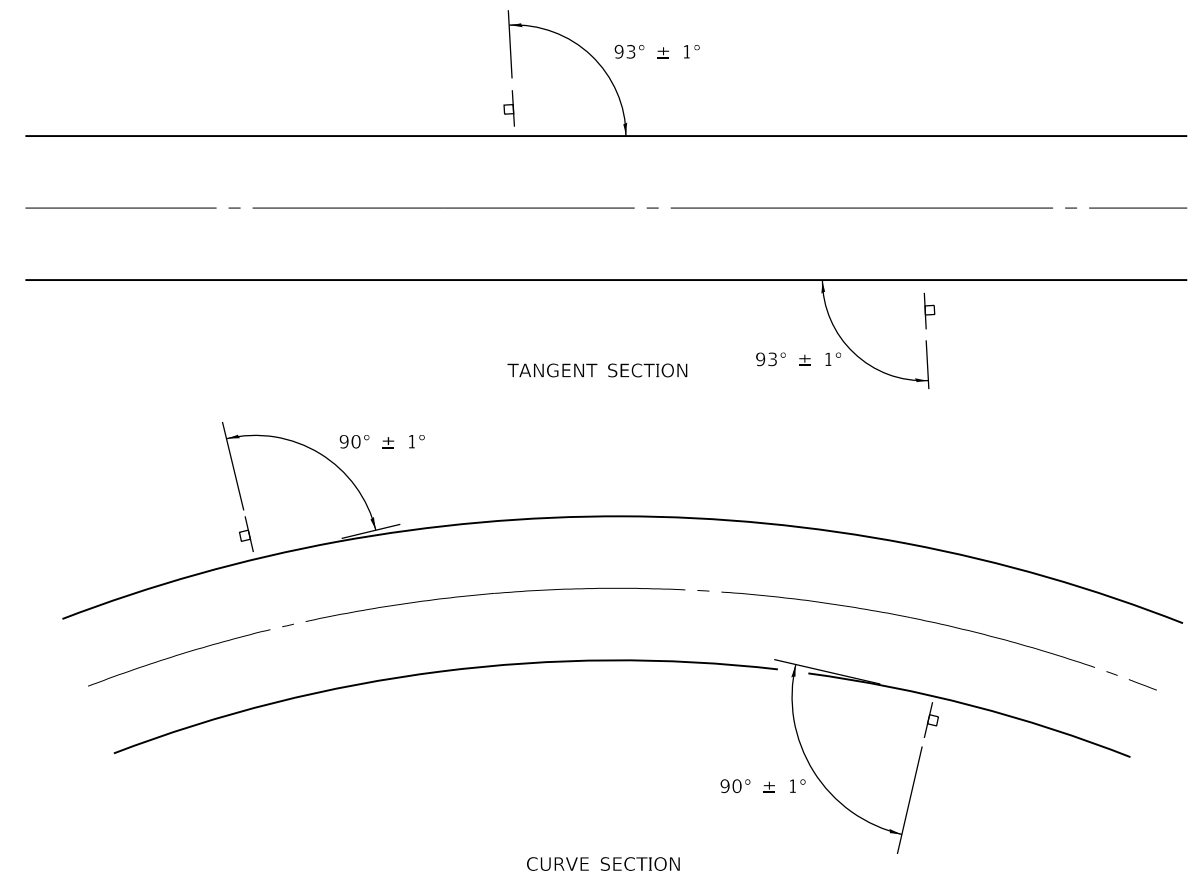

GROUND MOUNT SIGN POSITIONING

All dimensions are in inches (millimeters) unless otherwise shown.

Illinois Department of Transportation

PASSED January 1, 2014
Justin Mann
 ENGINEER OF OPERATIONS

APPROVED January 1, 2014
[Signature]
 ENGINEER OF DESIGN AND ENVIRONMENT

ISSUED 1-1-97

DATE	REVISIONS
1-1-14	Added shoulders and slopes.
	Changed sign distances from roadway and shoulder.
1-1-12	Rev. sign elev. for multilane hwy's. Revised sign elev. and dist. to curb for rural loc.

SIGN PANEL ERECTION DETAILS

STANDARD 720006-04

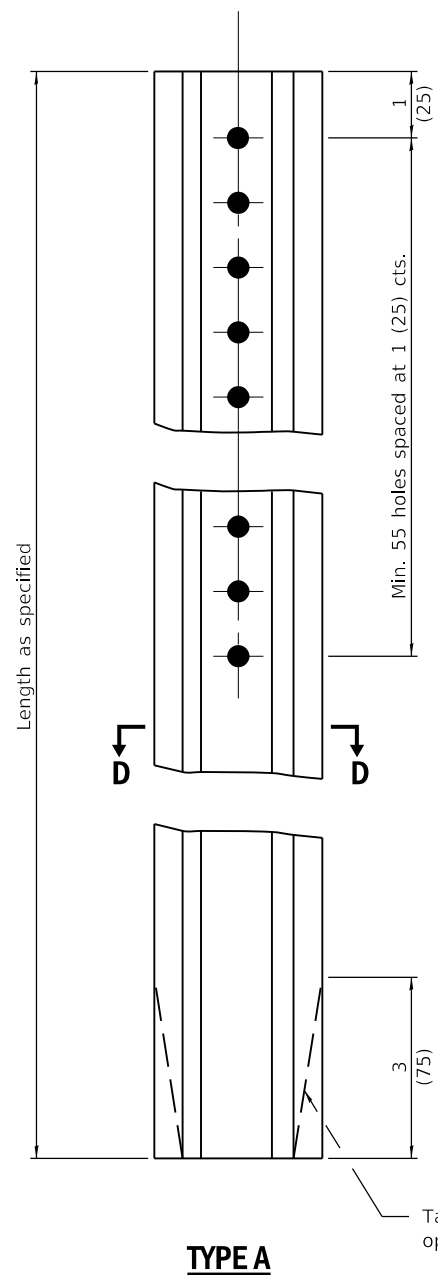

TYPE A

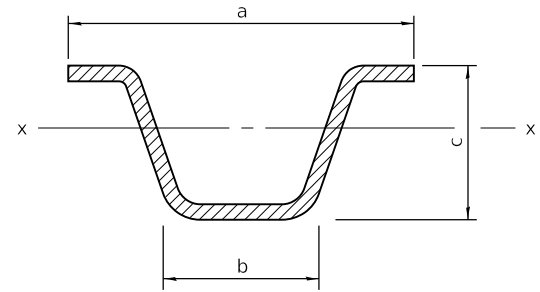

SECTION D-D

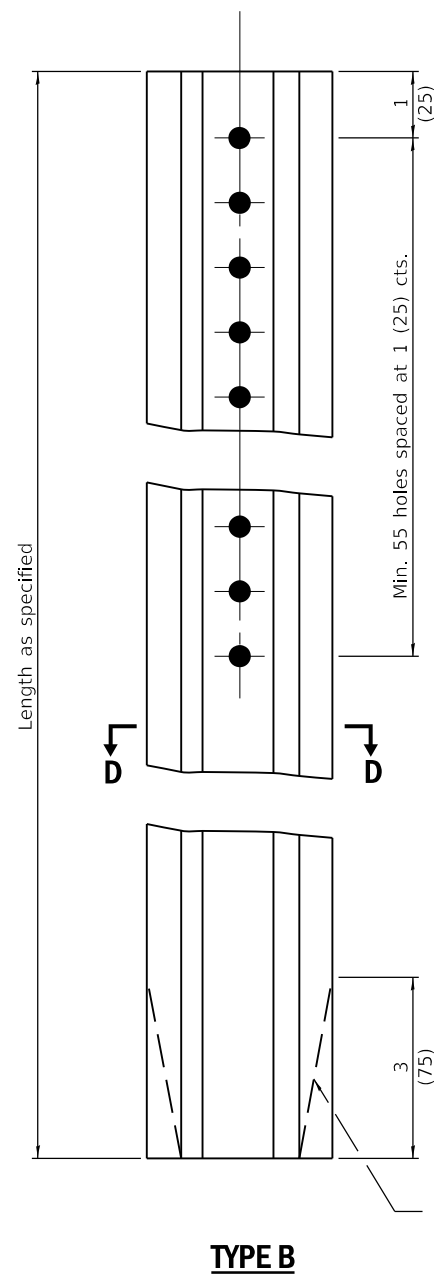

TYPE B

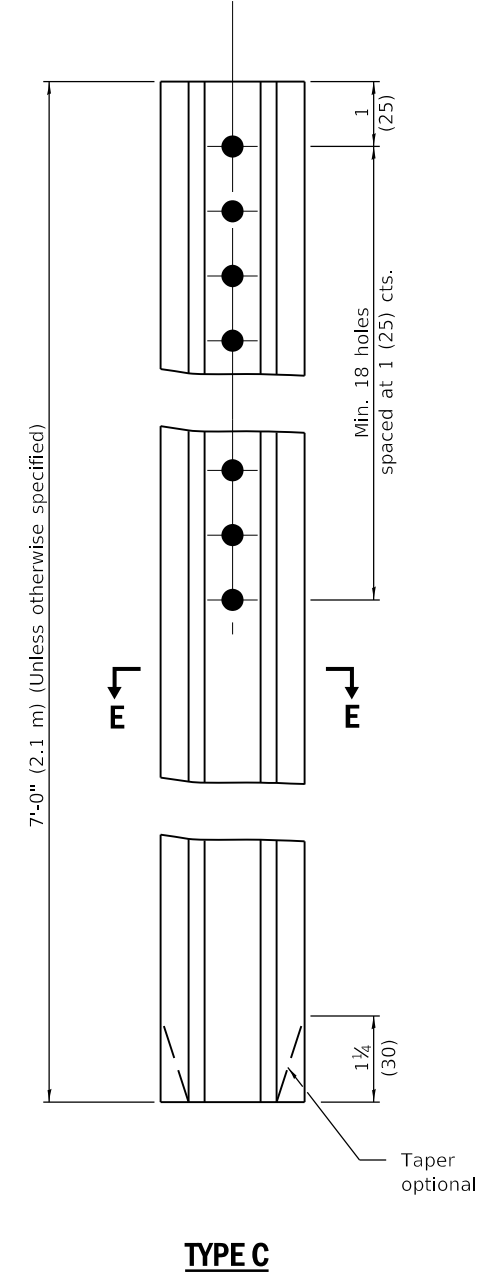

TYPE C

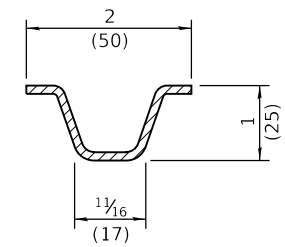

SECTION E-E

Steel - 1.12 lbs./ft. (1.67 kg/m)

		a	b	c	Sx-x in. ³ (mm ³)	lbs./ft. (kg/m)
TYPE A	Steel	3 1/16 (78)	1 1/2 (32)	1 1/16 (37)	0.223 (3,654)	2.00 (2.98)
	Aluminum	3 1/2 (89)	1 1/2 (41)	1 1/2 (48)	0.435 (7,128)	0.90 (1.34)
TYPE B	Steel	3 3/16 (81)	1 1/2 (32)	1 1/2 (38)	0.341 (5,588)	3.00 (4.46)
	Aluminum	4 3/8 (118)	2 1/2 (57)	2 3/8 (60)	0.888 (14,552)	1.30 (1.93)

GENERAL NOTES

Dimensions shown for cross sections are minimum.

All holes are 3/8 (10).

Sx-x is the minimum section modulus about the x-x axis of the post as shown. For posts in which holes are punched or drilled for more than half their length, Sx-x shall be computed for the net section.

All dimensions are in inches (millimeters) unless otherwise shown.

DATE	REVISIONS
1-1-09	Switched units to English (metric).
1-1-97	Renum. Standard 2350-4.

**METAL POSTS FOR SIGNS,
MARKERS & DELINEATORS**

STANDARD 720011-01

Illinois Department of Transportation

PASSED January 1, 2009

ENGINEER OF POLICY AND PROCEDURES

APPROVED January 1, 2009

ENGINEER OF DESIGN AND ENVIRONMENT

ISSUED 1-1-97

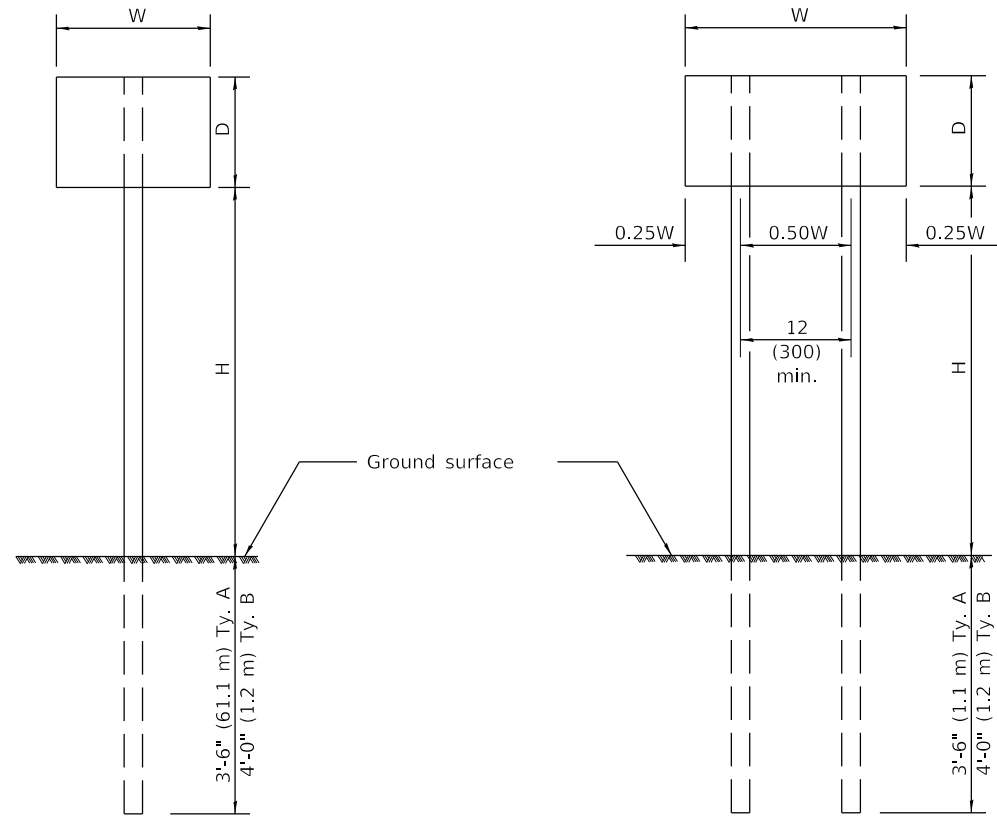

ONE POST INSTALLATION

TWO POST INSTALLATION

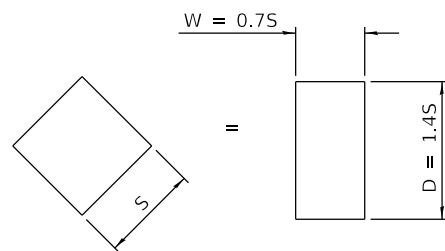

For diamond shaped sign with side S as shown, use required post size for a sign with $W = 0.7S$ and $D = 1.4S$.

SIGN DEPTH (D)	H	NO. AND TYPE OF POST FOR SIGN WIDTH (W)				
		12 (300)	18 (450)	24 (600)	30 (750)	36 (900)
18 (450)	5'-0" (1.5 m)	A	A	A	A	A
	5'-6" (1.7 m)	A	A	A	A	A
	6'-0" (1.8 m)	A	A	A	A	B
	6'-6" (2.0 m)	A	A	A	A	B
	7'-0" (2.1 m)	A	A	A	A	B
	7'-6" (2.3 m)	A	A	A	A	B
	8'-0" (2.4 m)	A	A	A	A	B
	9'-0" (2.7 m)	A	A	A	B	B
24 (600)	5'-0" (1.5 m)	A	A	A	A	B
	5'-6" (1.7 m)	A	A	A	A	B
	6'-0" (1.8 m)	A	A	A	B	B
	6'-6" (2.0 m)	A	A	A	B	B
	7'-0" (2.1 m)	A	A	A	B	B
	7'-6" (2.3 m)	A	A	A	B	B
	8'-0" (2.4 m)	A	A	A	B	2A
	9'-0" (2.7 m)	A	A	B	B	2A
30 (750)	5'-0" (1.5 m)	A	A	A	B	B
	5'-6" (1.7 m)	A	A	A	B	2A
	6'-0" (1.8 m)	A	A	A	B	2A
	6'-6" (2.0 m)	A	A	A	B	2A
	7'-0" (2.1 m)	A	A	B	B	2A
	7'-6" (2.3 m)	A	A	B	B	2A
	8'-0" (2.4 m)	A	A	B	B	2A
	9'-0" (2.7 m)	A	A	B	2A	2A
36 (900)	5'-0" (1.5 m)	A	A	B	B	2A
	5'-6" (1.7 m)	A	A	B	B	2A
	6'-0" (1.8 m)	A	A	B	B	2A
	6'-6" (2.0 m)	A	A	B	2A	2A
	7'-0" (2.1 m)	A	A	B	2A	2A
	7'-6" (2.3 m)	A	A	B	2A	2A
	8'-0" (2.4 m)	A	B	B	2A	2A
	9'-0" (2.7 m)	A	B	2A	2A	2B
4'-0" (1.2 m)	5'-0" (1.5 m)	A	A	B	2A	2A
	5'-6" (1.7 m)	A	B	B	2A	2A
	6'-0" (1.8 m)	A	B	B	2A	2A
	6'-6" (2.0 m)	A	B	2A	2A	2B
	7'-0" (2.1 m)	A	B	2A	2A	2B
	7'-6" (2.3 m)	A	B	2A	2B	2B
	8'-0" (2.4 m)	A	B	2A	2B	2B
	9'-0" (2.7 m)	B	2A	2B	2B	2B

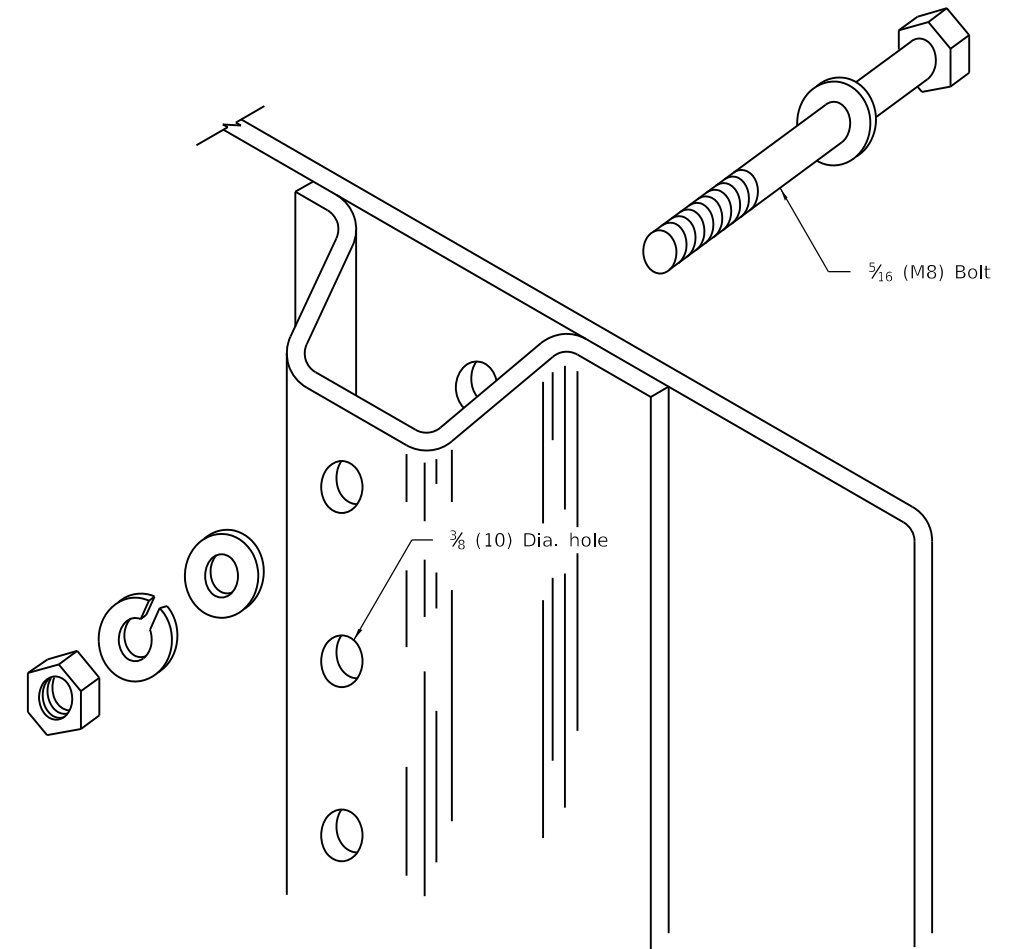

DETAIL OF MOUNTING SIGN TO POST

NOTE: Minimum of 2 bolts per post required.

GENERAL NOTES

DESIGN: Current AASHTO Standard Specifications for Structural Supports for Highway Signs, Luminaires and Traffic Signals.

LOADING: for 60 mph (95 km/h) wind velocity with 30% gust factor, normal to sign.

SOIL PRESSURE: Minimum allowable soil pressure 1.25 tsf (120 kPa).

See Standard 720011 for details of Types A and B posts.

All dimensions are in inches (millimeters) unless otherwise shown.

DATE	REVISIONS
1-1-09	Switched units to English (metric).
1-1-97	Renum. Standard 2363-2.

APPLICATIONS OF TYPES A & B METAL POSTS (FOR SIGNS & MARKERS)

STANDARD 729001-01

Illinois Department of Transportation

PASSED January 1, 2009

ENGINEER OF POLICY AND PROCEDURES

APPROVED January 1, 2009

ENGINEER OF DESIGN AND ENVIRONMENT

ISSUED 1-1-97