

STATE OF ILLINOIS
DEPARTMENT OF TRANSPORTATION

F.A. RTE.	SECTION	COUNTY	TOTAL SHEETS	SHEET NO.
VAR	2017-0311	VARIOUS	20	1
ILLINOIS			CONTRACT NO. 62F43	

FOR INDEX OF SHEETS, SEE SHEET NO. 2

PROPOSED HIGHWAY PLANS

ROUTE: VARIOUS EXPRESSWAYS AND ARTERIAL
HIGHWAYS – SOUTHERN PART, DISTRICT ONE

SECTION: 2017-0311

FENCE REPAIR

COUNTY: VARIOUS

C-91-296-17

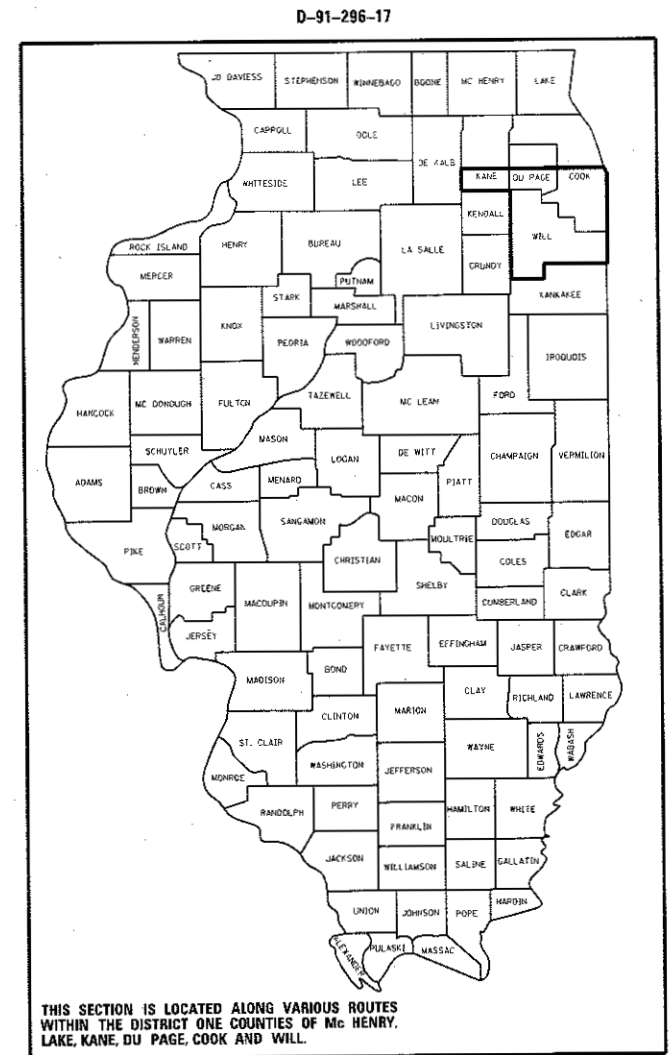

SEE LOCATION MAPS
SHEETS 4 THRU 12

C.U.A.N.
CHICAGO UTILITY ALERT NETWORK
1-312-744-7000

J.U.L.I.E.
JOINT UTILITY LOCATION INFORMATION FOR EXCAVATION
1-800-892-0123
OR 811

PROJECT ENGINEER: J. ALAIN MIDY (847) 221-3056
PROJECT MANAGER: ISSAM RAYYAN (847) 705-4178

CONTRACT NO. 62F43

STATE OF ILLINOIS
DEPARTMENT OF TRANSPORTATION

SUBMITTED JUNE 23 20 17

Anthony J. Quigley / *AS*
REGIONAL ENGINEER

David M. Adams / *DA*
ENGINEER OF DESIGN AND ENVIRONMENT

Paula A. [Signature] / *PA*
DIRECTOR OF PROGRAM DEVELOPMENT

PRINTED BY THE AUTHORITY
OF THE STATE OF ILLINOIS

INDEX OF SHEETS

1. TITLE SHEET
2. INDEX OF SHEETS
LIST OF APPLICABLE STATE STANDARDS
3. SUMMARY OF QUANTITIES
4. COOK COUNTY (SOUTH OF ILL 38) LOCATION MAP
5. DUPAGE COUNTY (SOUTH OF ILL 38) LOCATION MAP
6. KANE COUNTY (SOUTH OF ILL 38) LOCATION MAP
7. WILL COUNTY LOCATION MAP
8. COOK COUNTY (NORTH OF ILL 38) LOCATION MAP
9. DUPAGE COUNTY (NORTH OF ILL 38) LOCATION MAP
10. KANE COUNTY (NORTH OF ILL 38) LOCATION MAP
11. LAKE COUNTY LOCATION MAP
12. MCHENRY COUNTY LOCATION MAP
13. DETAILS OF PEDESTRIAN BARRIER TYPE III (STD. 10-SS-514R)
14. CHAIN LINK FENCE (STD. 10-SS-506B)
15. CHAIN LINK FENCE POST SLEEVE REPAIR DETAIL
16. PROPOSED PEDESTRIAN BARRIER AND CHAIN LINK FENCE
WITH TENSION WIRE AND FENCE RAIL REMOVAL
17. SPECIAL FENCE DETAILS
18. ENTRANCE AND EXIT RAMP CLOSURE DETAILS (TC-08)
19. TRAFFIC CONTROL AND PROTECTION FOR SIDE ROADS,
INTERSECTIONS AND DRIVEWAYS (TC-10)
20. TRAFFIC CONTROL DETAILS FOR SHOULDER CLOSURE AND
PARTIAL RAMP CLOSURES (TC-17)

GENERAL NOTES

1. BEFORE STARTING ANY EXCAVATION, THE CONTRACTOR SHALL CALL "J.U.L.I.E." AT (800) 892-0123 OR 811 FOR FIELD LOCATIONS OF BURIED ELECTRIC, TELEPHONE AND GAS UTILITIES. 48 HOUR NOTIFICATION IS REQUIRED.
2. THE CONTRACTOR SHALL CONTACT THE DISTRICT ONE TRAFFIC CONTROL SUPERVISOR AT (847) 705-4155 FOR EXPRESSWAYS AND (847) 705-4470 FOR ARTERIALS, A MINIMUM OF 72 HOURS IN ADVANCE OF BEGINNING WORK.

STATE STANDARDS

DESCRIPTION

664001-02	CHAIN LINK FENCE
665001-02	WOVEN WIRE FENCE
701001-02	OFF-RD OPERATIONS, 2L, 2W, MORE THAN 15' AWAY
701006-05	OFF-RD OPERATIONS, 2L, 2W, 15' TO 24" FROM PAVEMENT EDGE
701101-05	OFF-RD OPERATIONS, MULTILANE, 15' TO 24" FROM PAVEMENT EDGE
701106-02	OFF-RD OPERATIONS, MULTILANE, MORE THAN 15' AWAY
701301-04	LANE CLOSURE, 2L, 2W, SHORT TIME OPERATIONS
701311-03	LANE CLOSURE, 2L, 2W, MOVING OPERATIONS DAY ONLY
701336-06	LANE CLOSURE, 2L, 2W, WORK AREAS IN SERIES, FOR SPEEDS > 45 MPH
701400-09	APPROACH TO LANE CLOSURE, FREEWAY/EXPRESSWAY
701401-10	LANE CLOSURE, FREEWAY/EXPRESSWAY
701411-09	LANE CLOSURE, MULTILANE, AT ENTRANCE OR EXIT RAMP, FOR SPEEDS > 45 MPH
701421-08	LANE CLOSURE, MULTILANE, DAY OPERATIONS ONLY, FOR SPEEDS > 45 MPH TO 55 MPH
701422-09	LANE CLOSURE, MULTILANE, FOR SPEEDS > 45 MPH TO 55 MPH
701427-05	LANE CLOSURE, MULTILANE, INTERMITTANT OR MOVING OPERATIONS < 40 MPH
701501-06	URBAN LANE CLOSURE, 2L, 2W, UNDIVIDED
701601-09	URBAN LANE CLOSURE, MULTILANE, 1W OR 2W, WITH NONTRAVERSABLE MEDIAN
701602-08	URBAN LANE CLOSURE, MULTILANE, 2W WITH BIDIRECTIONAL LEFT TURN LANE
701606-10	URBAN LANE CLOSURE, MULTILANE, 2W WITH MOUNTABLE MEDIAN
701701-10	URBAN LANE CLOSURE, MULTILANE INTERSECTION
701801-06	SIDEWALK, CORNER OR CROSSWALK CLOSURE
701901-06	TRAFFIC CONTROL DEVICES

FILE NAME =	USER NAME = pyznowskarb	DESIGNED -	REVISED -	STATE OF ILLINOIS DEPARTMENT OF TRANSPORTATION	INDEX OF SHEETS AND STATE STANDARDS	F.A. RTE.	SECTION	COUNTY	TOTAL SHEETS	SHEET NO.	
Default		CHECKED -	REVISED -			VAR	2017-0311	VARIOUS	20	2	
	PLOT SCALE = 1/8" = 100.0000' / in.	DATE -	REVISED -			CONTRACT NO. 62F43					
	PLOT DATE = 6/28/2017					SCALE:	SHEET	OF	SHEETS	STA.	TO

URBAN

URBAN

SUMMARY OF QUANTITIES			CONSTRUCTION TYPE CODE 0021					
CODE NO	ITEM	UNIT	TOTAL QUANTITIES	100% STATE 0021	100% MCHD 0021			
66400505	CHAIN LINK FENCE, 8'	FOOT	237	187	50			
66500105	WOVEN WIRE FENCE, 4'	FOOT	5280	4224	1056			
X6640100	FENCE RAIL REMOVAL	FOOT	2200	1760	440			
X6640300	CHAIN LINK FENCE REMOVAL	FOOT	55	44	11			
X6640309	CHAIN LINK GATES (SPECIAL)	SO FT	770	616	154			
X6640590	CHAIN LINK FENCE POST SLEEVE REPAIR	EACH	44	35	9			
Z0009600	CHAIN LINK FABRIC, SPECIAL, 5'-0"	FOOT	22	18	4			
Z0009700	CHAIN LINK FABRIC, SPECIAL, 6'-0"	FOOT	1408	1162	246			
Z0009800	CHAIN LINK FABRIC, SPECIAL, 7'-0"	FOOT	9	7	2			
Z0009810	CHAIN LINK FABRIC, SPECIAL, 8'-0"	FOOT	66	53	13			
Z0009900	CHAIN LINK FABRIC, TYPE 1, 4'-0"	FOOT	18480	14784	3696			
Z0010300	CHAIN LINK FABRIC, TYPE 3, SPECIAL	FOOT	440	352	88			
Z0020210	PULL POST ARRANGEMENT	EACH	2	1	1			
Z0033200	LINE POST, TYPE 1	EACH	792	634	158			
Z0033305	LINE POST, TYPE 3 SPECIAL	EACH	22	18	4			
Z0042500	POST, SPECIAL	EACH	66	53	13			

SUMMARY OF QUANTITIES			CONSTRUCTION TYPE CODE 0021					
CODE NO	ITEM	UNIT	TOTAL QUANTITIES	100% STATE 0021	100% MCHD 0021			
Z0042505	POST REMOVAL AND REPLACEMENT	EACH	6	5	1			
Z0074000	TERMINAL POST, TYPE 1	EACH	44	35	9			
Z0074010	TERMINAL POST, TYPE 3 SPECIAL	EACH	6	5	1			

16

FILE NAME =	USER NAME = gyzanorshro	DESIGNED -	REVISED -	STATE OF ILLINOIS DEPARTMENT OF TRANSPORTATION	SUMMARY OF QUANTITIES			F.A. -	SECTION	COUNTY	TOTAL SHEETS	SHEET NO.	
DIR = \\VLD04E\BIC\TEC\I\roads\p\INDOT\Documents\DOT	DIR Files\District 1\Projects\1444516\CAD\Info\Design\1444516	CHECKED -	REVISED -					VAR	2017-0311	VARIOUS	20	3	
PLOT SCALE = 100,0000' / 1"		DATE -	REVISED -					SCALE: SHEET NO. OF SHEETS STA. TO STA.			FED. ROAD DIST. NO. 1 (ILLINOIS) FED. AID PROJECT		
PLOT DATE = 6/28/2017											CONTRACT NO. 62F43		

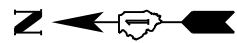

DISTRICT NO. 1 MAINTENANCE DESIGNATIONS

- VARIOUS COLORS STATE HIGHWAYS & EXPRESSWAYS
- TOLLWAY
- CITY MAINTENANCE AGREEMENTS
- - - - FUTURE HIGHWAYS
- VARIOUS AGENCIES HIGHWAYS

FILE NAME =	USER NAME = pyrzenowskirb	DESIGNED -	REVISED -
p:\1\084EBIDINTEG.111nois.gov\PIWIDOT\Documents\IDOT Offices\District 1\Projects\0144816\Design\0144816-sht-plan.dgn		DRWN -	REVISED -
Default	PLOT SCALE = 100.0000' / in.	CHECKED -	REVISED -
	PLOT DATE = 6/28/2017	DATE -	REVISED -

**STATE OF ILLINOIS
DEPARTMENT OF TRANSPORTATION**

**FENCE REPAIR LOCATION MAP - COOK COUNTY
SOUTH OF IL RTE 38**

SCALE: SHEET OF SHEETS STA. TO STA.

F.A. RTE.	SECTION	COUNTY	TOTAL SHEETS	SHEET NO.
VAR	2017-0311	VARIOUS	20	4
CONTRACT NO. 62F43				
ILLINOIS FED. AID PROJECT				

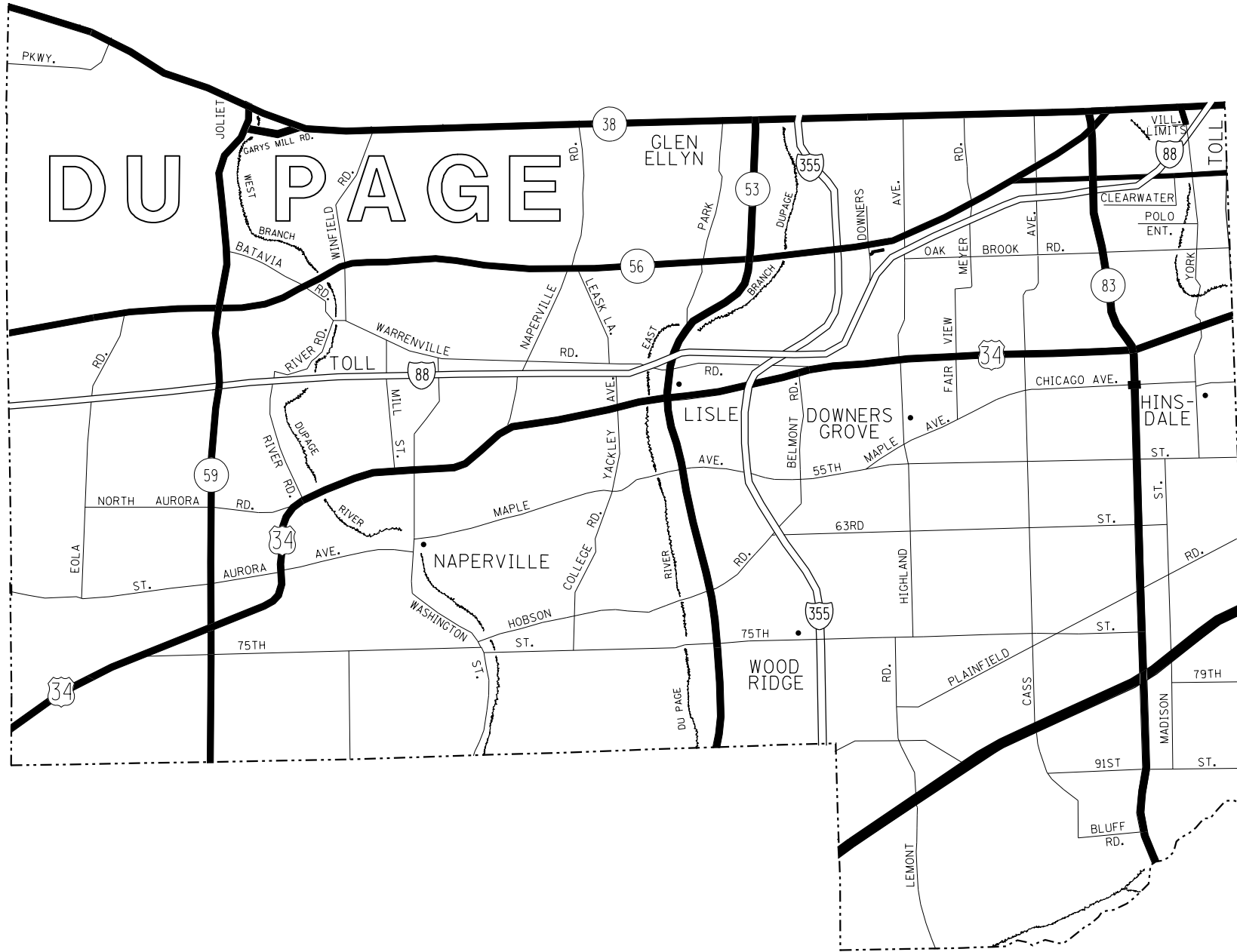

DISTRICT NO. 1
MAINTENANCE DESIGNATIONS

- VARIOUS COLORS STATE HIGHWAYS & EXPRESSWAYS
- TOLLWAY
- ▬ CITY MAINTENANCE AGREEMENTS
- - - FUTURE HIGHWAYS
- VARIOUS AGENCIES HIGHWAYS

FILE NAME =	USER NAME = pyrzenowski	DESIGNED -	REVISED -
pw\l\084EBIDINTEG.illinois.gov\PIDOT\Documents\IDOT Offices\District 1\Projects\144816\Design\144816-shr-plan.dgn		REVISED -	REVISED -
Default		CHECKED -	REVISED -
	PLOT DATE = 6/28/2017	DATE -	REVISED -

STATE OF ILLINOIS
DEPARTMENT OF TRANSPORTATION

FENCE REPAIR LOCATION MAP - DuPAGE COUNTY
SOUTH OF IL RTE 38

SCALE: SHEET OF SHEETS STA. TO STA.

F.A. RTE.	SECTION	COUNTY	TOTAL SHEETS	SHEET NO.
VAR	2017-0311	VARIOUS	20	5
CONTRACT NO. 62F43				
ILLINOIS FED. AID PROJECT				

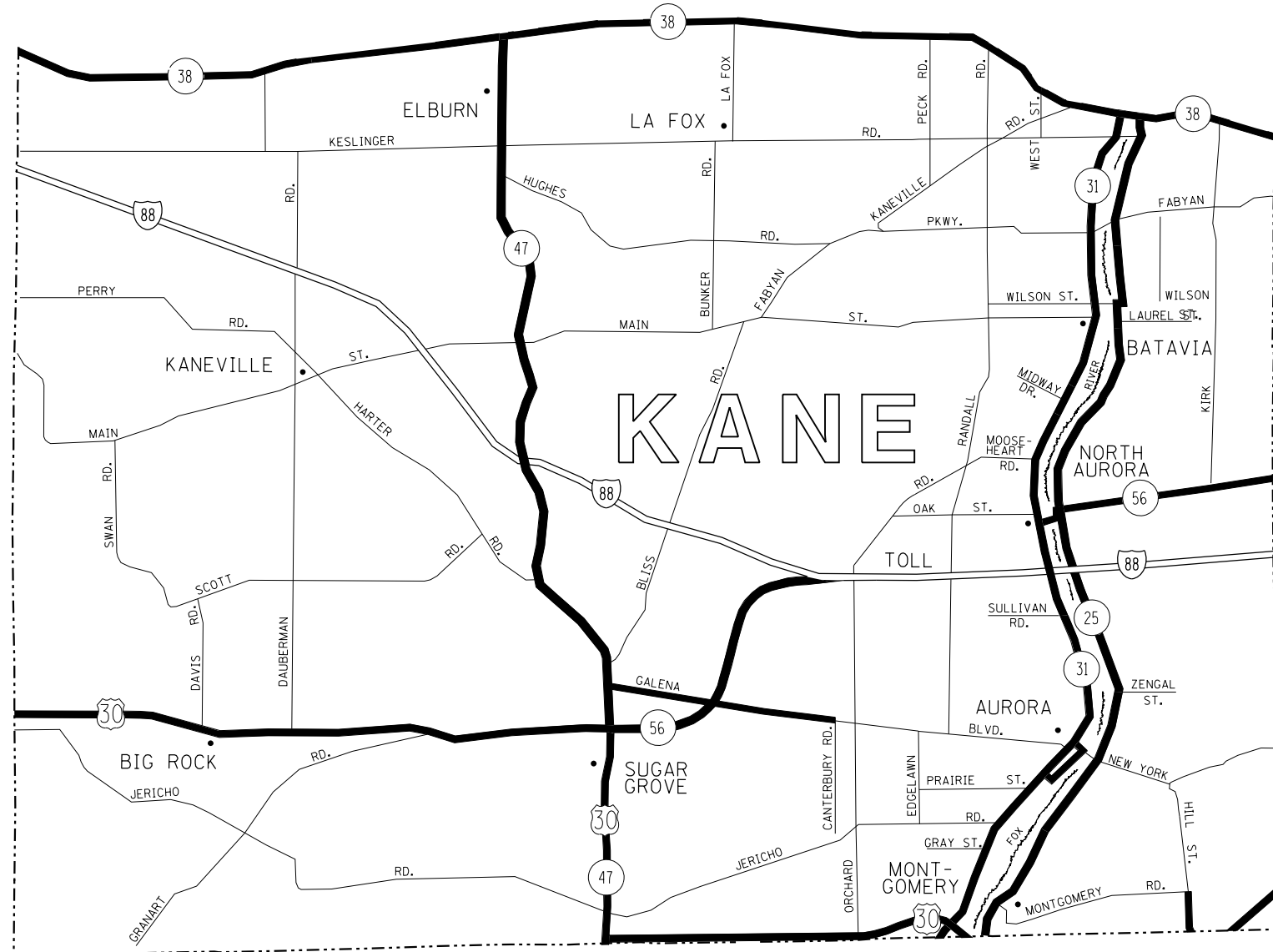

DISTRICT NO. 1
MAINTENANCE DESIGNATIONS

- VARIOUS COLORS STATE HIGHWAYS & EXPRESSWAYS
- ===== TOLLWAY
- █ CITY MAINTENANCE AGREEMENTS
- FUTURE HIGHWAYS
- VARIOUS AGENCIES HIGHWAYS

FILE NAME =	USER NAME = pyrzenowskirb	DESIGNED -	REVISED -
p:\IL\084EBIDINTEG\illinois.gov\PIDOT\Documents\IDOT Offices\District 1\Projects\D144816\Drawings\Design\144816-sh-t-plan.dgn		CHECKED -	REVISED -
Default	PLOT DATE = 6/28/2017	DATE -	REVISED -

STATE OF ILLINOIS
DEPARTMENT OF TRANSPORTATION

FENCE REPAIR LOCATION MAP - KANE COUNTY
SOUTH OF IL RTE 38

SCALE: SHEET OF SHEETS STA. TO STA.

F.A. RTE.	SECTION	COUNTY	TOTAL SHEETS	SHEET NO.
VAR	2017-0311	VARIOUS	20	6
			CONTRACT NO. 62F43	
ILLINOIS FED. AID PROJECT				

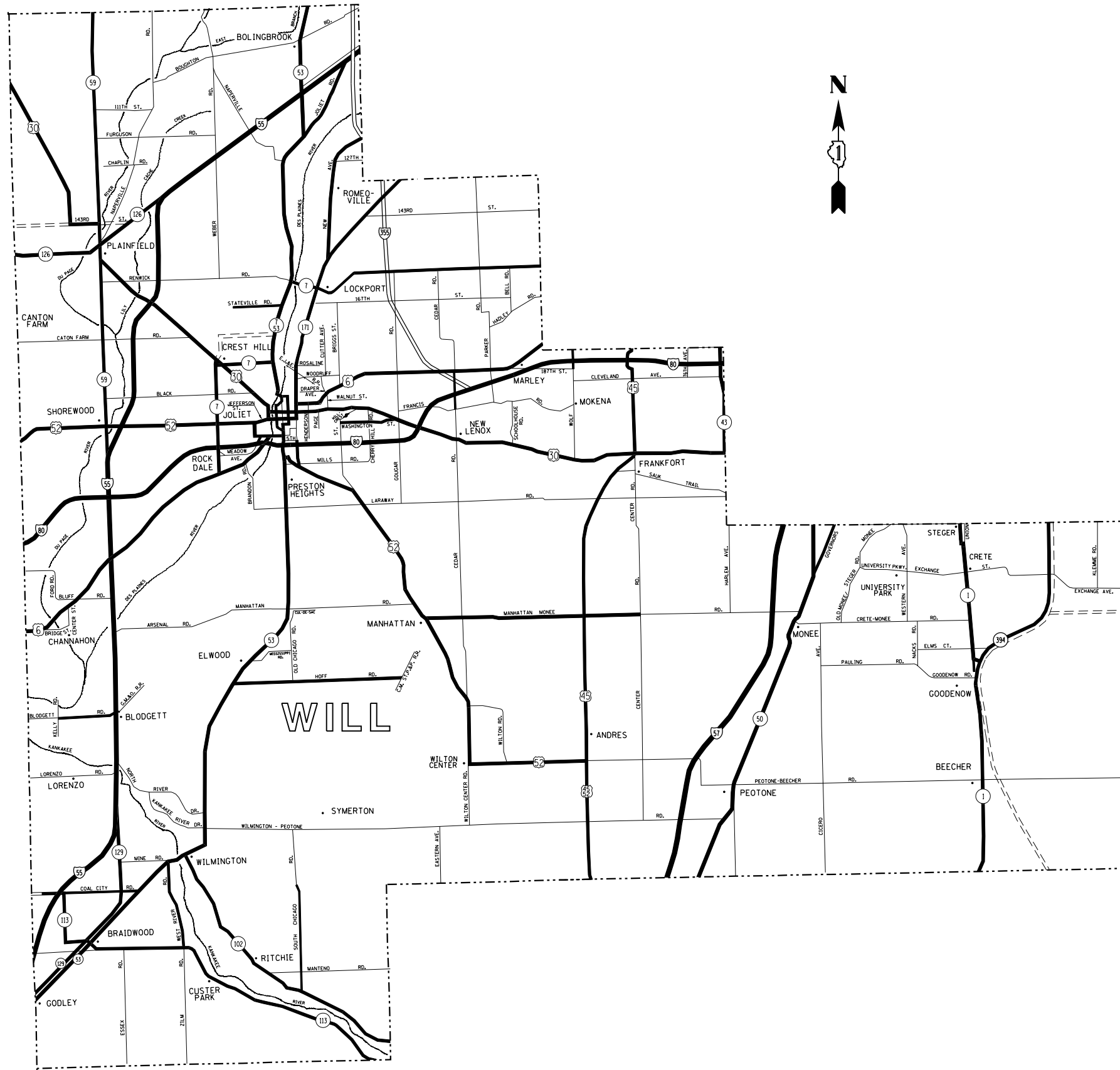

DISTRICT NO. 1 MAINTENANCE DESIGNATIONS

- VARIOUS COLORS STATE HIGHWAYS & EXPRESSWAYS
- TOLLWAY
- CITY MAINTENANCE AGREEMENTS
- FUTURE HIGHWAYS
- VARIOUS AGENCIES HIGHWAYS

FILE NAME =	USER NAME = pyznowskirb	DESIGNED -	REVISED -
pw\11084EBIDINTEG\illinois.gov\PIWIDOT\Documents\DOT Offices\District 1\Projects\144816\Design\144816-sht-plan.dgn		DRWN	REVISED -
Default	PLOT SCALE = 100.0000' / in.	CHECKED -	REVISED -
	PLOT DATE = 6/28/2017	DATE -	REVISED -

**STATE OF ILLINOIS
DEPARTMENT OF TRANSPORTATION**

FENCE REPAIR LOCATION MAP – WILL COUNTY

SCALE: SHEET OF SHEETS STA. TO STA.

F.A. RTE.	SECTION	COUNTY	TOTAL SHEETS	SHEET NO.
VAR	2017-0311	VARIOUS	20	7
CONTRACT NO. 62F43				
ILLINOIS FED. AID PROJECT				

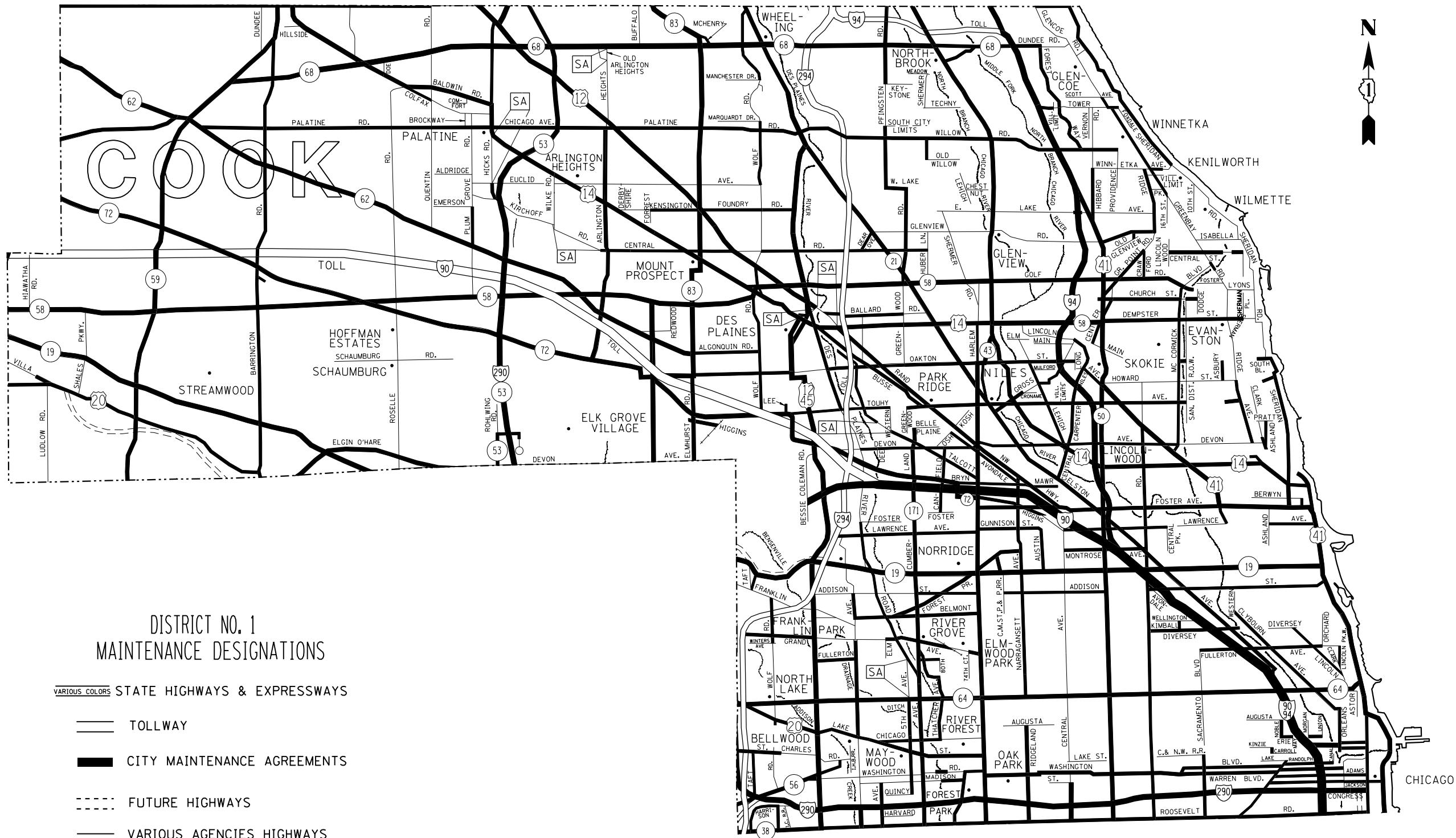

DISTRICT NO. 1
MAINTENANCE DESIGNATIONS

- VARIOUS COLORS STATE HIGHWAYS & EXPRESSWAYS
- TOLLWAY
 - CITY MAINTENANCE AGREEMENTS
 - FUTURE HIGHWAYS
 - VARIOUS AGENCIES HIGHWAYS

FILE NAME =	USER NAME = pyrzenowski	DESIGNED -	REVISED -
p:\11084EBIDINTEG\11nois.gov\PIWIDOT\Documents\IDOT Offices\District 1\Projects\144816\144816-sht-plan.dgn		REVISED -	REVISED -
Default	PLOT SCALE = 100.0000' / in.	CHECKED -	REVISED -
	DATE = 6/28/2017	DATE -	REVISED -

STATE OF ILLINOIS
DEPARTMENT OF TRANSPORTATION

FENCE REPAIR LOCATION MAP - COOK COUNTY			
SOUTH OF IL RTE 38			
SCALE:	SHEET	OF SHEETS	STA. TO STA.

F.A. RTE.	SECTION	COUNTY	TOTAL SHEETS	SHEET NO.
VAR	2017-0311	VARIOUS	20	8
CONTRACT NO. 62F43				
ILLINOIS FED. AID PROJECT				

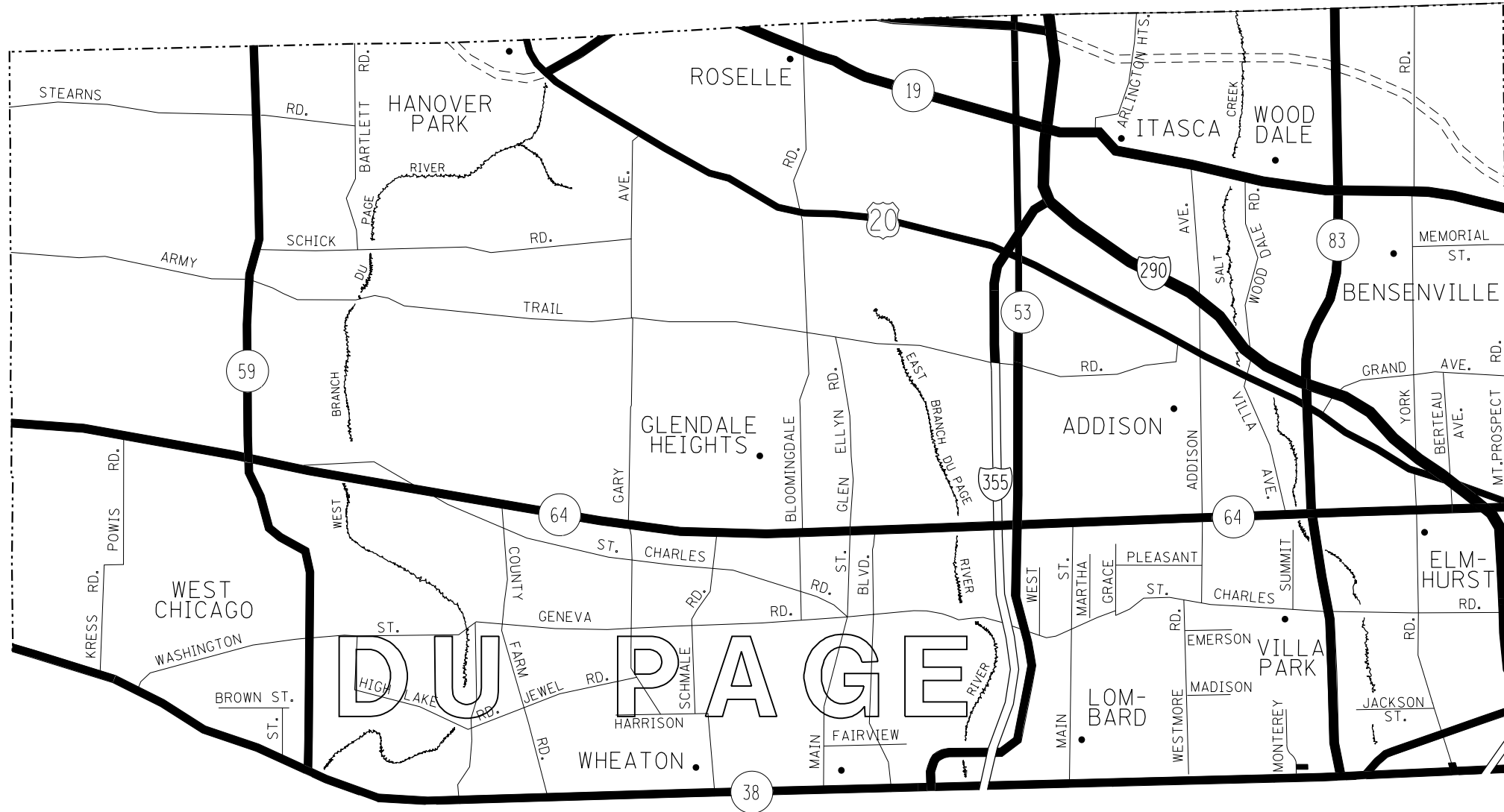

DISTRICT NO. 1
MAINTENANCE DESIGNATIONS

- VARIOUS COLORS STATE HIGHWAYS & EXPRESSWAYS
- TOLLWAY
- CITY MAINTENANCE AGREEMENTS
- FUTURE HIGHWAYS
- VARIOUS AGENCIES HIGHWAYS

FILE NAME =	USER NAME = pyrzezowski	DESIGNED -	REVISED -	STATE OF ILLINOIS DEPARTMENT OF TRANSPORTATION	FENCE REPAIR LOCATION MAP - DuPAGE COUNTY SOUTH OF IL RTE 38	F.A. RTE.	SECTION	COUNTY	TOTAL SHEETS	SHEET NO.
		CHECKED -	REVISED -			VAR	2017-0311	VARIOUS	20	9
		DATE -	REVISED -			CONTRACT NO. 62F43				
					SCALE:	SHEET OF SHEETS		STA. TO STA.		ILLINOIS FED. AID PROJECT

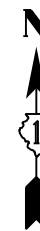
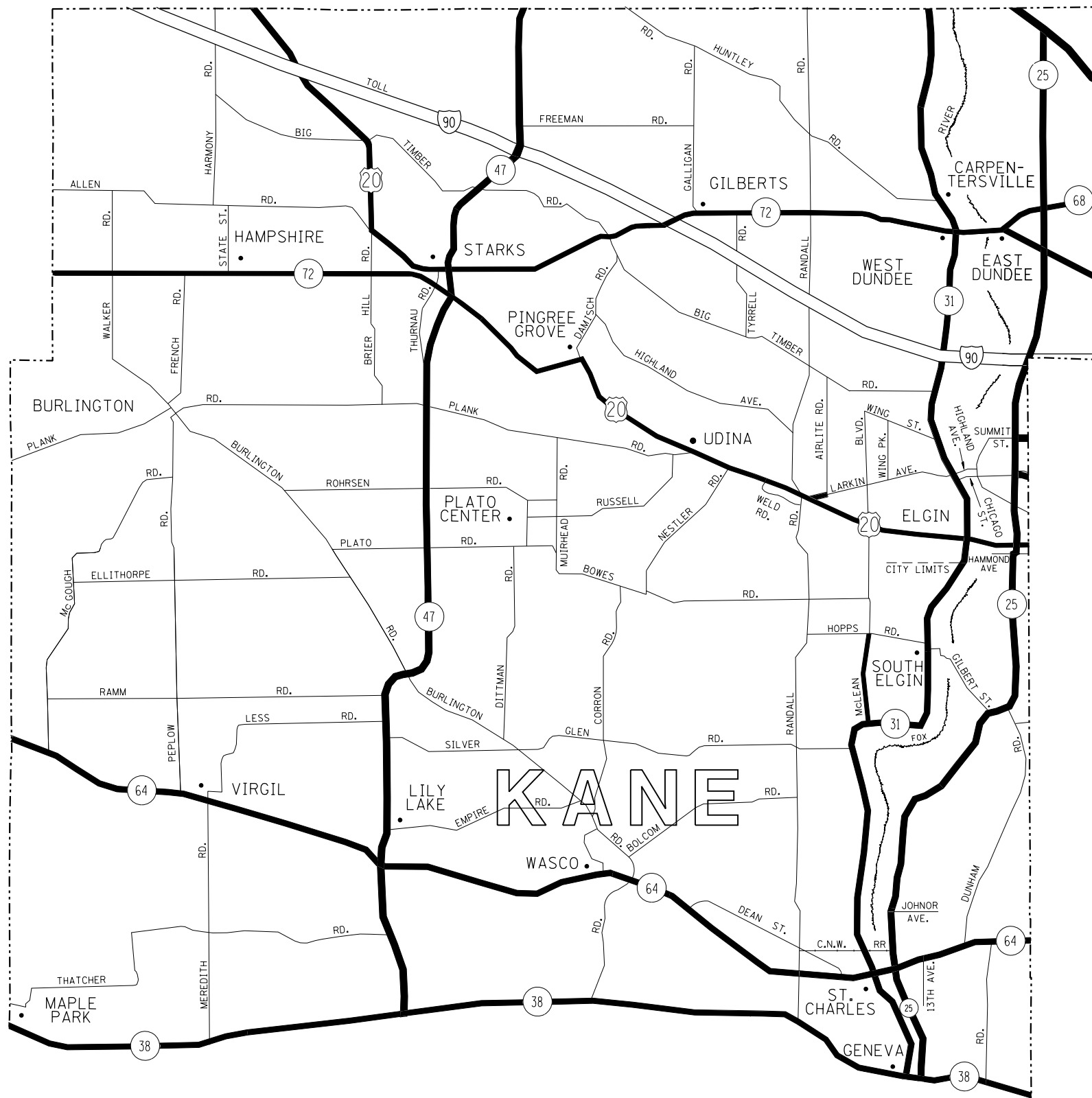

DISTRICT NO. 1
MAINTENANCE DESIGNATIONS

- VARIOUS COLORS STATE HIGHWAYS & EXPRESSWAYS
- TOLLWAY
- CITY MAINTENANCE AGREEMENTS
- FUTURE HIGHWAYS
- VARIOUS AGENCIES HIGHWAYS

FILE NAME =	USER NAME = pyzzenowskirb	DESIGNED -	REVISED -
p:\1\084EBIDINTEG.illinois.gov\PIWIDOT\Documents\DOT Offices\District 1\Projects\144816\Design\144816-shr-plan.dgn		DRWN	REVISED -
Default	PLOT SCALE = 100.0000' / in.	CHECKED -	REVISED -
	PLOT DATE = 6/28/2017	DATE -	REVISED -

STATE OF ILLINOIS
DEPARTMENT OF TRANSPORTATION

FENCE REPAIR LOCATION MAP - KANE COUNTY
SOUTH OF IL RTE 38

SCALE: SHEET OF SHEETS STA. TO STA.

F.A. RTE.	SECTION	COUNTY	TOTAL SHEETS	SHEET NO.
VAR	2017-0311	VARIOUS	20	10
CONTRACT NO. 62F43				
ILLINOIS FED. AID PROJECT				

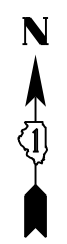
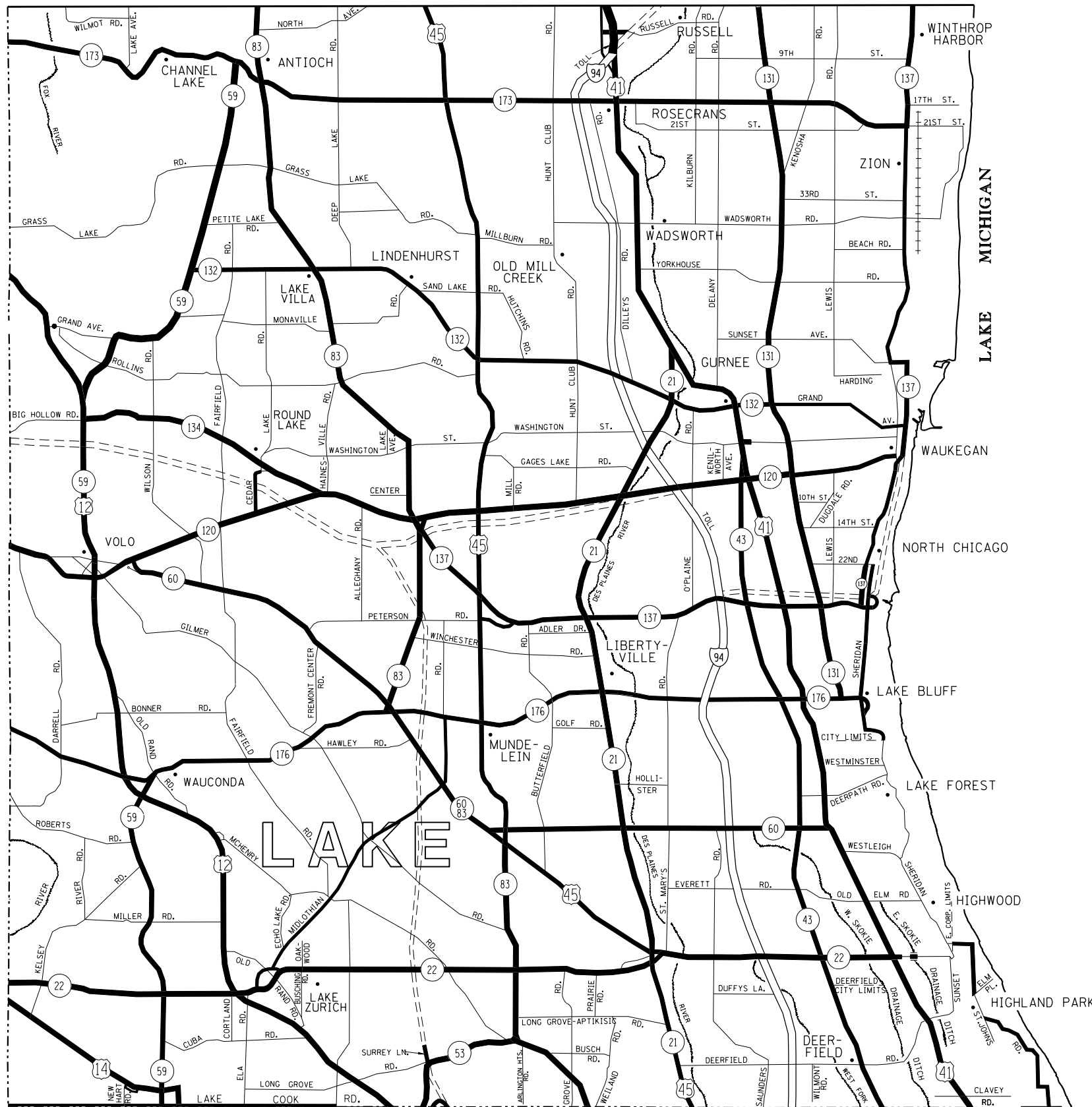

DISTRICT NO. 1 MAINTENANCE DESIGNATIONS

- VARIOUS COLORS STATE HIGHWAYS & EXPRESSWAYS
- TOLLWAY
- CITY MAINTENANCE AGREEMENTS
- FUTURE HIGHWAYS
- VARIOUS AGENCIES HIGHWAYS

FILE NAME =	USER NAME = pyznowskirb	DESIGNED -	REVISED -	STATE OF ILLINOIS DEPARTMENT OF TRANSPORTATION	FENCE REPAIR LOCATION MAP - WILL COUNTY	F.A. RTE.	SECTION	COUNTY	TOTAL SHEETS	SHEET NO.	
						VAR	2017-0311	VARIOUS	20	11	
						CONTRACT NO. 62F43					
Default	PLOT SCALE = 100.0000' / in.	CHECKED -	REVISED -			ILLINOIS FED. AID PROJECT					
	PLOT DATE = 6/28/2017	DATE -	REVISED -	SCALE:	SHEET	OF	SHEETS	STA.	TO	STA.	

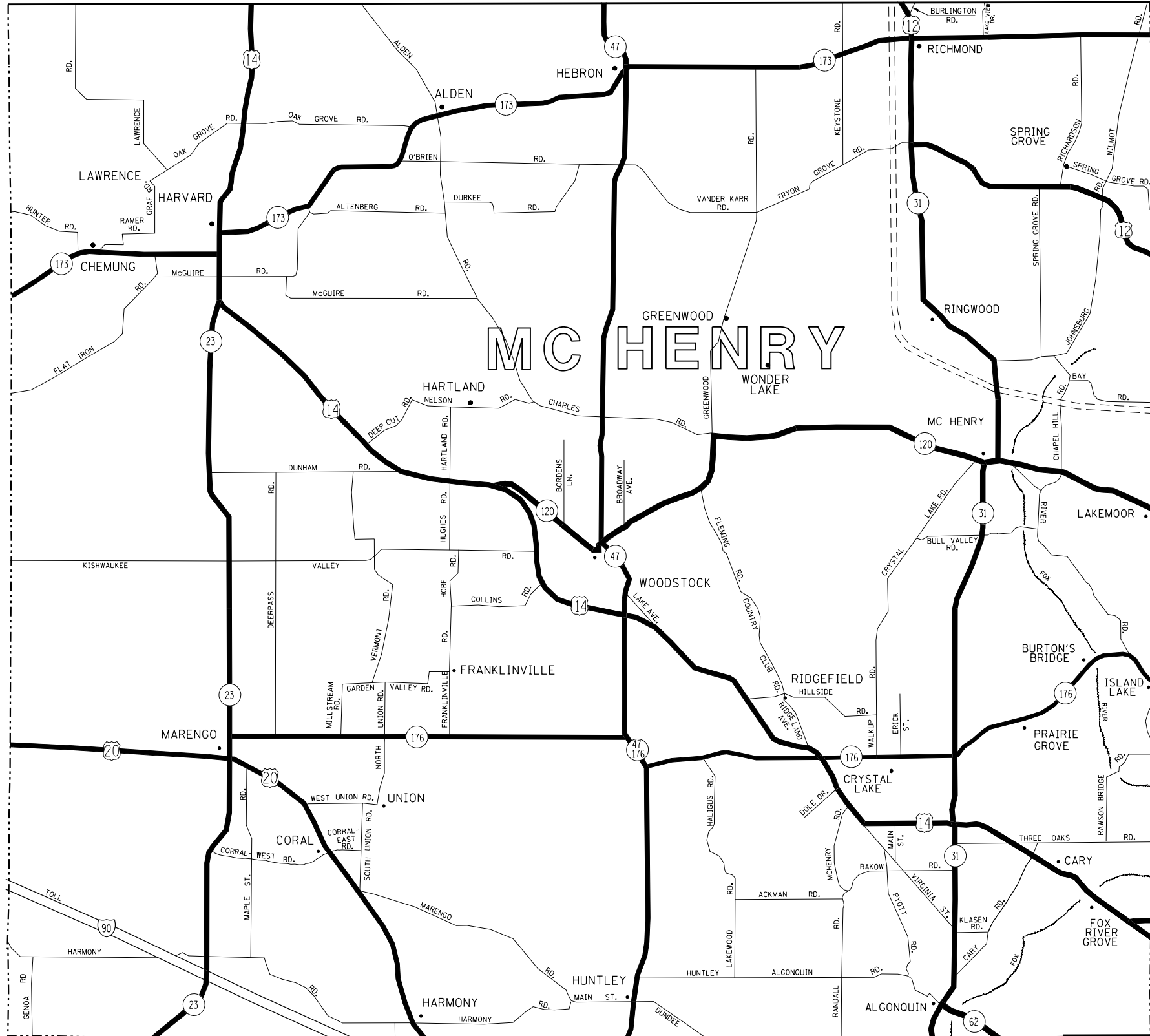

DISTRICT NO. 1 MAINTENANCE DESIGNATIONS

- VARIOUS COLORS STATE HIGHWAYS & EXPRESSWAYS
- TOLLWAY
- CITY MAINTENANCE AGREEMENTS
- - - FUTURE HIGHWAYS
- VARIOUS AGENCIES HIGHWAYS

FILE NAME =	USER NAME = pyznowskirb	DESIGNED -	REVISED -	STATE OF ILLINOIS DEPARTMENT OF TRANSPORTATION	SCALE:	SHEET NO.	OF	SHEETS	STA.	TO STA.	F.A. RTE.	SECTION	COUNTY	TOTAL SHEETS	SHEET NO.							
pw:\11\084EBID\INTEG\illinois.gov\PIWIDOT\Documents\IDOT Offices\District 1\Projects\144816\144816-sht-plan.dgn											VAR.	2017-0311	VARIOUS	20	12							
PLOT SCALE = 100.0000' / in.											CONTRACT NO. 62F43											
PLOT DATE = 6/28/2017											FED. ROAD DIST. NO. ILLINOIS FED. AID PROJECT											

NOTE

* MAXIMUM POST SPACING SHALL BE 3 m (10') C&C EXCEPT WHERE OTHERWISE SHOWN ON PLANS

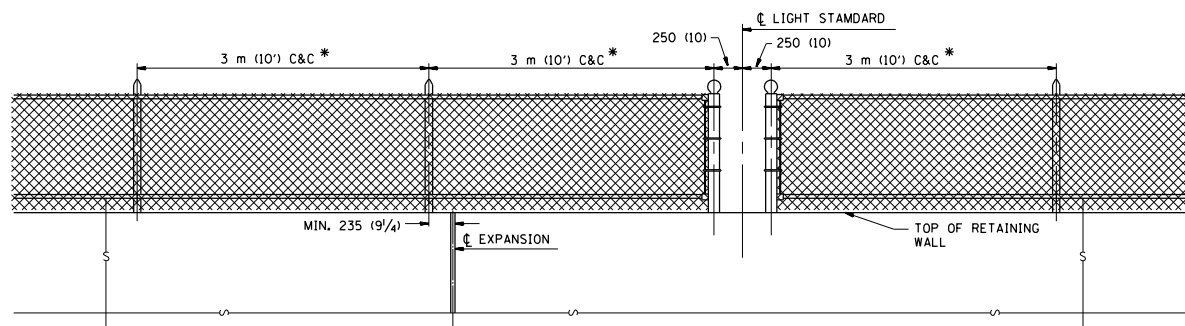

ELEVATION VIEW OF RETAINING WALL WITH PEDESTRIAN BARRIER TYPE III

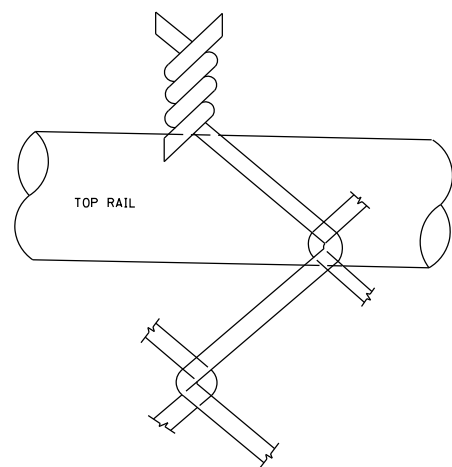

WIRE MESH FABRIC TO BE BARBED AT THE TOP

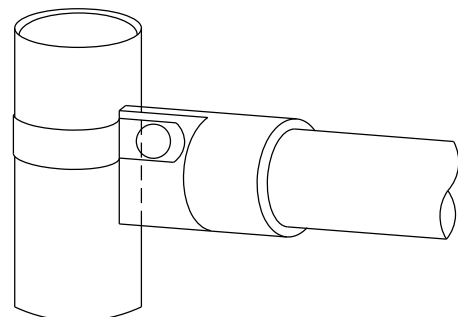

RAIL FITTING AT END POSTS

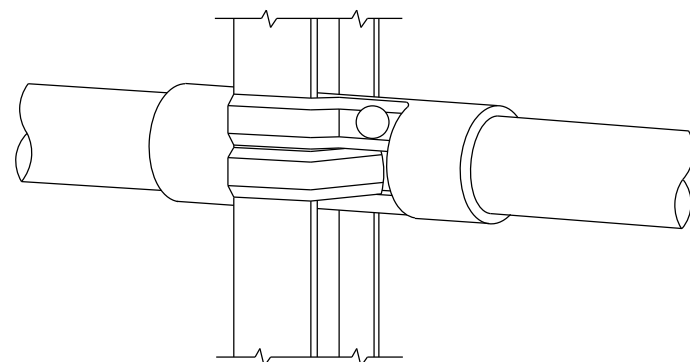

RAIL FITTING ON SECTION LINE POST

FOR INFORMATIONAL PURPOSES ONLY

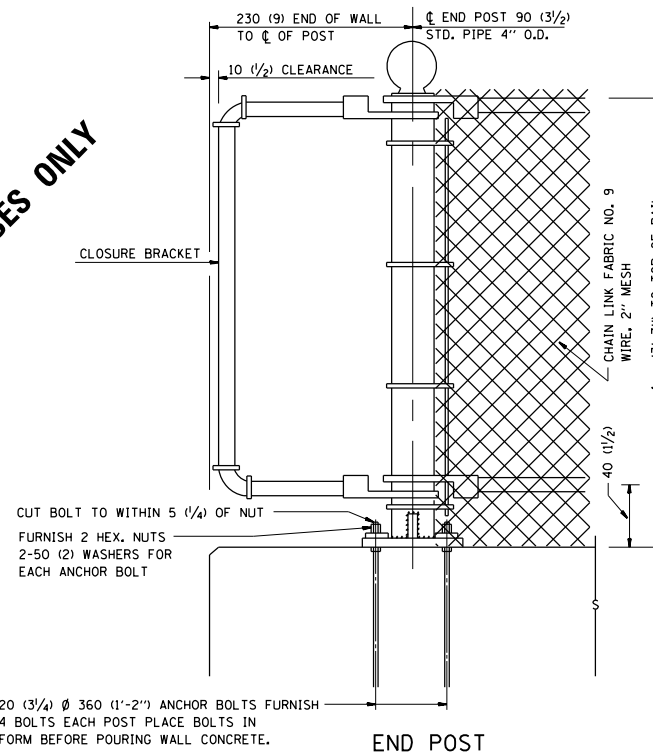

END POST

NOTE:
THE COST OF FURNISHING ANCHOR BOLTS, NUTS, & WASHERS TO BE INCIDENTAL

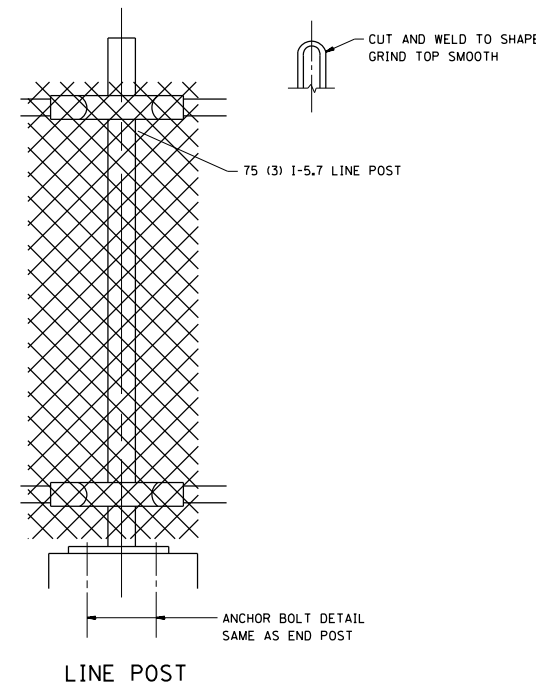

LINE POST

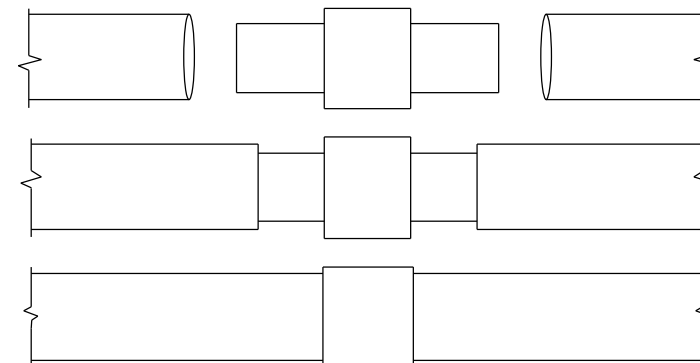

EXPANSION COUPLING DETAIL

NOTE:
EXP. COUPLING TO APPEAR IN TOP AND BOTTOM RAILS WHERE EVER EXP. JT. APPEARS IN STRUCTURE.

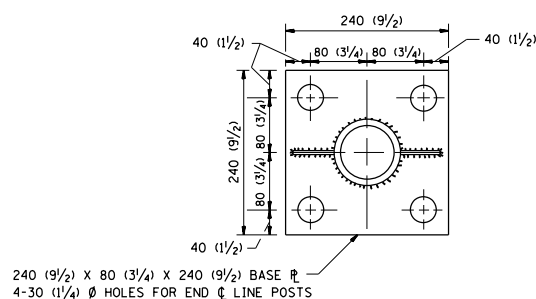

ANCHOR PLATE DETAILS

NOTE:
POST, PLATE AND GUSSET ASSEMBLY SHALL BE GALVANIZED AFTER ALL CUTTING, DRILLING, WELDING, AND FABRICATION HAVE BEEN COMPLETED. THE GALVANIZED COATING SHALL CONFORM TO THE REQUIREMENTS OF AASHTO M 120. THE GALVANIZED COATING SHALL NOT BE LESS THAN 610 G/SQ M (2.0 OZ./SQ. FT.) OF SURFACE.

ALL DIMENSIONS ARE IN MILLIMETERS (INCHES) UNLESS OTHERWISE SHOWN.

FILE NAME =	USER NAME = pyrzenowski	DESIGNED -	REVISED -	STATE OF ILLINOIS DEPARTMENT OF TRANSPORTATION	PEDESTRIAN BARRIER TYPE III STD. 10-SS-514 R				F.A. RTÉ.	SECTION	COUNTY	TOTAL SHEETS	SHEET NO.
pw:\IL\084EBIDINTEG\illinois.gov\PWIDOT\Documents\DOT Offices\District 1\Projects\1448\Design\144816-shr-plan.dgn	PLOT SCALE = 100.0000' / 1in.	CHECKED -	REVISED -						VAR	2017-0311	VARIOUS	20	13
PLOT DATE = 6/28/2017	DATE -	REVISED -	REVISED -		CONTRACT NO. 62F43				FED. ROAD DIST. NO.	ILLINOIS FED. AID PROJECT			
					SCALE:	SHEET NO.	OF SHEETS	STA.	TO STA.				

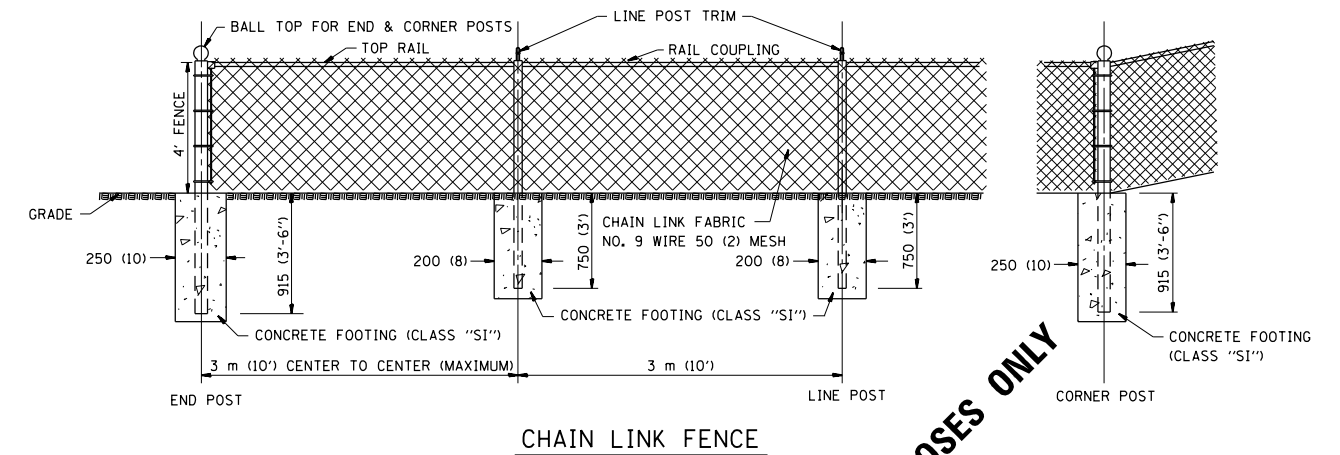

CHAIN LINK FENCE

FOR INFORMATIONAL PURPOSES ONLY

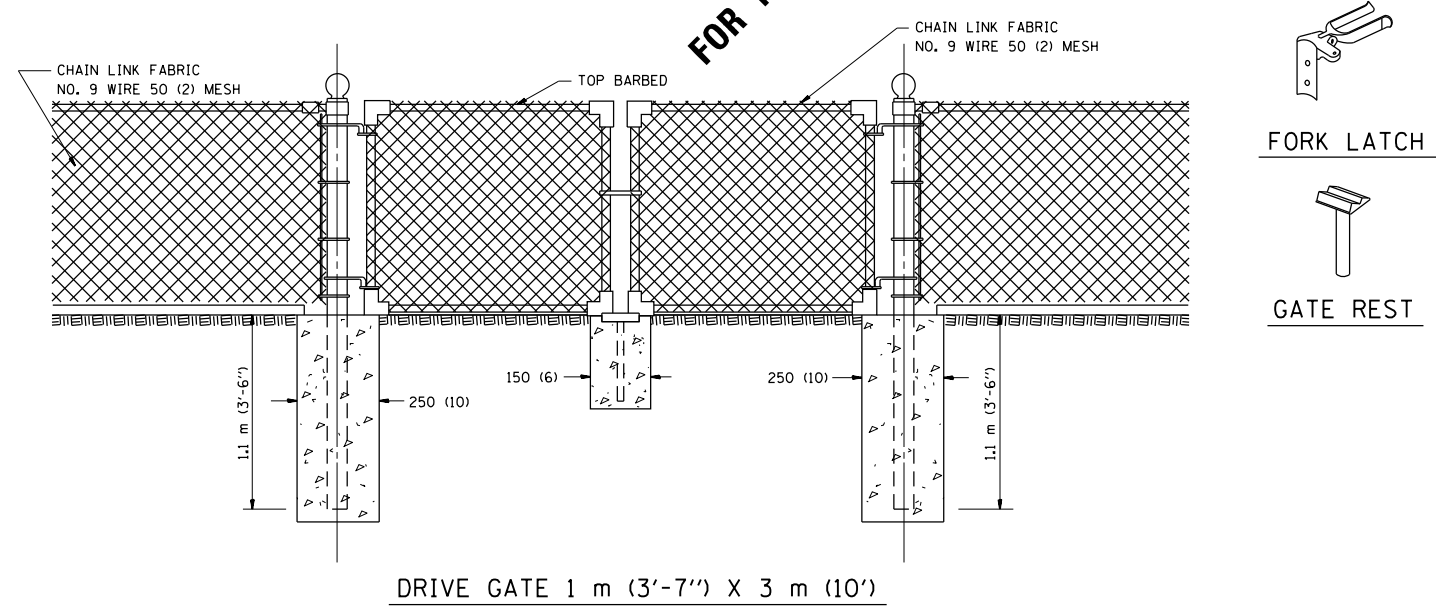

DRIVE GATE 1 m (3'-7") X 3 m (10')

ALL DIMENSIONS ARE IN MILLIMETERS (INCHES) UNLESS OTHERWISE SHOWN.

NOTE:
 THE CHAIN LINK FENCE AS SHOWN HEREIN SHALL BE CONSTRUCTED AT SUCH LOCATIONS AS SHOWN ON PLANS AND IN ACCORDANCE WITH THE SPECIAL PROVISIONS
 THE ENGINEER SHALL ESTABLISH ALL NECESSARY LINE AND GRADE PRIOR TO THE ERECTION OF THE FENCE IN CONFORMANCE WITH THE PLANS

FILE NAME =	USER NAME = pyzenowski	DESIGNED -	REVISED -
p:\11084EBIDINTEG\illinois.gov\PWIDOT\Documents\IDOT Offices\District 1\Projects\14486\14486-sht-plan.dgn		CHECKED -	REVISED -
		DATE -	REVISED -

STATE OF ILLINOIS
 DEPARTMENT OF TRANSPORTATION

CHAIN LINK FENCE
 STD. 10-SS-506 B

SCALE:	SHEET NO.	OF SHEETS	STA.	TO STA.
--------	-----------	-----------	------	---------

F.A. RTE.	SECTION	COUNTY	TOTAL SHEETS	SHEET NO.
VAR	2017-0311	VARIOUS	20	14
CONTRACT NO. 62F43				
FED. ROAD DIST. NO. ILLINOIS FED. AID PROJECT				

GENERAL NOTES:

THIS WORK CONSISTS OF FURNISHING ALL LABOR, MATERIALS, TOOLS AND EQUIPMENT TO REPAIR CHAIN LINK FENCE POST SLEEVE AS SHOWN ON THE PLANS OR AS DIRECTED BY THE ENGINEER, AND IN ACCORDANCE WITH STATE STANDARD 664001.

BASIS OF PAVEMENT: THIS WORK SHALL BE PAID FOR AT THE CONTRACT UNIT PRICE EACH FOR "CHAIN LINK FENCE POST SLEEVE REPAIR" WHICH PRICE SHALL BE PAYMENT IN FULL TO COMPLETE THE WORK AS SPECIFIED HEREIN.

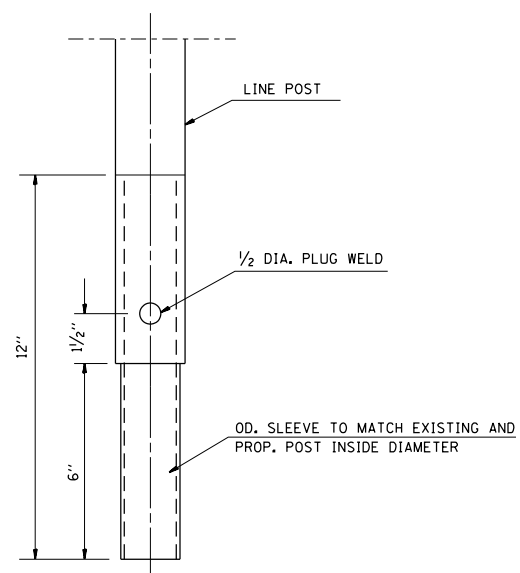
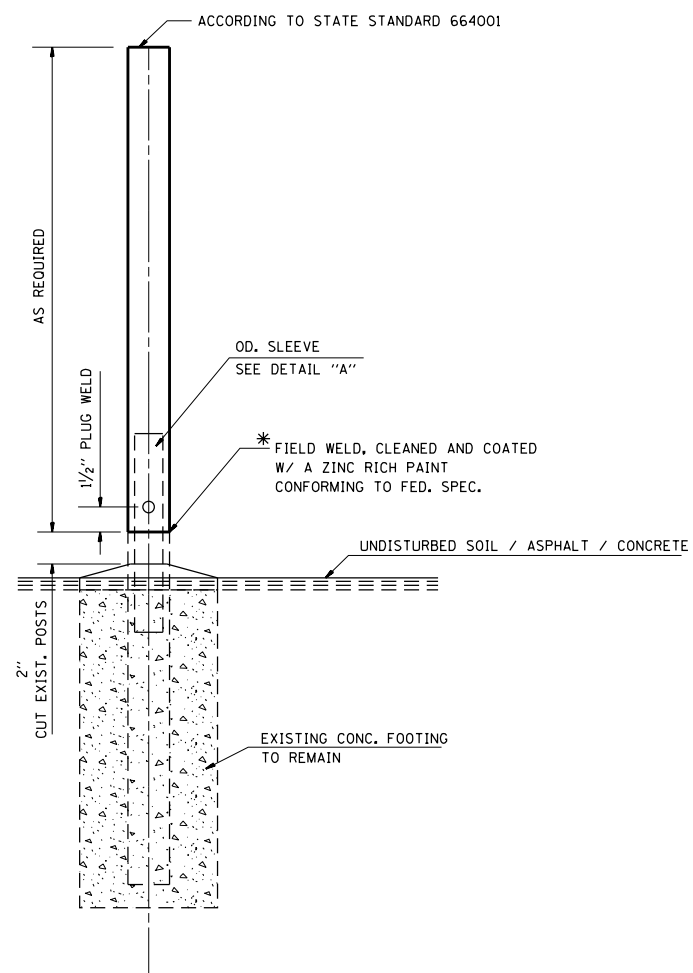

SLEEVE DET. DWG

DETAIL "A"
SLEEVE DETAIL

* THIS WORK SHALL BE INCLUDED IN THE COST OF THE PAY ITEM "CHAIN LINK FENCE POST SLEEVE REPAIR"

FILE NAME =	USER NAME = pyzzenowskirb	DESIGNED -	REVISED -
p:\11\084EBIDINTEG.illinois.gov\PIWIDOT\Documents\IDOT Offices\District 1\Projects\144816\144816.dwg		CHECKED -	REVISED -
		DATE -	REVISED -

**STATE OF ILLINOIS
DEPARTMENT OF TRANSPORTATION**

**CHAIN LINK FENCE POST SLEEVE
REPAIR DETAIL**

SCALE: SHEET NO. OF SHEETS STA. TO STA.

F.A. RTE.	SECTION	COUNTY	TOTAL SHEETS	SHEET NO.
VAR	2017-0311	VARIOUS	20	15
CONTRACT NO. 62F43				
FED. ROAD DIST. NO. ILLINOIS FED. AID PROJECT				

GENERAL NOTES

FENCE RAIL REMOVAL: THIS ITEM CONSISTS OF REMOVING EXISTING TOP OR BOTTOM RAIL, (DAMAGED OR UNDAMAGED) AND REPLACING WITH TENSION WIRE. BOTTOM TENSION WIRE SHALL BE CONSIDERED INCIDENTAL EXCEPT AT LOCATIONS OF EXISTING BOTTOM RAIL REMOVAL.

TENSION WIRE: THIS ITEM CONSISTS OF INSTALLING TENSION WIRE, TOP OR BOTTOM, WHERE TOP OR BOTTOM RAIL IS NON-EXISTENT, OR WHERE EXISTING DAMAGED TENSION WIRE IS REMOVED AND REPLACED BY NEW TENSION WIRE.

ALL WORK AND MATERIALS SHALL BE IN ACCORDANCE WITH THE PLANS, SPECIAL PROVISIONS, STANDARD SPECIFICATIONS AND STANDARD 664001.

REPLACEMENT OF OTHER FENCE COMPONENT PARTS SHALL BE MEASURED AND PAID FOR SEPARATELY AS DESCRIBED IN THE SPECIAL PROVISIONS.

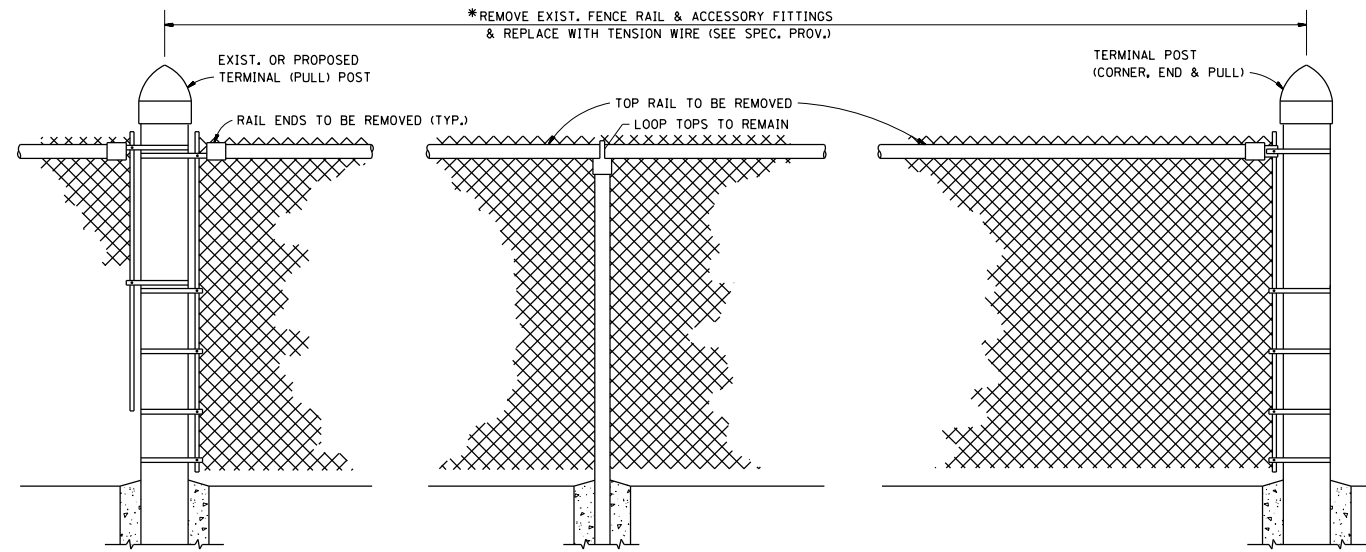

EXIST. CHAIN LINK FENCE WITH TOP RAIL

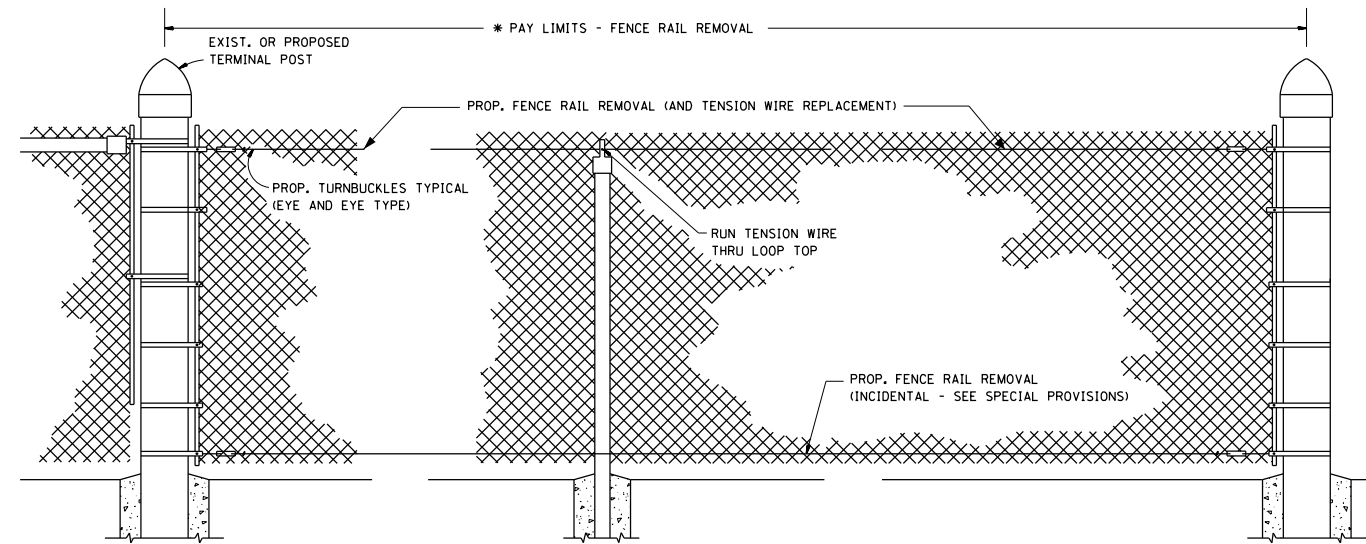

PROP. CHAIN LINK FENCE WITH "FENCE RAIL REMOVAL"

* THE ENGINEER IN CHARGE SHALL DETERMINE THE LENGTH OF FENCE RAIL TO BE REMOVED & REPLACED WITH "TENSION WIRE"

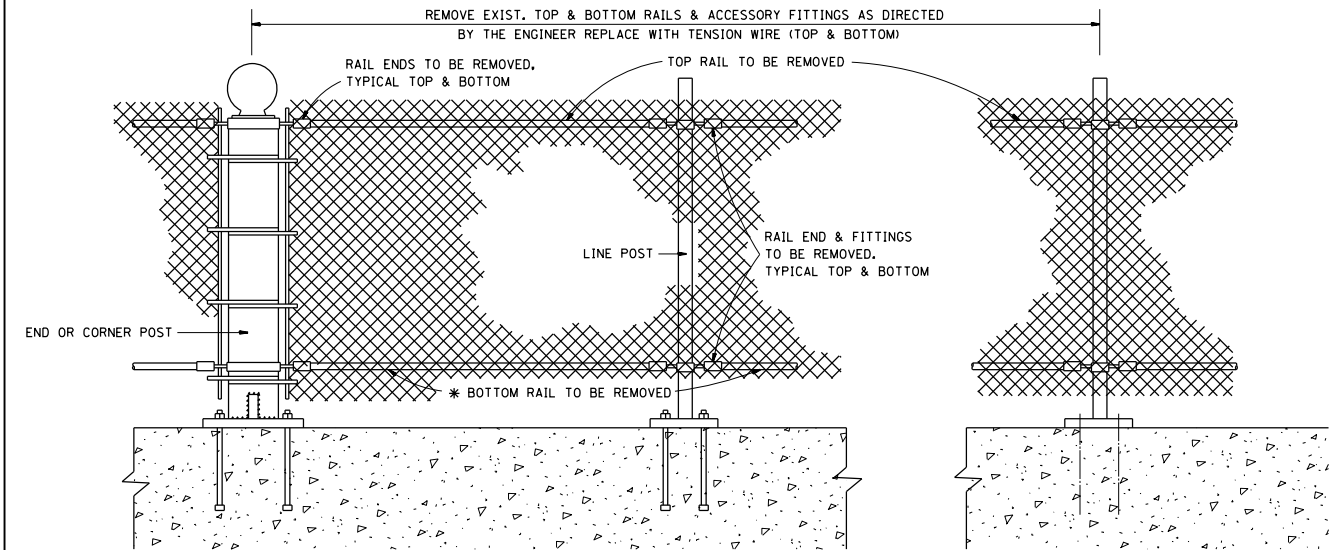

EXIST. PEDESTRIAN BARRIER TYPE 3 WITH TOP AND BOTTOM RAILS

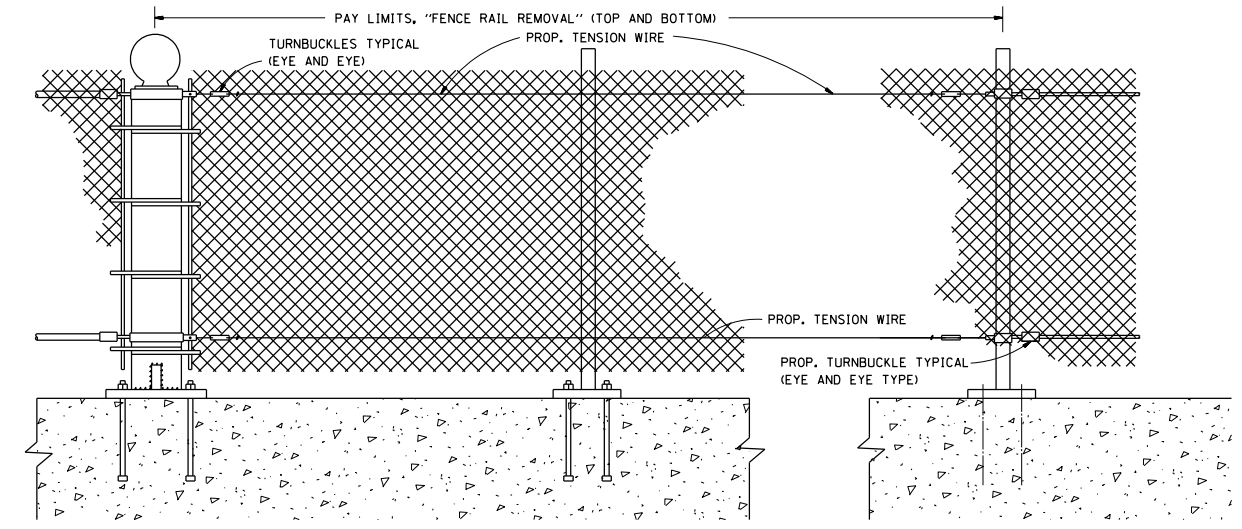

PROP. PEDESTRIAN BARRIER TYPE 3 WITH FENCE RAIL REMOVAL

ALL DIMENSIONS ARE IN MILLIMETERS (INCHES) UNLESS OTHERWISE SHOWN.

FILE NAME =	USER NAME = pyrzenowski	DESIGNED -	REVISED -
p:\11\084EBIDINTEG.illinois.gov\PIWIDOT\Documents\DOT Offices\District 1\Projects\144816\Design\144816-shr-plan.dgn		CHECKED -	REVISED -
		DATE -	REVISED -

**STATE OF ILLINOIS
DEPARTMENT OF TRANSPORTATION**

**PROPOSED PEDESTRIAN BARRIER AND
CHAIN LINK FENCE WITH TENSION WIRE AND FENCE RAIL REMOVAL**

SCALE: SHEET NO. OF SHEETS STA. TO STA.

F.A. RTE.	SECTION	COUNTY	TOTAL SHEETS	SHEET NO.
VAR	2017-0311	VARIOUS	20	16
CONTRACT NO. 62F43				
FED. ROAD DIST. NO. ILLINOIS FED. AID PROJECT				

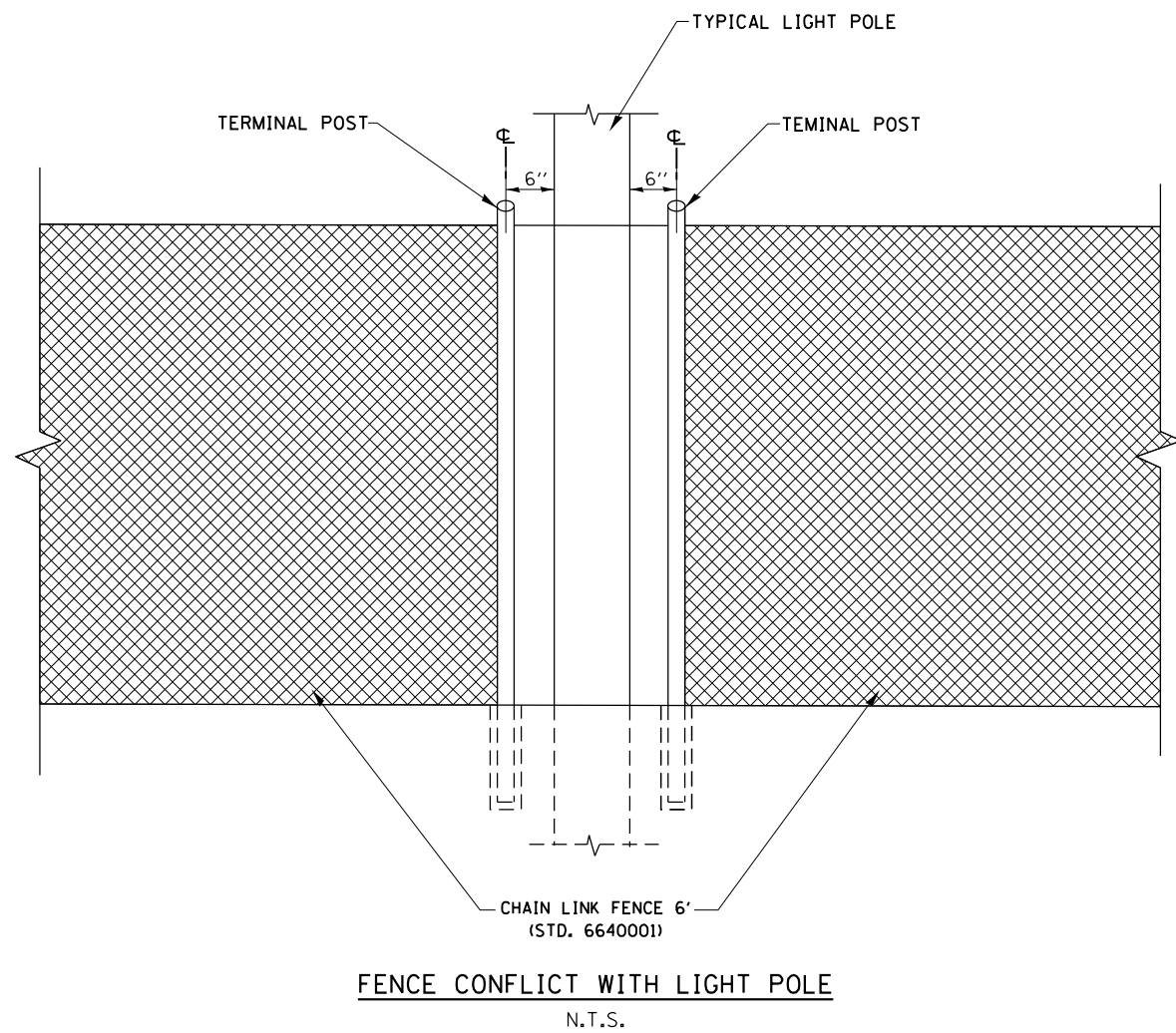

GALVANIZED POSTS SHALL CONFORM TO THE REQUIREMENTS OF STANDARD 864001 POSTS UTILIZED IN THE REPAIR WORK SHALL BE THE SAME TYPE SHAPE AS POSTS ADJACENT TO THE REPAIR AREA UNLESS OTHERWISE DIRECTED BY THE ENGINEER. NO USED MATERIALS WILL BE PERMITTED.

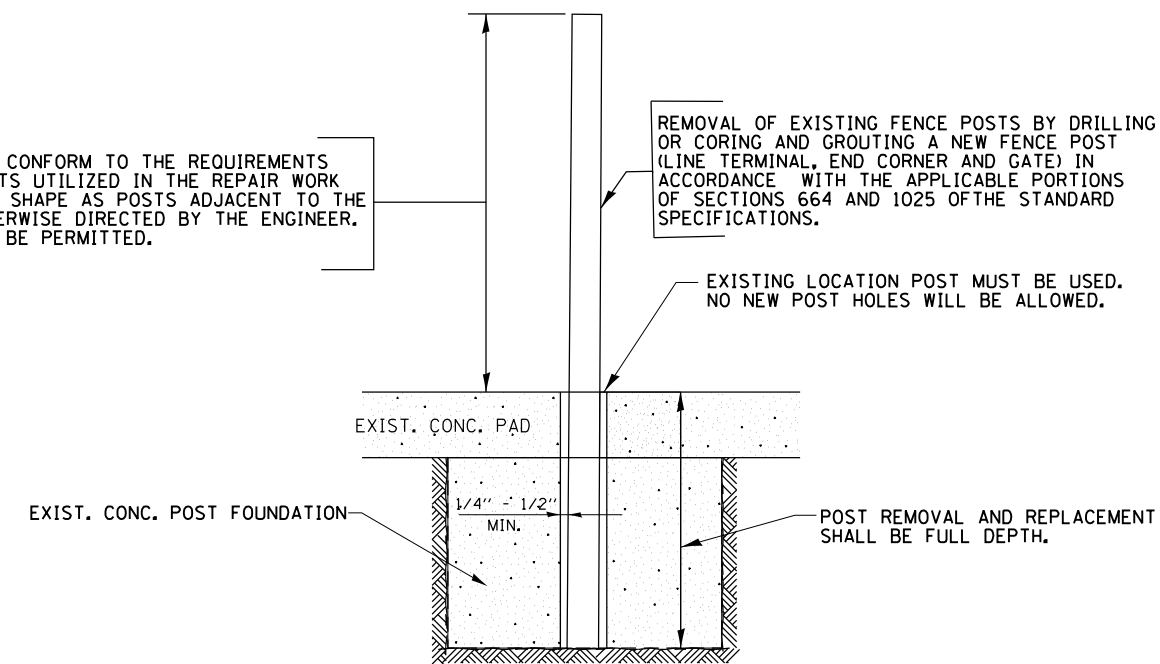

POST REMOVAL AND REPLACEMENT

FILE NAME =	USER NAME = pyzenowski	DESIGNED -	REVISED -
p:\11\084EBIDINTEG.illinois.gov\PIWIDOT\Documents\IDOT Offices\District 1\Projects\144816\Design\144816-sh-t-plan.dgn		CHECKED -	REVISED -
Default	PLOT DATE = 6/28/2017	DATE -	REVISED -

**STATE OF ILLINOIS
DEPARTMENT OF TRANSPORTATION**

SPECIAL FENCE DETAILS

SCALE: SHEET OF SHEETS STA. TO STA.

F.A. RTE.	SECTION	COUNTY	TOTAL SHEETS	SHEET NO.
VAR	2017-0311	VARIOUS	20	17
CONTRACT NO. 62F43				
ILLINOIS FED. AID PROJECT				

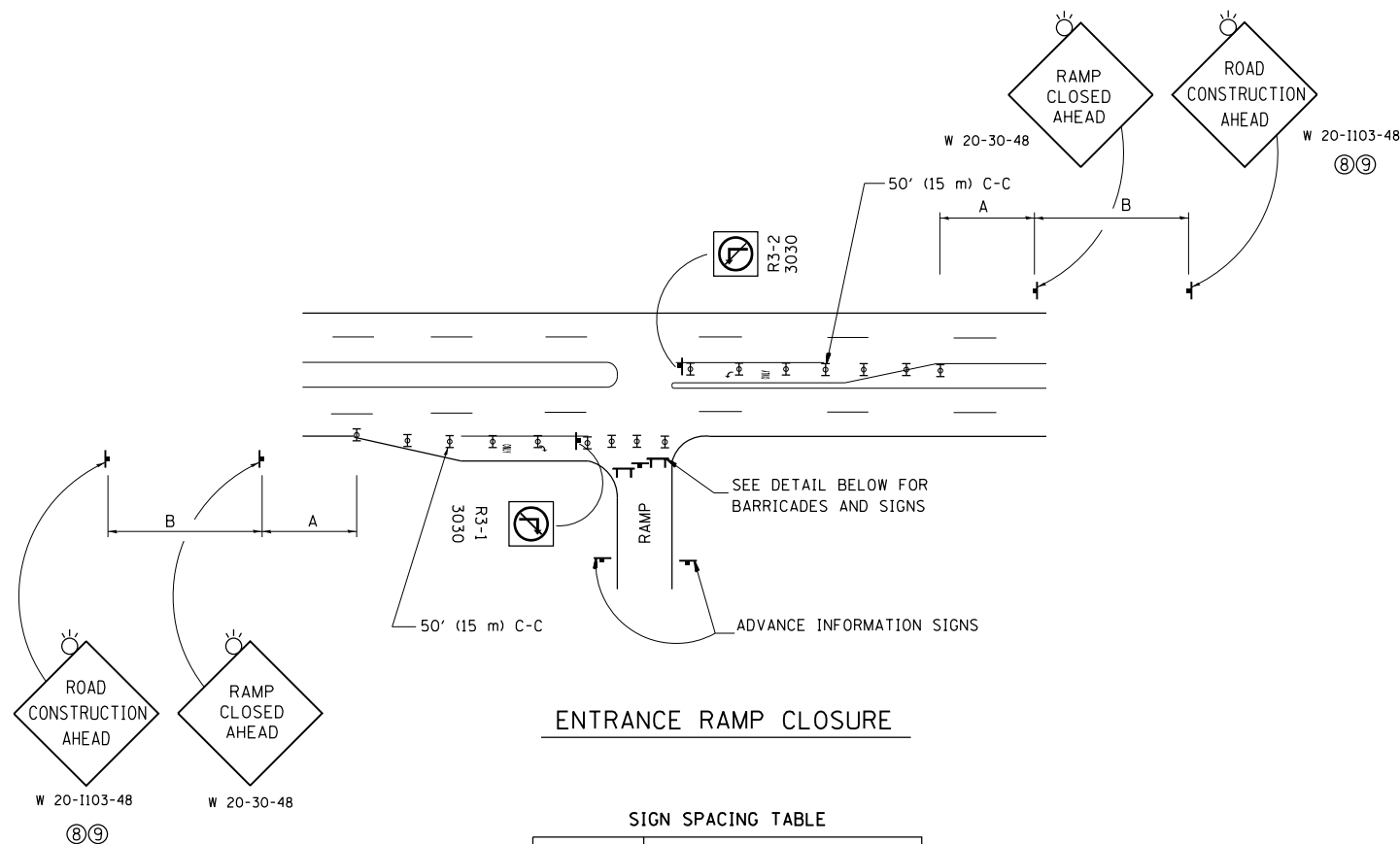

ENTRANCE RAMP CLOSURE

SIGN SPACING TABLE

FACILITY	DISTANCE BETWEEN SIGNS	
	A	B
EXPRESSWAY >24 HOURS	1000' (300 m)	1500' (450 m)
EXPRESSWAY <24 HOURS	500' (150 m)	500' (150 m)
ARTERIAL 55 MPH	500' (150 m)	500' (150 m)
ARTERIAL 50-45 MPH	350' (100 m)	350' (100 m)
ARTERIAL <45 MPH	200' (60 m)	200' (60 m)

DISTANCES MAY BE SHORTENED DEPENDING UPON THE PROXIMITY OF ADJACENT RAMPS OR INTERSECTIONS.

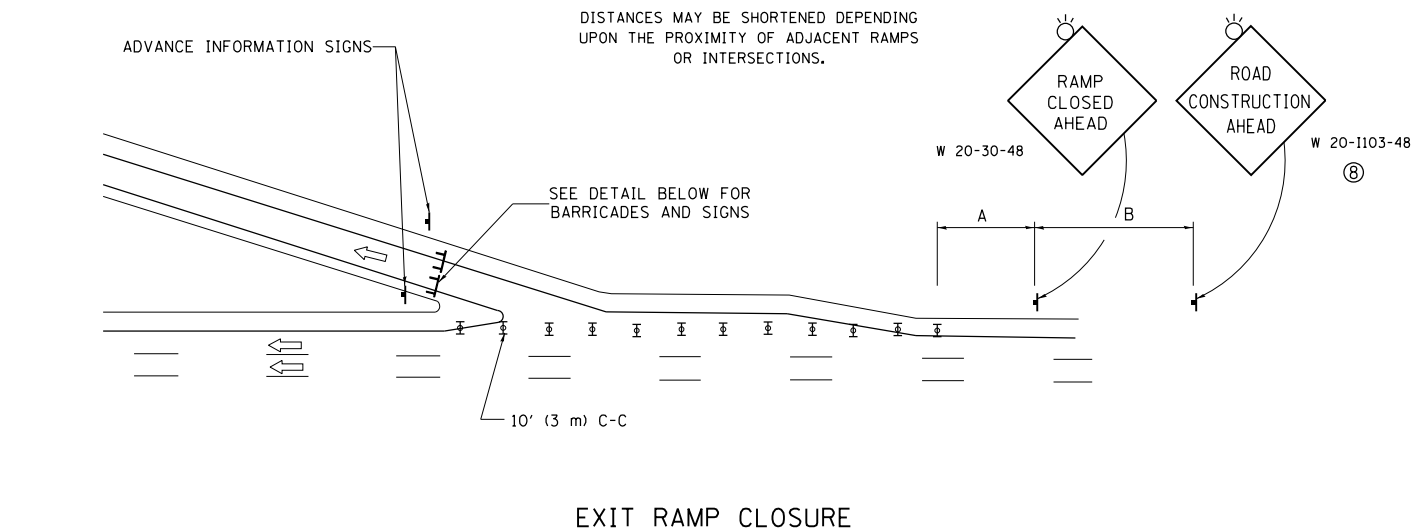

EXIT RAMP CLOSURE

SYMBOLS

- ⊥ TYPE II BARRICADE OR DRUM WITH STEADY BURN MONO-DIRECTIONAL LIGHT
- ⊓ TYPE III BARRICADE WITH 2 FLASHING LIGHTS

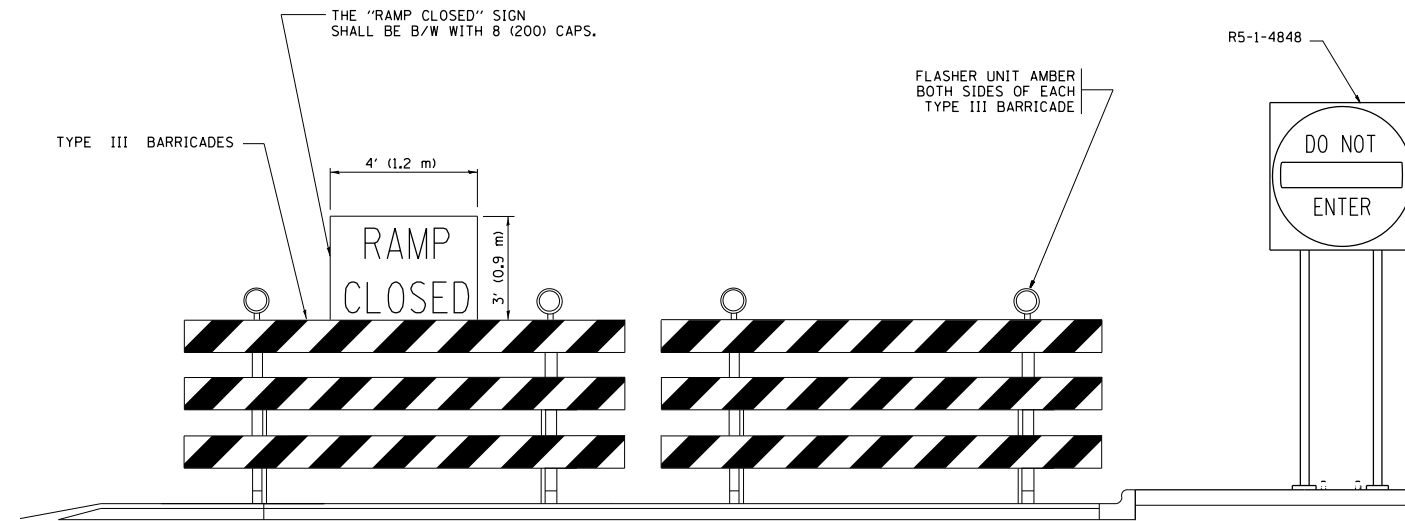

DETAIL FOR REQUIRED BARRICADES & SIGNS

RAMP CLOSURE ADVANCE WARNING SIGN

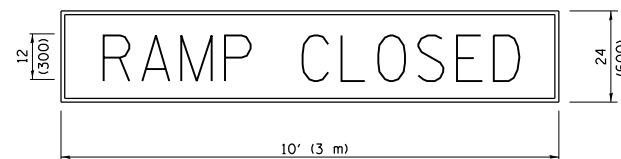

BLACK LEGEND ON ORANGE BACKGROUND MOUNTED DIAGONALLY
E MOD FONT
1 (25) BORDER
THESE SIGNS ARE REQUIRED ON ALL THE EXIT GUIDE SIGNS FOR EXIT RAMPS THAT WILL BE CLOSED FOR MORE THAN FOUR (4) CONSECUTIVE DAYS.

RAMP CLOSURE ADVANCE INFORMATION SIGN

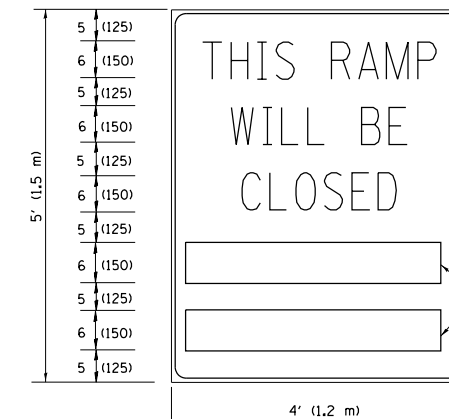

BLACK LEGEND ON WHITE BACKGROUND
1/2 (12) BORDER
E MOD FONT
THESE BLANK AREAS SHALL BE FILLED WITH THE DATES AND THE TIME THAT THE RAMP WILL BE CLOSED.

THESE SIGNS ARE REQUIRED ON BOTH SIDES OF THE RAMP, MINIMUM OF 1 WEEK IN ADVANCE OF THE CLOSURE.
THESE SIGNS SHALL BE FABRICATED AND PAID FOR ACCORDING TO THE TEMPORARY INFORMATION SIGNING SPECIAL PROVISION

GENERAL NOTES:

- ① CONES MAY BE SUBSTITUTED FOR DRUMS OR TYPE II BARRICADES DURING DAY OPERATIONS. CONES SHALL BE A MINIMUM OF 28 (700) HIGH.
- ② STEADY BURN LIGHTS WILL NOT BE REQUIRED FOR DAY OPERATIONS.
- ③ A FLAGGER SHALL BE POSITIONED AT EACH CLOSED RAMP THAT IS OPEN TO CONSTRUCTION VEHICLES, PRECEDED BY A W20-7 FLAGGER WARNING SIGN.
- ④ ALL ROUTE MARKERS AND TRAILBLAZER ASSEMBLIES WHICH DIRECT MOTORISTS TO A CLOSED ENTRANCE RAMP SHALL BE COVERED WHEN THE RAMP IS CLOSED FOR MORE THAN FOUR (4) DAYS.
- ⑤ THE SIGNING AND BARRICADING WHICH IS REQUIRED BY THIS DETAIL SHALL BE INCLUDED IN THE COST OF TRAFFIC CONTROL AND PROTECTION (EXPRESSWAYS).
- ⑥ AUTHORIZATION FROM THE DISTRICT'S BUREAU OF TRAFFIC IS REQUIRED FOR ALL RAMP CLOSURES.
- ⑦ THE RAMP CLOSURE ADVANCE INFORMATION SIGNS SHALL BE ERECTED IF THE CLOSURE TIME EXCEEDS TWENTY-FOUR (24) HOURS. ADDITIONAL ADVANCE WARNING SIGNS ON EXIT GUIDE SIGNING WILL BE REQUIRED FOR EXIT RAMP CLOSURES THAT EXCEED FOUR (4) DAYS IN LENGTH
- ⑧ ROAD CONSTRUCTION AHEAD SIGNS MAY BE OMITTED WHEN THIS DETAIL IS USED IN CONJUNCTION WITH OTHER TRAFFIC CONTROL THAT ALREADY INCLUDES A ROAD CONSTRUCTION AHEAD SIGN.
- ⑨ ARTERIAL ROAD CONSTRUCTION AHEAD SIGNS SHALL BE INSTALLED ON THE LEFT SIDE OF TRAFFIC IF THE MEDIAN IS MORE THAN 10 FT WIDE.

ALL DIMENSIONS ARE IN INCHES (MILLIMETERS) UNLESS OTHERWISE SHOWN.

FILE NAME =	USER NAME = pyrzenowski	DESIGNED - DWS	REVISED - JAF 02-06
p:\11\084EBID\INTEG\illinois.gov\PIWIDOT\Documents\IDOT Offices\District 1\Projects\014486\Design\014486-shr-plan.dgn		CHECKED -	REVISED - SPB 01-07
		DATE - 02-83	REVISED - SPB 12-09
			REVISED - MD 06-13

**STATE OF ILLINOIS
DEPARTMENT OF TRANSPORTATION**

**ENTRANCE AND EXIT RAMP
CLOSURE DETAILS**

SCALE: NONE SHEET NO. 1 OF 1 SHEETS STA. TO STA.

F.A. RTE.	SECTION	COUNTY	TOTAL SHEETS	SHEET NO.
VAR	2017-0311	VARIOUS	20	18
TC-08		CONTRACT NO. 62F43		
FED. ROAD DIST. NO. 1 ILLINOIS FED. AID PROJECT				

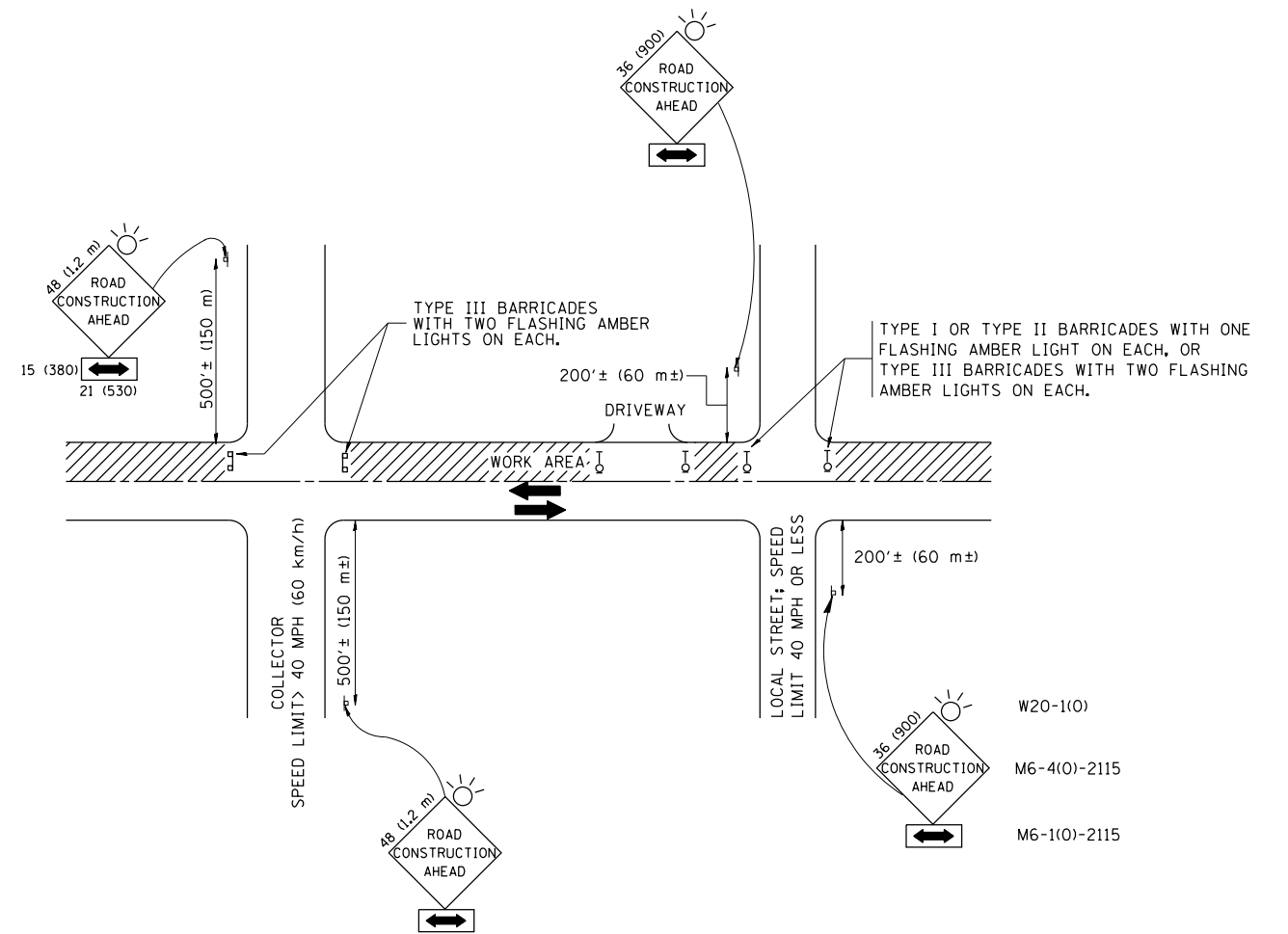

TRAFFIC CONTROL AND PROTECTION FOR SIDE ROADS, INTERSECTIONS, AND DRIVEWAYS

NOTES:

A. FOR NO LANE RESTRICTION ON THE SIDE ROAD OR DRIVEWAYS

1. SIDE ROAD WITH A SPEED LIMIT OF 40 MPH (60 km/h) OR LESS AS SHOWN ON THE DRAWING AND AS DIRECTED BY THE ENGINEER:

a) ONE ROAD CONSTRUCTION AHEAD SIGN 36 x 36 (900x900) WITH A FLASHER AND FLAG MOUNTED ON IT APPROXIMATELY 200' (60 m) IN ADVANCE OF THE MAIN ROUTE.

b) THE CLOSED PORTION OF THE MAIN ROUTE SHALL BE PROTECTED BY BLOCKING WITH TYPE I, TYPE II OR TYPE III BARRICADES, 1/3 OF THE CROSS SECTION OF THE CLOSED PORTION.

2. SIDE ROAD WITH A SPEED LIMIT GREATER THAN 40 MPH (60 km/h) AS SHOWN ON THE DRAWING AND AS DIRECTED BY THE ENGINEER:

a) ONE ROAD CONSTRUCTION AHEAD SIGN 48 x 48 (1.2 m x 1.2 m) WITH A FLASHER MOUNTED ON IT APPROXIMATELY 500' (150 m) IN ADVANCE OF THE MAIN ROUTE.

b) THE CLOSED PORTION OF THE MAIN ROUTE SHALL BE PROTECTED BY BLOCKING WITH TYPE III BARRICADES, 1/2 OF THE CROSS SECTION OF THE CLOSED PORTION.

3. WHEN THE SIDE ROAD LIES BETWEEN THE BEGINNING OF THE MAINLINE SIGNING AND THE WORK ZONE, A SINGLE HEADED ARROW (M6-1) SHALL BE USED IN LIEU OF THE DOUBLE HEADED ARROW (M6-4).

B. FOR A LANE CLOSURE ON A SIDE ROAD OR DRIVEWAY:

USE APPLICABLE PORTIONS OF THE TYPICAL APPLICATION OF TRAFFIC CONTROL DEVICES (STD. 701501, STD. 701606 OR THE APPROPRIATE STANDARD). THE SPACING OF SIGNS AND BARRICADES SHALL BE ADJUSTED FOR FIELD CONDITIONS AS DIRECTED BY THE ENGINEER. THE DIRECTIONAL ARROW SHALL BE COVERED OR REMOVED WHEN NO LONGER CONSISTENT WITH THE SIDE ROAD LANE CLOSURE.

C. ADVANCE WARNING SIGNS ARE TO BE OMITTED ON DRIVEWAY UNLESS OTHERWISE NOTED.

D. THE TRAFFIC CONTROL AND PROTECTION FOR SIDE ROADS, INTERSECTIONS, AND DRIVEWAYS SHALL BE INCIDENTAL TO THE COST OF SPECIFIED TRAFFIC CONTROL STANDARDS OR ITEMS.

All dimensions are in millimeters (inches) unless otherwise shown.

FILE NAME =	USER NAME = pyrzenowski	DESIGNED - -	REVISED - -
p:\11\084EBIDINTEG\illinois.gov\PIWIDOT\Documents\IDOT Offices\District 1\Projects\D1448\Drawings\Design\144816-sht-plan.dgn		CHECKED - -	REVISED - -
		DATE - -	REVISED - -

STATE OF ILLINOIS
DEPARTMENT OF TRANSPORTATION

TRAFFIC CONTROL AND PROTECTION FOR
SIDE ROADS, INTERSECTIONS, AND DRIVEWAYS

SCALE: NONE SHEET NO. 1 OF 1 SHEETS STA. TO STA.

F.A. RTE.	SECTION	COUNTY	TOTAL SHEETS	SHEET NO.
VAR	2017-0311	VARIOUS	20	19
TC-10			CONTRACT NO. 62F43	
FED. ROAD DIST. NO. 1 ILLINOIS FED. AID PROJECT				

PARTIAL RAMP CLOSURE DETAILS

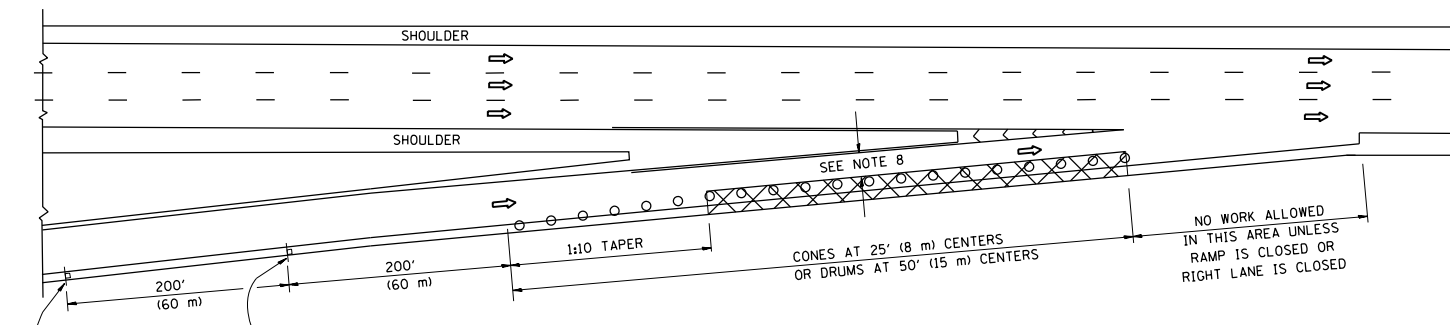

TYPICAL ENTRANCE RAMP

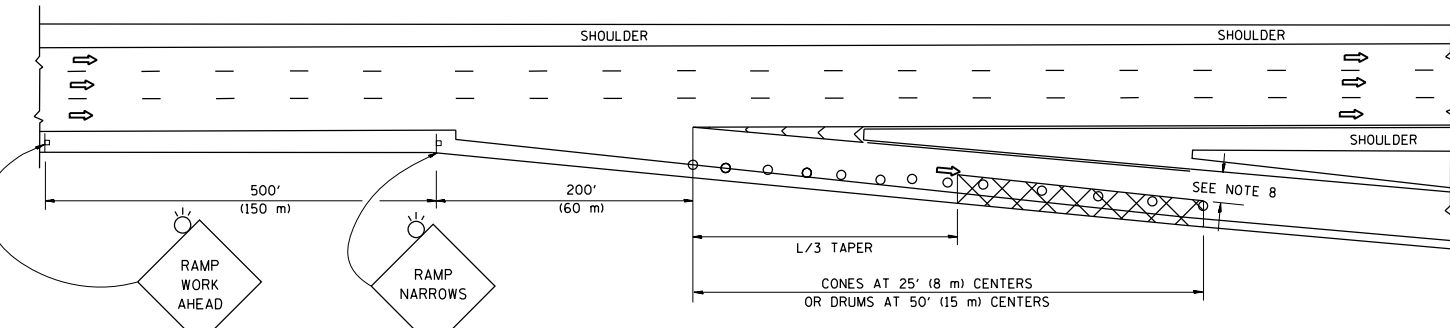

TYPICAL EXIT RAMP

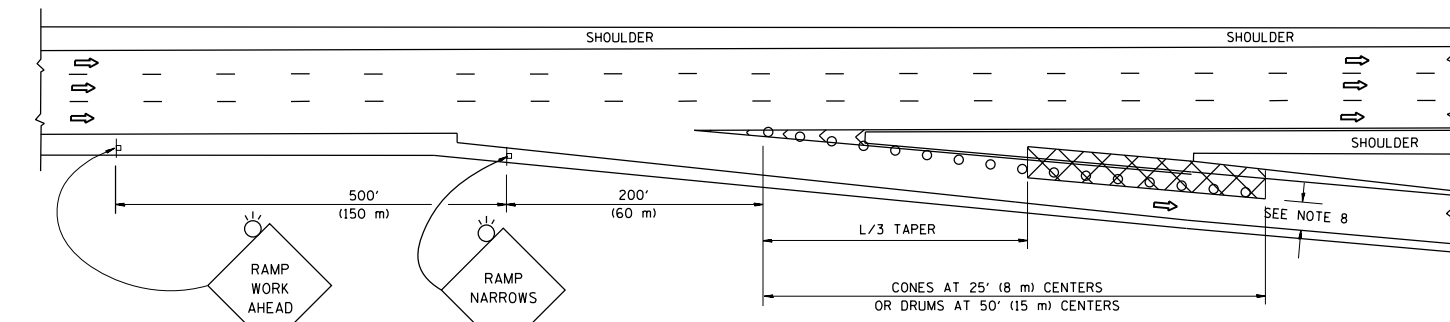

TYPICAL EXIT RAMP

SYMBOLS

- ACTIVE WORK AREA
- SIGN ON PORTABLE OR PERMANENT SUPPORT
- FLAGGER WITH CONTROL SIGN
- TYPE II BARRICADE OR DRUM WITH STEADY BURN MONO-DIRECTIONAL LIGHT
- CONE, DRUM OR BARRICADE
- IMPACT ATTENUATOR OF TYPE AND TEST LEVEL SPECIFIED

GENERAL NOTES

1. THE "L" DISTANCE EQUALS:

SPEED LIMIT	FORMULAS
45 mph (80 km/h)	METRIC ENGLISH
OR GREATER:	$L=0.65(W)(S)$ $L=(W)(S)$

W = WIDTH OF OFFSET IN FEET (METERS)
 S = NORMAL POSTED SPEED MPH (KM/H)
2. PLASTIC DRUMS WITH HIGH PERFORMANCE REFLECTIVE SHEETING AND STEADY BURNING LIGHTS ARE REQUIRED FOR ALL NIGHTIME CLOSURES.
3. ALL SIGNS SHALL BE POST MOUNTED IF THE CLOSURE TIME EXCEEDS FOUR DAYS.
4. FLASHING LIGHTS SHALL BE USED DURING THE HOURS OF DARKNESS AND SHALL BE INSTALLED ABOVE THE FIRST TWO SETS OF SIGNS.

SHOULDER CLOSURE DETAILS

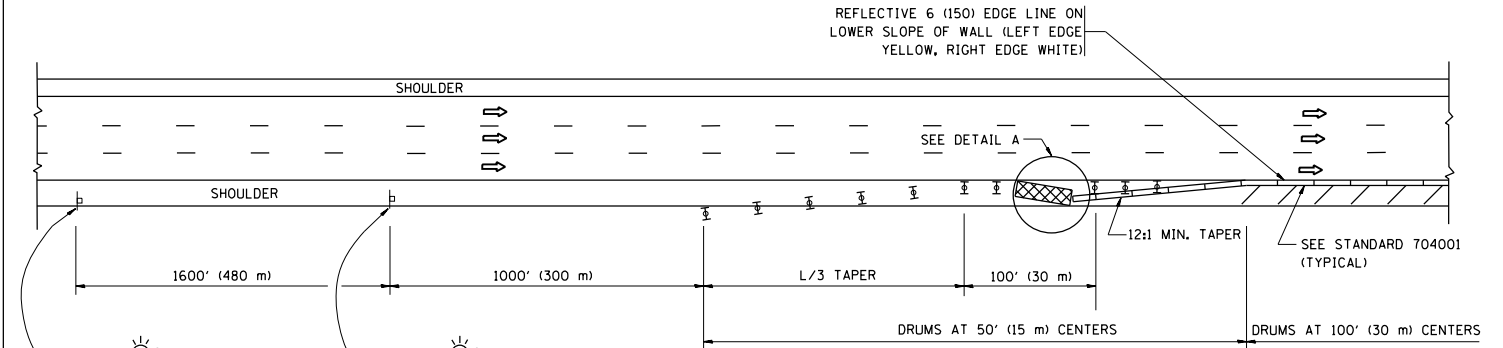

PERMANENT SHOULDER CLOSURE

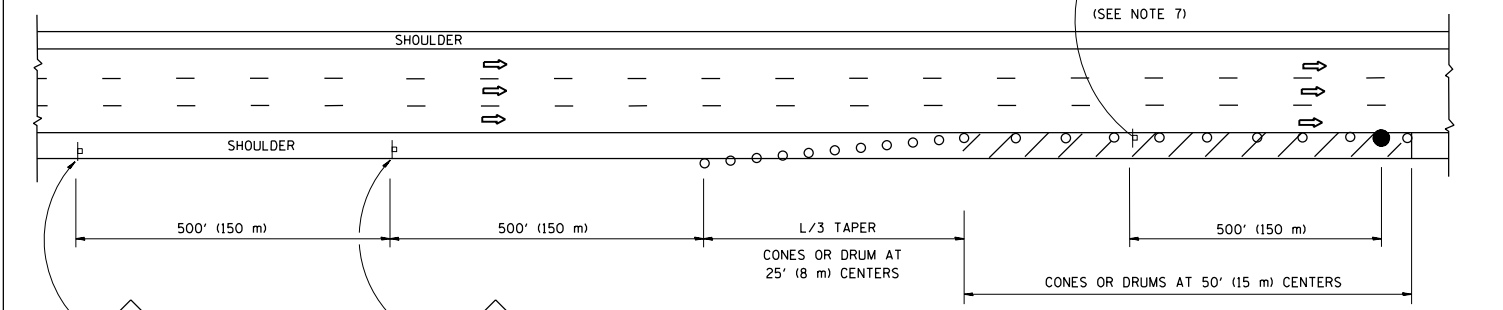

DAYTIME SHOULDER CLOSURE

THIS DETAIL IS USED WHERE:
 1. VEHICLES, EQUIPMENT, WORKERS OR THEIR ACTIVITIES ENCRANCH IN AN AREA CLOSER THAN 15' (4.5 m) TO THE EDGE OF PAVEMENT FOR A PERIOD IN EXCESS OF 15 MINUTES.

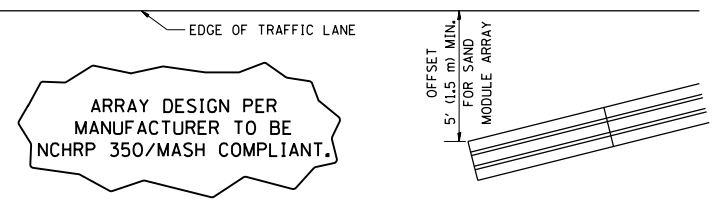

DETAIL "A"
 IMPACT ATTENUATOR, TEMPORARY
 (SEE NOTE 5)

5. THE IMPACT ATTENUATOR, TEMPORARY IS NOT REQUIRED WHEN THE TEMPORARY CONCRETE BARRIER WALL IS PROTECTED BY OR IS TIED INTO THE EXISTING GUARDRAIL. IF OFFSET IS LESS THAN 5 FEET USE NARROW USE TYPE DEVICE TO MEET NCHRP350/MASH.
6. AUTHORIZATION FROM THE DISTRICT'S BUREAU OF TRAFFIC IS REQUIRED FOR ALL FREEWAY CLOSURES.
7. THE FLAGGER AND FLAGGER SIGN ARE REQUIRED AT THE ABOVE WORK SITES WHEN:
 - a. FOUR OR MORE WORK VEHICLES ENTER THE TRAFFIC LANES IN A ONE HOUR PERIOD.
 - b. THE WORK AVTIVITY REQUIRES FREQUENT ENCRACHMENT INTO THE LANE OPEN TO TRAFFIC.
 THE FLAGGER SHALL BE STATIONED APPROXIMATELY 100' (30 m) TO 200' (60 m) IN ADVANCE OF THE WORKERS.
8. 12' MIN. WIDTH TANGENT SECTION
 16' MIN. WIDTH CURVE SECTION.

ALL DIMENSIONS ARE IN INCHES (MILLIMETERS) UNLESS OTHERWISE SHOWN.

FILE NAME =	USER NAME = pyrzenowski	DESIGNED -	REVISED -	STATE OF ILLINOIS DEPARTMENT OF TRANSPORTATION	TRAFFIC CONTROL DETAILS FOR FREEWAY SHOULDER CLOSURES AND PARTIAL RAMP CLOSURES			F.A. RTE.	SECTION	COUNTY	TOTAL SHEETS	SHEET NO.	
pw\11084EBIDINTEG.illinois.gov\PI\DOT\Documents\DOT Offices\District 1\Projects\1448\Design\144816-shr-plan.dgn		CHECKED -	REVISED -		SCALE: NONE	SHEET NO. 1 OF 1 SHEETS	STA.	TO STA.	VAR	2017-0311	VARIOUS	20	20
PLOT SCALE = 100.0000' / in.		DATE -	REVISED -						TC-17		CONTRACT NO. 62F43		
PLOT DATE = 6/28/2017			REVISED - M.D. 06-13						FED. ROAD DIST. NO. 1 ILLINOIS FED. AID PROJECT				