

STATE OF ILLINOIS
DEPARTMENT OF TRANSPORTATION

ROUTE NO.	SECTION	COUNTY	TOTAL SHEETS	SHEET NO.	SHEET NO.
F.A.P. 817	8BR-2, 8BR-3	WASHINGTON	52	44	9 SHEETS
FED. ROAD DIST. NO. 7	ILLINOIS	FED. AID PROJECT-			

Contract #76946

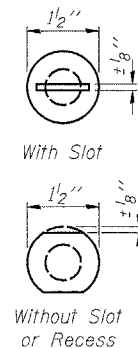
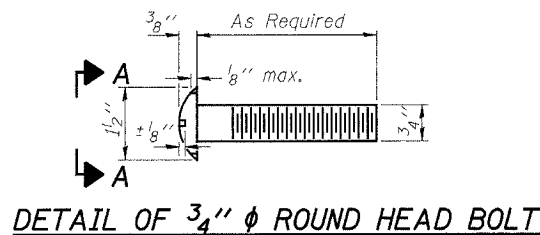

VIEW A-A

4- 3/4" ϕ x 6" Round Head Bolts (With slot or approved recess in head) with locknut & flat washer. 7/8" ϕ holes in hollow structural section may be drilled in the field.

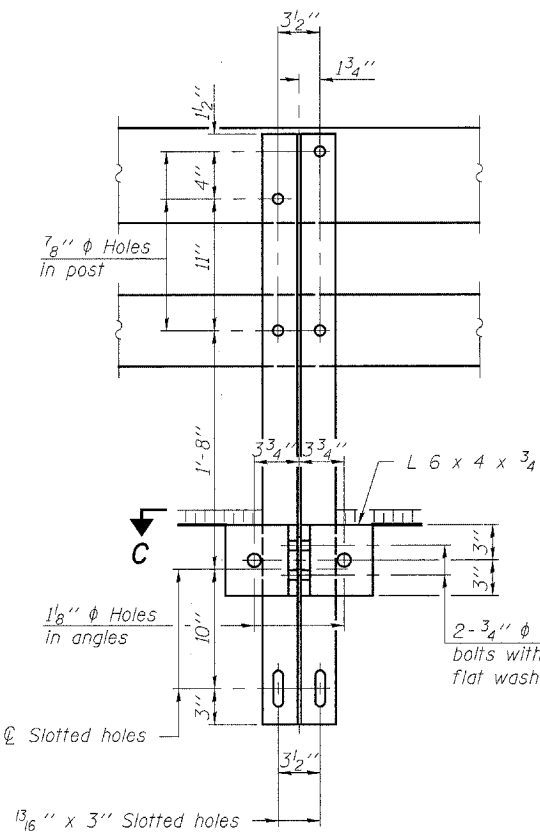

SECTION B-B

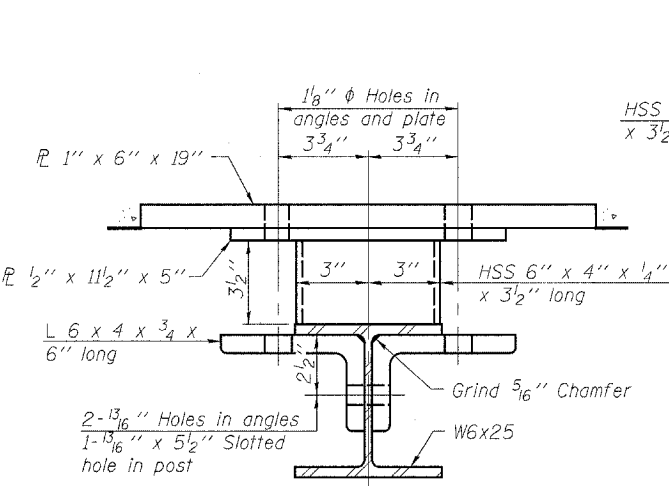

SECTION C-C

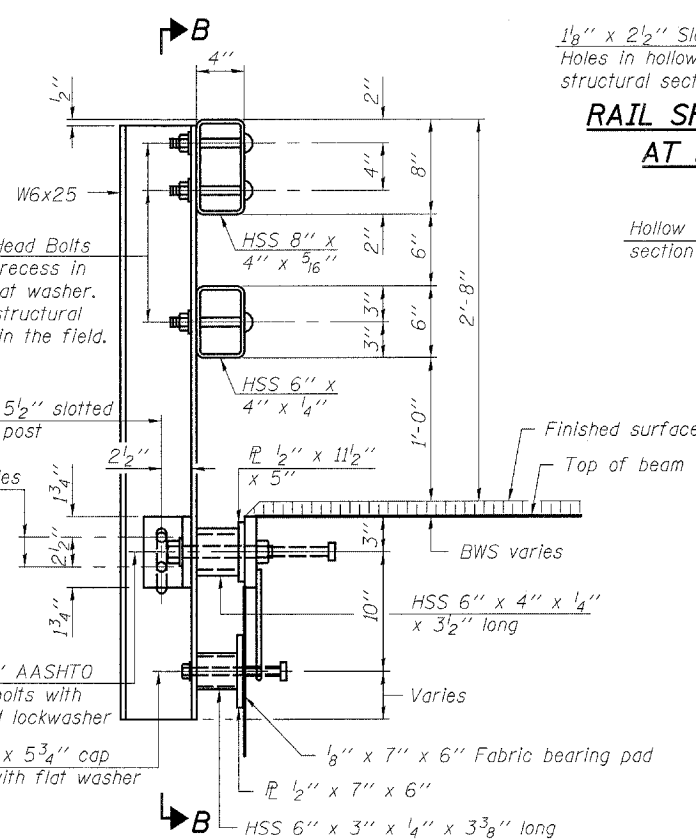

SECTION AT RAIL POST

DESIGNED	EML
CHECKED	NJM
DRAWN	EML
CHECKED	NJM

HORNER & SHIFRIN, INC.
ENGINEERS ■ ARCHITECTS ■ PLANNERS

R-34BWS

10-28-05 (6'-3" Maximum Post Spacing) (1/4" minimum to 3/8" maximum BWS thickness)

RAIL SPLICE CONNECTION
AT EXPANSION JT.

1/8" x 2 1/2" Slotted Holes in hollow structural section

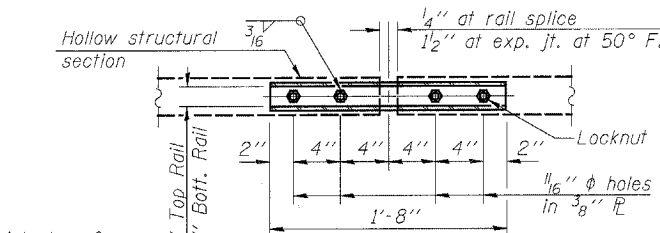

PLAN-BOTT. SPLICE P
TYPICAL

4 - 5/8" reduced base welded studs. Provide 4 - 5/8" washers and self-locking nuts or nuts and jam nuts for guardrail connection shown on Std. 631032

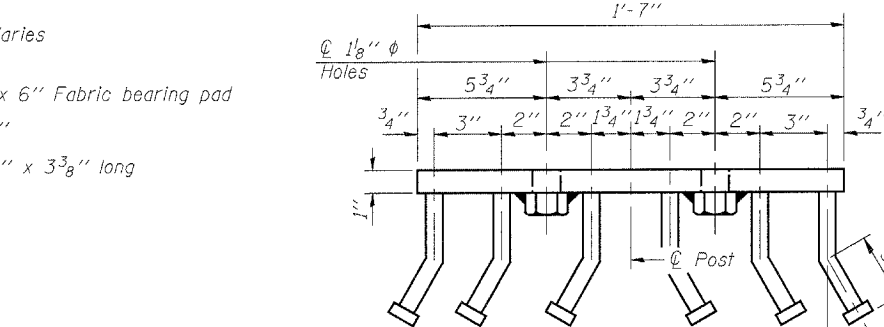

VIEW D-D

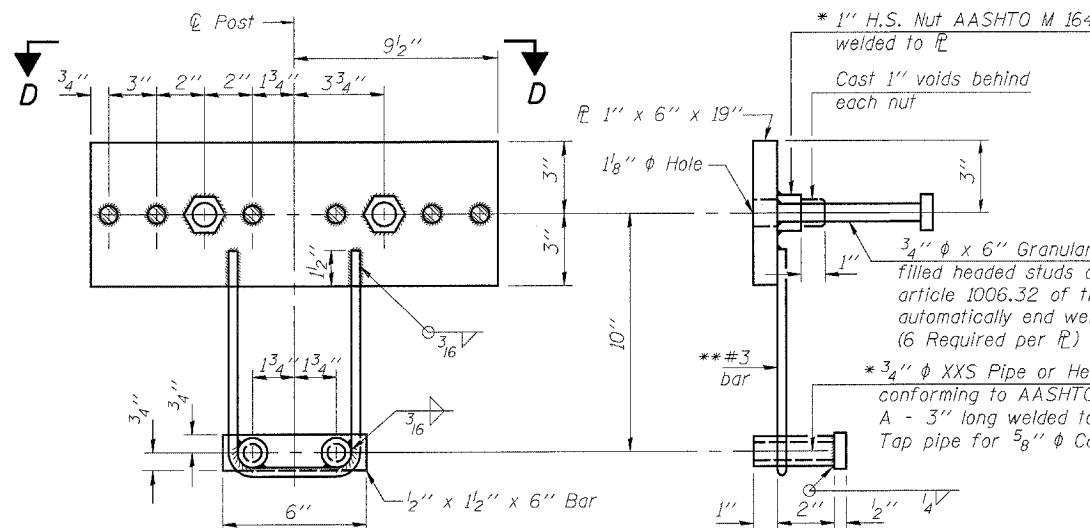

ANCHOR DEVICE

* Threaded areas shall be plugged or blocked off during casting of beam. Galvanized after fabrication.

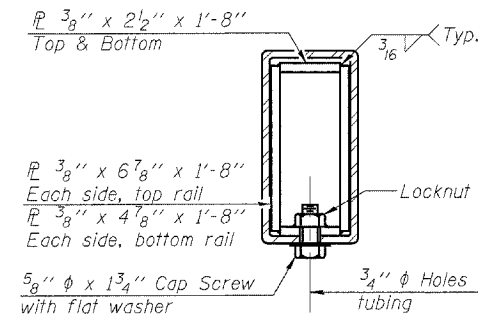

SECTION AT
RAIL SPLICE

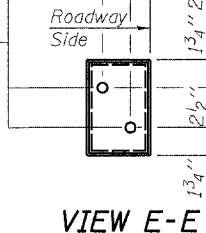

VIEW E-E

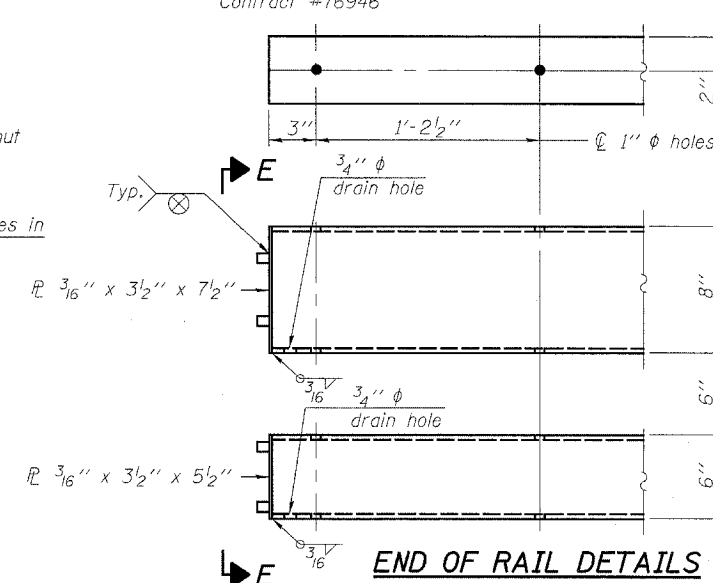

NOTES

Hollow structural sections shall conform to the requirements of ASTM designation A 500 Grade B Structural Steel Tubing and shall meet the longitudinal CVN requirements of 15 ft-lbs at 0° F. All other steel shapes and plates shall conform to the requirements of AASHTO M 270 Grade 36 except posts and angles shall conform to AASHTO M 270, Grade 50. Bolts, cap screws, and nuts shall conform to the requirements of ASTM designation A 307 except for high strength bolts, nuts and washers noted which shall conform to AASHTO M 164. All bolts, nuts, cap screws, washers and lock washers shall be galvanized according to AASHTO M 232. All posts, railing, rail splices, anchor devices and angles shall be galvanized after shop fabrication according to AASHTO M 111 and ASTM A 385. Galvanized rail shall not be painted. Railing shall be according to Section 509 of the Standard Specifications, except as noted, and will be paid for at the contract unit price per foot for Steel Bridge Rail, Type SM. All field drilled holes shall be coated with an approved zinc rich paint before erection. For multi-span bridges, sufficient 1/4" x 6" x 1'-2" galvanized steel shims shall be provided to align rail between adjacent spans. Cost included with Steel Bridge Rail, Type SM. The 3/4" ϕ high strength bolts used to connect the 6 x 4 x 3/4 angles to the post shall be tightened according to Article 505.04(f)(2) of the Standard Specifications. The 1" ϕ high strength bolts connecting the angles to the concrete shall be tightened to a snug fit and given an additional 1/8 turn. The 5/8" ϕ cap screws in bottom of posts shall be tightened to a snug fit only. For rail post spacing, see sheet 5 and 6 of 9.

BILL OF MATERIAL

Item	Unit	Quantity
Steel Bridge Rail, Type SM	Foot	126

TYPE SM
STEEL BRIDGE RAIL SIDE MOUNTED
F.A.P. ROUTE 817 - SECTION 8BR-3
WASHINGTON COUNTY
STATION 36+12.71
STRUCTURE NO. 095-0011

** Whenever the lower insert assemblies interfere with strand locations, the #3 bars shall be cut and adjusted in order to allow raising or lowering of the lower inserts. Maximum adjustment not to exceed 1/2".