

PAVEMENT THICKNESS T - INCHES	DEPTH OF CONTRACTION JOINT INITIAL SAW CUT 1, INCHES $1=(T/3) \pm 1/4"$
5	1.67"
6	2.00"
7	2.33"
8	2.67"
9	3.00"
10	3.33"
11	3.67"
12	4.00"
13	4.33"
14	4.67"
15	5.00"
16	5.33"
17	5.67"
18	6.00"

EXPANSION JOINTS

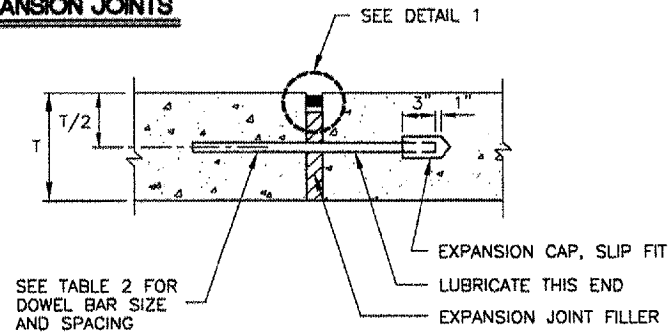

TYPE A DOWELED
SYMBOL

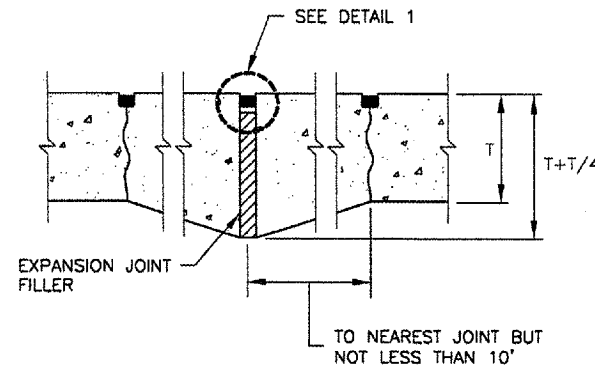

TYPE B THICKENED EDGE
SYMBOL

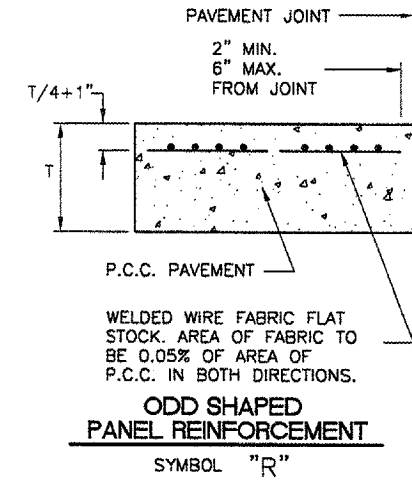

CA004
K:\Springfield\0703502_SPI_TTY_F\Draw\Sheets
FILE: JNTDTL.dwg
UPDATE BY: Dave Allen
PLOT DATE: 8/3/2007 1:26 PM
SPI_LOGO

NUMBER	BY	DATE

0 1 2
THIS BAR IS EQUAL TO 2" AT FULL SCALE (34X22).

PAVEMENT THICKNESS T - INCHES	DOWEL BAR DETAILS			TIE BAR DETAILS		
	DIA.	LENGTH	SPACING	BAR SIZE	LENGTH	SPACING
5	5/8"	12"	12"	#4	24"	30"
6	3/4"	18"	12"	#5	30"	30"
7	3/4"	18"	12"	#5	30"	30"
8	1"	19"	12"	#5	30"	30"
9	1"	19"	12"	#5	30"	30"
10	1"	19"	12"	#5	30"	30"
11	1"	19"	12"	#5	30"	30"
12	1"	19"	12"	#5	30"	30"
13	1 - 1/4"	20"	15"	#5	30"	30"
14	1 - 1/4"	20"	15"	#5	30"	30"
15	1 - 1/4"	20"	15"	#5	30"	30"
16	1 - 1/4"	20"	15"	#5	30"	30"
17	1 - 1/2"	20"	18"	#5	30"	30"
18	1 - 1/2"	20"	18"	#5	30"	30"

CONSTRUCTION JOINTS

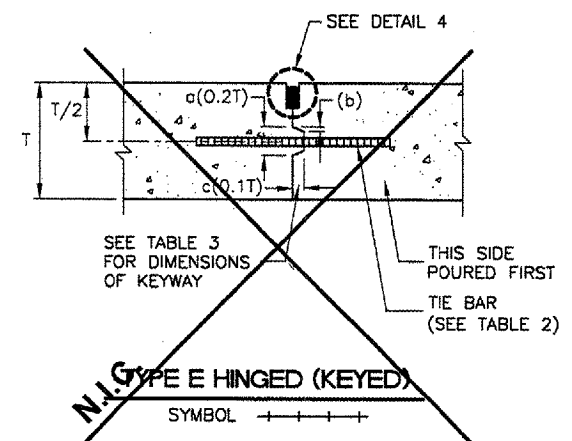
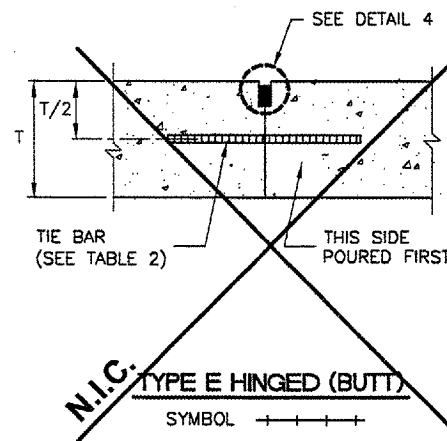
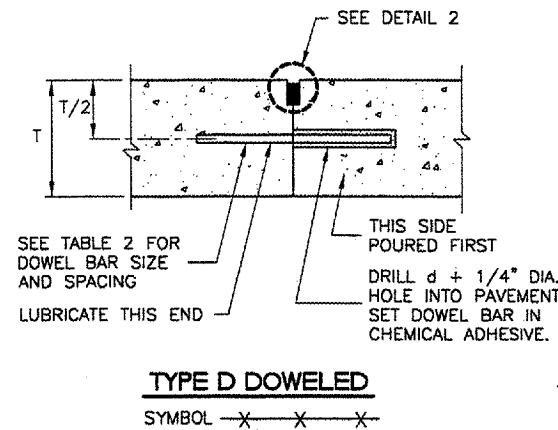
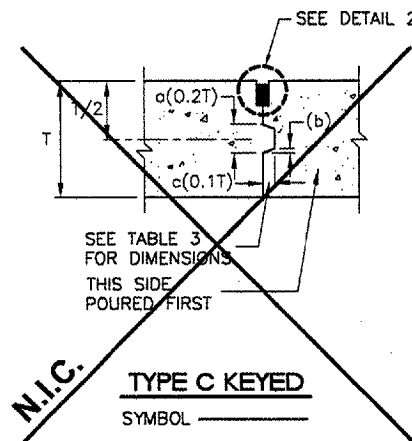

CONTRACTION JOINTS

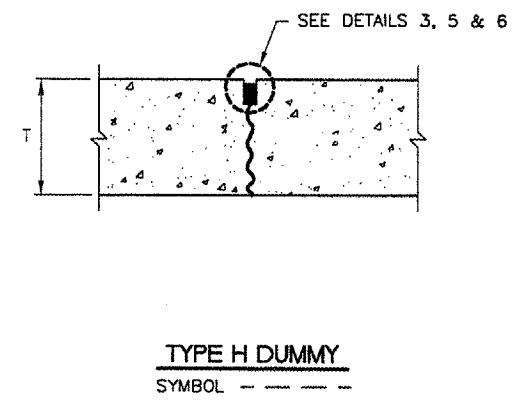
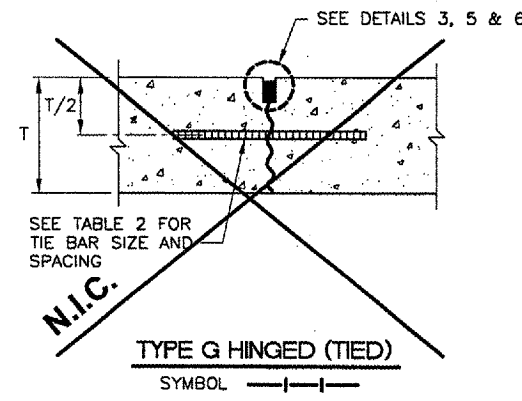
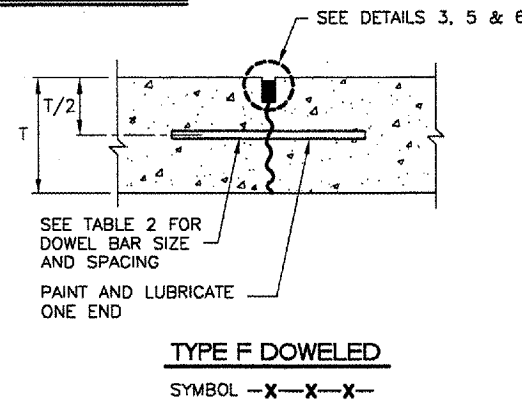

PAVEMENT THICKNESS T - INCHES	KEYED JOINT DIMENSIONS		
	a	b	c
6	—	—	—
7	—	—	—
8	0.133' (1-5/8" ±)	0.017' (3/16" ±)	0.067' (7/8" ±)
9	0.150' (1-13/16" ±)	0.019' (3/16" ±)	0.075' (7/8" ±)
10	0.167' (2")	0.021' (1/4" ±)	0.083' (1")
11	0.183' (2-13/16" ±)	0.023' (1/4" ±)	0.092' (1-1/8" ±)
12	0.200' (2-3/8" ±)	0.025' (5/16" ±)	0.100' (1-1/4" ±)
13	0.217' (2-5/8" ±)	0.027' (5/16" ±)	0.108' (1-5/16" ±)
14	0.233' (2-13/16" ±)	0.029' (3/8" ±)	0.117' (1-7/16" ±)
15	0.250' (3")	0.031' (3/8" ±)	0.125' (1-1/2" ±)
16	0.267' (3-13/16" ±)	0.033' (7/16" ±)	0.133' (1-5/8" ±)

JOINT NOTES

- 1.) ALL EDGES OF NEW SLABS, FREE STANDING OR CLOSURE, SHALL BE EDGED WITH AN APPROVED TOOL HAVING A RADIUS OF 1/8" TO 1/4" TO FACILITATE SAWING OF THE SEALANT RESERVOIR. A RADIUS > 1/4" WILL NOT BE ACCEPTABLE.
- 2.) THE INITIAL SAWCUT FOR ALL LONGITUDINAL & TRANSVERSE CONTRACTION JOINTS SHALL BE SAWS AS SOON AS POSSIBLE AFTER PLACEMENT OF THE PAVEMENT.
- 3.) ALL TIE BARS & MESH SHALL BE SECURELY HELD IN PLACE BY SUPPORT PINS OR OTHER APPROVED METHODS TO PREVENT SHIFTING DURING & AFTER CONCRETE PLACEMENT.
- 4.) TIE BARS SHALL BE DEFORMED BARS IN CONFORMANCE WITH THE SPECIFICATIONS.
- 5.) THE INITIAL SAWCUT SHALL BE MADE TO THE 1/8" WIDTH INDICATED. INITIAL SAWING TO THE DIMENSIONS OF THE SECOND SAWCUT WILL NOT BE ALLOWED.

	DETAIL 1	DETAIL 2	DETAIL 3	DETAIL 4	DETAIL 5
	HOT/ COLD POUR	HOT/ COLD POUR	HOT/ COLD POUR	HOT/ COLD POUR	PRE-FORMED
W=WIDTH OF SEALANT RESERVOIR (IN.)	1	1/2	1/2	1/2	3/8 (COM-PRESSED)
D=DEPTH OF SEALANT RESERVOIR (IN.)	1	1/2	1/2	1/2	N/A
B=BACKER ROD DIAMETER (IN.)	N/A	5/8	5/8	N/A	N/A
S=SECOND SAWCUT DEPTH (IN.) MINIMUM	N/A	1-3/8	1-3/8	3/4	1-1/2

JOINT SEALING DETAILS

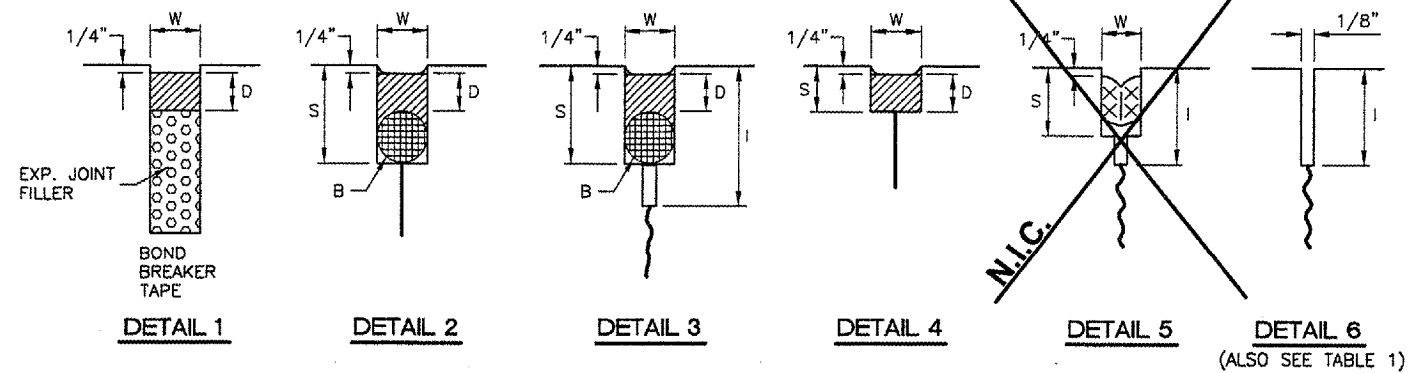

N.I.C. - NOT IN CONTRACT



SPRINGFIELD AIRPORT AUTHORITY
ABRAHAM LINCOLN CAPITAL AIRPORT
SPRINGFIELD, ILLINOIS

WIDEN TAXIWAY F
JOINTING DETAILS

© Copyright CMT, Inc.
CMT
CRAWFORD, MURPHY & TILLY, INC.
CONSULTING ENGINEERS
License No. 184-00865

DESIGN BY: RLV
DRAWN BY: CMT
CHECKED BY: RLV
APPROVED BY: RLV
DATE: AUGUST 07, 2007
JOB No: 07035-02-00

IL PROJ. NO. SPI-3711
AIP PROJ. NO. 3-17-0096-XX
SHEET 15 OF 31 SHEETS