

REVISIONS

| NUMBER | BY | DATE |
|--------|----|------|
| | | |
| | | |
| | | |

0 1 2
 THIS BAR IS EQUAL TO 2"
 AT FULL SCALE (34X22).



SPRINGFIELD AIRPORT AUTHORITY
 ABRAHAM LINCOLN CAPITAL AIRPORT
 SPRINGFIELD, ILLINOIS

WIDEN TAXIWAY F

CONSTRUCTION ACTIVITY PLAN DETAILS

© Copyright CMT, Inc.
CMT
 CRAWFORD, MURPHY & TILLY, INC.
 CONSULTING ENGINEERS
 License No. 184-000613

| | |
|---------------|-----------------|
| DESIGN BY: | RLV |
| DRAWN BY: | CMT |
| CHECKED BY: | <i>RLV</i> |
| APPROVED BY: | <i>RLV</i> |
| DATE: | AUGUST 07, 2007 |
| JOB No: | 07035-02-00 |
| IL PROJ. NO. | SPI-3711 |
| AIP PROJ. NO. | 3-17-0096-XX |
| SHEET | 06 OF 31 SHEETS |

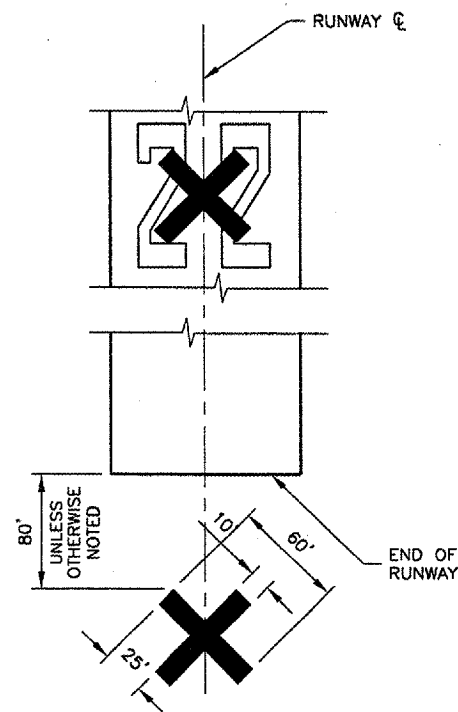

**PORTABLE CLOSED RUNWAY
 MARKER DETAIL AND NOTES**
 N.T.S.

NOTES

1. THE AIRPORT WILL PROVIDE PORTABLE LIGHTED CLOSURE MARKERS FOR THE CONTRACTOR'S USE.
2. THE CONTRACTOR WILL BE REQUIRED TO TOW AND SET UP THE MARKERS AT THE ENDS OF THE RUNWAY WHENEVER RUNWAY CLOSURES ARE REQUIRED
3. THE CONTRACTOR WILL BE REQUIRED TO PROVIDE REPLACEMENT BULBS, FUEL AND DAILY/PERIODIC MAINTENANCE INSPECTIONS AS REQUIRED BY THE AIRPORT.
4. THE AIRPORT WILL PERFORM PERIODIC MAINTENANCE, PROVIDE REPLACEMENT PARTS AND PERFORM REPAIRS AS REQUIRED TO KEEP THE EQUIPMENT OPERATIONAL.
5. THE COST OF SET-UP, FUELING AND REMOVAL OF THE MARKERS SHALL BE INCIDENTAL TO THE CONTRACT.
6. MARKERS SHALL BE PLACED OVER EXISTING RUNWAY NUMERALS. HOWEVER, WHEN WORK IS NECESSARY FOR THAT AREA OR PAVEMENT IS OPEN TO TAXIING AIRCRAFT, THE MARKERS SHALL BE RELOCATED OFF THE PAVEMENT AS SHOWN ON THE DETAIL.

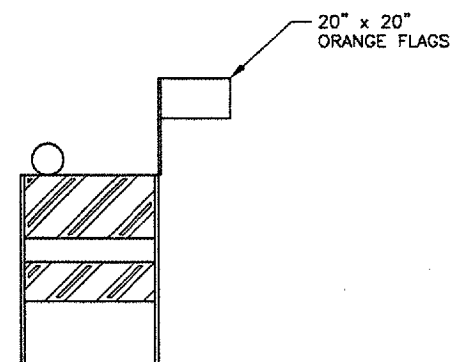

FLASHER BARRICADE DETAIL
 N.T.S.

FLASHER BARRICADE NOTES

1. FLASHERS TO BE BATTERY OPERATED. LENS TO BE RED AND BE ABLE TO ROTATE 90 DEGREES.
2. SANDBAGS TO BE PLACED ON EACH SUPPORT BRACE AS REQUIRED TO PREVENT DISPLACEMENT BY WIND, JET OR PROP BLAST.
3. NO SEPARATE PAYMENT WILL BE MADE FOR THIS ITEM. COSTS SHALL BE CONSIDERED INCIDENTAL TO THE PROJECT.
4. PLACE AT 20' INTERVALS.

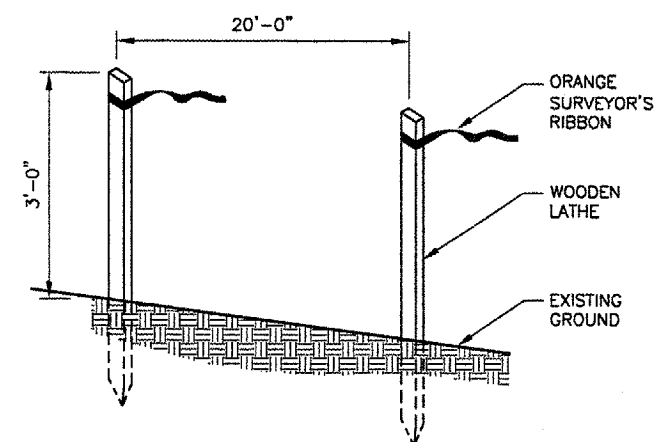

CONSTRUCTION SETBACK LINE DETAIL
 N.T.S.