

SECTION	COUNTY	TOTAL SHEETS	SHEET NO.
00-00048-00-B1	COOK	39	22
STA. 9+95	TO STA. 31+58		
FED. ROAD DIST. NO. 1	ILLINOIS	FED. AID PROJECT	
CONTRACT NO. 83864			

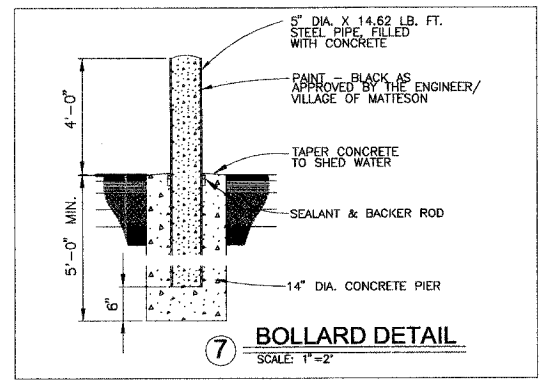
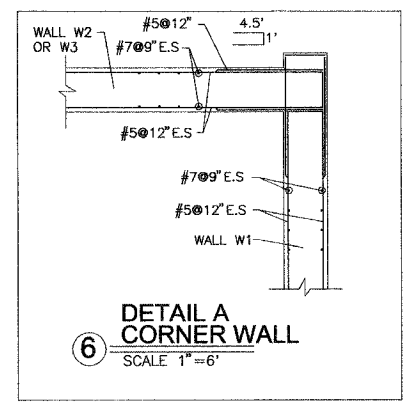
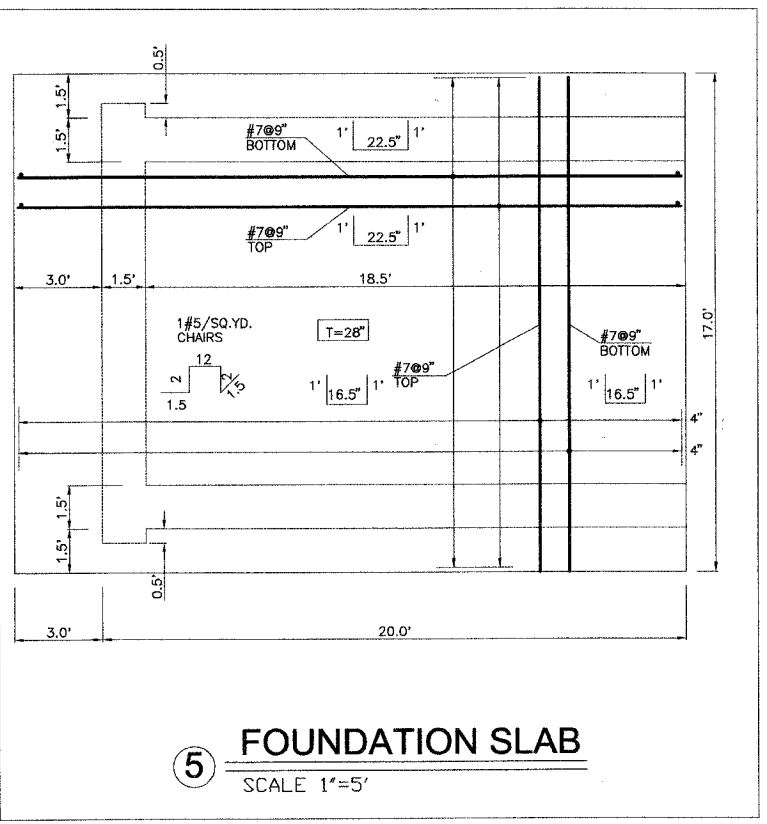
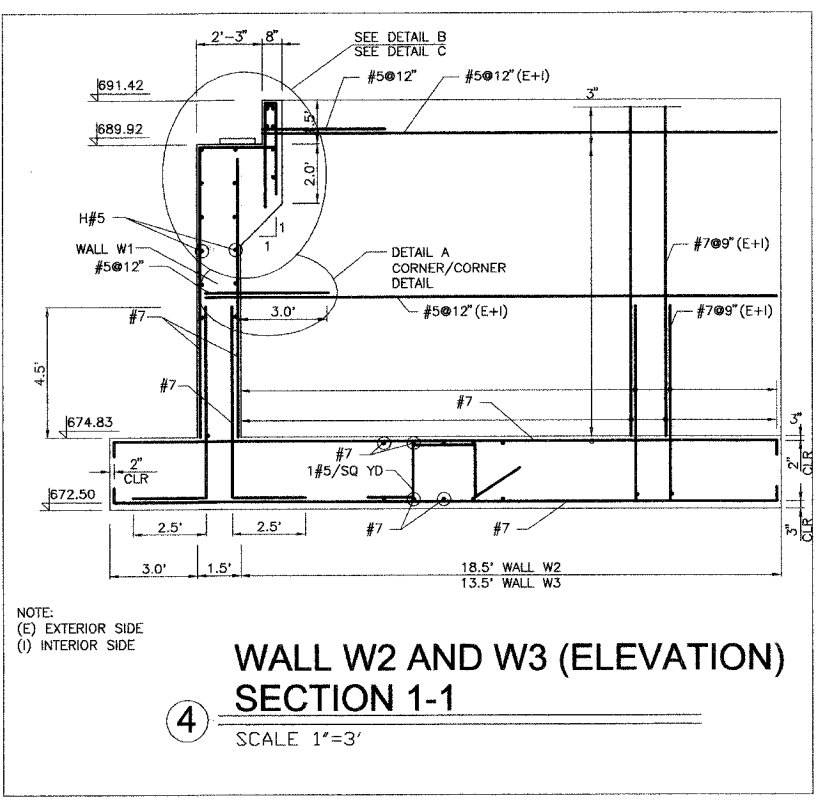
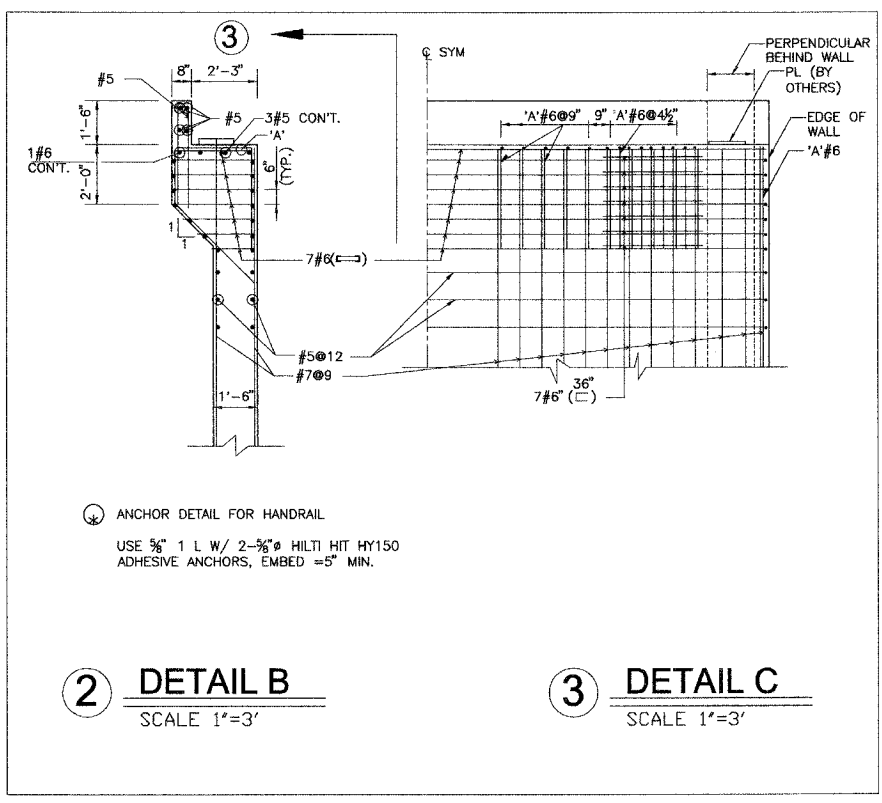
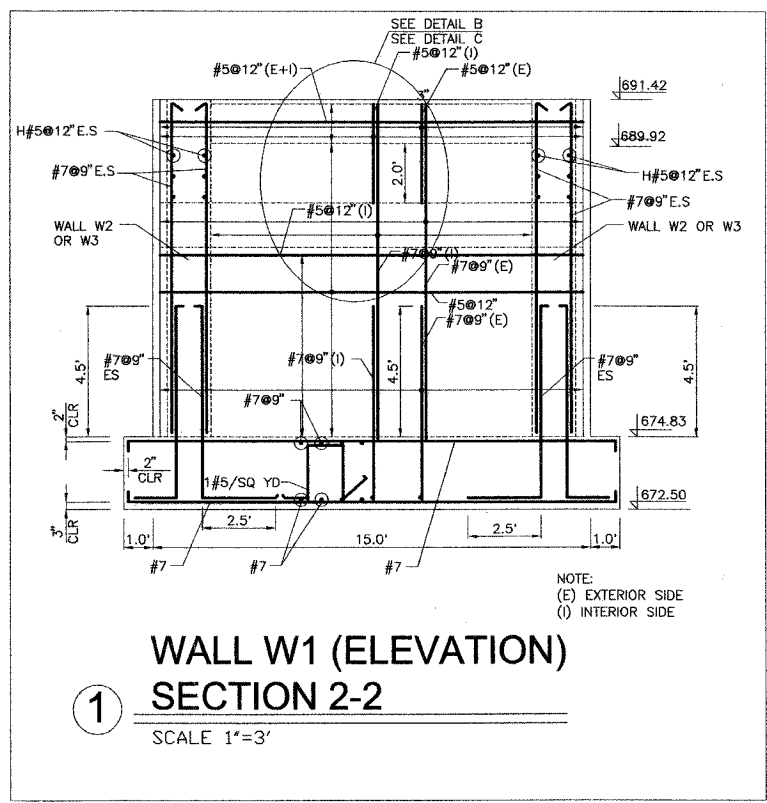

**TERRA**  
ENGINEERING LTD.  
505 N. LASALLE SUITE 250  
CHICAGO, IL 60610  
(312)467-0123

STATE OF ILLINOIS  
JIMMY L. BROWN  
REGISTERED STRUCTURAL ENGINEER  
081-004536  
Jimmy L. Brown  
Exp. 11/27/08

REVISIONS		ILLINOIS DEPARTMENT OF TRANSPORTATION
NAME	DATE	
		PRESERVATION BIKE PATH BRIDGE DETAILS (3)

SCALE: HORIZ.: AS SHOWN  
DATE: MAY 04, 2007  
DRAWN BY: CC  
CHECKED BY: SC