

TYPICAL #13

STA 18+21.66 'D' TO STA 37+35.58 'D'

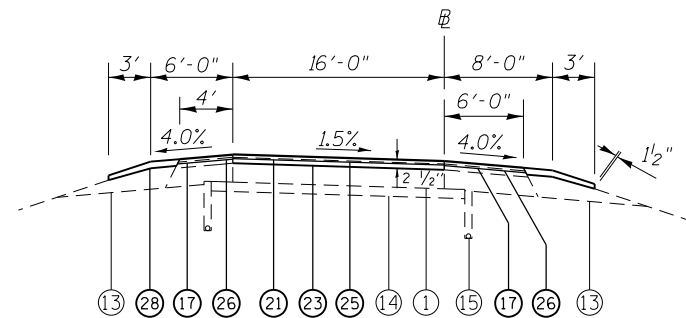

TYPICAL #14

BUSINESS 55 INTERCHANGE

RAMP A
STA 1+25.30 TO STA 27+59.81
RAMP B
STA 6+16.65 TO STA 30+77.69
RAMP C
STA 1+25.16 TO STA 14+31.87
RAMP D
STA 6+48.91 TO STA 22+00.00

NOTES:

1. MATCH EXISTING SUPERELEVATION SLOPES ON RAMPS.
2. LOW SIDE SHOULD BE 4.0% WHEN SE OF PAVEMENT IS BETWEEN 0.0% AND 4.0%. WHEN PAVEMENT IS GREATER THAN 4.0%, SHOULDER SLOPE SHALL MATCH SE. HIGH SIDE SHOULDER SHALL BE SLOPED AT 4.0% WHEN PAVEMENT IS BETWEEN 0.0% AND 4.0%. WHEN PAVEMENT IS GREATER THAN 4.0%, SHOULDER SHALL BE SLOPED SO THE ALGEBRAIC DIFFERENCE DOES NOT EXCEED 8.0%.
3. CONTINUOUS RUMBLE STRIPS, AS DETAILED ON STANDARD 642001, SHALL BE CONSTRUCTED ON ALL MAINLINE SHOULDERS EXCEPT WHERE NOTED ON STANDARD AND MEDIAN CROSS OVER DETAIL.

LEGEND

- | | |
|---|--|
| ① EX PCC CONC PAVEMENT - 8" | ①⑦ PR HOT MIX ASPHALT SURFACE REMOVAL, 3/4" |
| ② EX CRC PAVEMENT - 8" | ①⑧ PR HOT MIX ASPHALT SURFACE REMOVAL, 1 1/2" |
| ③ EX CRC PAVEMENT - 9" | ①⑨ PR HOT MIX ASPHALT SURFACE REMOVAL, 2" |
| ④ EX CRC PAVEMENT - 11" | ①⑩ PR HOT MIX ASPHALT SURFACE REMOVAL, 2 1/2" |
| ⑤ EX HOT MIX ASPHALT | ①⑪ PR HOT MIX ASPHALT SURFACE REMOVAL, 3 1/4" |
| ⑥ EX SUBBASE GRANULAR MATERIAL, TY B - 12" | ①⑫ PR HOT MIX ASPHALT SURFACE REMOVAL, 4 3/4" |
| ⑦ EX HOT MIX ASPHALT PAVEMENT - 3 1/4" | ①⑬ PR POLY HOT MIX ASPHALT BINDER COURSE, IL-19.0, FG, N90, (2 1/4") |
| ⑧ EX HOT MIX ASPHALT PAVEMENT - 2 1/2" | ①⑭ PR POLY HOT MIX ASPHALT BINDER COURSE, IL-19.0, FG, N90, (3 1/4") |
| ⑨ EX HOT MIX ASPHALT SHOULDER, VARIABLE DEPTH | ①⑮ PR POLY HOT MIX ASPHALT SURFACE COURSE, MIX "E", N90, (1 1/2") |
| ⑩ EX HOT MIX ASPHALT SHOULDER - 8" | ①⑯ PR HOT MIX ASPHALT SHOULDERS (MIX "C", N50), (2") |
| ⑪ EX HOT MIX ASPHALT SHOULDER - 9" | ①⑰ PR HOT MIX ASPHALT SHOULDERS, 8" |
| ⑫ EX HOT MIX ASPHALT SHOULDER - 12 1/4" | ①⑱ PR AGGREGATE WEDGE SHOULDER, TYPE B |
| ⑬ EX AGGREGATE SHOULDER | ①⑲ PR PIPE UNDERDRAINS, 4" |
| ⑭ EX STABILIZED SUBBASE - 4" | ①⑳ PR PIPE UNDERDRAINS, 4" (MODIFIED) |
| ⑮ EX PIPE UNDERDRAINS | |
| ⑯ EX PAVEMENT (BURIED) | |

FILE NAME =	USER NAME = sparksgw	DESIGNED -	REVISED -	STATE OF ILLINOIS DEPARTMENT OF TRANSPORTATION	F.A.I. ROUTE 55 TYPICAL SECTIONS	F.A.I. RTE.	SECTION	COUNTY	TOTAL SHEETS	SHEET NO.	
ci:\pwork\pwork\sparksgw\0215133\0672041-sht-typical.dgn	041-sht-typical.dgn	DRAWN -	REVISED -					LOGAN	108	31	
Default	PLOT SCALE = 100.0000' / 1"	CHECKED -	REVISED -			SCALE:	SHEET 7 OF SHEETS	STA.	TO STA.	ILLINOIS FED. AID PROJECT	CONTRACT NO. 72D41
	PLOT DATE = Jul-14-2014 03:37:03PM	DATE -	REVISED -								