

REFERENCE PROJECT	FIRST AVENUE	DESIGNED	MSK	DATE	DATE	DATE	DATE	DATE	DATE
CHECKED	JWW	DATE	DATE	DATE	DATE	DATE	DATE	DATE	DATE
APPROVED		DATE		DATE		DATE		DATE	

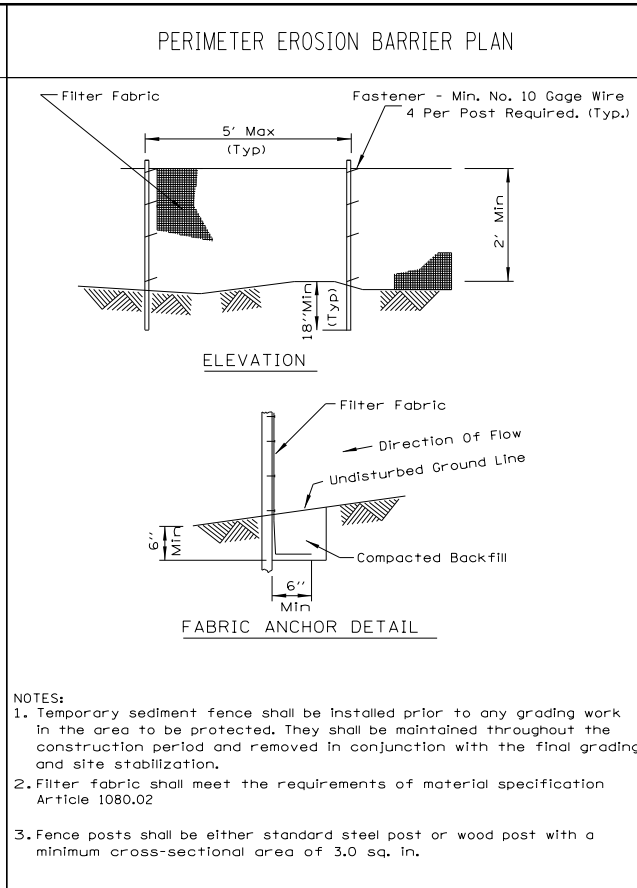

REFERENCE PROJECT	FIRST AVENUE	DESIGNED	MSK	DATE	DATE	DATE	DATE	DATE	DATE
CHECKED	JWW	DATE	DATE	DATE	DATE	DATE	DATE	DATE	DATE
APPROVED		DATE		DATE		DATE		DATE	

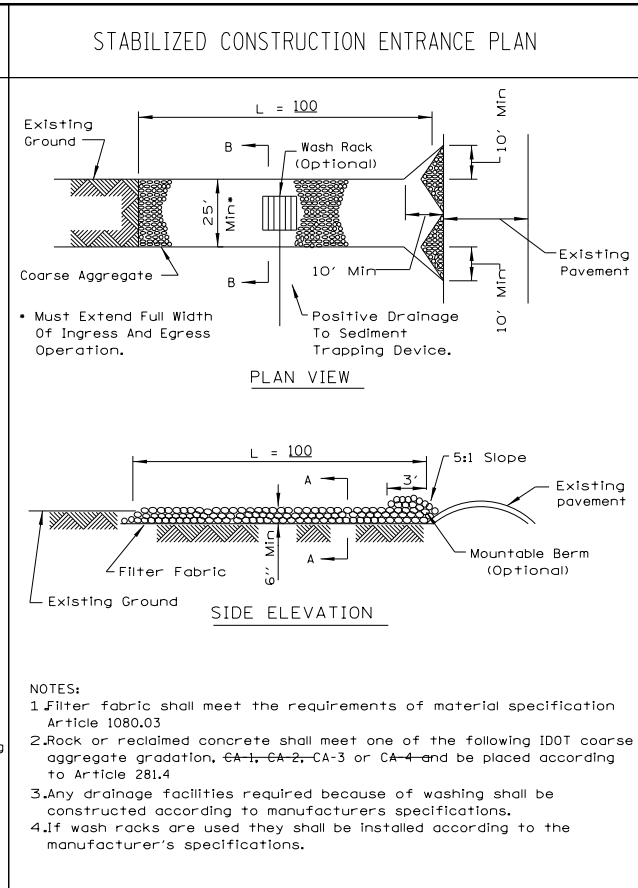

REFERENCE PROJECT	FIRST AVENUE	DESIGNED	MSK	DATE	DATE	DATE	DATE	DATE	DATE
CHECKED	JWW	DATE	DATE	DATE	DATE	DATE	DATE	DATE	DATE
APPROVED		DATE		DATE		DATE		DATE	

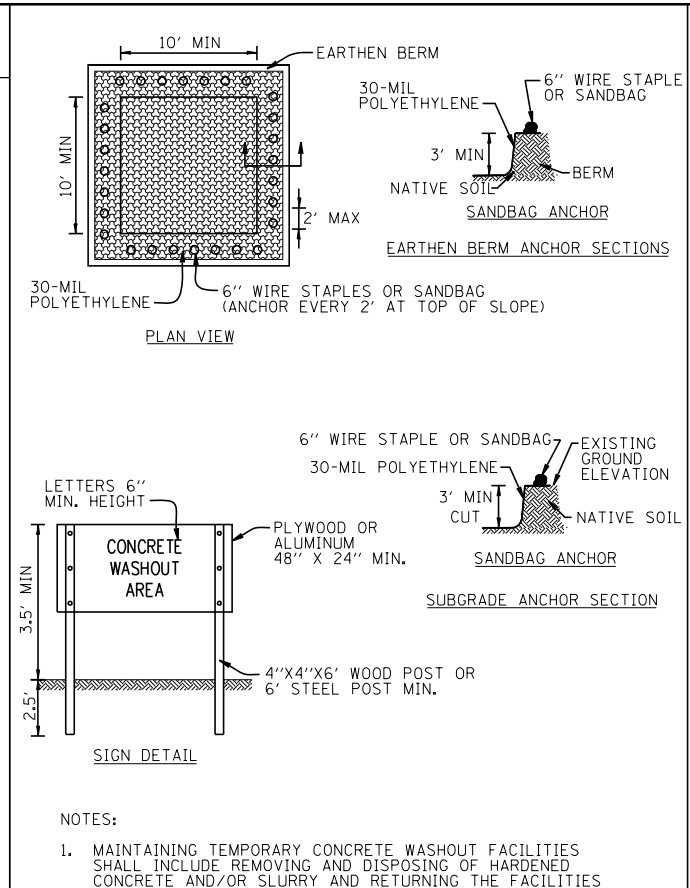

REFERENCE PROJECT	FIRST AVENUE	DESIGNED	MSK	DATE	DATE	DATE	DATE	DATE	DATE
CHECKED	JWW	DATE	DATE	DATE	DATE	DATE	DATE	DATE	DATE
APPROVED		DATE		DATE		DATE		DATE	

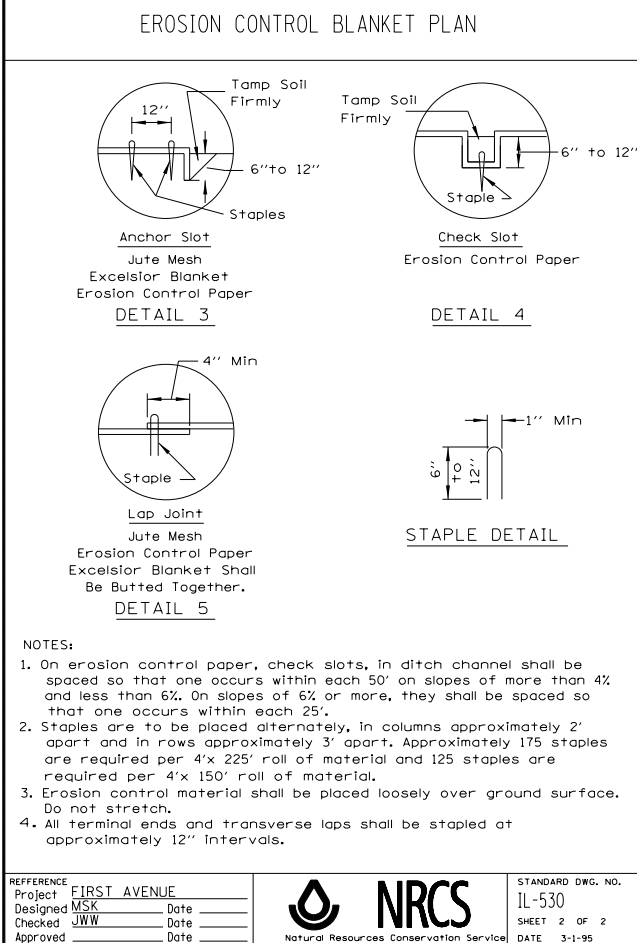

REFERENCE PROJECT	FIRST AVENUE	DESIGNED	MSK	DATE	DATE	DATE	DATE	DATE	DATE
CHECKED	JWW	DATE	DATE	DATE	DATE	DATE	DATE	DATE	DATE
APPROVED		DATE		DATE		DATE		DATE	

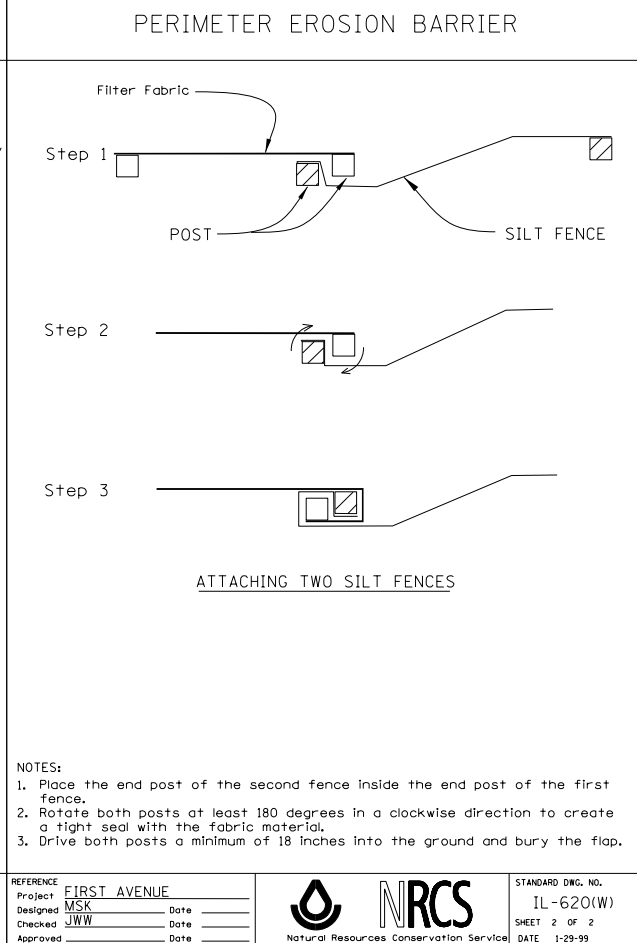

REFERENCE PROJECT	FIRST AVENUE	DESIGNED	MSK	DATE	DATE	DATE	DATE	DATE	DATE
CHECKED	JWW	DATE	DATE	DATE	DATE	DATE	DATE	DATE	DATE
APPROVED		DATE		DATE		DATE		DATE	

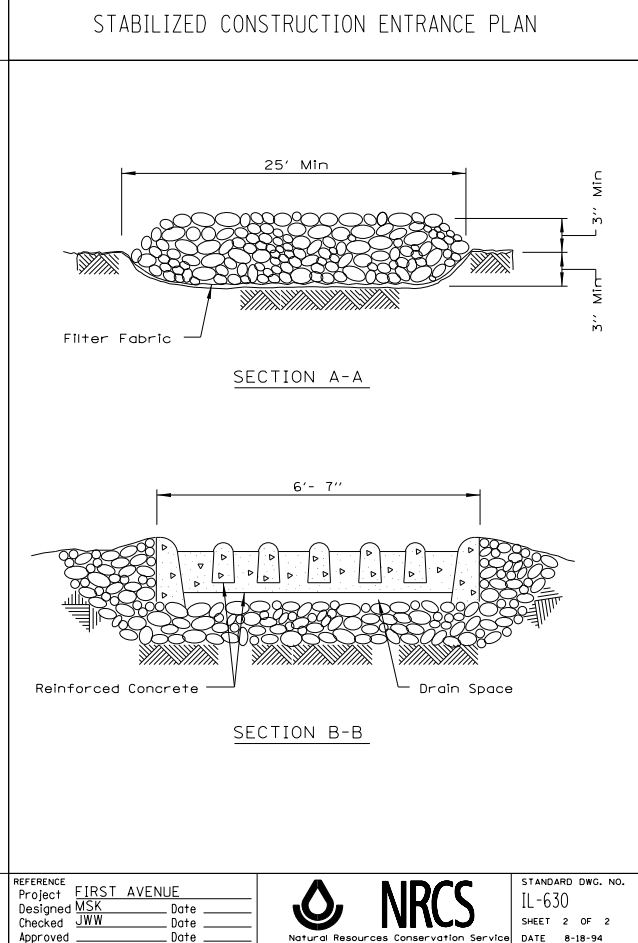

REFERENCE PROJECT	FIRST AVENUE	DESIGNED	MSK	DATE	DATE	DATE	DATE	DATE	DATE
CHECKED	JWW	DATE	DATE	DATE	DATE	DATE	DATE	DATE	DATE
APPROVED		DATE		DATE		DATE		DATE	

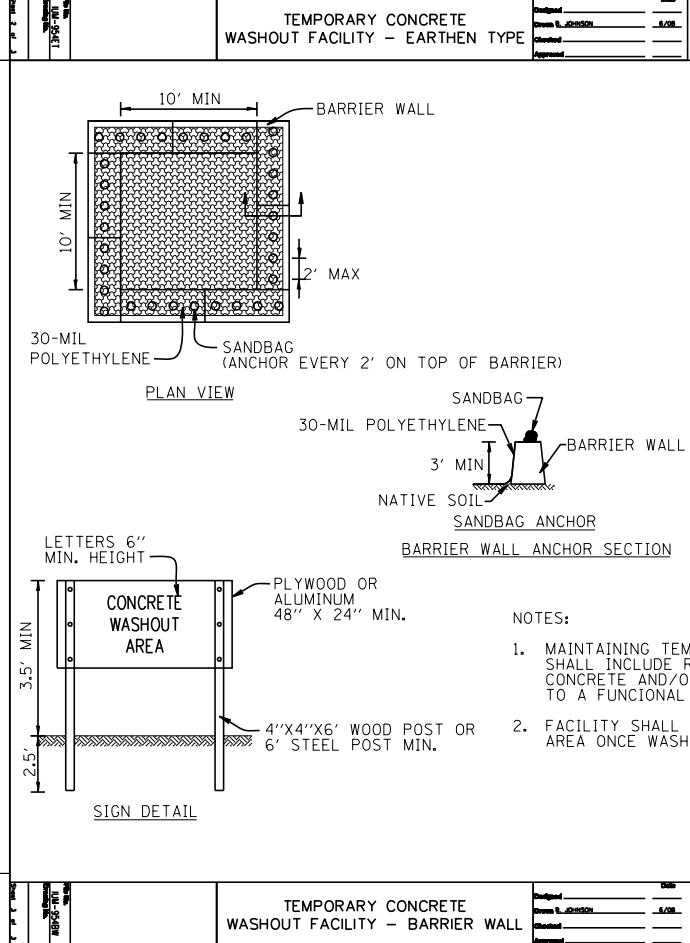

REFERENCE PROJECT	FIRST AVENUE	DESIGNED	MSK	DATE	DATE	DATE	DATE	DATE	DATE
CHECKED	JWW	DATE	DATE	DATE	DATE	DATE	DATE	DATE	DATE
APPROVED		DATE		DATE		DATE		DATE	