

SERVICE POLE

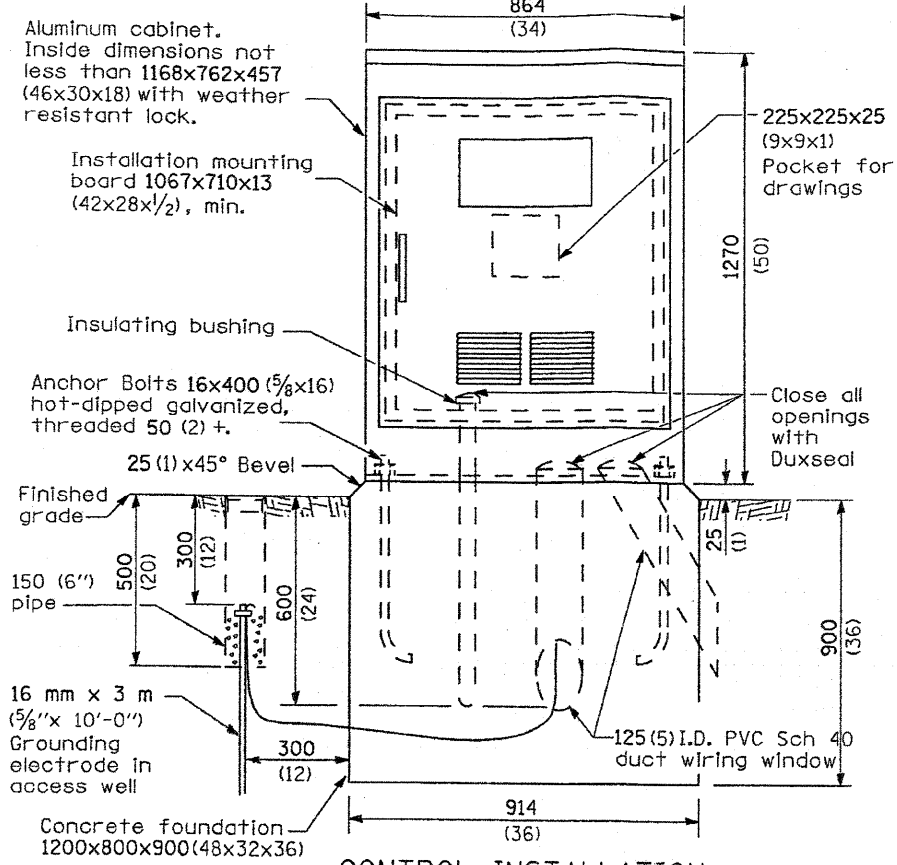

CONTROL INSTALLATION (FRONT VIEW)

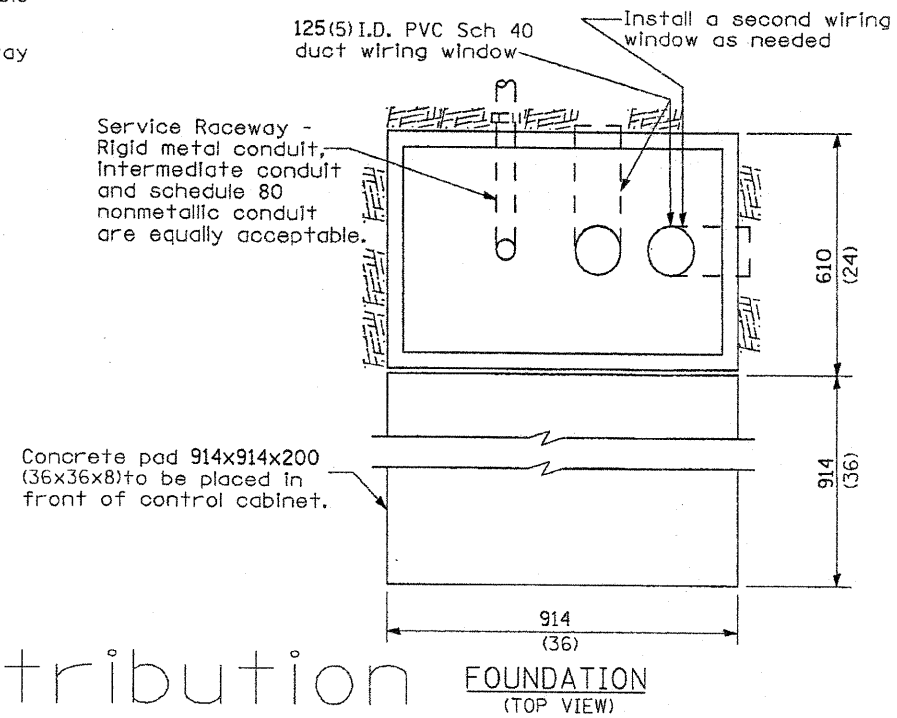

FOUNDATION (TOP VIEW)

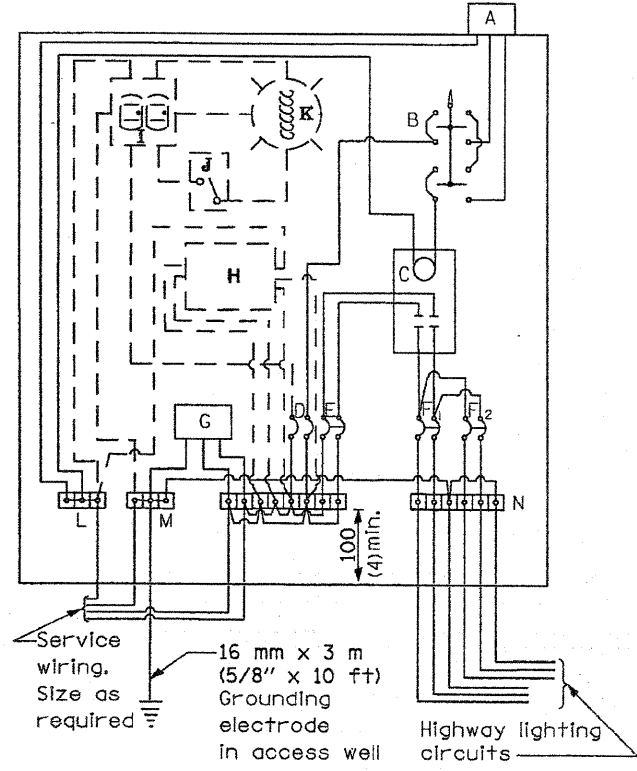

CONTROL SCHEMATIC

MATERIALS

- A Photocell w/ integral surge arrester (remote mount in urban areas)
 - B 3 position selector switch HAND-OFF-AUTO
 - C 100 amp* electrically held contactor, 120V operating coil
 - D 15 amp, 1 pole, circuit breaker
 - E 100 amp*, 2 pole, main circuit breaker
 - F 20 amp*, 2 pole, branch circuit breaker (typ). 2 spare c.b. required but not shown
 - G Surge arrester
 - H Transformer (see notes), 1 KVA*, 240/480V primary, 120/240V sec, single phase
 - I GFCI duplex receptacle
 - J Single pole, single throw switch
 - K Shielded security fixture with 100W lamp
 - L Neutral bar
 - M Equipment ground bar
 - N Terminal block (typ)
- (* = Size larger as needed)

GENERAL NOTES

Locate service pole and control installation adjacent to R.O.W. line with a minimum distance of 9 m (30') from the edge of pavement. Locate in close proximity to the utility transformer so the service drop does not exceed 46 m (150ft) and the total distance of overhead and underground cable (utility transformer to lighting controller) does not exceed 76 m (250ft). Exact location shall be established by the Engineer.

Wiring shall be panel board fashion. All bends shall be right angles. All runs shall vertical or parallel to panel board. Wires shall be grouped or laced.

All control installation components shall be U.L. listed.

Add receptacle, light, and switch in control cabinet, when specified.

For 480 V service, a step down transformer (dashed lines) is required.

Raceways shall terminate 75 (3) above top of concrete foundation.

Label equipment ground buss and neutral buss.

240 V. SERVICE

480 V. SERVICE

DATE	REVISIONS
	Corrected 1/19/06
4/14/09	Surge Arrester Wiring

**CONTROL INSTALLATION
Base Mount Cabinet**

DRAFT

LGT005.DGN

Contract 76047

33 of 93

DRAFT COPY
not for distribution