

TAPER AT SN 050-0189

*STA. 54+77.5
STA. 55+46.5

EXISTING 1 1/2" HMA ON DECK

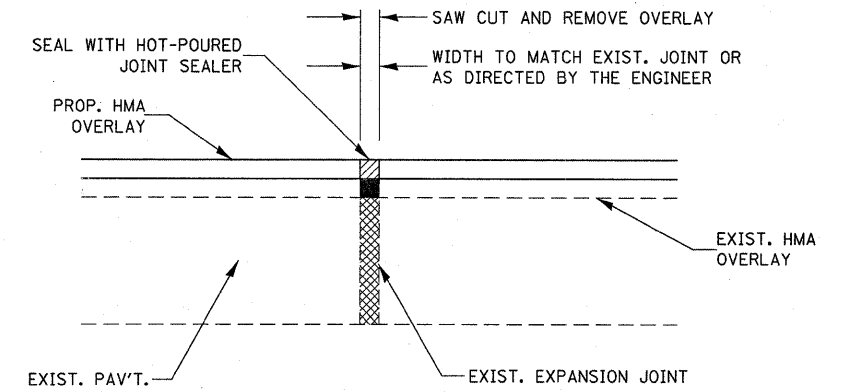

EXPANSION JOINT REHABILITATION DETAIL

GENERAL NOTES:

1. THE NEW HMA OVERLAY SHALL BE SAWED, REMOVED AND THE JOINT AREA CLEANED. PRIOR TO PLACING THE HOT-POURED JOINT SEALER, THE JOINT SHALL BE BLOWN OUT WITH COMPRESSED AIR.
2. THIS WORK WILL BE PAID FOR AT THE CONTRACT UNIT PRICE PER FOOT FOR EXPANSION JOINT REHABILITATION.

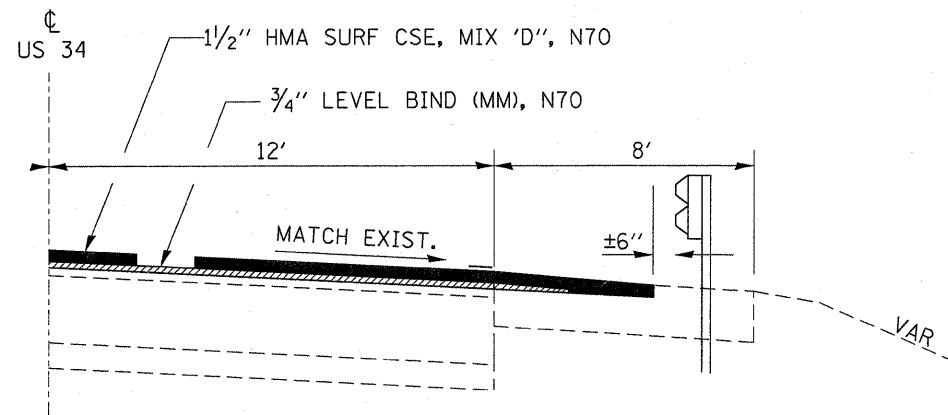

MILLING AT GUARDRAIL

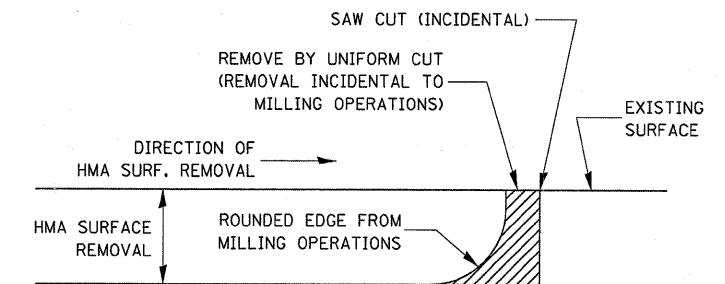

NOTE:

WHEN MILLING OPERATIONS PRODUCE A ROUNDED EDGE, THEN A SAW CUT SHALL BE USED TO MANUFACTURE A PERPENDICULAR EDGE AS SHOWN IN THE DETAIL. THE ENGINEER SHALL BE THE SOLE JUDGE CONCERNING THE USE OF THIS DETAIL

HMA DETAIL AT BUTT JOINTS

FILE NAME =	USER NAME = duncanbd	DESIGNED -	REVISED -	STATE OF ILLINOIS DEPARTMENT OF TRANSPORTATION	DETAILS			F.A.P. RTE.	SECTION	COUNTY	TOTAL SHEETS	SHEET NO.
cd\pw_work\PWIDOT\DUNCANBD\0135021\0365974-shr-details.DGN		DRAWN -	REVISED -		587	(20)RS-5	LASALLE	13	13			
PLOT SCALE = 50.0000' / IN.		CHECKED -	REVISED -		CONTRACT NO. 66974							
PLOT DATE = Apr 09, 2009 - 11:44:30 AM		DATE -	REVISED -		ILLINOIS FED. AID PROJECT							
				SCALE:	SHEET NO.	OF	SHEETS	STA.	TO	STA.		