

MILLED TEMPORARY RAMP
(FOR BUTT JOINT AND HMA TAPER SEE DETAIL BELOW)

OPTION 1

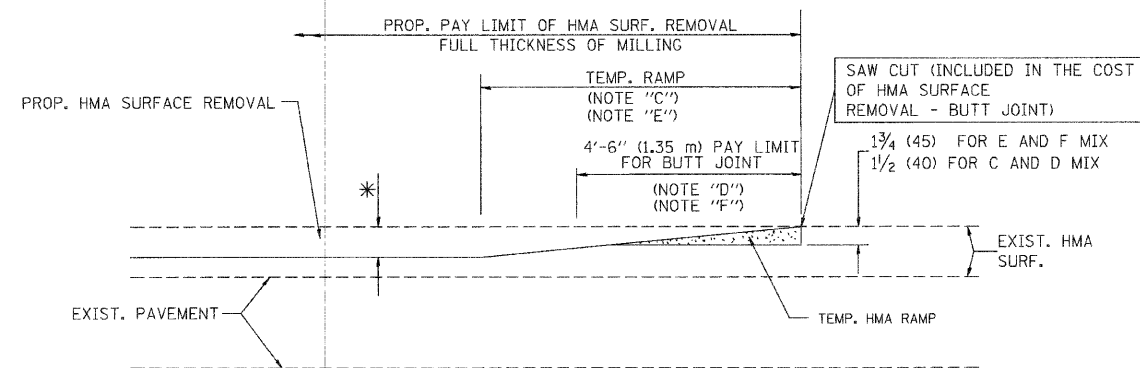

HMA CONSTRUCTED TEMPORARY RAMP
(FOR BUTT JOINT AND HMA TAPER SEE DETAIL BELOW)

OPTION 2

TYPICAL TEMPORARY RAMP

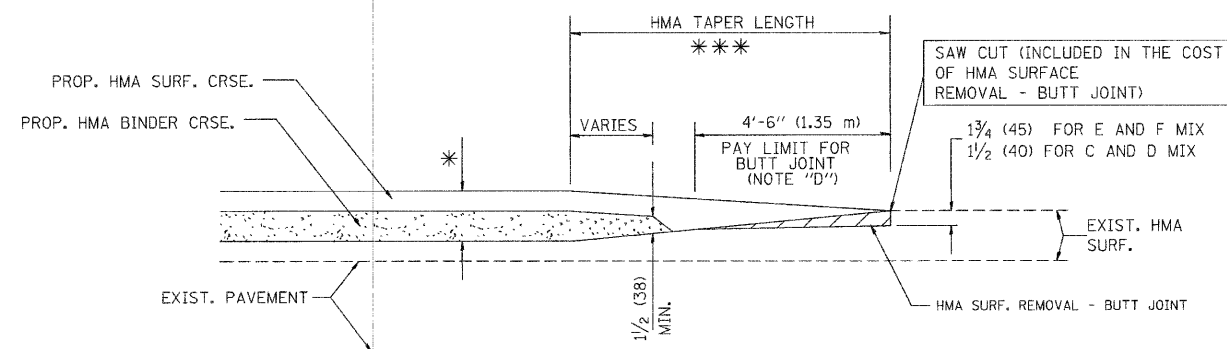

BUTT JOINT AND HMA TAPER
TYPICAL BUTT JOINT AND HMA TAPER
FOR MILLING AND RESURFACING

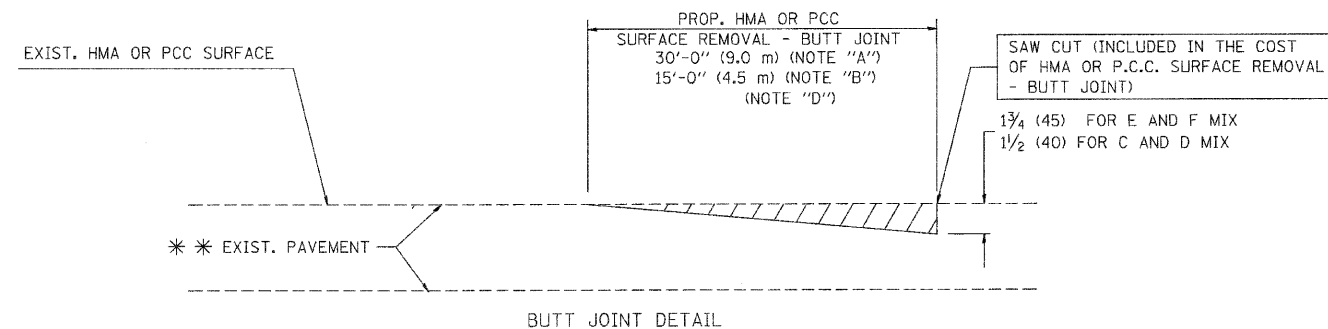

BUTT JOINT DETAIL

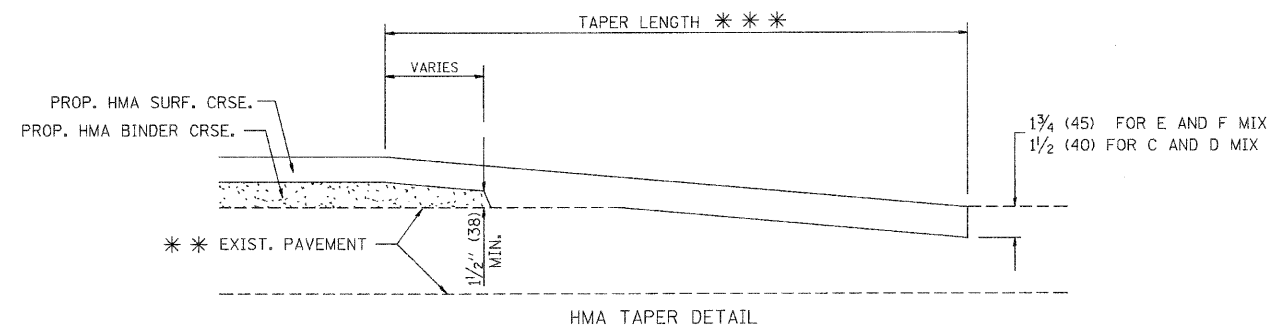

HMA TAPER DETAIL

TYPICAL BUTT JOINT AND HMA TAPER
FOR RESURFACING ONLY

*** PC CONCRETE, HMA OR HMA RESURFACED PAVEMENT.

NOTES

- A: MAINLINE ROADWAYS AND MAJOR SIDE ROADS.
 - B: MINOR SIDE ROADS.
 - C: THE TEMP. RAMP SHALL BE CONSTRUCTED IMMEDIATELY UPON REMOVAL OF THE EXISTING HMA SURFACE.
 - D: THE BUTT JOINT SHALL BE CONSTRUCTED IMMEDIATELY PRIOR TO PLACING THE PROPOSED HMA COURSES.
 - E: TAPER THE TEMP. RAMP AT A RATE OF 3'-0" (900 mm) PER 1 INCH (25 mm) OF MILLING THICKNESS.
 - F: INSTALLATION AND REMOVAL OF THE 4'-6" (1.35 m) TEMP. RAMP IS INCLUDED IN COST OF HMA SURFACE REMOVAL - BUTT JOINT
 - G: SEE ARTICLE 406.08 AND 406.14 OF THE STANDARD SPECIFICATIONS FOR "HMA AND/OR PCC SURFACE REMOVAL, BUTT JOINT".
- * SEE TYPICAL SECTIONS FOR MILLING THICKNESS.
- *** 20'-0" (6.1 m) PER 1 (25) RESURFACING (NOTE "A")
10'-0" (3.0 m) PER 1 (25) RESURFACING (NOTE "B")

BASIS OF PAYMENT:

THE BUTT JOINT WILL BE PAID FOR AT THE CONTRACT UNIT PRICE PER SQUARE YARD (SQUARE METER) FOR "HOT-MIX ASPHALT SURFACE REMOVAL - BUTT JOINT" OR FOR "PORTLAND CEMENT CONCRETE SURFACE REMOVAL - BUTT JOINT".

ALL DIMENSIONS ARE IN INCHES (MILLIMETERS) UNLESS OTHERWISE SHOWN.

| | | | |
|---|------------------------------|------------------------|------------------------------|
| FILE NAME = 06195_01-DTLS-01-BD32 - BD-32 | USER NAME = gegltenobt | DESIGNED -- M. DE YONG | REVISED -- R. SHAH 10-25-94 |
| | | CHECKED -- | REVISED -- A. ABBAS 03-21-97 |
| | PLOT SCALE = 5/8" = 1" / IN. | DRAWN -- | REVISED -- M. GOMEZ 04-06-01 |
| | PLOT DATE = 1/4/2008 | CHECKED -- 06-13-90 | REVISED -- R. BORO 01-01-07 |

STATE OF ILLINOIS
DEPARTMENT OF TRANSPORTATION

| | | | | | |
|-----------------------|--|---------------------------|-------------|--------------------------------|--------------|
| SCALE: | | SHEET NO. 12 OF 18 SHEETS | | STA. TO STA. | |
| F.A.I. RTE. 94 | | SECTION 10-00088-00-RS | COUNTY COOK | TOTAL SHEETS 18 | SHEET NO. 12 |
| BD400-05 | | BD32 | | CONTRACT NO. 63495 | |
| FED. ROAD DIST. NO. 1 | | ILLINOIS | | FED. AID PROJECT ARA-9003(668) | |