

STATE OF ILLINOIS  
DEPARTMENT OF TRANSPORTATION

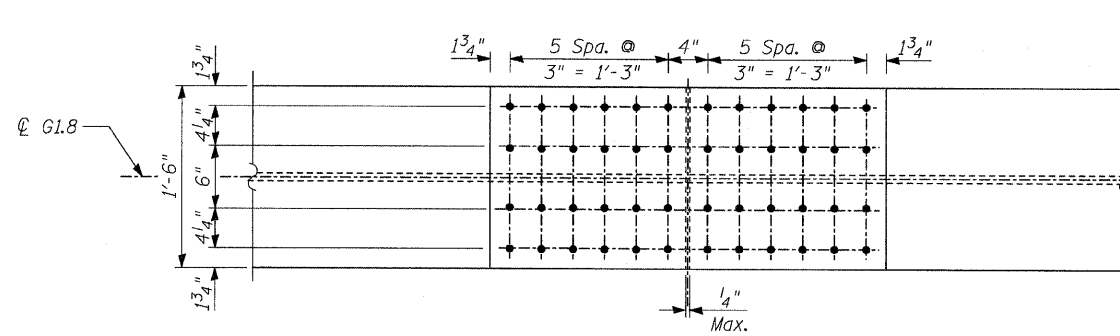

PLAN - TOP & BOTTOM FLANGE  
FIELD SPLICE FS-1.1

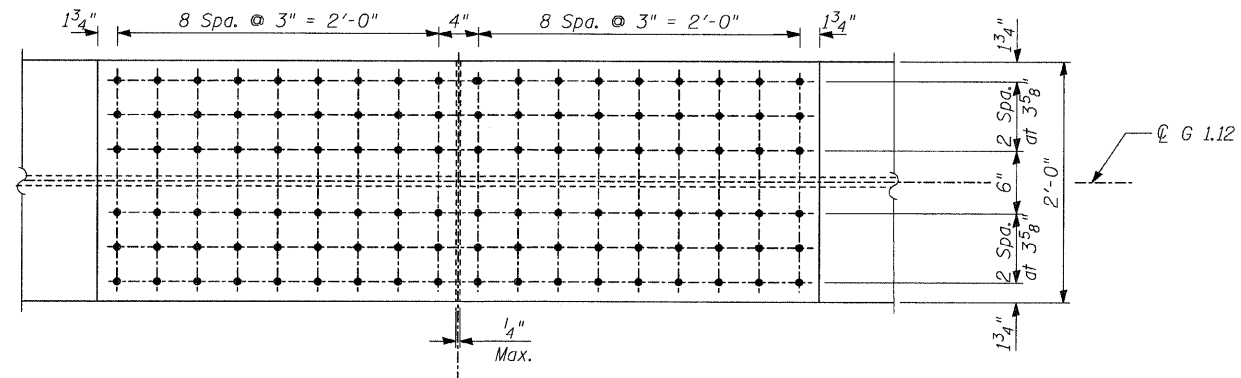

PLAN - TOP & BOTTOM FLANGE  
FIELD SPLICE FS-1.2 & 1.3

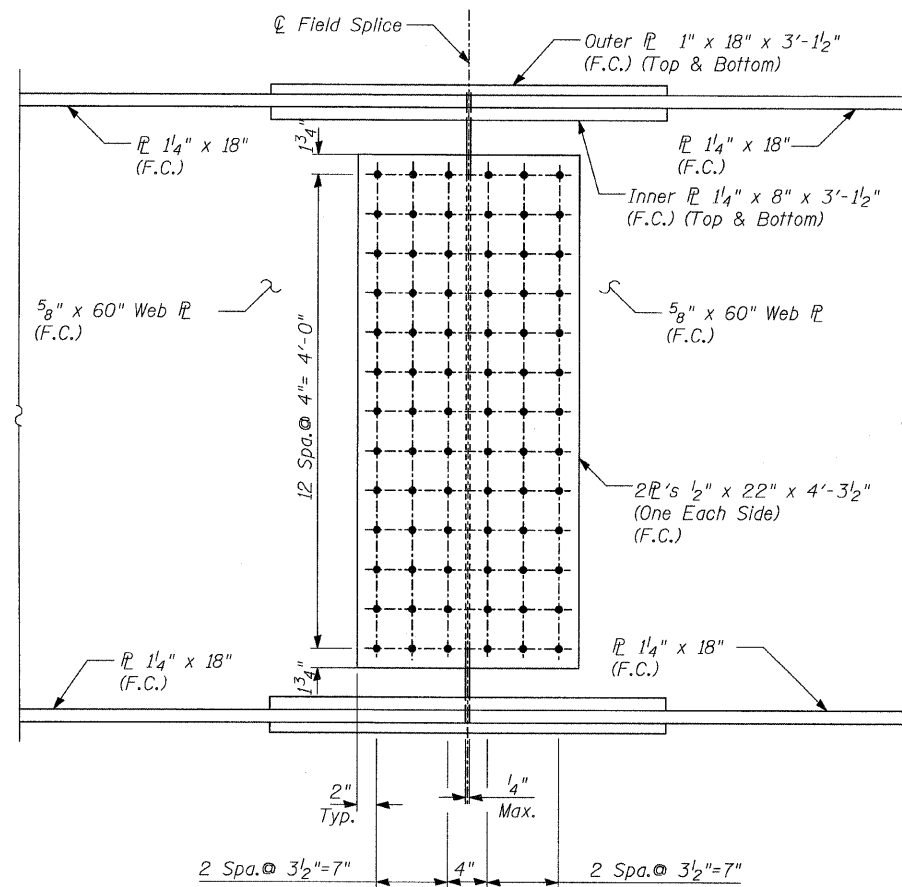

ELEVATION

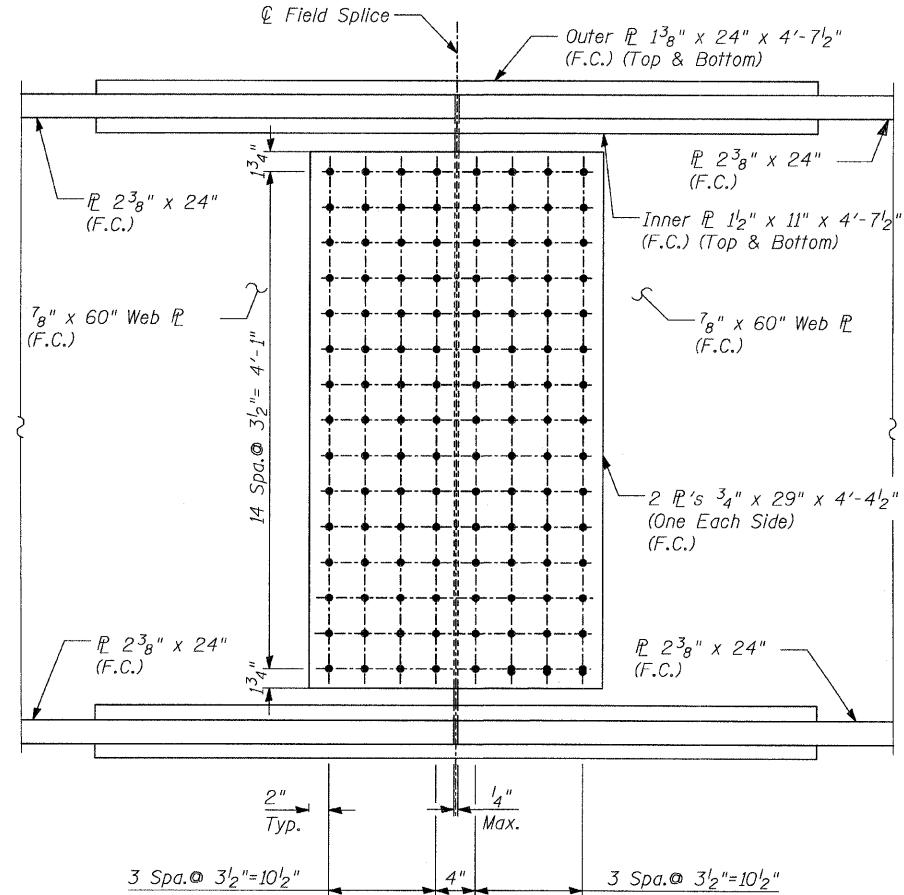

ELEVATION

NOTES:

- All steel shall be AASHTO M270 Grade 50.
- F.C. denotes Fracture Critical Material, AASHTO Zone 2.

FIELD SPLICES  
RAMP 1  
STRUCTURE NO. 016-0724

TYLIN INTERNATIONAL

DESIGNED - EKH, JMA	REVISIONS	
CHECKED - AMD,	NAME	DATE
DRAWN - EKH, JMA		
CHECKED - AMD,		
DATE - 08/02/10		

SHEET NO. 73 137 SHEETS	F.A.I. RTE. 55	SECTION 0711.2R & 1011.1BR	COUNTY COOK	TOTAL SHEETS 200	SHEET NO. 103
	FED. ROAD DIST. NO. 1 ILLINOIS FED. AID PROJECT			CONTRACT NO. 60L39	